

MID COUNTY PARKWAY TRAFFIC TECHNICAL REPORT

08-RIV-MCP PM 0.0/16.3
08-RIV-215 PM 28.0/34.3
EA 08-250-0F3200
(PN 0800000125)

Prepared for:

Riverside County Transportation Commission

Prepared by:



VRPA Technologies, Inc.
9520 Padgett Street, Suite 213
San Diego, CA 92126

In association with:
Jacobs

February 3, 2012

1.	INTRODUCTION	1-1
	Project Information.....	1-1
2.	METHODOLOGY	2-1
	Opening Year of Project.....	2-1
	Project Design Concept.....	2-1
	Project Alternatives.....	2-1
	Interchanges.....	2-2
	Traffic Analysis Scenarios.....	2-2
	Roadway Network.....	2-3
	Study Area.....	2-3
	Capacity Analysis.....	2-3
	Truck Percentages.....	2-4
	Rounding of Traffic Forecasts.....	2-4
	Opening Year (2020) Phased Project.....	2-4
	2030 Project Phasing Analysis.....	2-6
3.	EXISTING CONDITIONS	3-1
	Lane Geometry.....	3-1
	Average Daily Traffic Conditions.....	3-1
	Peak Hour Traffic Conditions.....	3-1
4.	FUTURE TRAFFIC FORECASTS	4-1
5.	DETERMINATION OF STUDY AREA	5-1
	Methodology.....	5-1
	Traffic Analysis.....	5-2
	Study Area.....	5-3
6.	OPENING YEAR (2020) CONDITIONS	6-1
	2020 No Build Traffic Conditions.....	6-1
	2020 Build Traffic Conditions.....	6-1
7.	HORIZON YEAR (2040) CONDITIONS	7-1
	2040 No Build Traffic Conditions.....	7-1
	2040 Alternative 4 Traffic Conditions.....	7-1
	2040 Alternative 5 Traffic Conditions.....	7-1
	2040 Alternative 9 Traffic Conditions.....	7-1
8.	TRAFFIC IMPACTS AND MITIGATION	8-1
	Analysis of Impacts – 2020 Opening Year Conditions.....	8-1
	Analysis of Impacts – 2040 Horizon Year Conditions.....	8-1
	Mitigation.....	8-2

TABLE OF CONTENTS (CONT.)

Page No.

9.	PROJECT PHASING	9-1
	Project Phasing Methodology.....	9-1
	2030 Alternative 4 Traffic Conditions.....	9-2
	2030 Alternative 5 Traffic Conditions.....	9-2
	2030 Alternative 9 Traffic Conditions.....	9-2
10.	SUMMARY OF RESULTS AND CONCLUSIONS	10-1
	Project Benefits.....	10-1
	Project Traffic Impacts.....	10-2
	Level of Service.....	10-2
	Existing (2010) Conditions.....	10-3
	Opening Year (2020) Conditions.....	10-4
	Horizon Year (2040) Conditions.....	10-7

APPENDIX A - SCAG 2008 RTP Projects within the MCP Study Area

APPENDIX B - Intersection Capacity Analysis (Bound Separately)

APPENDIX C - Freeway and Ramp Capacity Analysis (Bound Separately)

APPENDIX D - Mid County Parkway Travel Time Analysis

LIST OF FIGURES

Figure No.

- 1-1 Project Location

- 2-1 Alternative 4: Modified (Perris Drain)
- 2-2 Alternative 5: Modified (Rider)
- 2-3 Alternative 9: Modified (Placentia)
- 2-4 SR 79/MCP Interchange North Design Variation
- 2-5 2040 Roadway Network Assumptions
- 2-6 Roadway Segment Analysis Outside MCP Project Area
- 2-7 Opening Year (2020) Phased Project Proposed Improvements

- 3-1 Existing (2010) Freeway Mainline Lane Geometry - Interstate 15
- 3-2 Existing (2010) Freeway Mainline Lane Geometry - Interstate 215
- 3-3 Existing (2010) Intersection Lane Geometry
- 3-4 Existing (2010) ADT Freeway and Street Segments – MCP Area
- 3-5 Existing (2010) ADT Freeway and Street Segments – Outside MCP Area
- 3-6 Existing (2010) Freeway and Ramp Traffic - Interstate 15
- 3-7 Existing (2010) Freeway and Ramp Traffic - Interstate 215
- 3-8 Existing (2010) AM/PM Peak Hour Traffic Intersections

- 5-1 Horizon Year (2040) Average Daily Traffic – Extended Study Area – Alternative 4 Modified
- 5-2 Horizon Year (2040) Average Daily Traffic – Extended Study Area – Alternative 5 Modified
- 5-3 Horizon Year (2040) Average Daily Traffic – Extended Study Area – Alternative 9 Modified

- 6-1 Opening Year (2020) Freeway Mainline Lane Geometry Interstate 15 – No Build
- 6-2 Opening Year (2020) Freeway Mainline Lane Geometry Interstate 215 – No Build
- 6-3 Opening Year (2020) Intersection Lane Geometry – No Build
- 6-4 Opening Year (2020) ADT Freeway and Street Segments - MCP Area – No Build
- 6-5 Opening Year (2020) ADT Freeway and Street Segments - Outside MCP Area – No Build
- 6-6 Opening Year (2020) Freeway and Ramp Traffic Interstate 15 – No Build
- 6-7 Opening Year (2020) Freeway and Ramp Traffic Interstate 215 – No Build
- 6-8 Opening Year (2020) AM/PM Peak Hour Traffic Intersections – No Build
- 6-9 Opening Year (2020) Freeway Mainline Lane Geometry Mid County Parkway – Build
- 6-10 Opening Year (2020) Freeway Mainline Lane Geometry Interstate 15 – Build
- 6-11 Opening Year (2020) Freeway Mainline Lane Geometry Interstate 215 – Build
- 6-12 Opening Year (2020) Intersection Lane Geometry – Build
- 6-13 Opening Year (2020) ADT Freeway and Street Segments MCP Area – Build
- 6-14 Opening Year (2020) ADT Freeway and Street Segments Outside MCP Area – Build
- 6-15 Opening Year (2020) Freeway and Ramp Traffic Mid County Parkway – Build
- 6-16 Opening Year (2020) Freeway and Ramp Traffic Interstate 15 – Build
- 6-17 Opening Year (2020) Freeway and Ramp Traffic Interstate 215 – Build
- 6-18 Opening Year (2020) AM/PM Peak Hour Traffic Intersections – Build

LIST OF FIGURES (Continued)

Figure No.

- 7-1 Horizon Year (2040) ADT Freeway and Street Segments MCP Area – No Build
- 7-2 Horizon Year (2040) ADT Freeway and Street Segments Outside MCP Area – No Build
- 7-3 Horizon Year (2040) Freeway and Ramp Traffic Interstate 15 – No Build
- 7-4 Horizon Year (2040) Freeway and Ramp Traffic Interstate 215 – No Build
- 7-5 Horizon Year (2040) AM/PM Peak Hour Traffic Intersections – No Build
- 7-6 Horizon Year (2040) Freeway Mainline Lane Geometry Interstate 15 – No Build
- 7-7 Horizon Year (2040) Freeway Mainline Lane Geometry Interstate 215 – No Build
- 7-8 Horizon Year (2040) Intersection Lane Geometry – No Build/Existing Conditions
- 7-9 Horizon Year (2040) Intersection Lane Geometry – No Build/County General Plan
- 7-10 Horizon Year (2040) Freeway Mainline Lane Geometry Mid County Parkway – Alternative 4
- 7-11 Horizon Year (2040) Freeway Mainline Lane Geometry Interstate 15 – Alternative 4
- 7-12 Horizon Year (2040) Freeway Mainline Lane Geometry Interstate 215 – Alternative 4
- 7-13 Horizon Year (2040) MCP/I-215 Interchange Area Lane Geometry – Alternative 4
- 7-14 Horizon Year (2040) MCP/SR-79 Interchange Area Lane Geometry – Alternative 4
- 7-15 Horizon Year (2040) Intersection Lane Geometry – Alternative 4
- 7-16 Horizon Year (2040) ADT Freeway and Street Segments MCP Area – Alternative 4
- 7-17 Horizon Year (2040) ADT Freeway and Street Segments Outside MCP Area – Alternative 4
- 7-18 Horizon Year (2040) Freeway and Ramp Traffic Mid County Parkway – Alternative 4
- 7-19 Horizon Year (2040) Freeway and Ramp Traffic Interstate 15 – Alternative 4
- 7-20 Horizon Year (2040) Freeway and Ramp Traffic Interstate 215 – Alternative 4
- 7-21 Horizon Year (2040) MCP/I-215 Interchange Area Traffic – Alternative 4
- 7-22 Horizon Year (2040) MCP/SR-79 Interchange Area Traffic – Alternative 4
- 7-23 Horizon Year (2040) AM/PM Peak Hour Traffic Intersections – Alternative 4
- 7-24 Horizon Year (2040) Freeway Mainline Lane Geometry Mid County Parkway – Alternative 5
- 7-25 Horizon Year (2040) Freeway Mainline Lane Geometry Interstate 15 – Alternative 5
- 7-26 Horizon Year (2040) Freeway Mainline Lane Geometry Interstate 215 – Alternative 5
- 7-27 Horizon Year (2040) MCP/I-215 Interchange Area Lane Geometry – Alternative 5
- 7-28 Horizon Year (2040) MCP/SR-79 Interchange Area Lane Geometry – Alternative 5
- 7-29 Horizon Year (2040) Intersection Lane Geometry – Alternative 5
- 7-30 Horizon Year (2040) ADT Freeway and Street Segments MCP Area – Alternative 5
- 7-31 Horizon Year (2040) ADT Freeway and Street Segments Outside MCP Area – Alternative 5
- 7-32 Horizon Year (2040) Freeway and Ramp Traffic Mid County Parkway – Alternative 5
- 7-33 Horizon Year (2040) Freeway and Ramp Traffic Interstate 15 – Alternative 5
- 7-34 Horizon Year (2040) Freeway and Ramp Traffic Interstate 215 – Alternative 5
- 7-35 Horizon Year (2040) MCP/I-215 Interchange Area Traffic – Alternative 5
- 7-36 Horizon Year (2040) MCP/SR-79 Interchange Area Traffic – Alternative 5
- 7-37 Horizon Year (2040) AM/PM Peak Hour Traffic Intersections – Alternative 5
- 7-38 Horizon Year (2040) Freeway Mainline Lane Geometry Mid County Parkway – Alternative 9
- 7-39 Horizon Year (2040) Freeway Mainline Lane Geometry Interstate 15 – Alternative 9
- 7-40 Horizon Year (2040) Freeway Mainline Lane Geometry Interstate 215 – Alternative 9
- 7-41 Horizon Year (2040) MCP/I-215 Interchange Area Lane Geometry – Alternative 9
- 7-42 Horizon Year (2040) MCP/SR-79 Interchange Area Lane Geometry – Alternative 9
- 7-43 Horizon Year (2040) Intersection Lane Geometry – Alternative 9

LIST OF FIGURES (Continued)

Figure No.

- 7-44 Horizon Year (2040) ADT Freeway and Street Segments MCP Area – Alternative 9
- 7-45 Horizon Year (2040) ADT Freeway and Street Segments Outside MCP Area – Alternative 9
- 7-46 Horizon Year (2040) Freeway and Ramp Traffic Mid County Parkway – Alternative 9
- 7-47 Horizon Year (2040) Freeway and Ramp Traffic Interstate 15 – Alternative 9
- 7-48 Horizon Year (2040) Freeway and Ramp Traffic Interstate 215 – Alternative 9
- 7-49 Horizon Year (2040) MCP/I-215 Interchange Area Traffic – Alternative 9
- 7-50 Horizon Year (2040) MCP/SR-79 Interchange Area Traffic – Alternative 9
- 7-51 Horizon Year (2040) AM/PM Peak Hour Traffic Intersections – Alternative 9
- 7-52 Horizon Year (2040) MCP/SR-79 Interchange Area Lane Geometry – San Jacinto North Design Variation
- 7-53 Horizon Year (2040) Intersection Lane Geometry – San Jacinto North Design Variation
- 7-54 Horizon Year (2040) ADT – San Jacinto North Design Variation
- 7-55 Horizon Year (2040) MCP/SR-79 Interchange Area Traffic – San Jacinto North Design Variation
- 7-56 Horizon Year (2040) AM/PM Peak Hour Traffic – San Jacinto North Design Variation

- 9-1 Phase 1 – Opening Year (2020) Proposed Improvements
- 9-2 Phase 2 – Future Year (2030) Proposed Improvements – Alternative 4
- 9-3 Phase 2 – Future Year (2030) Proposed Improvements – Alternative 5
- 9-4 Phase 2 – Future Year (2030) Proposed Improvements – Alternative 9
- 9-5 Phase 3 – Horizon Year (2040) Proposed Improvements – Alternative 4
- 9-6 Phase 3 – Horizon Year (2040) Proposed Improvements – Alternative 5
- 9-7 Phase 3 – Horizon Year (2040) Proposed Improvements – Alternative 9
- 9-8 Future Year (2030) Average Daily Traffic – No Build
- 9-9 Future Year (2030) Average Daily Traffic – Alternative 4
- 9-10 Future Year (2030) Average Daily Traffic – Alternative 5
- 9-11 Future Year (2030) Average Daily Traffic – Alternative 9

- 10-1 Horizon Year (2040) Vehicle Travel Time
- 10-2 Horizon Year (2040) No Build ADT Compared to Build ADT
- 10-3 Horizon Year (2040) I-215 Freeway Segment Operations

LIST OF TABLES

Table No.

- 2-1 Proposed 2040 Regional Roadway Network Assumptions
- 2-2 Freeway and Ramp Capacity Analysis Assumptions
- 2-3 Intersection Capacity Analysis Assumptions
- 2-4 Proposed 2020 Regional Roadway Network Assumptions

- 3-1 Existing (2010) Freeway and Ramp Capacity Analysis - Interstate 15
- 3-2 Existing (2010) Freeway and Ramp Capacity Analysis - Interstate 215
- 3-3 Existing (2010) Intersection Capacity Analysis

- 6-1 Opening Year (2020) Freeway and Ramp Capacity Analysis Interstate 15 – No Build
- 6-2 Opening Year (2020) Freeway and Ramp Capacity Analysis Interstate 215 – No Build
- 6-3 Opening Year (2020) No Build Intersection Capacity Analysis
- 6-4 Opening Year (2020) Freeway and Ramp Capacity Analysis Interstate 15 – Build
- 6-5 Opening Year (2020) Freeway and Ramp Capacity Analysis Interstate 215 – Build
- 6-6 Opening Year (2020) Freeway and Ramp Capacity Analysis MCP – Build
- 6-7 Opening Year (2020) Intersection Capacity Analysis – Build

- 7-1 Horizon Year (2040) Freeway and Ramp Capacity Analysis Interstate 15 – No Build
- 7-2 Horizon Year (2040) Freeway and Ramp Capacity Analysis Interstate 215 – No Build
- 7-3 Horizon Year (2040) No Build/Existing Conditions Intersection Capacity Analysis
- 7-4 Horizon Year (2040) No Build/County General Plan Intersection Capacity Analysis
- 7-5 Horizon Year (2040) Freeway and Ramp Capacity Analysis Interstate 15 – Alternative 4
- 7-6 Horizon Year (2040) Freeway and Ramp Capacity Analysis Interstate 215 – Alternative 4
- 7-7 Horizon Year (2040) Freeway and Ramp Capacity Analysis MCP – Alternative 4
- 7-8 Horizon Year (2040) Intersection Capacity Analysis – Alternative 4
- 7-9 Horizon Year (2040) Freeway and Ramp Capacity Analysis Interstate 15 – Alternative 5
- 7-10 Horizon Year (2040) Freeway and Ramp Capacity Analysis Interstate 215 – Alternative 5
- 7-11 Horizon Year (2040) Freeway and Ramp Capacity Analysis MCP – Alternative 5
- 7-12 Horizon Year (2040) Intersection Capacity Analysis – Alternative 5
- 7-13 Horizon Year (2040) Freeway and Ramp Capacity Analysis Interstate 15 – Alternative 9
- 7-14 Horizon Year (2040) Freeway and Ramp Capacity Analysis Interstate 215 – Alternative 9
- 7-15 Horizon Year (2040) Freeway and Ramp Capacity Analysis MCP – Alternative 9
- 7-16 Horizon Year (2040) Intersection Capacity Analysis – Alternative 9
- 7-17 Horizon Year (2040) Intersection Capacity Analysis – San Jacinto Design Variation

- 9-1 2030 Roadway Segment Capacity Analysis – No Build
- 9-2 2030 Roadway Segment Capacity Analysis – Alternative 4
- 9-3 2030 Roadway Segment Capacity Analysis – Alternative 5
- 9-4 2030 Roadway Segment Capacity Analysis – Alternative 9

1.0 INTRODUCTION

The Mid County Parkway is a proposed 16-mile transportation corridor that will relieve traffic congestion for east-west travel in Western Riverside County between San Jacinto and Perris and help address future transportation needs through the Year 2040.

This report provides a traffic analysis of the proposed Mid County Parkway (MCP) project located in Western Riverside County. The MCP Corridor will provide a new six-lane limited access freeway that will connect Interstate 215 (I-215) in Perris with State Route 79 (SR-79) in San Jacinto. Figure 1-1 shows the general location of the project.

The project limits were recently re-defined to extend from I-215 to SR-79, instead of SR-79 to Interstate 15 (I-15). This required a complete new traffic analysis. The previous traffic analysis was documented in a Traffic Technical Report dated May 16, 2008.

An analysis of existing traffic conditions in the project study area, as well as future conditions with and without the proposed project are included in this Traffic Technical Report. There are three alternative alignments of the MCP and one design variation currently under study, with possible design variations to be added later. A complete traffic analysis has been provided for each of the alignment alternatives and a limited traffic analysis has been provided for the design variation, focused on roadways and intersections in the immediate vicinity of a design variation.

The remainder of this report provides a description of the study methodology, existing conditions, future traffic forecasts, No Build conditions, Build conditions for various alternatives, and traffic impacts/mitigation. In addition, appendices have been included that contain additional detail on various aspects of the analysis.

The introduction and background information that follows provides a description of the current status and history of the project.

PROJECT INFORMATION

The Riverside County Transportation Commission (RCTC), California Department of Transportation (Caltrans), and the Federal Highway Administration (FHWA), propose to improve east-west transportation in Western Riverside County (County) between I-215 in the west and SR-79 in the east. The proposed project will construct a new freeway, known as the Mid County Parkway (MCP), which will provide a direct and continuous route connecting major population/employment centers as identified in the Land Use Element of the County of Riverside General Plan and the General Plans of the cities of Perris and San Jacinto, a distance of approximately 16 miles (mi).

RCTC is the project proponent and the lead agency under the California Environmental Quality Act (CEQA) and has adopted guidelines for implementing CEQA. FHWA is the lead agency under the National Environmental Policy Act (NEPA), with Caltrans acting as its agent and providing oversight for the NEPA process. Caltrans may also become the owner/operator of the MCP if it is designated as a State Route following construction. RCTC, Caltrans, and FHWA are working in close collaboration with the United States Army Corps of Engineers (USACE), the United States Environmental Protection Agency (EPA), the United States Fish and Wildlife Service (USFWS), and the California Department of Fish and Game (CDFG) in development of the Purpose and Need and the MCP project alternatives.

The MCP project was identified as a key east-west regional transportation corridor as a result of several years of comprehensive land use and transportation planning in Riverside County through the Riverside County Integrated Project (RCIP). The RCIP was an unprecedented, multi-year planning effort to simultaneously prepare environmental, transportation, housing, and development guidelines for Riverside County for the first half of the 21st century. Riverside County is one of the fastest growing counties in the United States. The purpose of the RCIP was to address the planning, environmental, and transportation issues that would result from significant anticipated growth in population in the County. The RCIP planning effort included three components: (1) a new General Plan for Riverside County, which was adopted in October 2003; (2) a Multiple Species Habitat Conservation Plan (MSHCP) for Western Riverside County, which was approved in June 2004; and (3) the Community and Environmental Transportation Acceptability Process (CETAP). CETAP study efforts were jointly undertaken by the RCTC and the County of Riverside as a part of the RCIP. The CETAP included the study of two inter-county corridors including the Riverside County to Orange County and Riverside County to San Bernardino County corridors, as well as two intra-county transportation corridors including a north-south and an east-west corridor in Western Riverside County. Tier 1 analyses and environmental documents were initiated for the two intra-county corridors in the Fall of 2000: (1) a north-south corridor referred to as Winchester to Temecula Corridor, and (2) an east-west corridor known as the Hemet to Corona/Lake Elsinore (HCLE) Corridor. The purpose of the Tier 1 effort was to select preferred alternatives in order to preserve needed right-of-way.

The agencies that participated in the HCLE Corridor study process developed the following purpose of the proposed action in the HCLE Corridor: "to provide multimodal transportation improvements that will help alleviate future traffic demands and congestion and improve the east-west movement of people and goods across Western Riverside County." After a Draft Tier 1 Environmental Impact Report/Environmental Impact Statement (EIR/EIS) was completed for the HCLE Corridor and circulated for public review in 2002 with a suite of 14 "build" alternatives, the RCTC Board accepted a staff recommendation in June 2003 to proceed with accelerated preparation of a project-level environmental document for a east-west alternative that would generally follow the existing alignment of Cajalco Road and Ramona Expressway, known as the MCP project.

Engineering and environmental studies were initiated in 2004 for the MCP project, a proposed 32-mile facility located between I-15 and SR-79. In September 2007, the RCTC Policy Board selected a Locally Preferred Alternative (Alternative 9 Modified Temescal Wash Design Variation) for the MCP project. In October 2008, the Draft EIR/EIS for the MCP project was circulated for a 90-day public review period. During this time, six public meetings/hearings were held. RCTC accepted public comments for the record at all of these meetings, along with comments via the MCP project website and email. Over 3,100 comments were received from 50 public agencies and organizations, 10 large property owners, 240 individuals, and a form letter from over 1,100 individuals nationwide.

The following two key themes emerged in the public review comments:

1. Concern about the cost and timing of available funds for the project. Many comments noted that, given the current economy and difficulty in securing funding for the entire project, limited financial resources should be focused on areas of greatest need.
2. Although public comments raised concerns about many aspects of the project throughout its entire length, many comments suggested that making improvements to existing facilities rather than building the MCP facility would be a better expenditure of public funding in the western portion of the project area between I-15 and I-215. In this area, improving existing facilities, such as Cajalco Road, instead of building the MCP facility would minimize impacts to the rural communities of Gavilan Hills and Lake Mathews Estates, as well as existing habitat reserves. Impacts to rural communities and existing habitat reserves were two major concerns raised in the public comments.

To address the concerns identified above, in the Spring of 2009, RCTC as the lead agency under CEQA, FHWA as the lead agency under NEPA, and Caltrans acting as an agent and providing oversight for the NEPA process, developed an approach for completing the EIR/EIS process for the project. This approach modified the MCP project limits from 32 miles (I-15 to SR-79) to 16 miles (I-215 to SR-79) in order to focus transportation funding where the need is the greatest, between I-215 to SR-79, near existing facilities (i.e., Ramona Expressway). This approach also includes preparation of a Recirculated Draft EIR/Supplemental Draft EIS that would revise the project purpose statement and modify the project alternatives. RCTC recognizes that while the need for transportation improvements still exists between I-15 and I-215, the Riverside County Transportation Department's proposed widening improvements to Cajalco Road will alleviate a portion of that need. The greatest near-term need for east-west transportation improvements is east of I-215, even with planned improvements along the existing Ramona Expressway. Therefore, the project purpose for the modified MCP project focuses on the need for transportation improvements between I-215 and SR-79. I-215 and SR-79 provide logical termini for the MCP project, and the project has independent utility even if additional transportation improvements are not made in the area. This approach for completing the EIR/EIS process for the modified MCP project was reviewed with the federal and State resource and regulatory agencies involved in the project (USACE, EPA, USFWS, and CDFG).

Fundamental to modification of the MCP project purpose statement and alternatives is the assumption that improvements between I-15 and I-215 are not planned, designed, or intended to be implemented as part of the MCP project. The distinct transportation needs between I-15 and I-215 will be addressed by the Riverside County Transportation Department's General Plan roadway improvements for Cajalco Road. The Cajalco Road improvement project would be subject to a separate environmental review process in the future with the Riverside County Transportation Department acting as the lead agency. The Cajalco Road improvements will be analyzed in the MCP cumulative impacts assessment using the most current information available from the County. A CETAP corridor between I-15 and I-215 would remain in the Regional Transportation Plan (RTP) so as to not preclude consideration of transportation improvements to address future needs beyond those being addressed by the Cajalco Road improvements.

On July 8, 2009, the RCTC Board formally took action to refocus the MCP project between I-215 and SR-79. As a result of the RCTC's Board action, a Recirculated Draft EIR/Supplemental Draft EIS is being prepared for the modified project. Public and agency comments previously submitted for the October 2008 Draft EIR/EIS will be included in the MCP Administrative Record, but no formal responses will be prepared. However, any comments applicable to the modified MCP project will be addressed in the Recirculated Draft EIR/Supplemental Draft EIS. Any comments received during the public review period of the Recirculated Draft EIR/Supplemental Draft EIS will be formally responded to prior to the Final EIR/EIS.

To address the modified project, the MCP purpose and need statement has been revised and three modified Build Alternatives have been defined and evaluated that consist of a freeway facility from I-215 to SR-79 (these modified alternatives will follow the alignments for original Alternatives 4, 5, and 9 east of I-215). Fundamental to the modified project purpose statement and alternatives is that no improvements between I-15 and I-215 will be planned or analyzed as part of the MCP project.

The Southern California Association of Governments' (SCAG's) RTP and Regional Transportation Improvement Program (RTIP) have been modified to match the focused project description for the MCP modified project. Additionally, given that projected travel demand west of I-215 still identifies a need for infrastructure improvements, even with the County's planned improvements to Cajalco Road, a CETAP corridor is in the RTP so as to not preclude consideration of future transportation improvements. Other projects planned in Western Riverside County such as the I-15 Corridor Improvement Project (CIP) and State Route 91 (SR-91) Capital Improvement Program (CIP) assume a 32-mile corridor from I-15 through I-215 to SR-79, as these projects were underway when the MCP project was modified in June 2008. This assumption remains consistent with the updated RTP and RTIP, which both assume a "32-mile corridor", even though it is a combination of two separate distinct corridors and noted as such in these documents: (1) the MCP modified project between I-215 and SR-79 and (2) a future west-east CETAP corridor between I-15 and I-215.

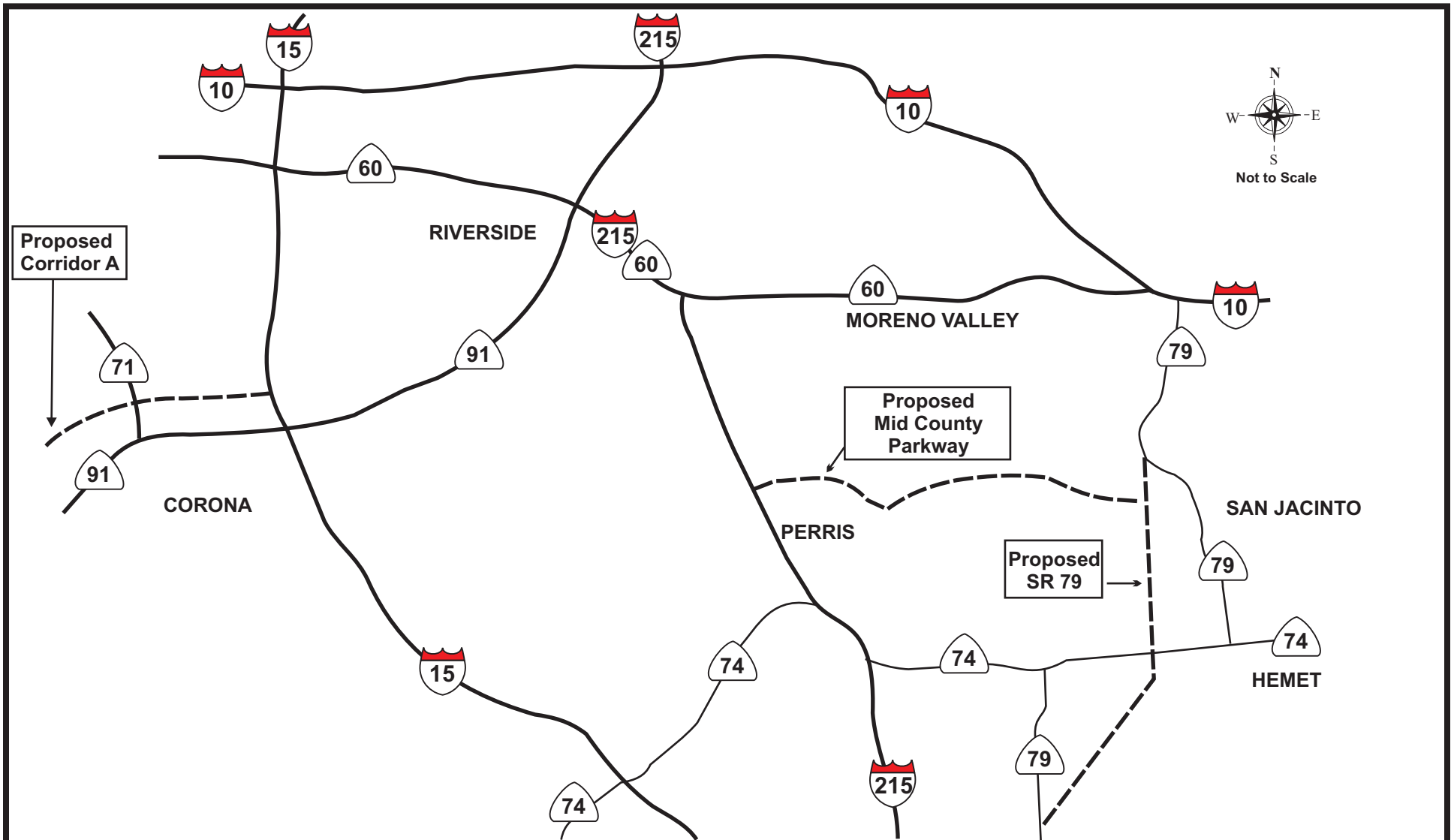

In order for the MCP modified project to analyze the potential worst case and near-term project impacts to I-215 and the local circulation network with implementation of the proposed modified project, the MCP project analyses do not assume an east-west CETAP corridor between I-15 and I-215. Traffic analyses for a 32-mile corridor from I-15 to SR-79, essentially an east – west CETAP corridor (I-15 to I-215) and a modified MCP (I-215 to SR-79) were previously completed with the original MCP Draft EIR/EIS circulated in October 2008, which assumed a full 32-mile facility connecting I-15, I-215, and SR-79.



Project Location

Figure 1-1

Legend

-  Existing Limited Access Roadway
-  Proposed Limited Access Roadway
-  Existing Arterial Roadway



2.0 METHODOLOGY

This chapter provides an overall description of the methodology and assumptions used to prepare the traffic analysis for the Mid County Parkway (MCP). It is divided into sections that describe various aspects of the analysis.

OPENING YEAR OF PROJECT

The assumed project opening year is 2020 and the horizon year for traffic forecasts is 2040, twenty years after opening day, as required by the Federal Highway Administration (FHWA) and the California Department of Transportation (Caltrans).

PROJECT DESIGN CONCEPT

The location of the proposed MCP modified project is shown in Figure 1-1. The project will be built as a roadway facility with grade separations provided for crossing roadways and access allowed only at interchanges. The project will extend from Interstate 215 (I-215) in Perris to State Route 79 (SR-79) in San Jacinto. The number of lanes to be provided was determined according to expected traffic demand. The current proposal is to provide six mixed-flow lanes (three lanes in each direction) throughout the length of the project.

PROJECT ALTERNATIVES

The following project alternatives were analyzed at the same level of detail and were given equal consideration in the traffic analysis. All of the alternatives follow a common alignment along the Ramona Expressway corridor from SR-79 west to the Placentia Avenue/Evans Road intersection area and vary as follows:

- ◆ Alternative 4 Modified Modified (Perris Drain), Figure 2-1: Runs from Placentia Avenue/Evans Road west of and parallel to the Perris Valley Drain and then north of and parallel to the Ramona Expressway to reach I-215
- ◆ Alternative 5 Modified Modified (Rider), Figure 2-2: Runs from Placentia Avenue/Evans Road along the Rider Avenue alignment to reach I-215
- ◆ Alternative 9 Modified Modified (Placentia), Figure 2-3: Runs from Placentia Avenue/Evans Road parallel to Placentia Avenue to reach I-215

There is one project design variation that would affect the traffic analysis for the project (the SR-79/MCP Interchange Design Variation) and it is shown in Figure 2-4.

During the course of project development, it is possible that design variations will be added. Additional traffic analysis may be conducted to document the traffic characteristics of any added design variations.

INTERCHANGES

Interchanges will be provided at the following locations:

- ◆ I-215
- ◆ Perris Blvd/Redlands Ave (interchange will be located at Perris Blvd in Alternatives 4 and 5 and at Redlands Ave in Alternative 9 Modified)
- ◆ Evans Rd
- ◆ Ramona Expressway (Antelope Rd)
- ◆ Bernasconi Rd
- ◆ Reservoir Ave
- ◆ Town Center Blvd (proposed new roadway)
- ◆ Park Center Blvd (proposed new roadway)
- ◆ Warren Rd
- ◆ SR-79

Other assumptions regarding interchanges include:

- ◆ A new interchange at I-215/Placentia Avenue was included as part of the proposed MCP project. This interchange was included in all MCP Build alternatives.
- ◆ The existing I-215/Cajalco Expressway/Ramona Expressway interchange was assumed to remain and will be improved as part of the proposed MCP project. This interchange was included in all MCP Build alternatives. The need for including improvements as part of the MCP project was evaluated on a case-by-case basis.

TRAFFIC ANALYSIS SCENARIOS

The traffic analysis was conducted for existing (2010) conditions, opening year (2020) conditions, and horizon year (2040) conditions for the No Build and the three Build Alternatives. In order to comply with NEPA and CEQA guidelines, the No Build analysis was conducted for two scenarios of roadway conditions along the Ramona Expressway: (1) existing conditions, and (2) with improvements corresponding to the Riverside County General Plan. In order to be consistent with previous environmental documents prepared for the project, the No Build alternatives were designated Alternative 1A Modified – No Build/Existing Conditions and Alternative 1B Modified – No Build/County General Plan.

For Alternative 1A Modified – No Build/Existing Conditions, only the Ramona Expressway was assumed to remain in its existing condition, since it coincides with the MCP corridor. All other city and County roadways were assumed to be improved to the level consistent with planning and programming for roadway improvements for years 2020 and 2040.

ROADWAY NETWORK

For the horizon year (2040) analysis, freeways and State highways generally were assumed to be improved according to the SCAG 2008 Regional Transportation Plan (RTP) (see Appendix A and Table 2-1). The assumptions included all SCAG 2008 RTP Amendments through Amendment 4 approved on November 4, 2010.

Roadways other than freeways and State highways were assumed to be improved according to local agency General Plan Circulation Elements.

The assumed roadway network includes realignment and improvement of SR-79 to a four-lane freeway, as shown in Figure 2-5. Expected lane geometry for other major roadways in the study area is also shown in Table 2-1.

STUDY AREA

The study area generally includes the MCP mainline, MCP ramps, and ramp terminal intersections with local cross streets. In addition, one intersection to the north and south of the MCP was included in the study area. Because of the need to provide information on I-15 and I-215, the study area was extended to two interchanges north and south of the MCP on each of these facilities. In addition, because of the potential impact of the MCP on Cajalco Road, the section of Cajalco Road from I-15 to I-215 was included. Finally, selected segments of parallel freeways were included for the purpose of examining traffic forecasts on these facilities with and without the MCP, as shown in Figure 2-6.

It is recognized that traffic analysis may be needed for locations outside the study area described above. Following general agreement on the traffic analysis provided in this draft of the Traffic Technical Report, the study area may be enhanced to cover additional areas.

CAPACITY ANALYSIS

Roadway capacity analysis was conducted using Highway Capacity Software 2000 (HCS 2000) and the Synchro traffic signal timing program. HCS 2000 was used for freeways and Synchro was used for signalized and unsignalized intersections. Tables 2-2 and 2-3 list general assumptions for individual parameters used in the freeway and ramp analysis, as well as the signalized intersection analysis.

Additional information regarding the roadway capacity analysis includes the following:

- ◆ A separate capacity analysis was not conducted for roadway segments. The number of through lanes needed on roadway segments was determined by first conducting intersection capacity analysis to determine the number of through lanes needed at key intersections. The number of through lanes needed at key intersections was then used to define the number of lanes needed for the intervening roadway segments.

- ◆ The desirable level of service (LOS) threshold for design purposes will be LOS D. Therefore, a LOS result of A, B, C, or D will be considered to indicate acceptable traffic operations and a LOS result of E or F will be considered as an indication that further roadway improvements should be investigated. In some cases, the lane geometry recommended for a particular intersection exceeds the minimum required lane geometry to provide level of service D. This was done for varying reasons including lane balance, minimizing delay where right-of-way is available, and to provide adequate storage length for left turn movements.

TRUCK PERCENTAGES

Truck percentages were determined as follows:

- ◆ Based on the previous MCP traffic analysis and the Riverside County Integrated Plan (RCIP) traffic analysis, truck percentages on freeways and ramps are assumed to be 5%, buses were assumed to be 1%, and recreational vehicles (RV's) were assumed to be 1%. The 5% truck factor is based on the Community and Environmental Transportation Acceptability Process/Riverside County Integrated Plan (CETAP/RCIP) process, which also used the same percentage. The applied 5% truck factor was also based on the I-215 Widening Project from I-15 to Nuevo Road, which counted 4% trucks on I-215 south of Newport Road. The percentages of trucks, buses, and RV's described above are documented in Table 2-2- and were used for freeway and ramp capacity analysis.
- ◆ For expressways, arterial streets, and local roadways, a truck percentage of 3% was generally applied. This percentage is based on recent research that is expected to be incorporated in future editions of the Highway Capacity Manual (NCHRP Report 599 – Default Values for Highway Capacity and Level of Service Analyses). The 3% truck percentage used for signalized intersections is documented in Table 2-3.

ROUNDING OF TRAFFIC FORECASTS

Certain rounding conventions were used in this report for ease of presentation:

- ◆ Average Daily Traffic forecasts were rounded to the nearest 100
- ◆ Average Daily Traffic forecasts for freeways were assumed to be split evenly by direction

These rounding conventions were also applied to existing conditions.

OPENING YEAR (2020) PHASED PROJECT

The proposed 2020 project is an interim phased MCP project that would include a four-lane arterial roadway from one half mile west of Reservoir Avenue to one half mile west of Warren Road, a four-lane arterial roadway from one half mile west of Bernasconi Road to one half mile west of Reservoir Avenue, an interchange at I-215/Placentia Avenue, and one additional lane in each direction on I-215 from Nuevo Road to Van Buren Boulevard (see Figure 2-7). The improvements proposed in the 2020 project are common to Alternatives 4, 5, and 9. Roadway network assumptions for key roadways other than the project are listed in Table 2-4.

The traffic analysis for Alternatives 4, 5, and 9 is the same for 2020. Therefore, there is only one 2020 Build analysis included in the study. If the phased 2020 project is built as described in this report, it would be possible to construct the remainder of the project improvements to match either Alternative 4, Alternative 5, or Alternative 9 without changing any of the phased 2020 improvements.

The opening year (2020) traffic analysis required some special considerations since the Riverside Traffic Analysis Model (RIVTAM) model does not currently have a version related to 2020 conditions. The process described below was used to create a 2020 version of the RIVTAM model that was used as the basis for preparing 2020 traffic forecasts.

The SCAG regional transportation model does have a 2020 version and the zone boundaries of the RIVTAM model have been defined so that each SCAG model traffic analysis zone (TAZ) is made up of several smaller RIVTAM model TAZ's. Therefore, the SCAG 2020 regional model was used to estimate RIVTAM 2020 conditions.

Following is a description of the methodology used for opening day conditions:

- ◆ Socioeconomic forecasts for 2020 conditions were determined in consideration of the socioeconomic forecasts from the SCAG regional transportation model and the RIVTAM model for various horizon years. The methodology was as follows:
 - For each RIVTAM TAZ, future growth through 2035 was determined by subtracting base year data from 2035 data. The amount of growth that occurred from the base year to 2035 was calculated separately for each parameter used as input to the SCAG and RIVTAM models (i.e. population, dwelling units, total employment, etc.). The remainder of the calculations focused on estimating the amount of this growth that will occur by 2020.
 - For each SCAG TAZ in the MCP corridor study area, socioeconomic data was obtained for the base year, 2020, and 2035. Based on this data, the percentage of growth that will occur from the base year to 2020 was determined. This percentage of growth was applied to each of the RIVTAM TAZ's within the SCAG TAZ to estimate 2020 data for the RIVTAM TAZ's. This calculation was conducted separately for each parameter used as input to the SCAG and RIVTAM models so that the percentage of growth that occurs by 2020 is different for each parameter.
 - For SCAG TAZ's outside Riverside County, the SCAG 2020 data was used directly because the SCAG TAZ's are the same as the RIVTAM TAZ's for other counties in the SCAG and RIVTAM models.
- ◆ The 2020 roadway network for the RIVTAM model was developed by starting with the roadway network in the base year model. Roadway improvements were added if they fell into one of the following categories:
 - Roadway improvements identified in the SCAG Regional Transportation plan as scheduled to occur prior to 2020.

- Roadway improvements listed in City/County five-year capital improvement programs.
- Additional roadway improvements were identified on a case-by-case basis if the responsible agency has a secure funding source and has reasonable assurances that the improvement will be in place by 2020.

The approximate study area boundaries for consideration of roadway improvements were generally the same study area boundaries as described above for refinement of the 2035 RIVTAM model: SR-91/SR-60 on the north, SR-79 on the east, I-215 and Nuevo Road/I-15 and Temescal Canyon Road on the south, and I-15 on the west.

The overall intent on roadway network assumptions is to provide a conservative analysis. Therefore, if there is a question regarding whether a particular roadway improvement will be in place in 2020, the conservative answer was generally followed and the roadway improvement was assumed not to be in place.

Other than the details described above, the 2020 opening year traffic analysis was conducted for the same scenarios and using the same methodology as the 2040 horizon year analysis.

2030 PROJECT PHASING ASSUMPTIONS

In addition to the Opening Year (2020) and Horizon Year (2040) traffic analyses, a traffic analysis was conducted for a phased implementation of the project in 2030. This analysis is described in Chapter 9.

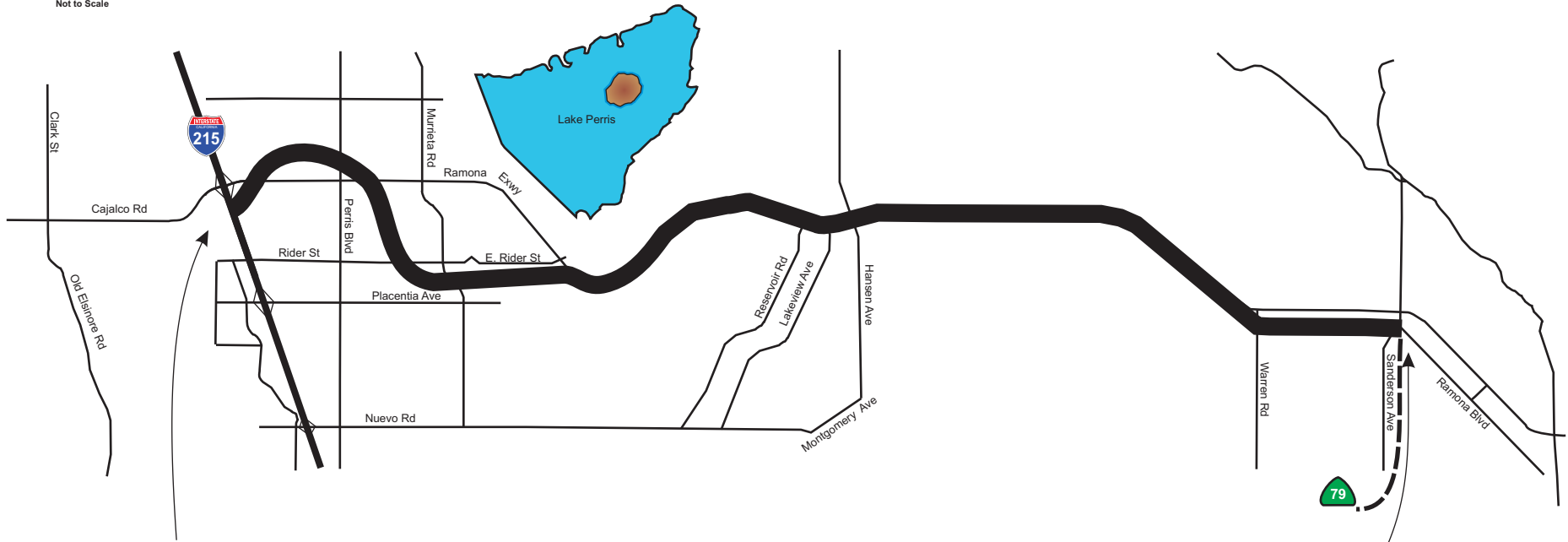

I-215/MCP Interchange:
Perris Drain Alternative

SR-79/MCP Interchange:
South Alternative

Alternative 4: Modified (Perris Drain)

Figure 2-1

Legend

-  Proposed Mid County Parkway
-  Proposed SR-79



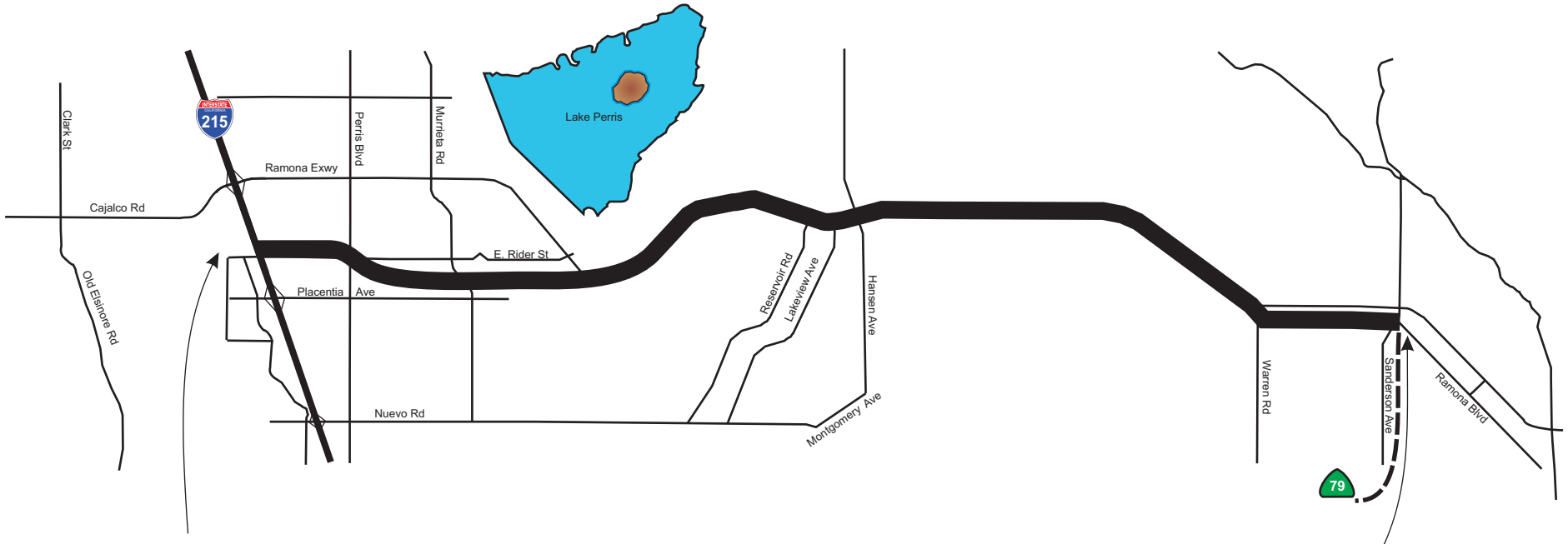



I-215/MCP Interchange:
Rider Alternative

SR-79/MCP Interchange:
South Alternative

Alternative 5: Modified (Rider)

Figure 2-2

Legend

-  Proposed Mid County Parkway
-  Proposed SR-79



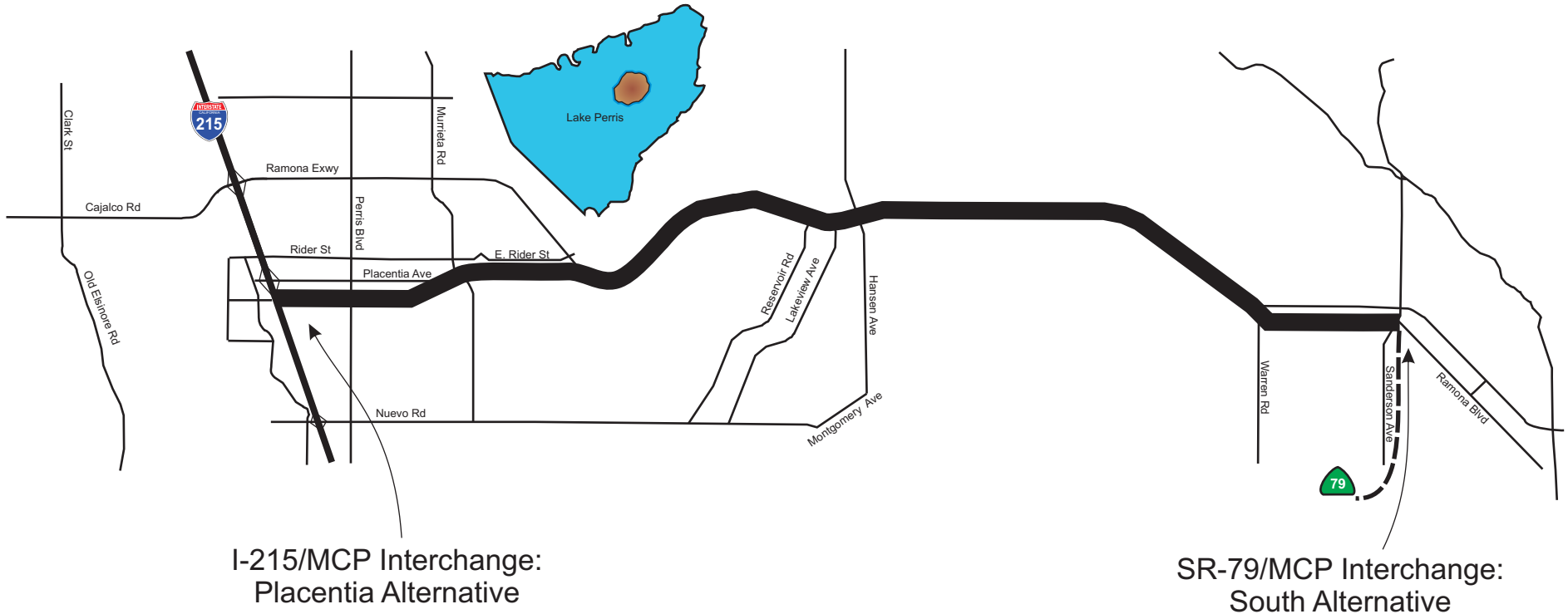

Alternative 9: Modified (Placentia)

Figure 2-3

Legend

-  Proposed Mid County Parkway
-  Proposed SR-79



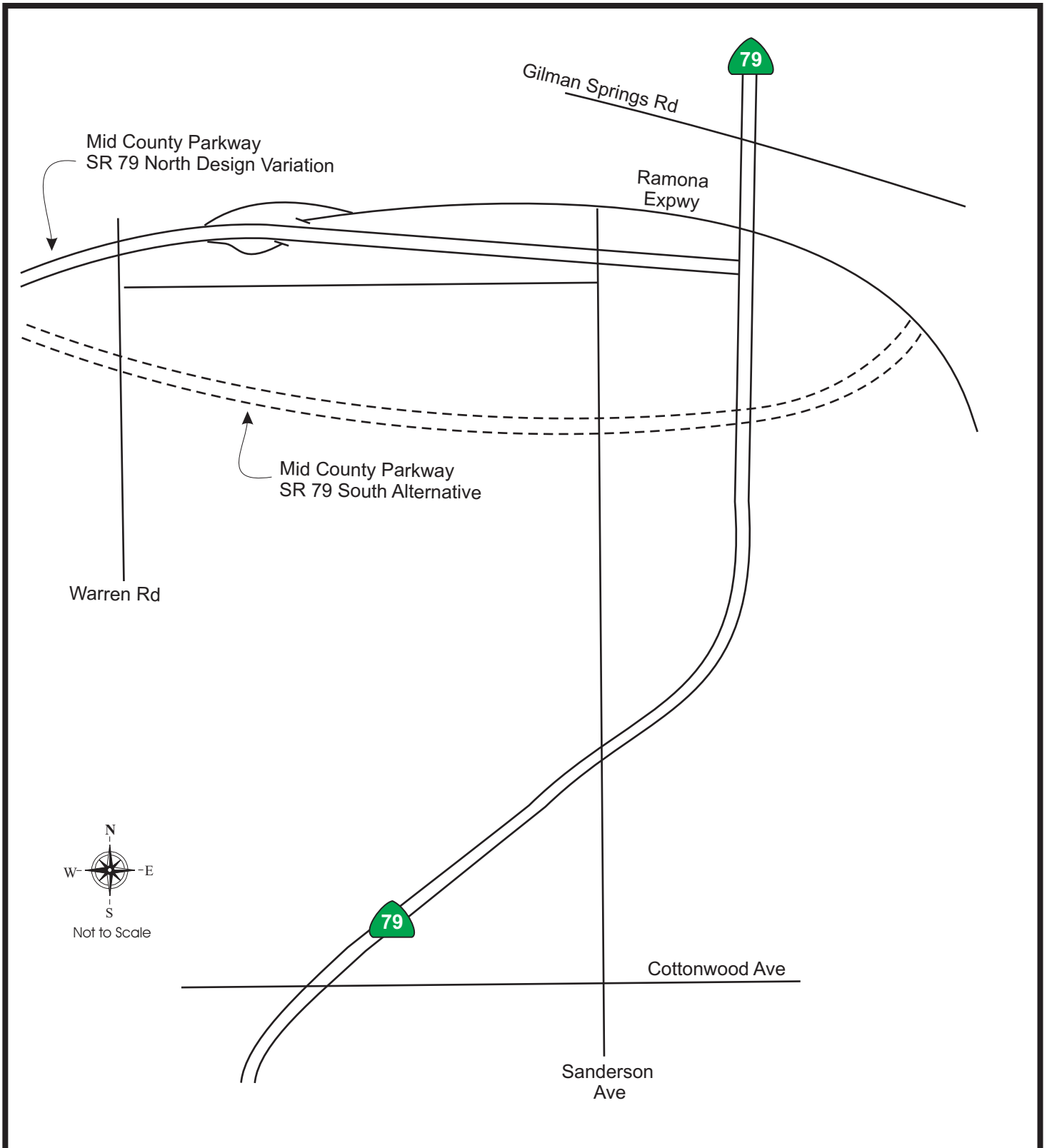

**SR 79/MCP Interchange
North Design Variation**

Figure 2-4

Legend

- ==== Freeway/Parkway
- MCP Basic Alignment
- Arterial Street



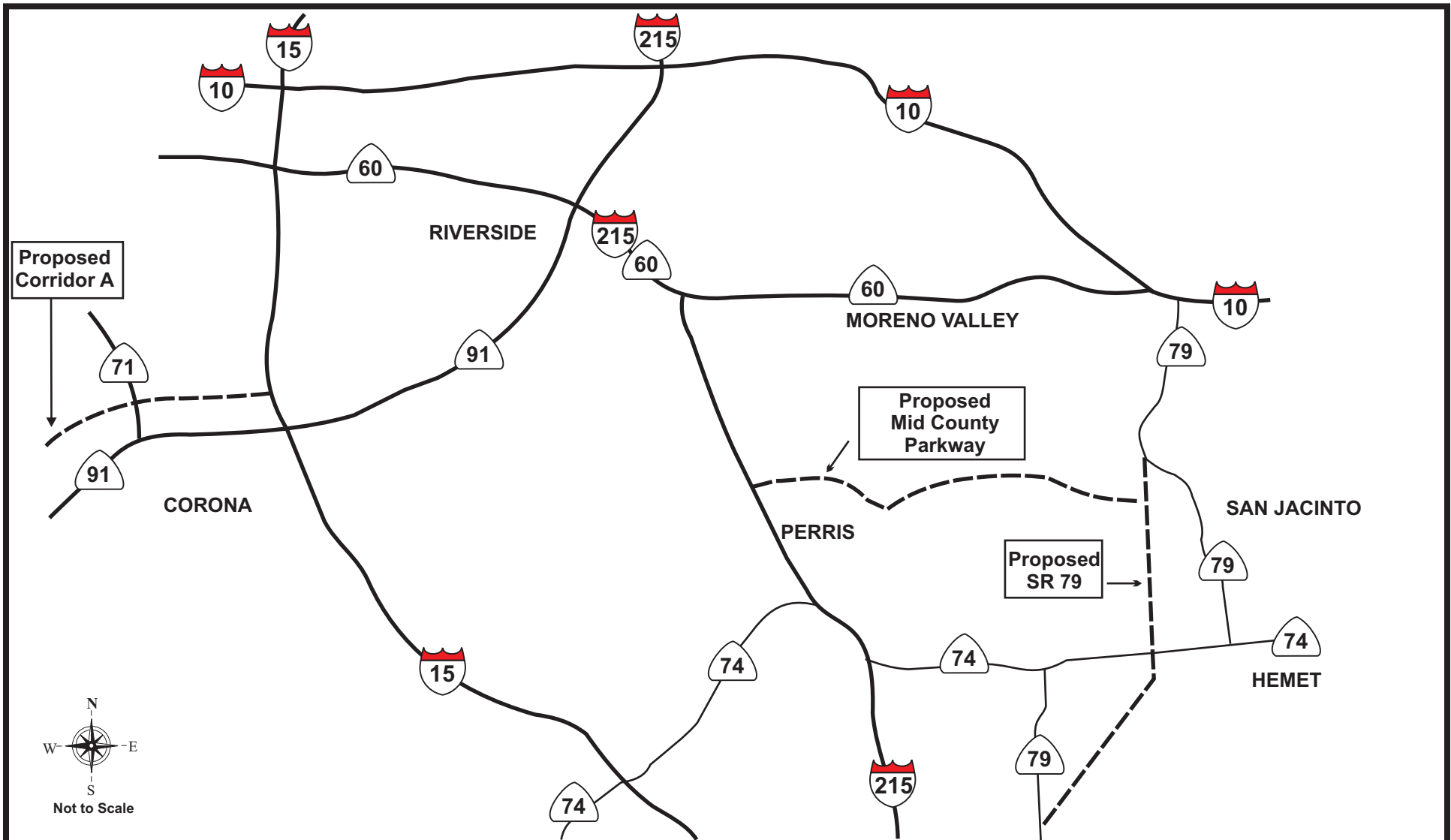



2040 Roadway Network Assumptions

Figure 2-5

Legend

-  Existing Limited Access Roadway
-  Proposed Limited Access Roadway
-  Existing Arterial Roadway



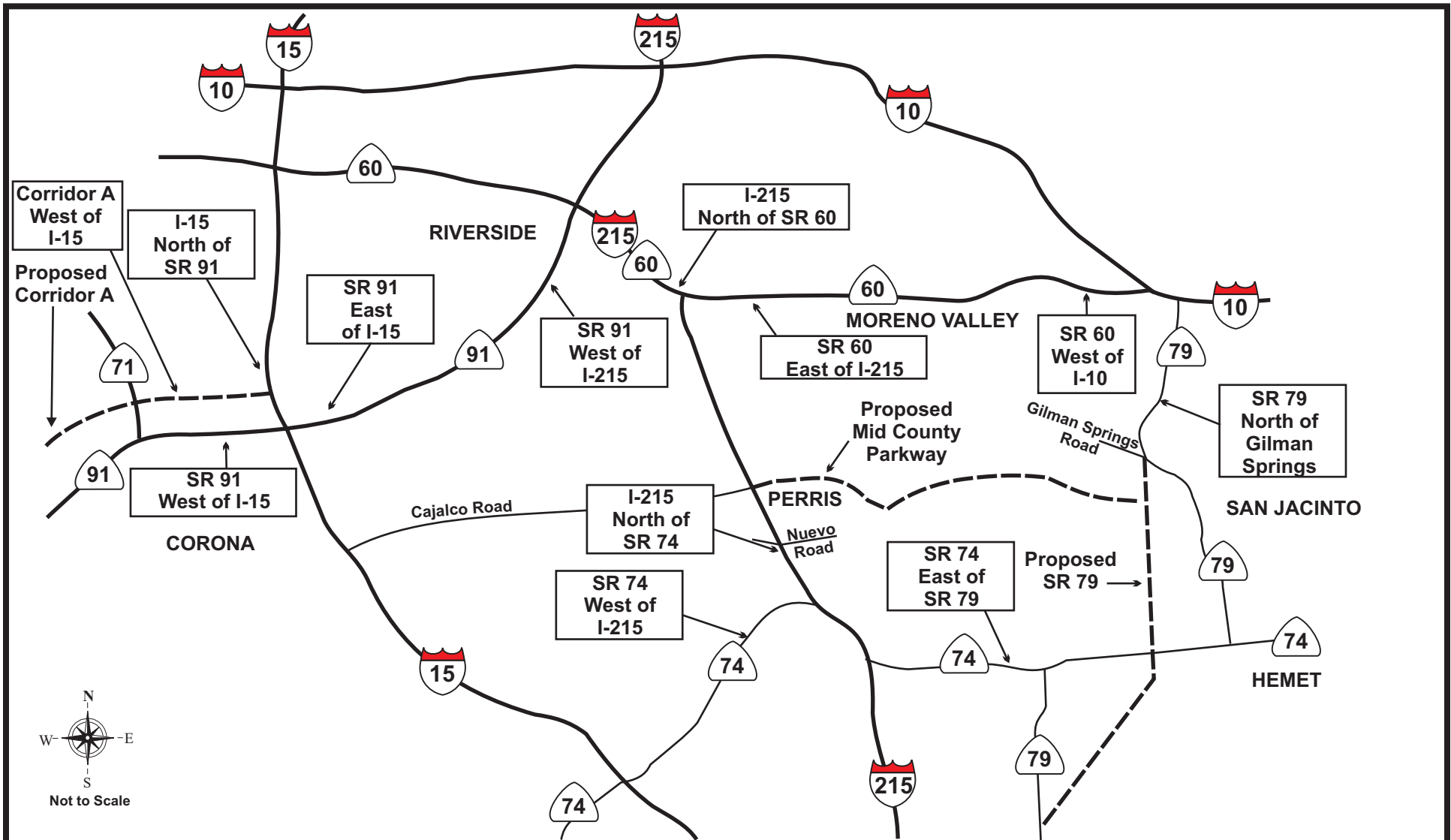

Roadway Segment Analysis Outside MCP Project Area

Figure 2-6

Legend

- Existing Limited Access Roadway
- - - Proposed Limited Access Roadway
- Existing Arterial Roadway



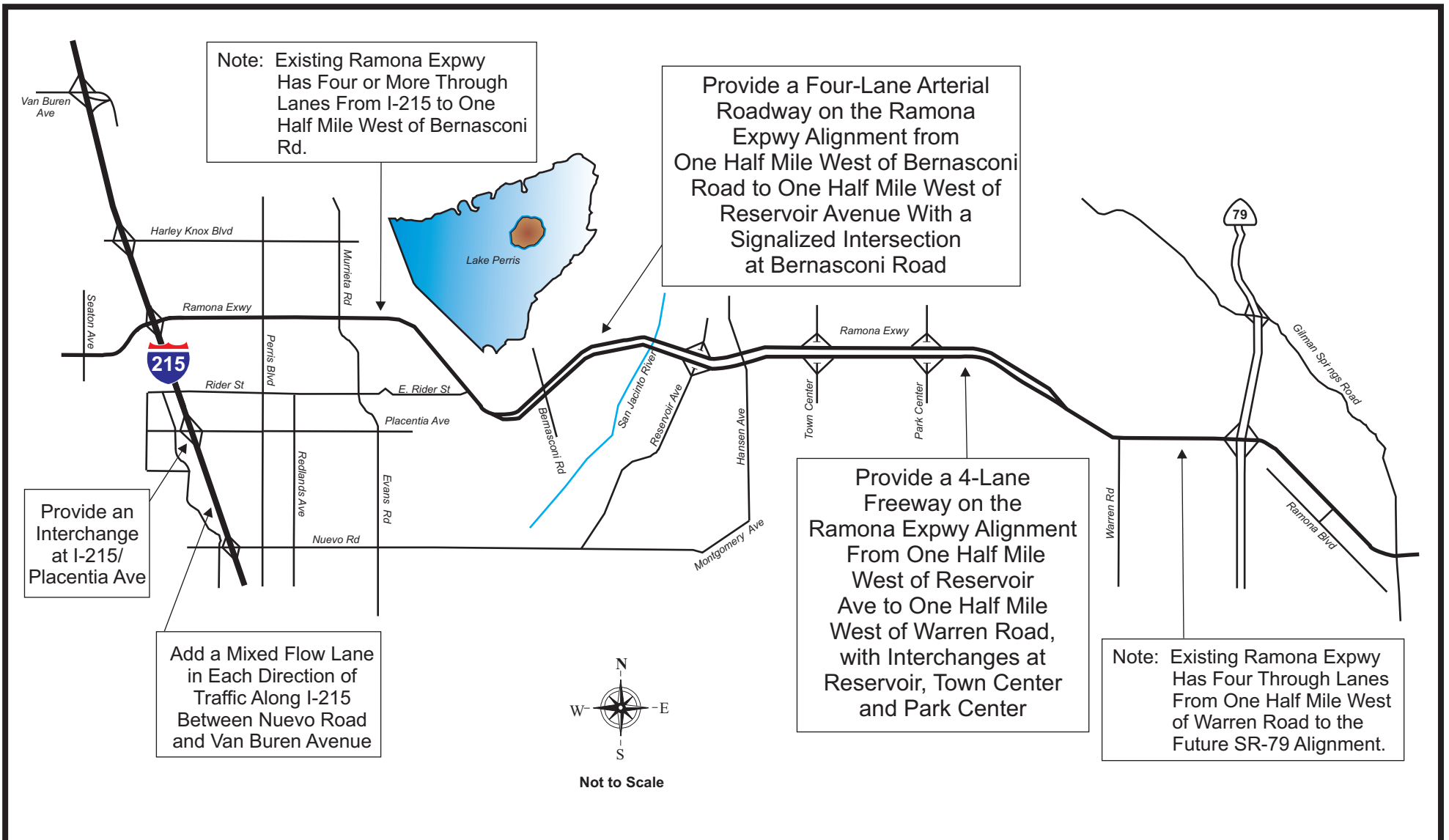

Mid County Parkway Opening Year (2020) Proposed Project Description

Figure 2-7

LEGEND

———— Existing or Proposed Roadway



Table 2-1

Mid County Parkway Traffic Analysis

2040 Regional Roadway Network Assumptions

Source: 2008 SCAG Regional Transportation Plan and VRPA Technologies

<u>Roadway</u>	<u>Limits</u>	<u>Lane Geometry</u>
I-15	I-215 to SR-74 SR-74 to SR-91 SR-91 to SR-60	6 MF + 2 HOV 8 MF + 4 EXP 8 MF + 4 EXP
I-215	I-15 (Temecula) to Nuevo Rd Nuevo Rd to SR-60 (Moreno Valley) SR-60 (Moreno Valley) to SR-91	6 MF 6 MF + 2 HOV 6 MF + 2 HOV (1)
SR-91	I-215 to I-15 I-15 to Orange Co. Line	6 MF + 2 HOV 10 MF + 4 EXP
SR-60	I-10 to Gilman Springs Rd Gilman Springs Rd to Perris Blvd Perris Blvd to I-215	4 MF + EB TRUCK LANE 4 MF 4 MF + 2 HOV
SR-79	Domenigoni Pkwy to Gilman Springs Rd	4 MF
I-15/SR-91	Interchange	Add NB-WB, EB-SB, EB-NB, and SB-WB EXP Connectors
Cajalco Rd	I-215 to I-15	6 MF (Arterial)
CETAP Corridor	I-215 to I-15	Not Included in Network (2)
Corridor A	I-215 to SR-241	4 EXP

Notes:

MF = Mixed Flow Lanes

EXP = Express Lanes (High Occupancy Vehicle/Toll)

HOV = High Occupancy Vehicle Lanes

All roadways are freeways except Cajalco Road

All assumptions are based on SCAG 2008 Regional Transportation Plan, with amendments.

- (1) Includes southbound truck lane east of University in addition to the lanes indicated.
- (2) The SCAG 2008 Regional Transportation Plan includes implementation of a new limited access facility in the CETAP corridor between I-15 and I-215, but it was not assumed to be in place for the Mid County Parkway traffic study in order to provide a conservative analysis.

Table 2-2

FREEWAY AND RAMP CAPACITY ANALYSIS ASSUMPTIONS

Parameter	Default Value Used in Study
Design Speed	70 mph
Terrain	Flat
% Trucks	5%
% Buses	1%
% RVs	1%
Peak Hour Factor	0.95
Driver Population Factor	1.00
Lane Width	12 Feet
Lateral Clearance	12 Feet +

Table 2-3

INTERSECTION CAPACITY ANALYSIS ASSUMPTIONS

Parameter	Default Value Used in Study
Lane Width	12 Feet
Cycle Length	120 Seconds
Yellow Time	4 Seconds
All Red Time	1 Seconds
Right Turn on Red	Determined by Synchro
Type of Signal	Actuated
Grade	0%
Peak Hour Factor (PHF)	0.92
Percent Buses	0 Buses/Hr
Percent Heavy Vehicles	3%
Conflicting Pedestrian Flow	None
Parking	None

Table 2-4

Mid County Parkway Traffic Analysis

2020 Regional Roadway Network Assumptions

<u>Roadway</u>	<u>Limits</u>	<u>Lane Geometry</u>
I-15	I-215 to SR-74 SR-74 to SR-91 SR-91 to SR-60	6 MF + 2 HOV 8 MF + 4 EXP 8 MF + 4 EXP
I-215	I-15 (Temecula) to SR-60 (Moreno Valley) SR-60 (Moreno Valley) to SR-91	6 MF (1) 6 MF + 2 HOV (2)
SR-91	I-215 to I-15 I-15 to Orange Co. Line	6 MF + 2 HOV 10 MF + 4 EXP
SR-60	I-10 to Gilman Springs Rd Gilman Springs Rd to Perris Blvd Perris Blvd to I-215	4 MF + EB TRUCK LANE 4 MF 4 MF + 2 HOV
SR-79	Domenigoni Pkwy to Gilman Springs Rd	4 MF Expressway (3)
I-15/SR-91	Interchange	Add NB-WB, EB-SB, EB-NB, and SB-WB EXP Connectors
Cajalco Rd	I-215 to I-15	4 MF (Arterial)
CETAP Corridor	I-215 to I-15	Not Included in Network

Notes:

MF = Mixed Flow Lanes

EXP = Express Lanes (High Occupancy Vehicle/Toll)

HOV = High Occupancy Vehicle Lanes

All roadways are freeways except Cajalco Road and SR-79

All assumptions are based on SCAG 2008 Regional Transportation Plan, with amendments, except as clarified below.

- (1) The SCAG 2008 RTP indicates a lane geometry of 6MF + 2HOV from SR-60 to Nuevo Road by 2020, but RCTC is planning to extend this improvement to beyond 2020.
- (2) Includes southbound truck lane south of University in addition to the lanes indicated.
- (3) For the purposes of this study, the SR-79 Realignment Project was assumed to include a four-lane expressway from Domenigoni Parkway to Gilman Springs Road with grade-separated interchanges at Ramona Expressway, SR-74/Florida Avenue, and Domenigoni Parkway based on RCTC's current plans for SR-79.

3.0 EXISTING CONDITIONS

This chapter documents existing traffic conditions. Existing conditions considered 2010 traffic and roadway conditions. Portions of the study area were under construction at the time of the traffic analysis and the conditions described in this report document traffic conditions as of April 2010.

LANE GEOMETRY

Figures 3-1 and 3-2 show existing freeway mainline lane geometry for Interstate 15 (I-15) and Interstate 215 (I-215). Figure 3-3 shows existing intersection lane geometry in the traffic analysis study area. This information was based on field reviews conducted by VRPA Technologies, Inc. (VRPA).

AVERAGE DAILY TRAFFIC CONDITIONS

Figures 3-4 and 3-5 show Existing Average Daily Traffic (ADT) within and outside of the Mid County Parkway (MCP) area. Existing ADT values along State Highways were taken from 2009 Caltrans State Highway information, prepared by the Caltrans Traffic and Vehicle Data Systems Unit and published on the Caltrans website at <http://www.dot.ca.gov/hq/traffops/saferesr/trafdata/index.htm>. Due to the current economic downturn and lack of growth in traffic patterns, 2009 traffic data is considered to reflect 2010 traffic conditions. Existing ADT on local streets was estimated based on PM peak hour turning movements. The PM peak hour was assumed to be 10% of ADT.

Capacity analysis of existing freeway segments/ramps along I-15 and I-215 is shown in Tables 3-1 and 3-2.

PEAK HOUR TRAFFIC CONDITIONS

Existing AM and PM peak hour intersection turning movements were collected by VRPA in 2010. Figures 3-6 through 3-8 show existing peak hour traffic conditions along I-15, I-215, and at intersections. Table 3-3 shows intersection capacity analysis for existing conditions.

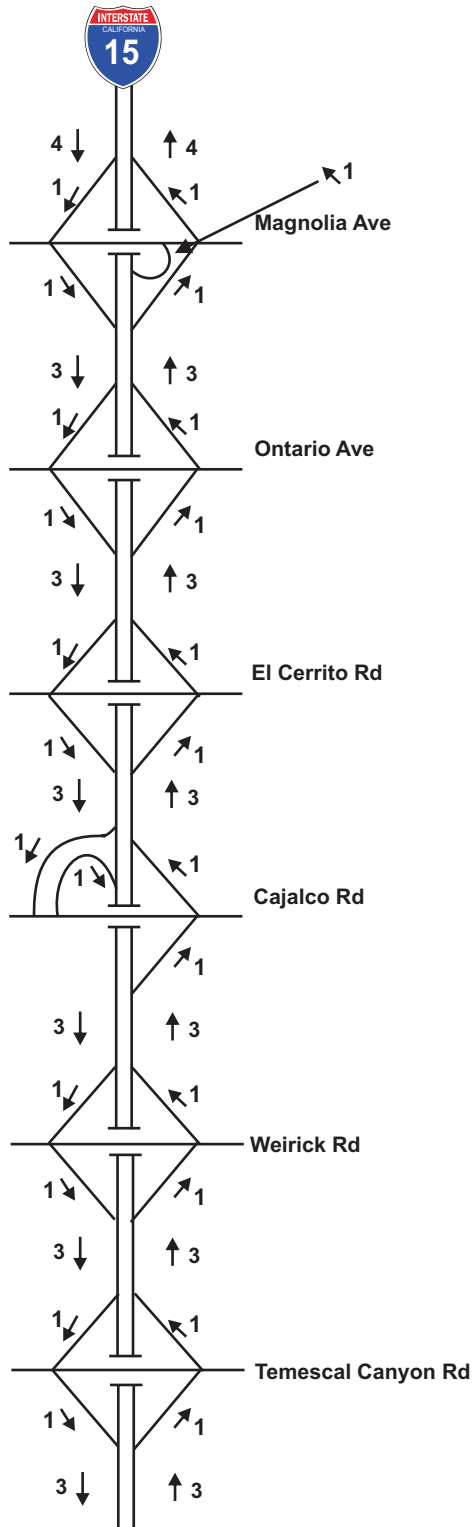

Existing (2010) Freeway Mainline Lane Geometry - Interstate 15

Figure 3-1

Legend

← X Number of Lanes



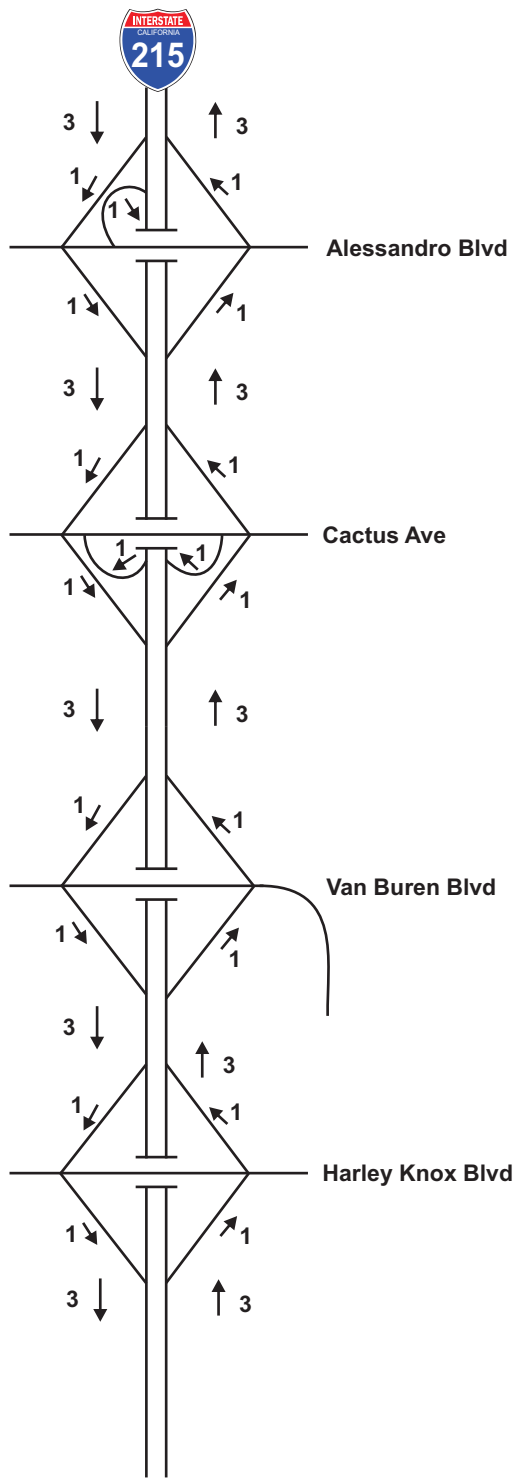

**Existing (2010) Freeway Mainline
Lane Geometry - Interstate 215**

Figure 3-2a

Legend
 → Direction of Travel
 X : Number of Lanes (Mixed Flow)



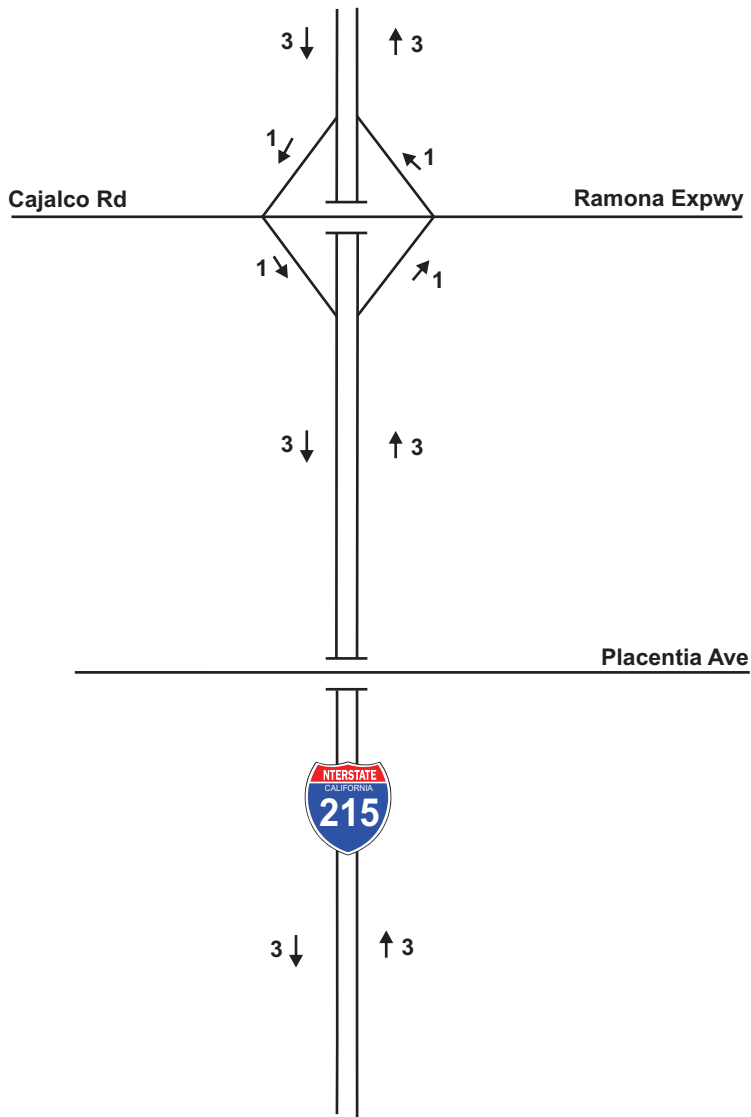

**Existing (2010) Freeway Mainline
Lane Geometry - Interstate 215**

Figure 3-2b

- Legend**
- Direction of Travel
 - X : Number of Lanes (Mixed Flow)



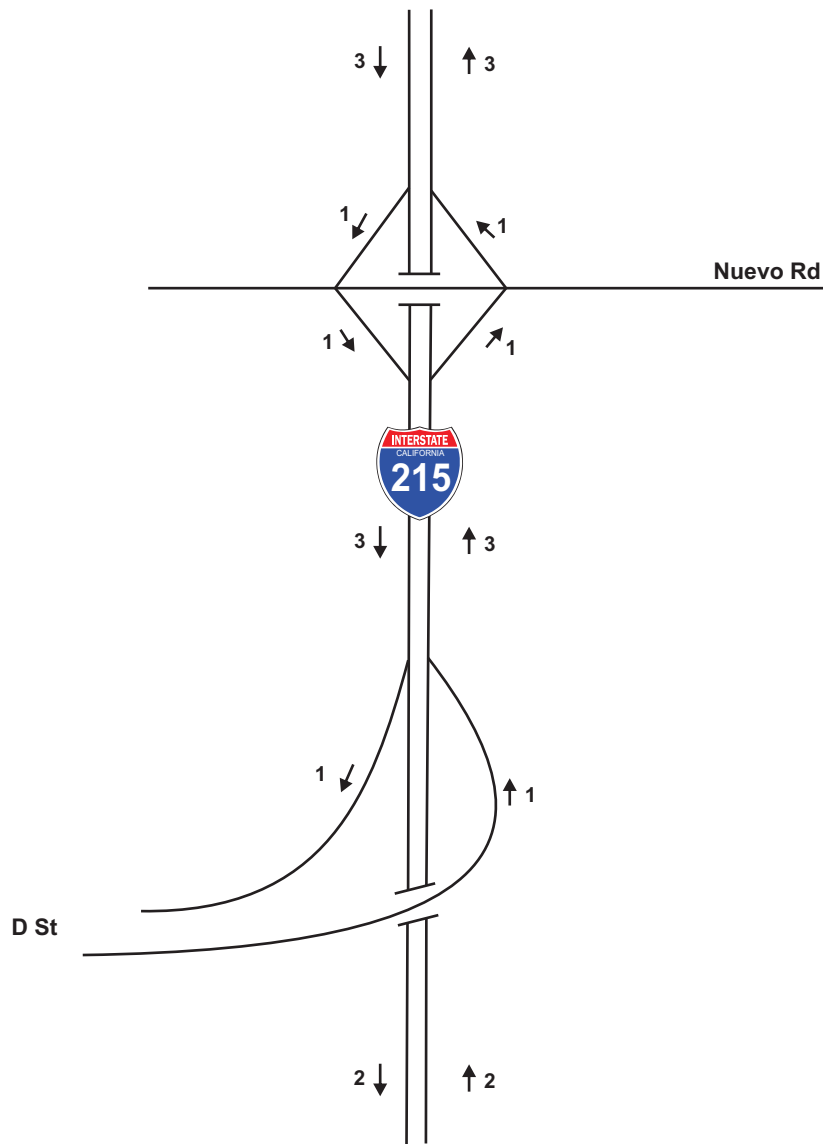

**Existing (2010) Freeway Mainline
Lane Geometry - Interstate 215**

Figure 3-2c

- Legend**
- Direction of Travel
 - X : Number of Lanes (Mixed Flow)



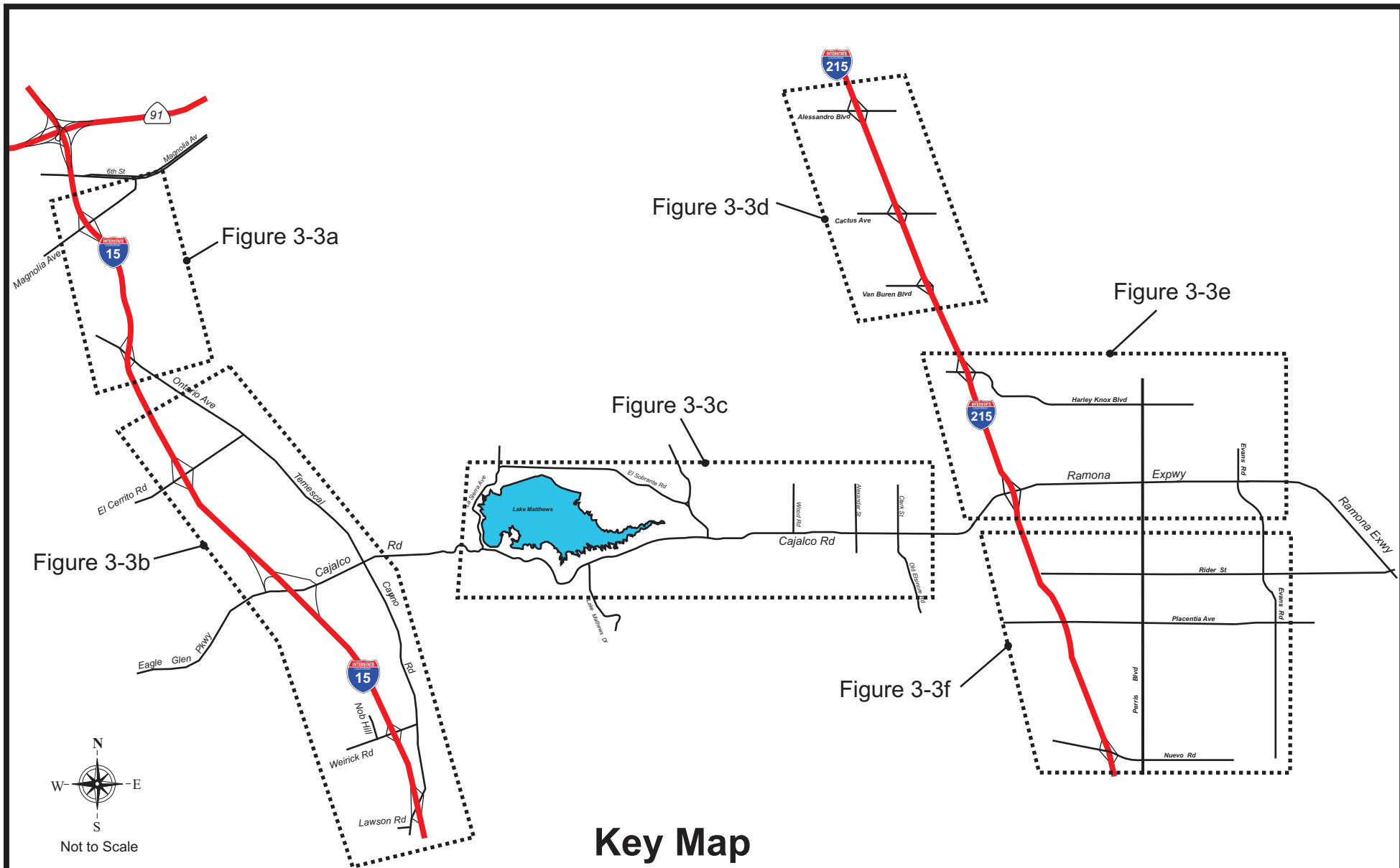

Key Map

Existing (2010) Intersection Lane Geometry

Figure 3-3

Legend:

 Figure Areas



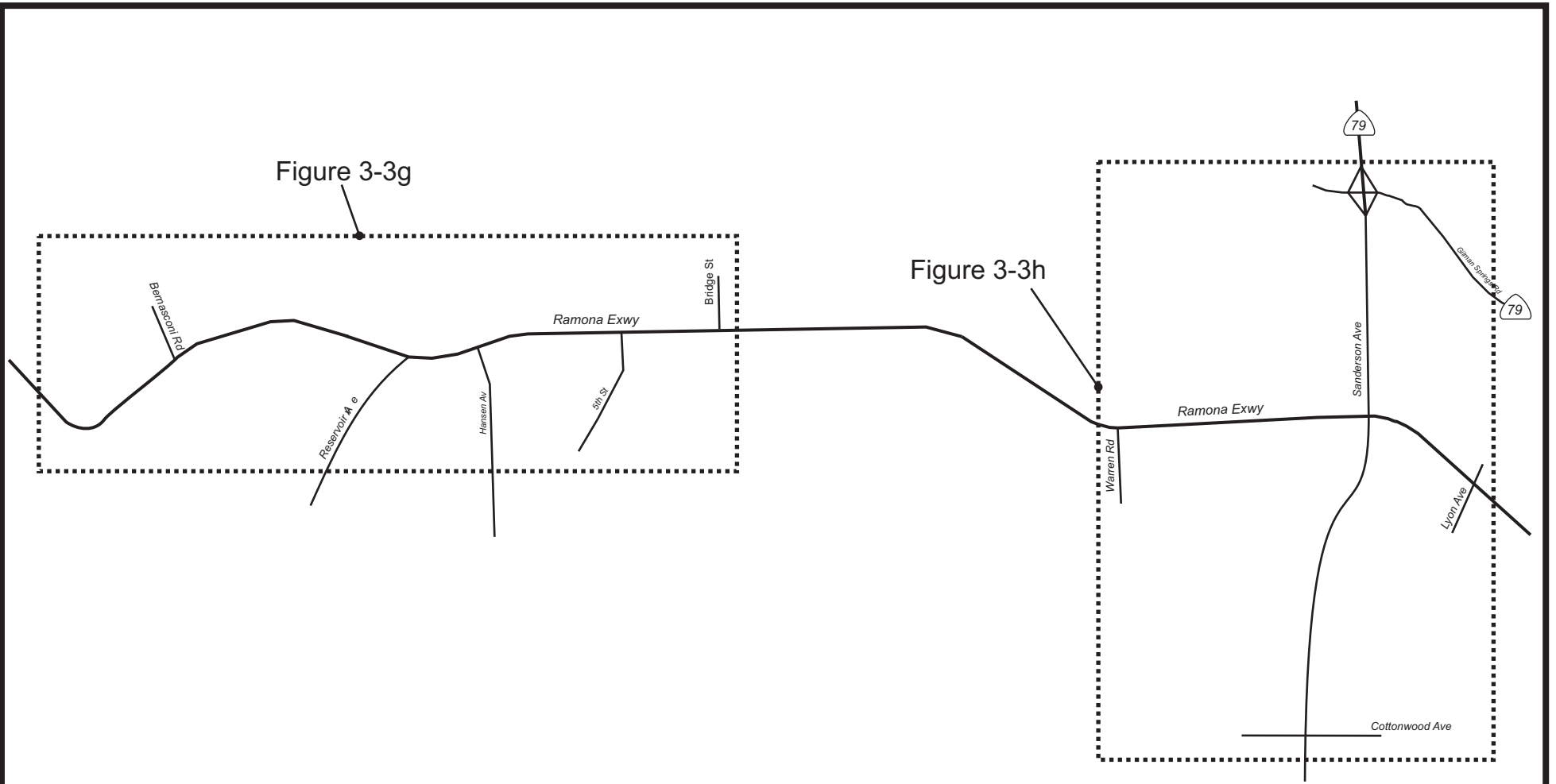

Key Map

Existing (2010) Intersection Lane Geometry

Figure 3-3 (cont.)

Legend:

 Figure Areas



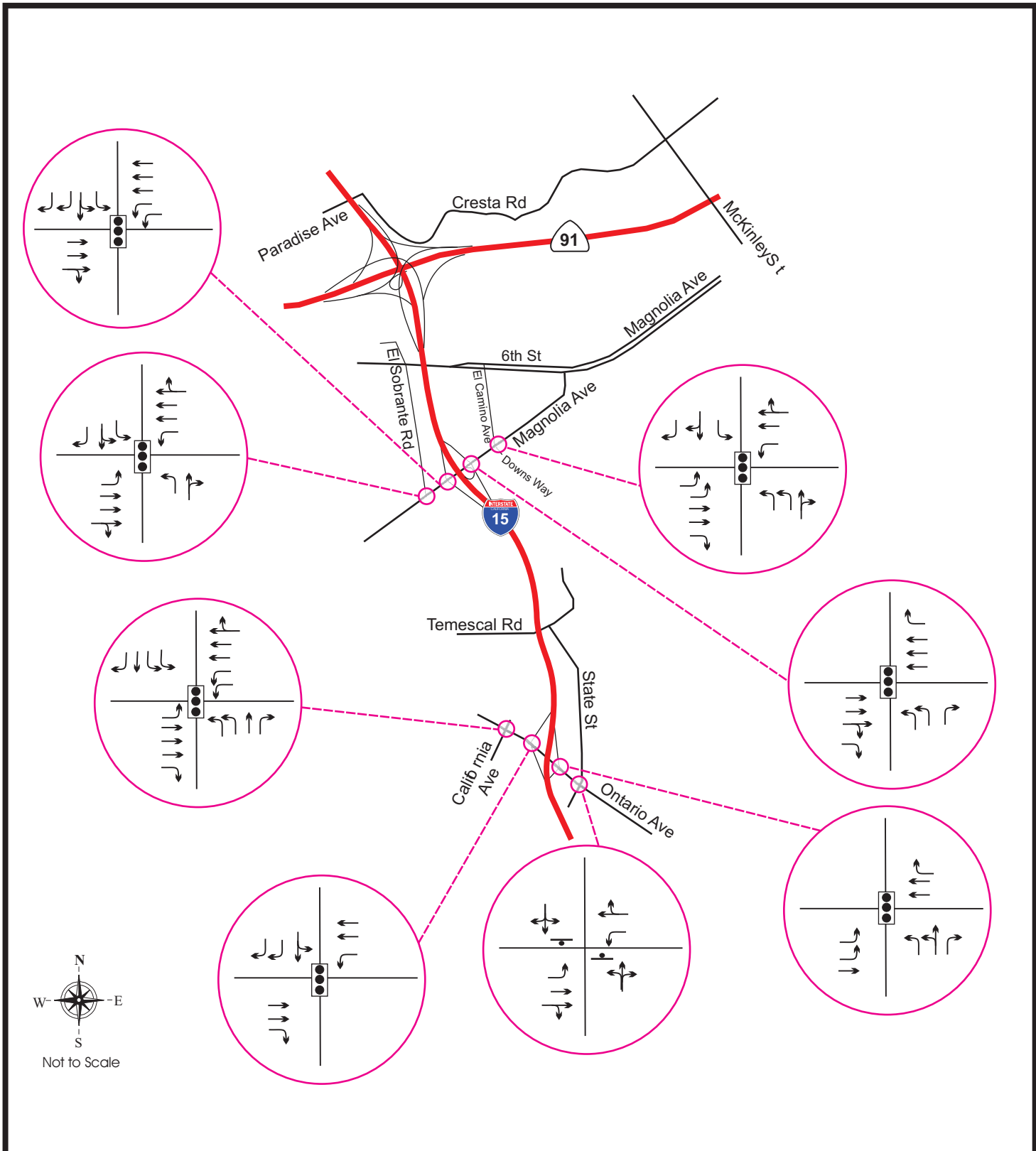

Existing (2010) Intersection Lane Geometry

Figure 3-3a

Legend:

-  Stop Sign
-  Signal
-  Traffic Lane



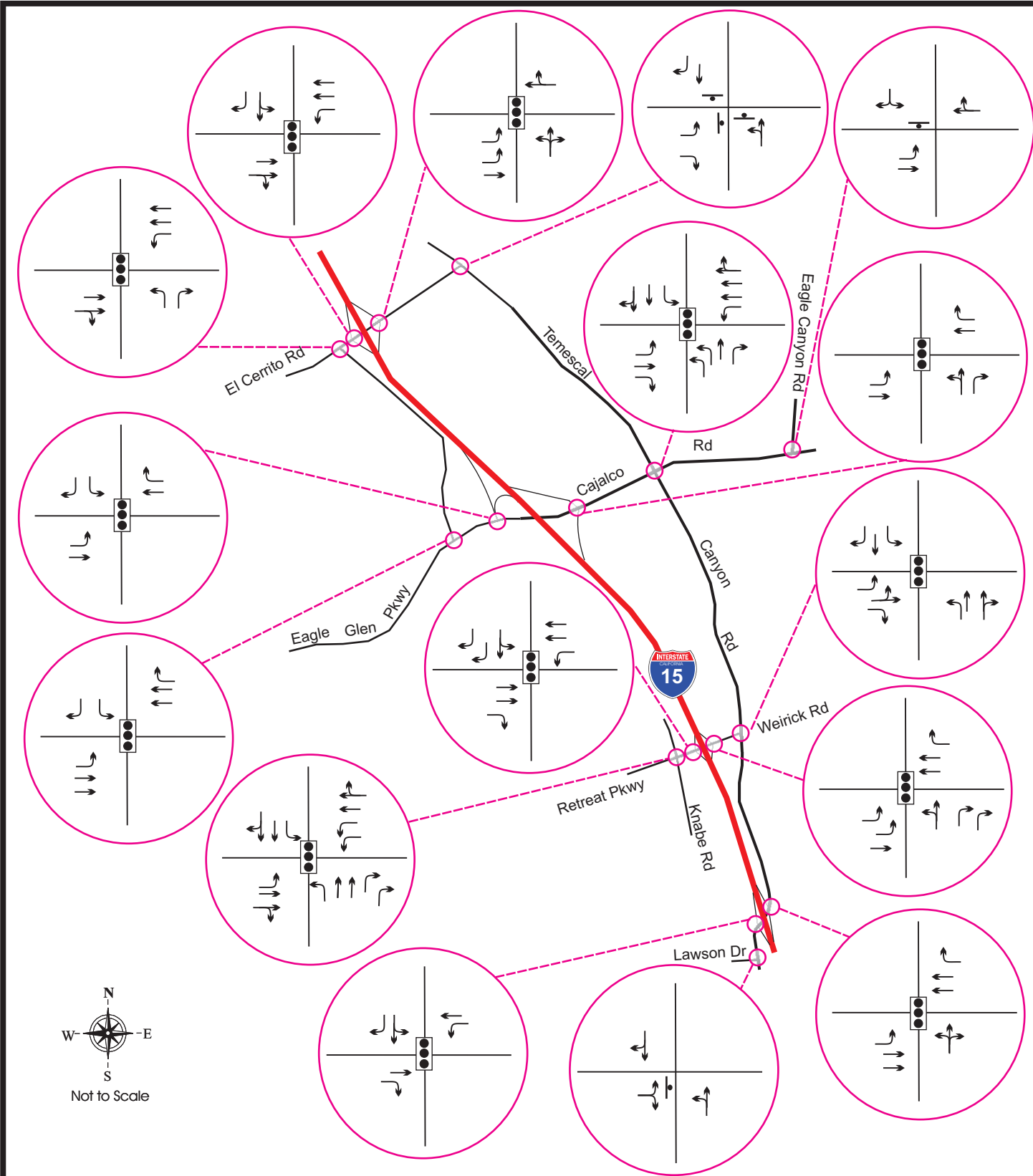

Existing (2010) Intersection Lane Geometry

Figure 3-3b

Legend:

-  Stop Sign
-  Signal
-  Traffic Lane



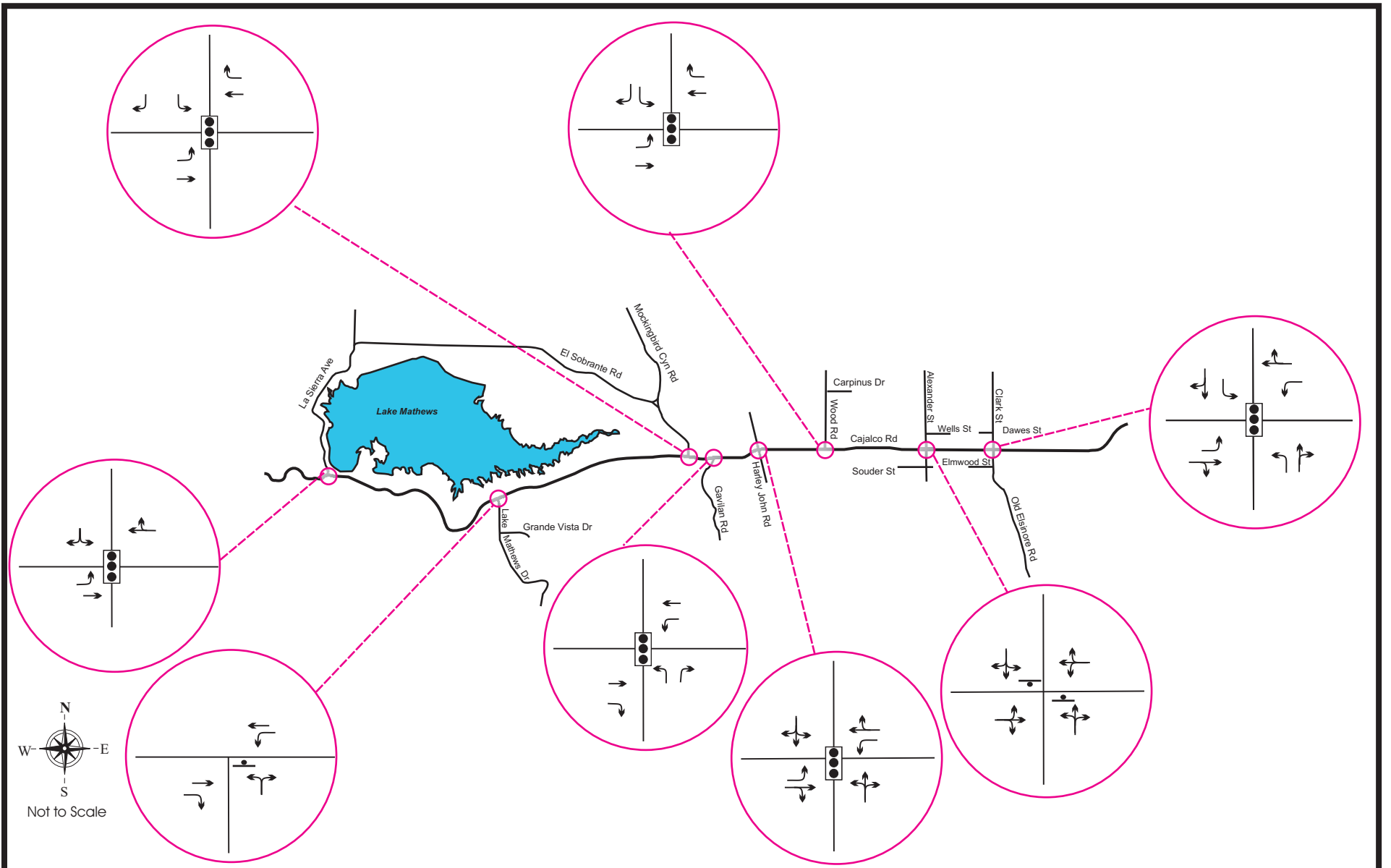



Existing (2010) Intersection Lane Geometry

Figure 3-3c

Legend:

-  Stop Sign
-  Signal
-  Traffic Lane



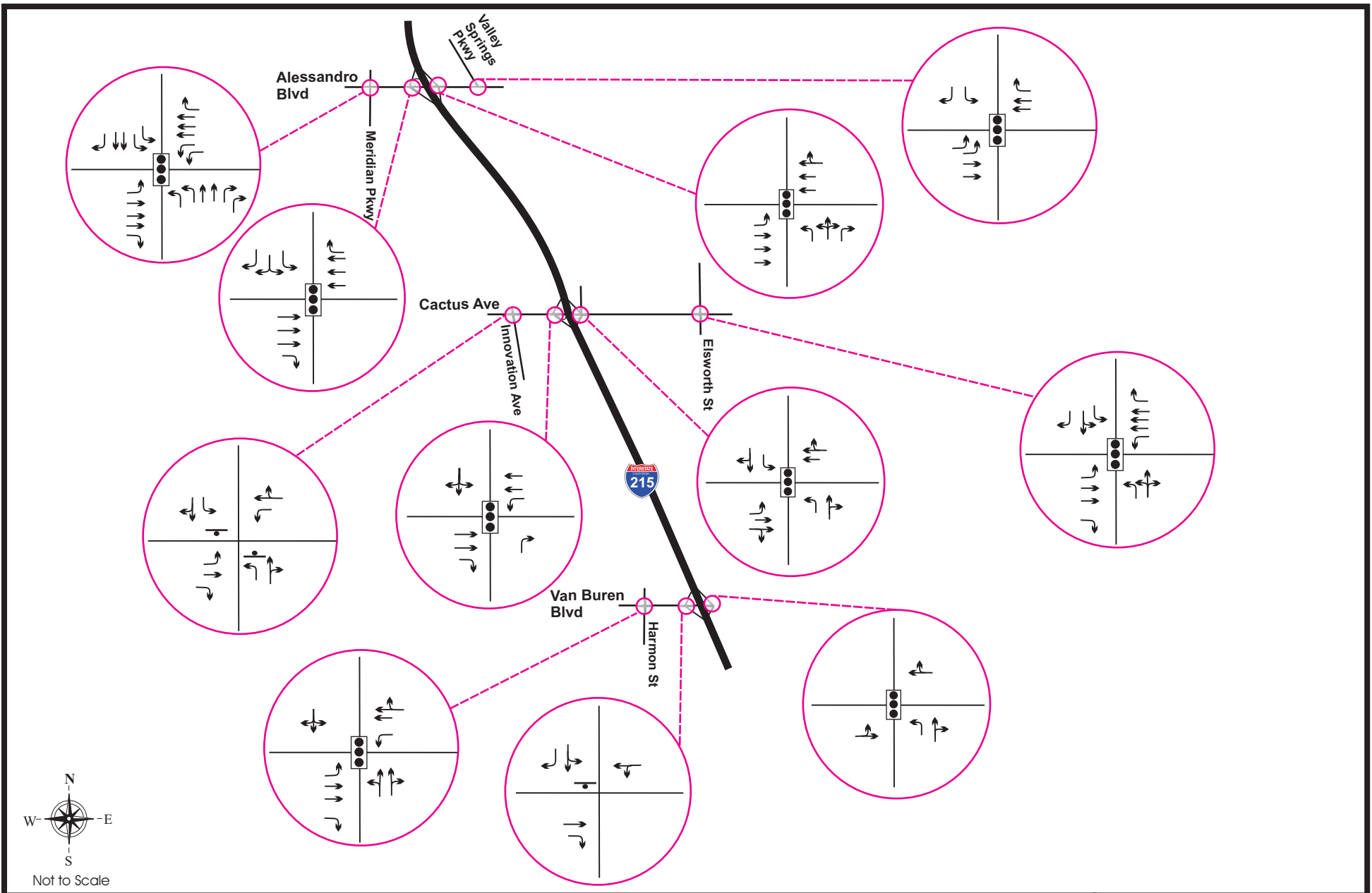



Existing (2010) Intersection Lane Geometry

Figure 3-3d

Legend:

-  Stop Sign
-  Signal
-  Traffic Lane



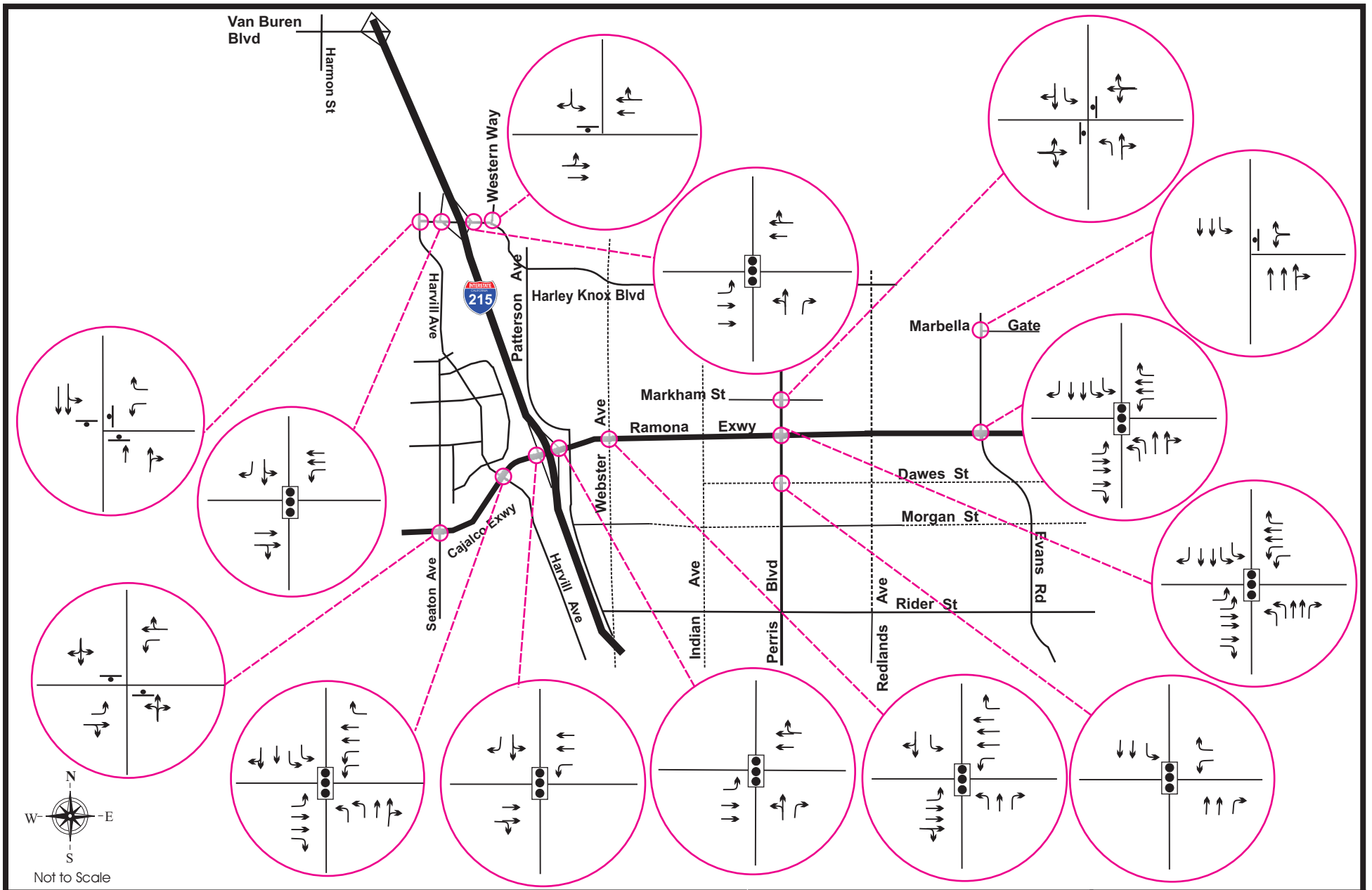



Existing (2010) Intersection Lane Geometry

Figure 3-3e

Legend:

-  Stop Sign
-  Traffic Lane
-  Signal



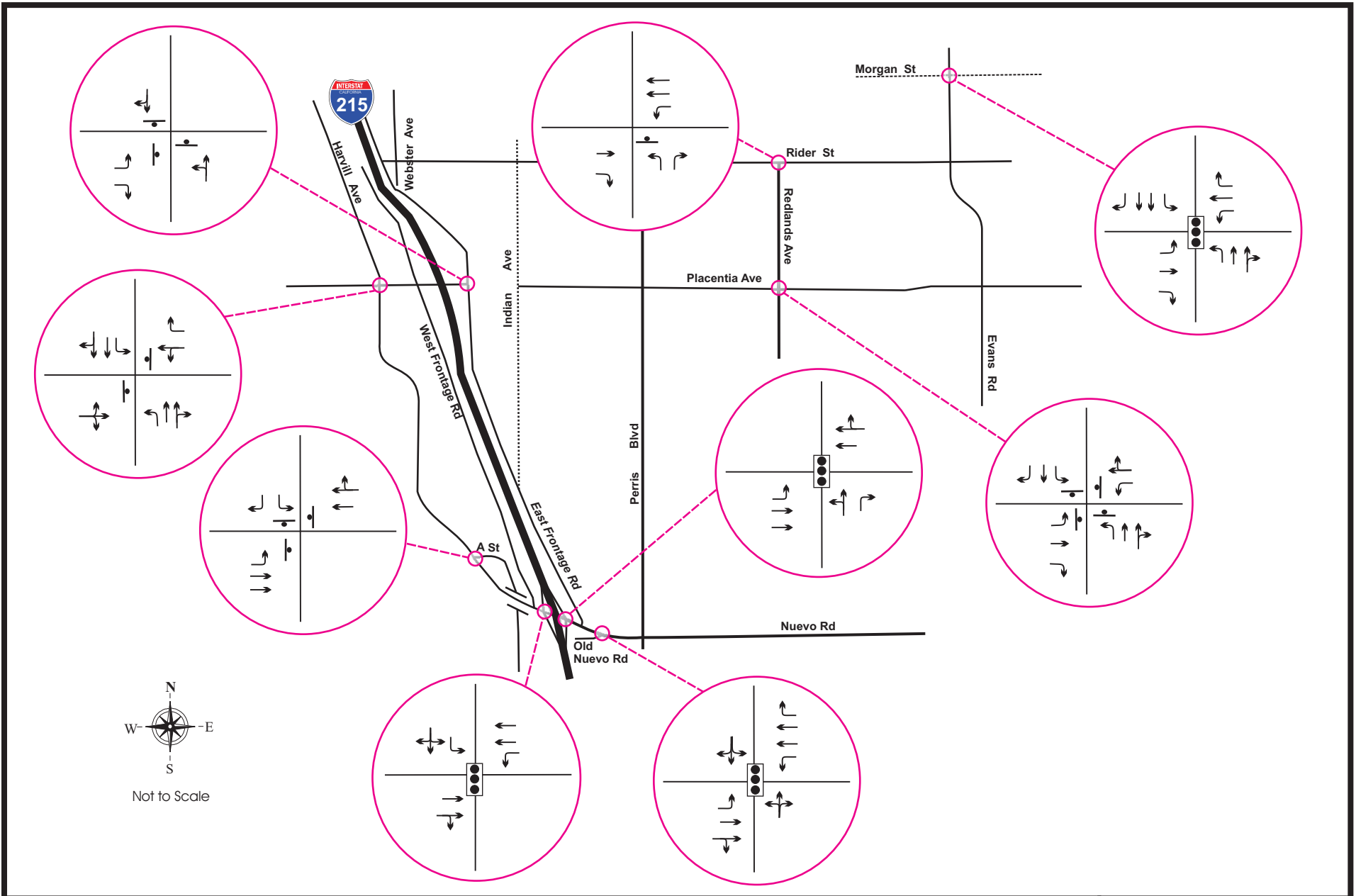



Existing (2010) Intersection Lane Geometry

Figure 3-3f

Legend:

-  Stop Sign
-  Signal
-  Traffic Lane



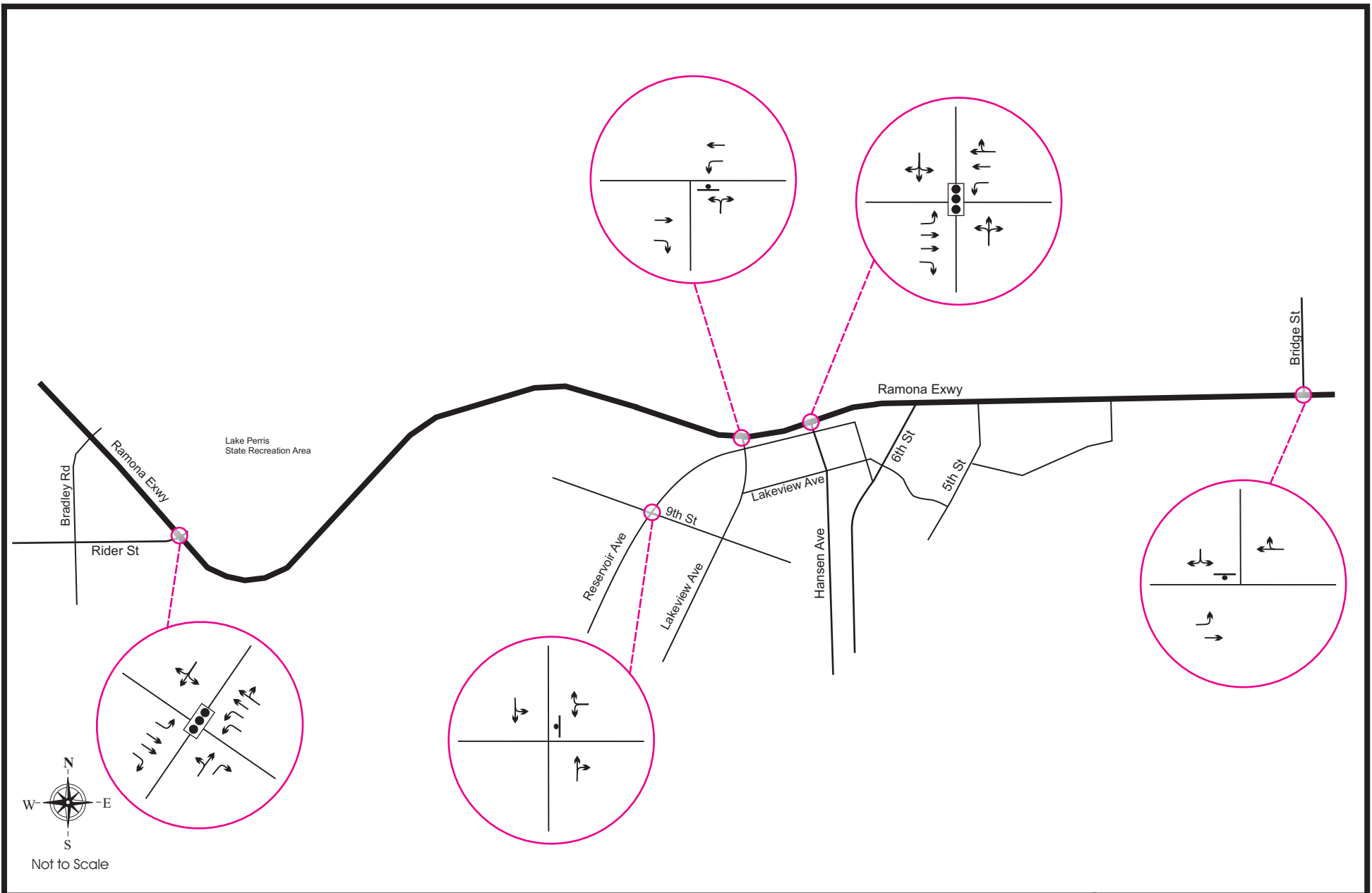



Existing (2010) Intersection Lane Geometry

Figure 3-3g

Legend:

-  Stop Sign
-  Traffic Lane
-  Signal



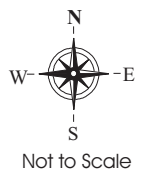
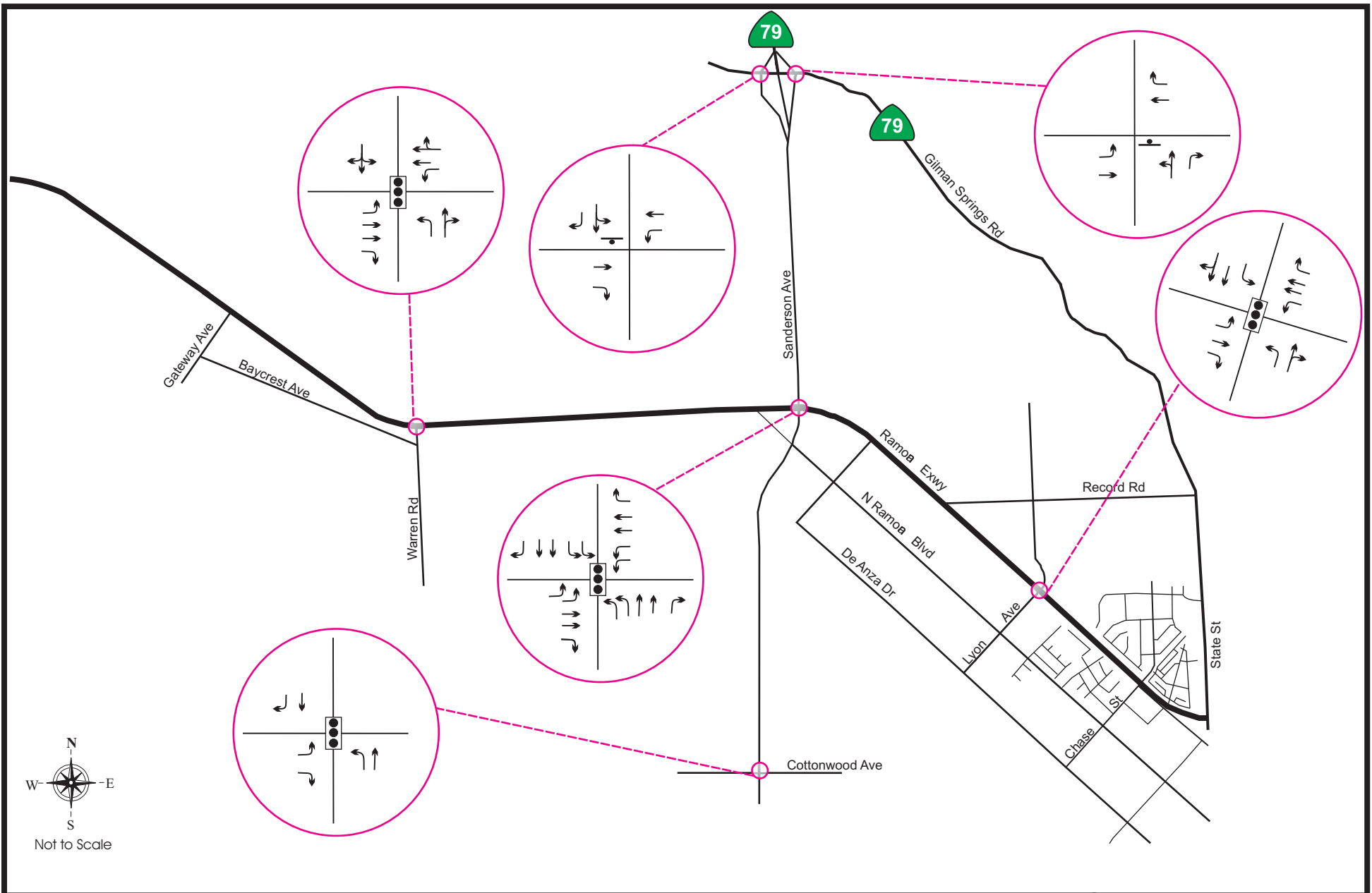

Existing (2010) Intersection Lane Geometry

Figure 3-3h

Legend:

- ⊥ Stop Sign
- ↩ Traffic Lane
- Signal



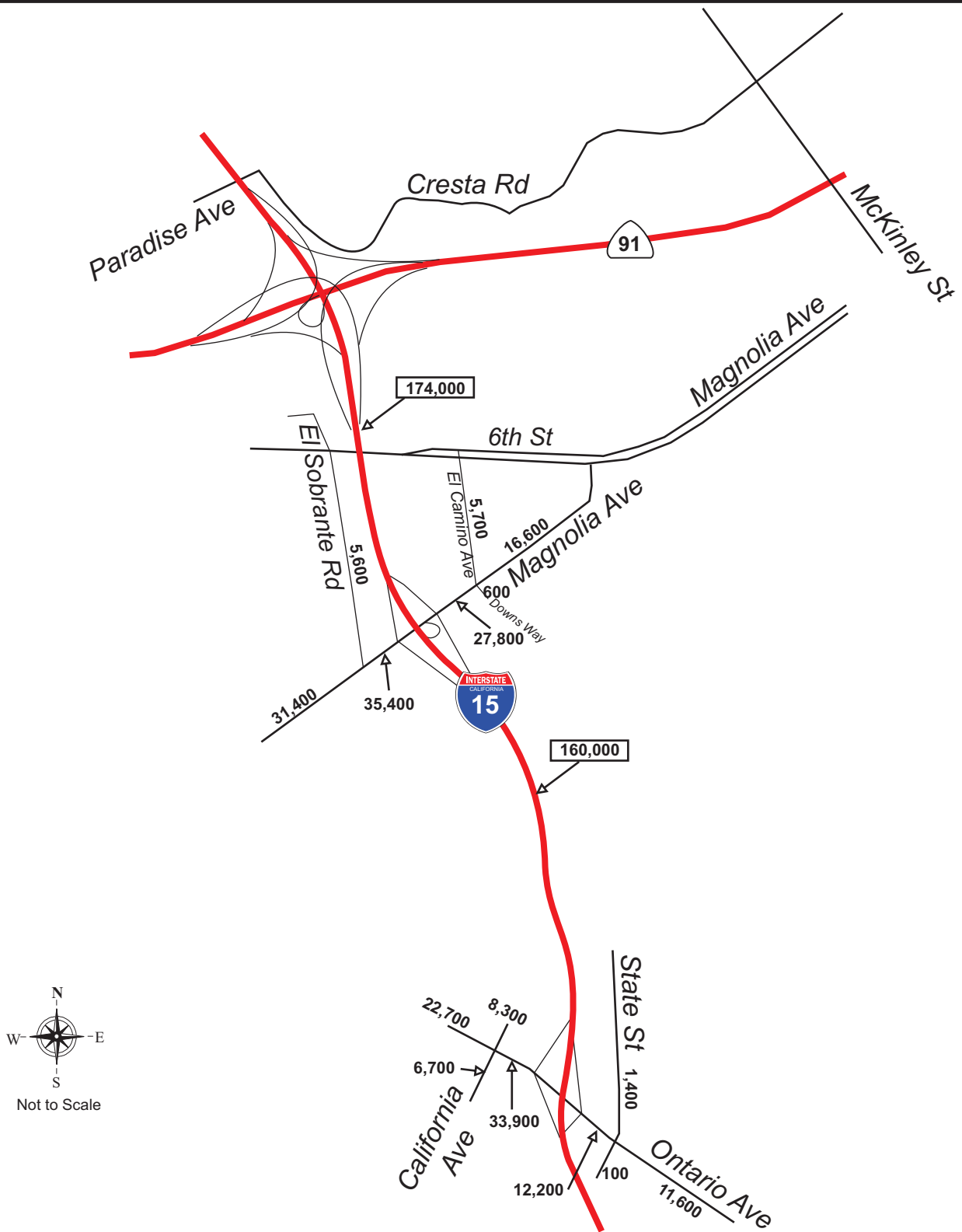

Existing (2010) ADT - Freeway and Street Segments - MCP Area

Figure 3-4a

Legend:

XX,XXX Average Daily Traffic



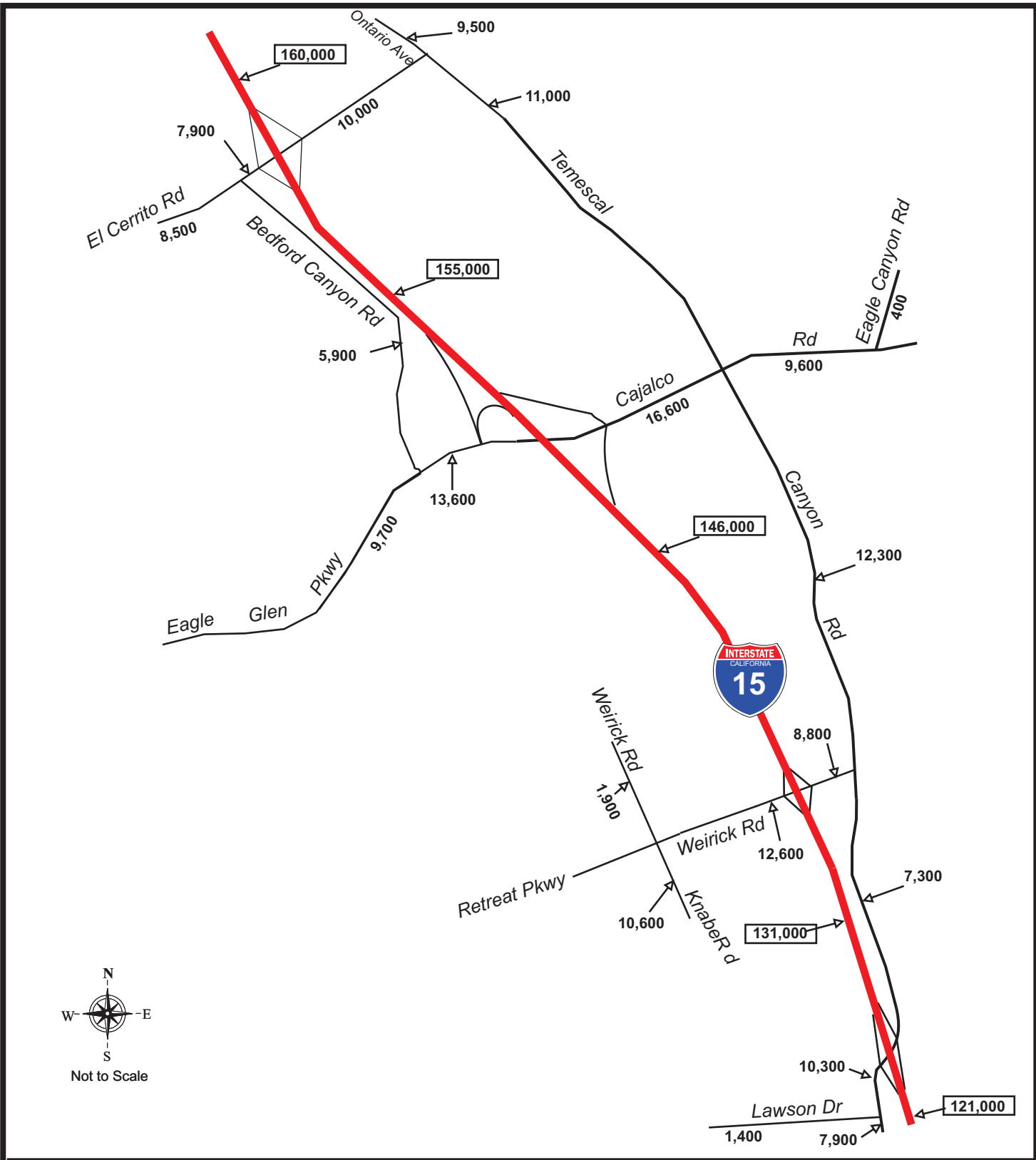

Existing (2010) ADT - Freeway and Street Segments - MCP Area

Figure 3-4b



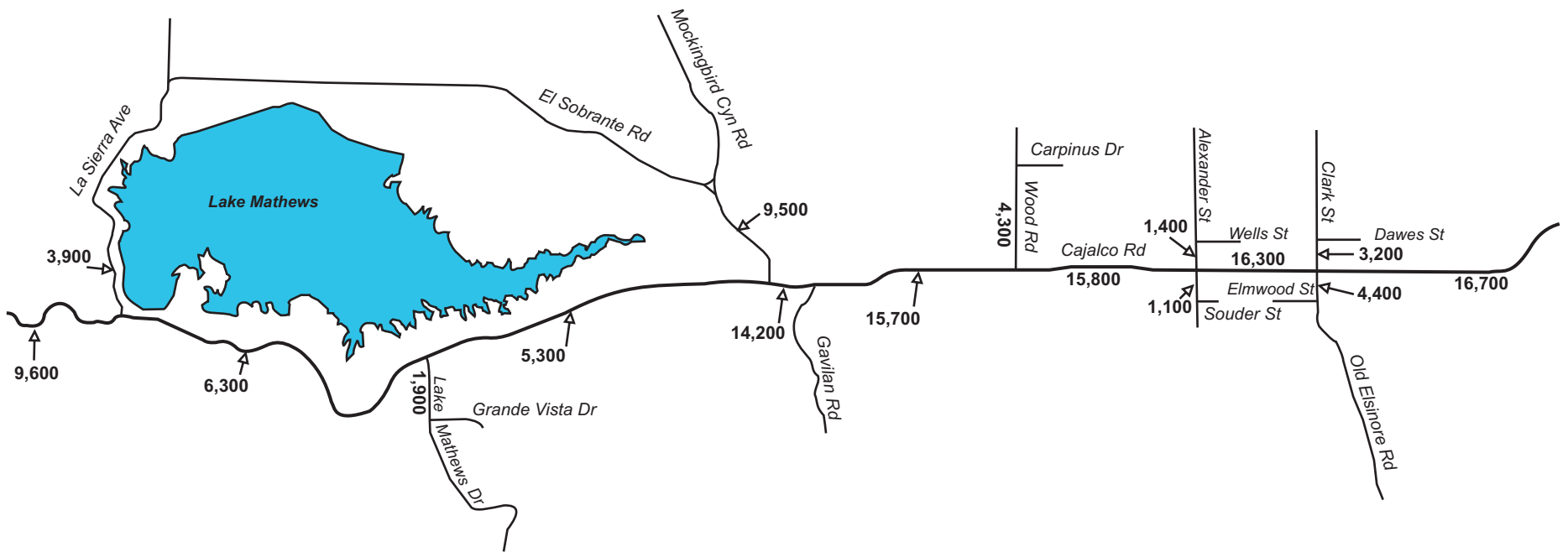

Existing (2010) ADT - Freeway and Street Segments - MCP Area

Figure 3-4c

Legend:

XX,XXX Average Daily Traffic



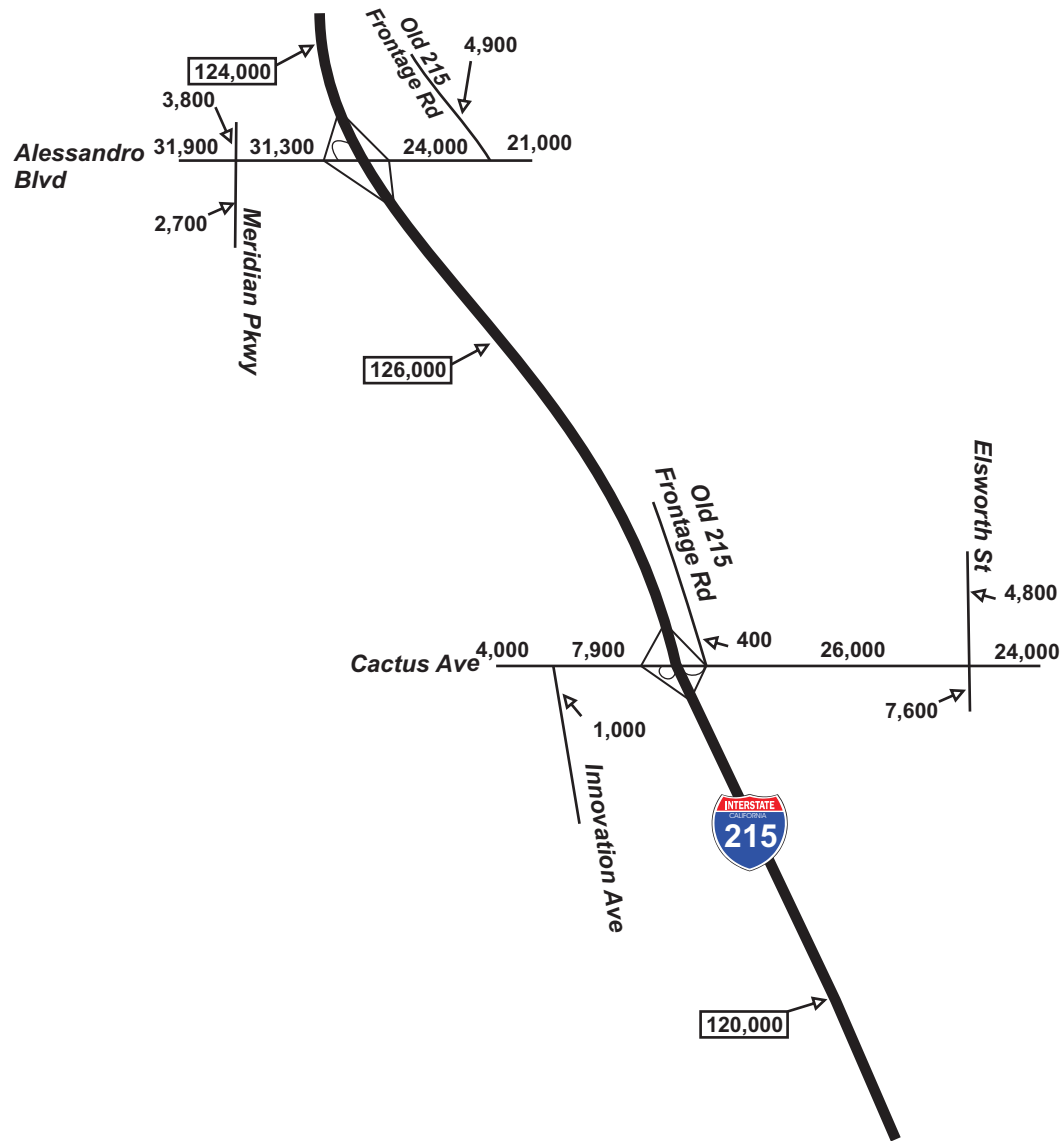

Not to Scale

Existing (2010) ADT - Freeway and Street Segments - MCP Area

Figure 3-4d

Legend:

XX,XXX Average Daily Traffic



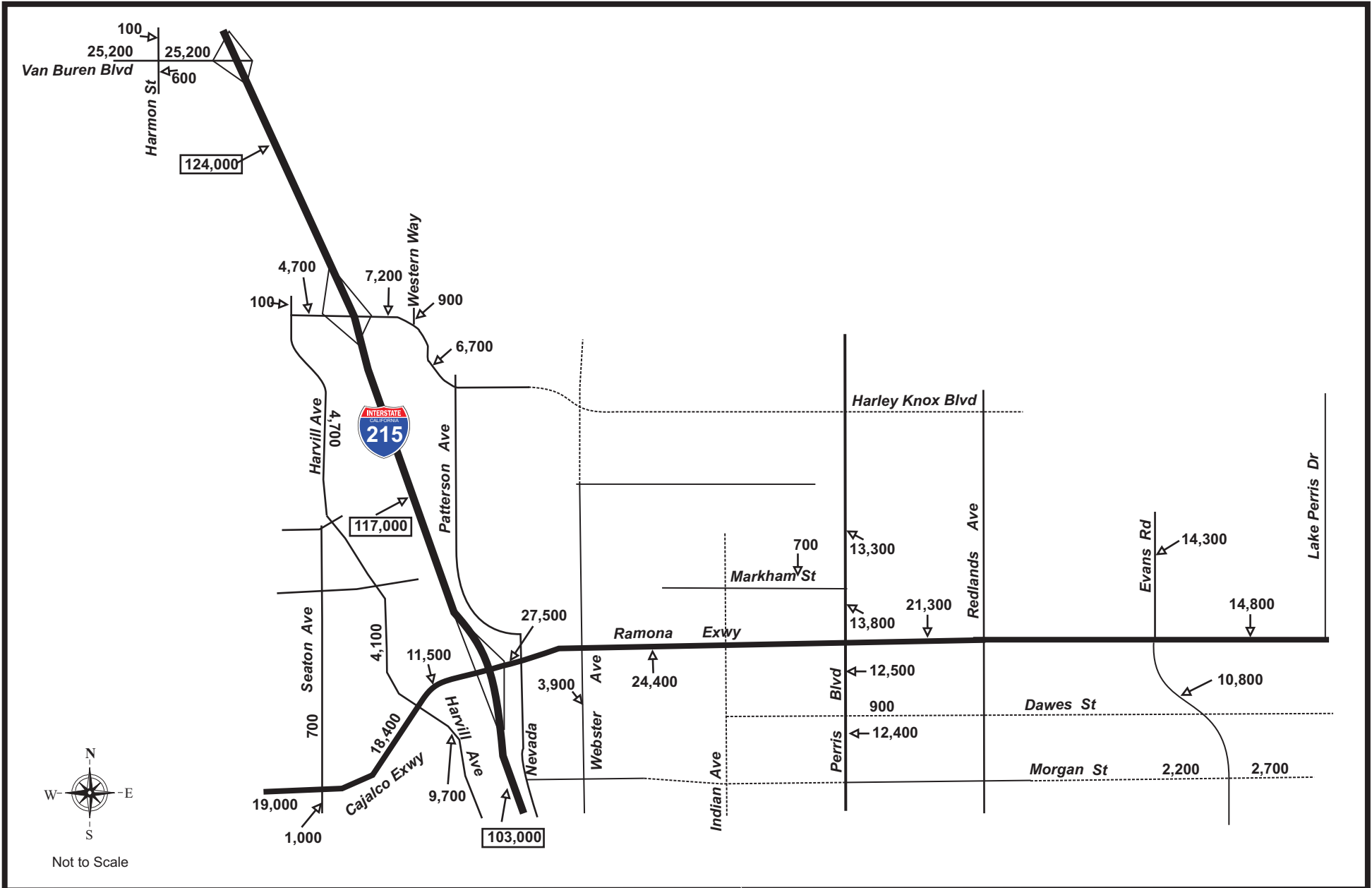

Existing (2010) ADT - Freeway and Street Segments - MCP Area

Figure 3-4e

Legend:

XX,XXX Average Daily Traffic



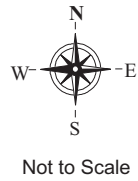
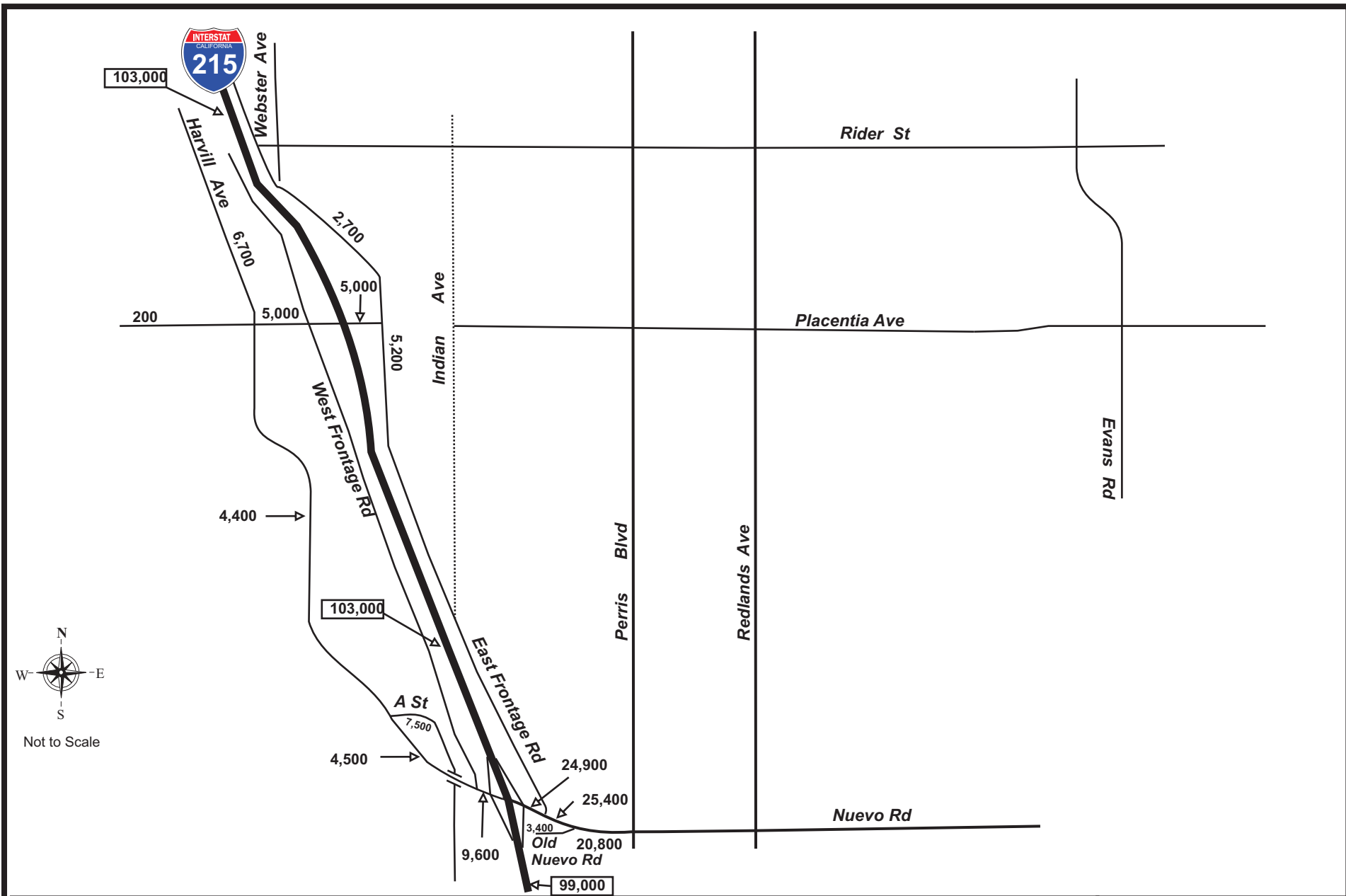

Existing (2010) ADT - Freeway and Street Segments - MCP Area

Figure 3-4f

Legend:

XX,XXX Average Daily Traffic



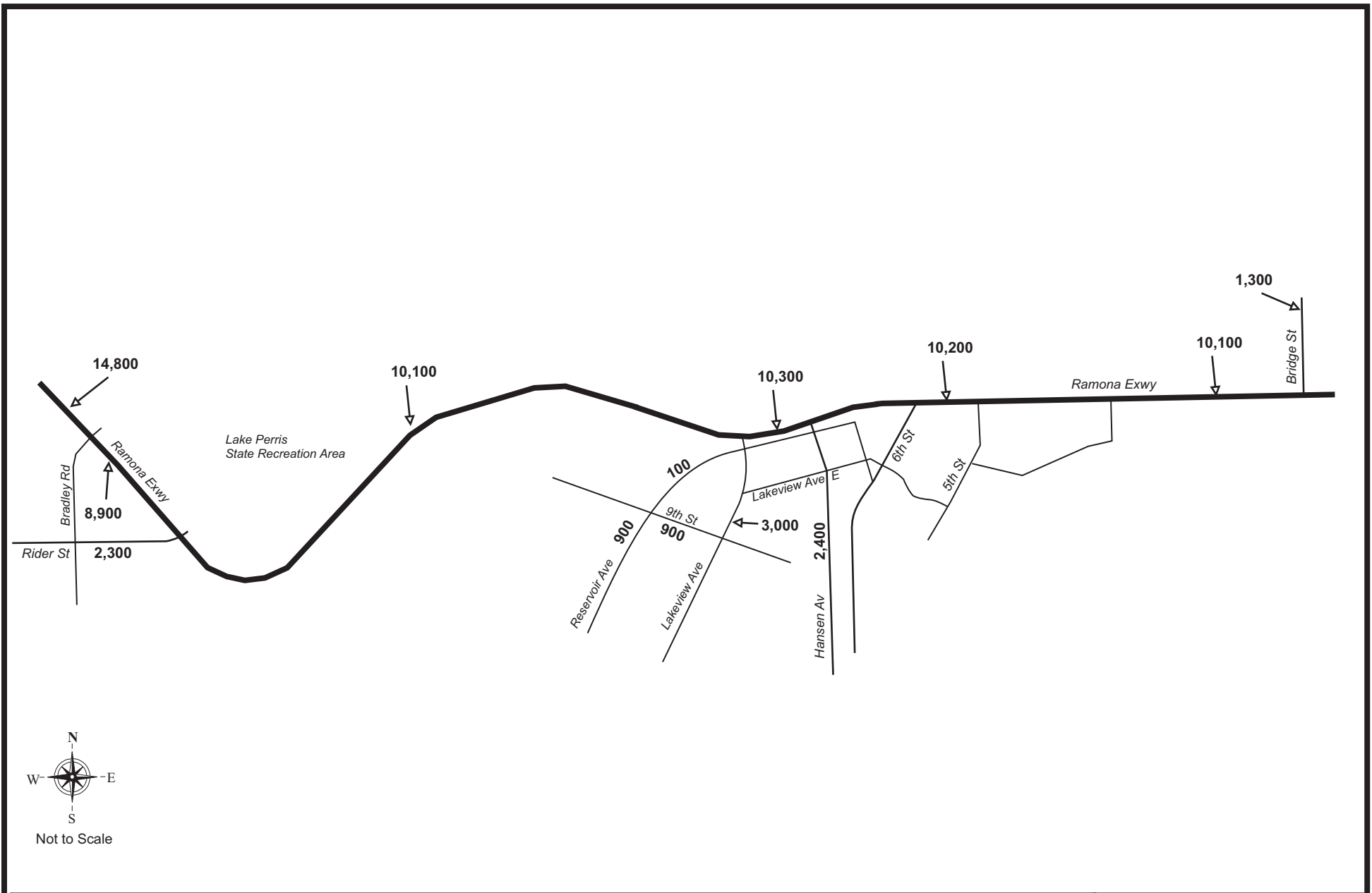

Existing (2010) ADT - Freeway and Street Segments - MCP Area

Figure 3-4g

Legend:

XX,XXX Average Daily Traffic



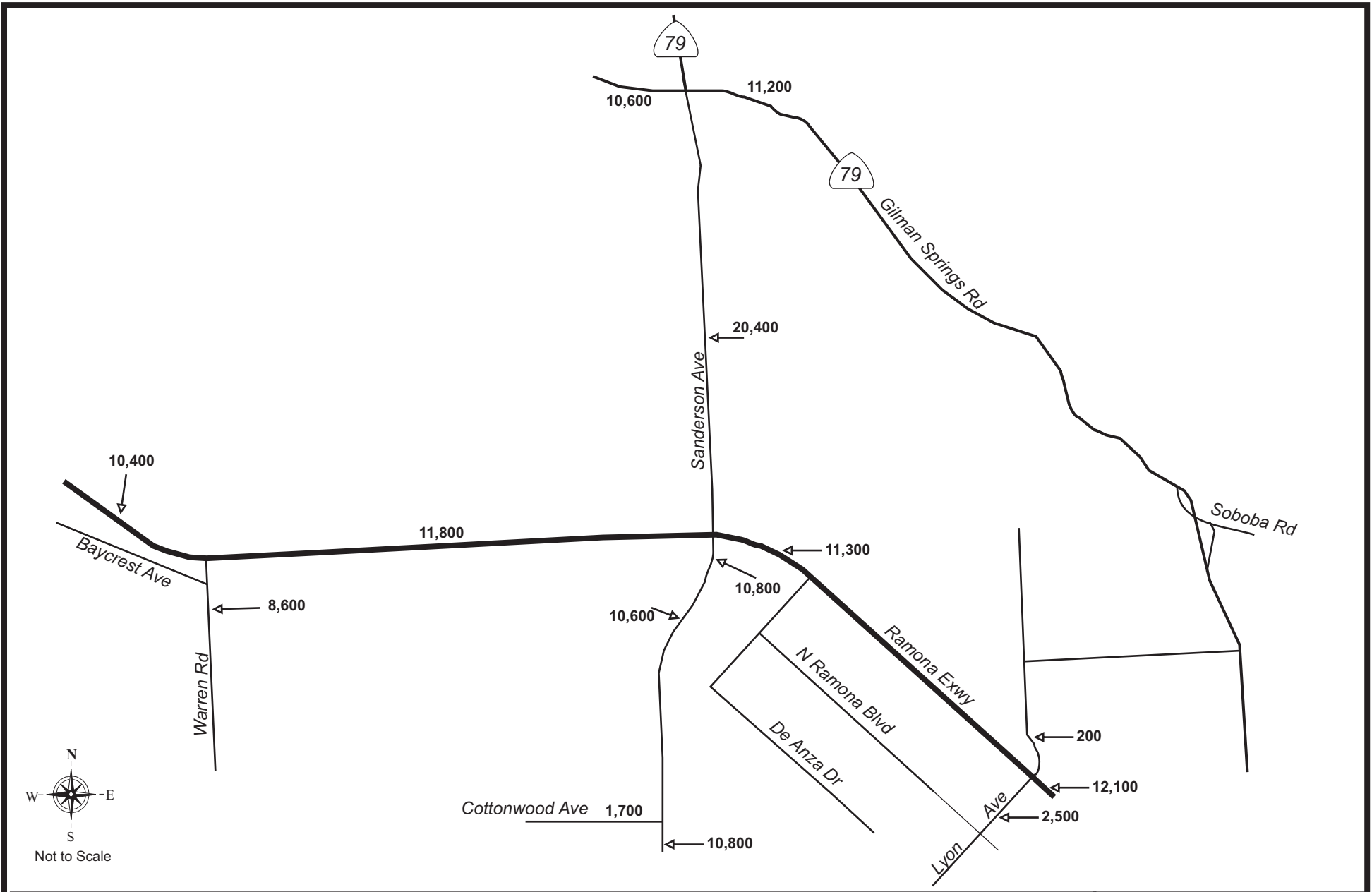

Existing (2010) ADT - Freeway and Street Segments - MCP Area

Figure 3-4h

Legend:

XX,XXX Average Daily Traffic



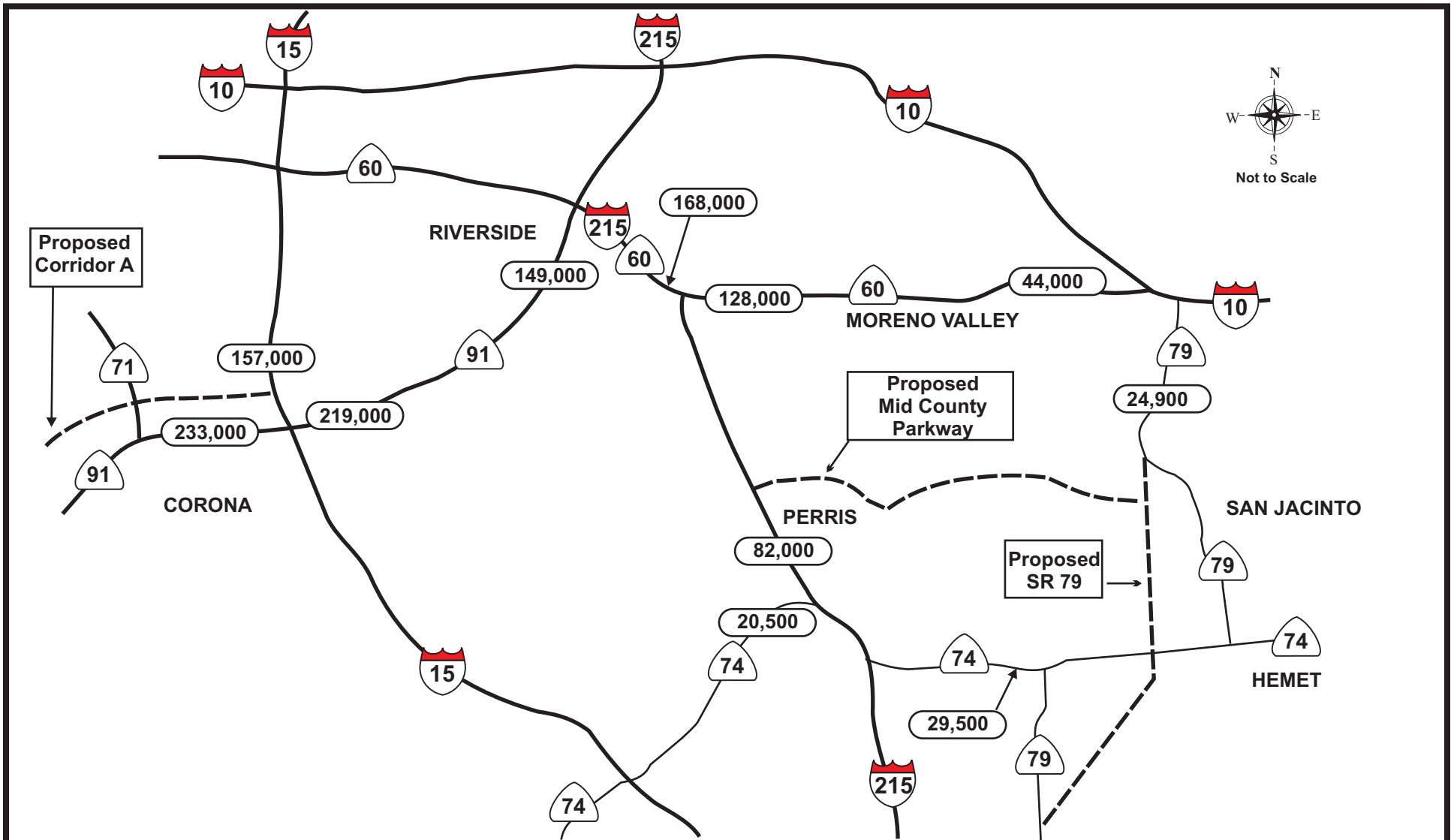

Existing (2010) ADT Freeway and Street Segments - Outside MCP Area

Figure 3-5

Legend

- Existing Limited Access Roadway
- Proposed Limited Access Roadway
- Existing Arterial Roadway
- (XXX,XXX) Average Daily Traffic



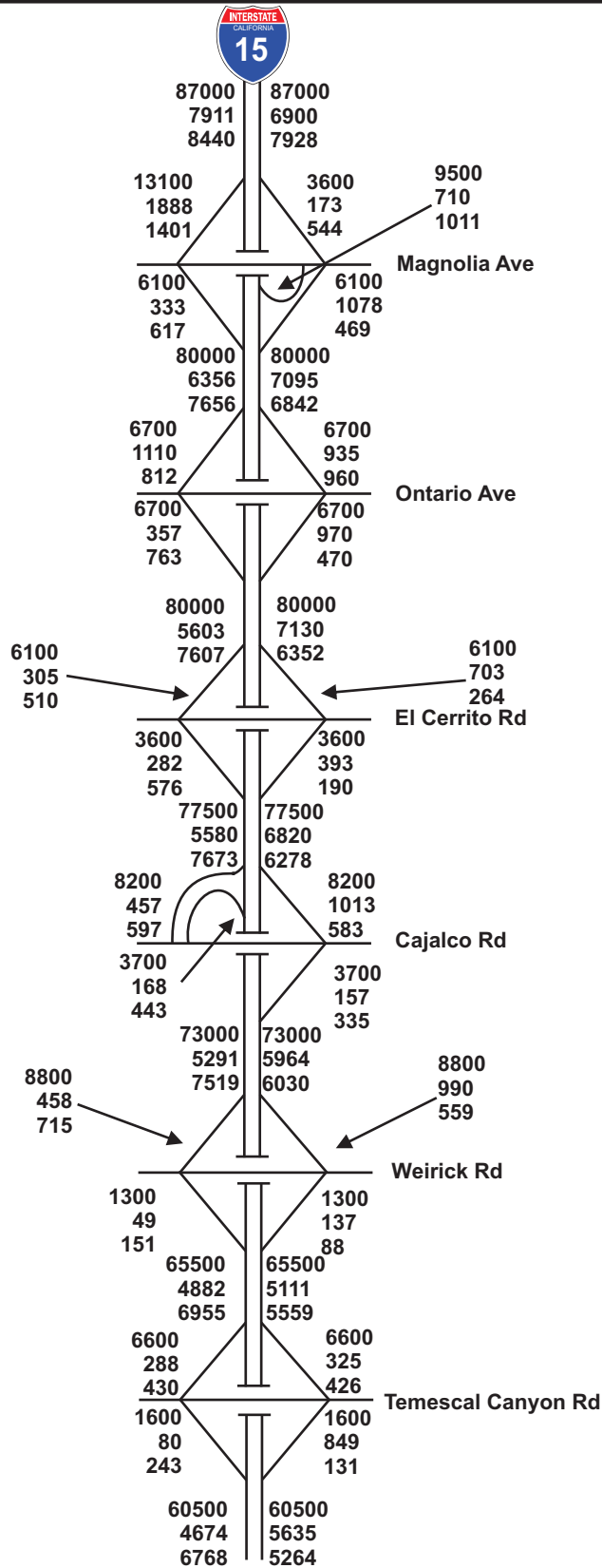

Existing (2010) Freeway and Ramp Traffic - Interstate 15

Figure 3-6

Legend

- XXXXXX ADT
- XXXX AM Peak Hour
- XXXX PM Peak Hour



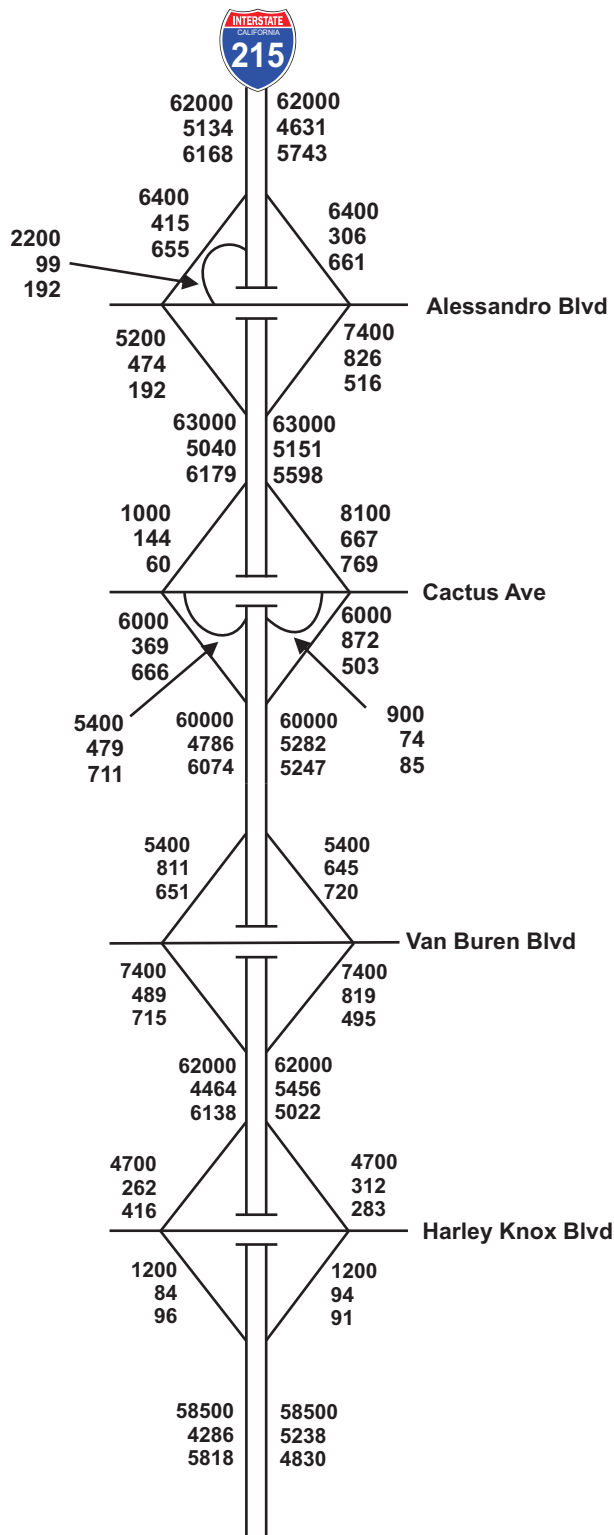

Not to Scale

Existing (2010) Freeway and Ramp Traffic - Interstate 215

Figure 3-7a

Legend

- XXXXX ADT
- XXXX AM Peak Hour
- XXXX PM Peak Hour



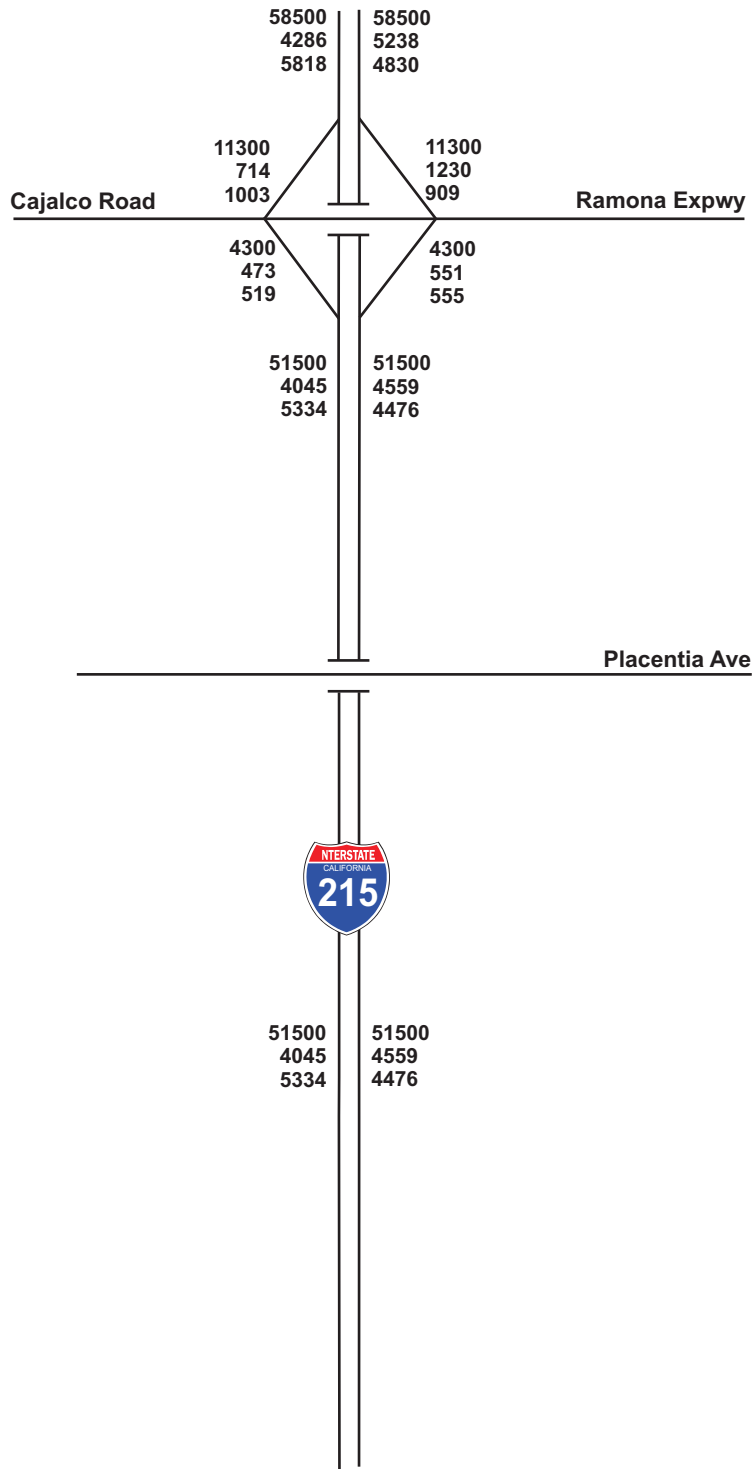

Not to Scale

Existing (2010) Freeway and Ramp Traffic - Interstate 215

Figure 3-7b

Legend

- XXXXX ADT
- XXXX AM Peak Hour
- XXXX PM Peak Hour



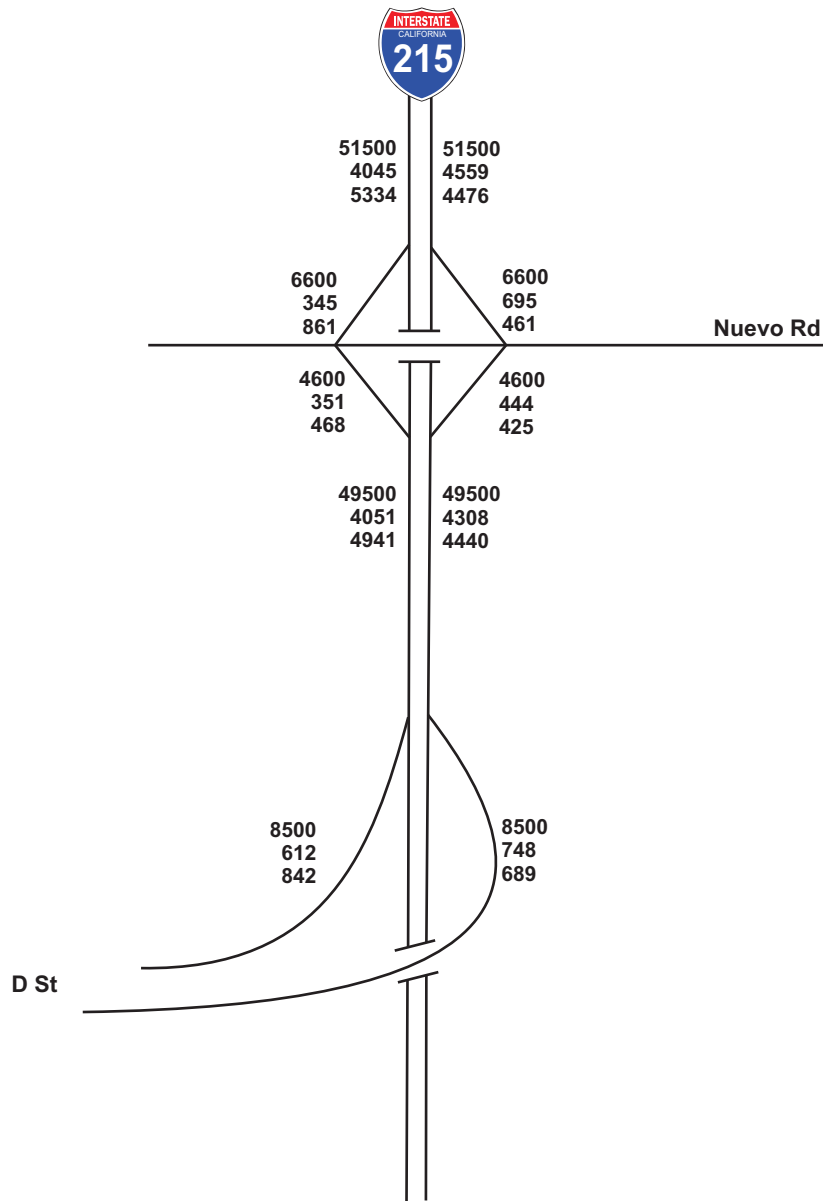

**Existing (2010) Freeway and Ramp Traffic -
Interstate 215**

Figure 3-7c

Legend

- XXXXX** ADT
- XXXX** AM Peak Hour
- XXXX** PM Peak Hour



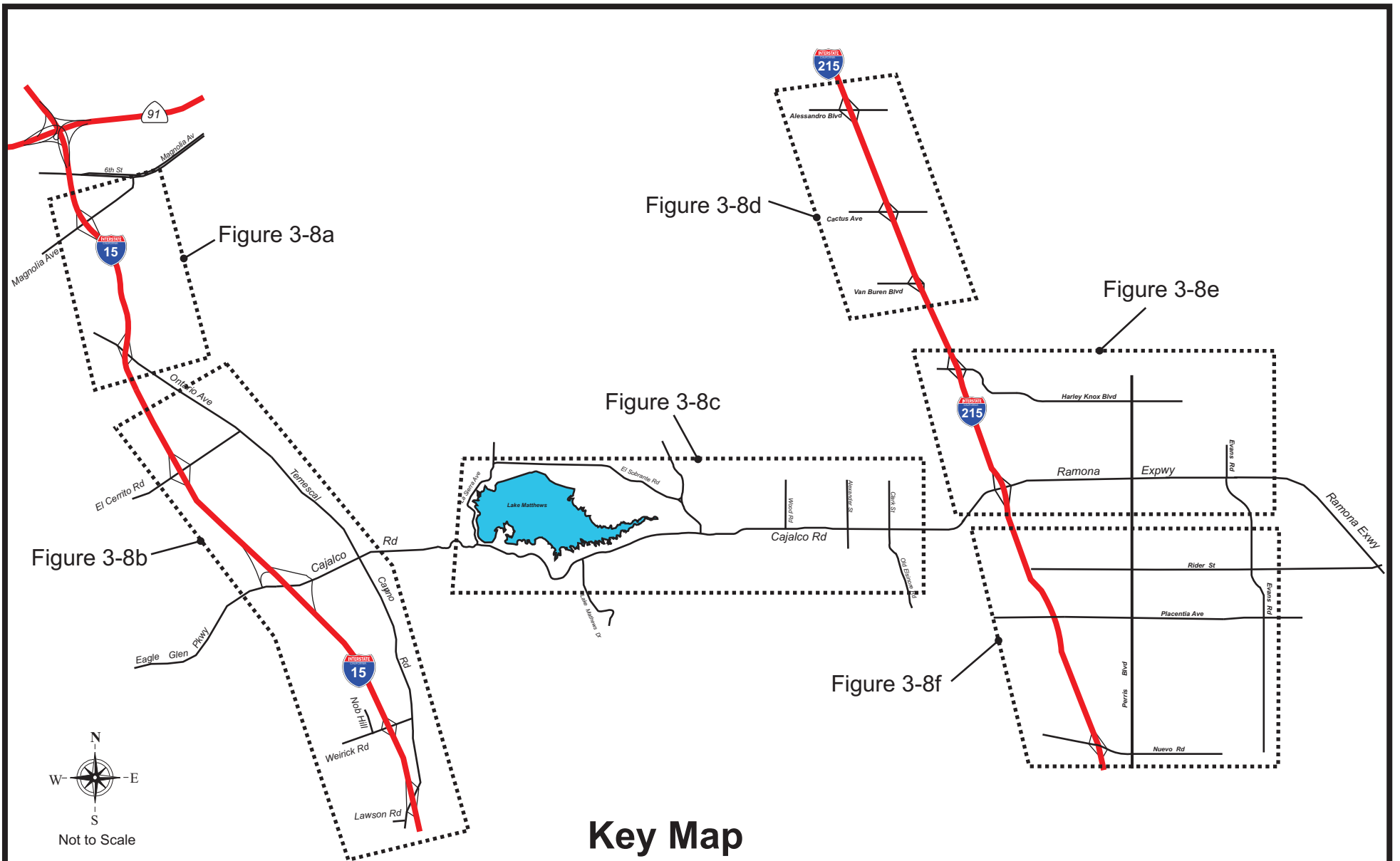

Existing (2010) AM/PM Peak Hour Traffic - Intersections

Figure 3-8

Legend:

 Figure Areas



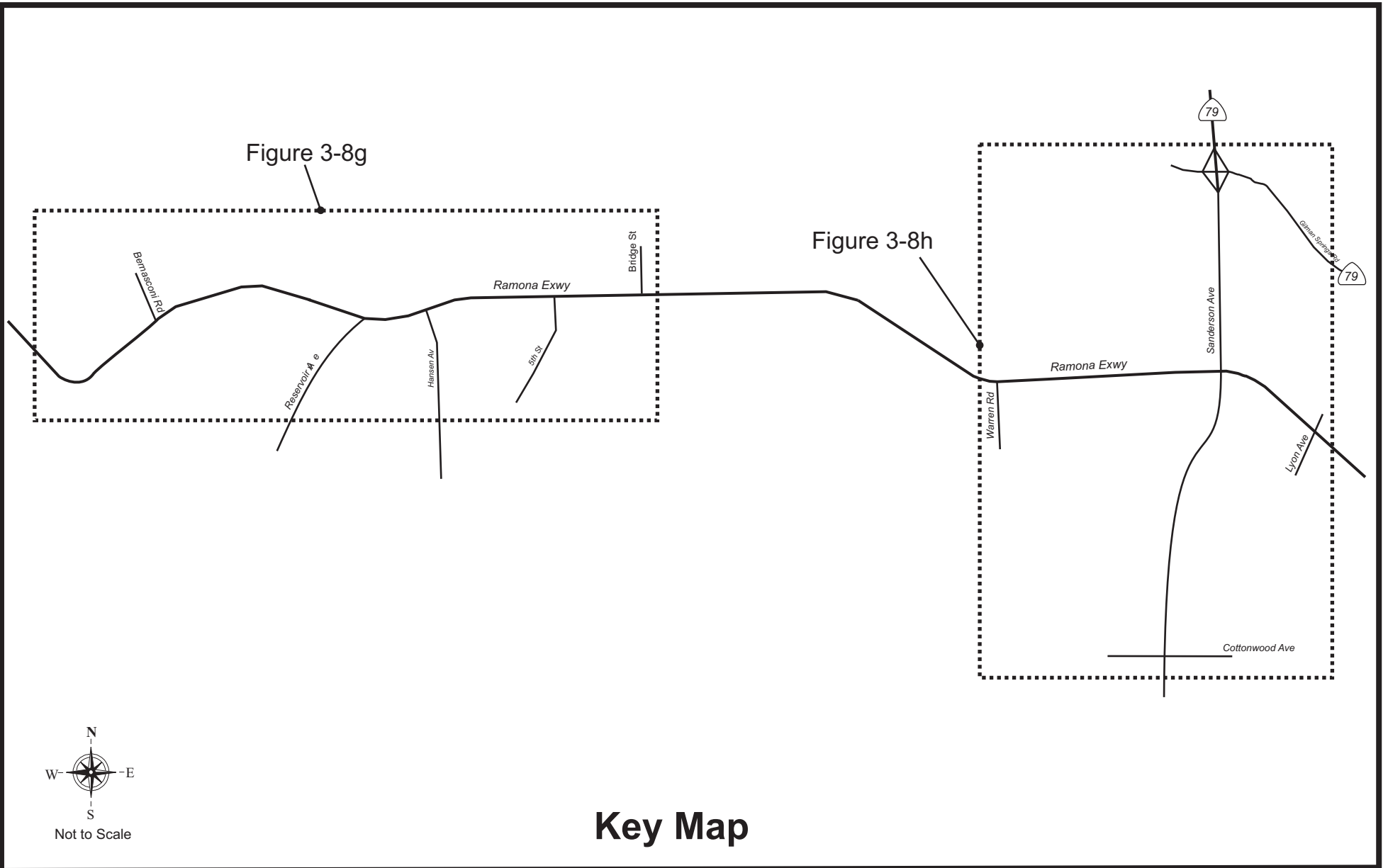

Key Map

Existing (2010) AM/PM Peak Hour Traffic - Intersections

Figure 3-8 (cont.)

Legend:

 Figure Areas



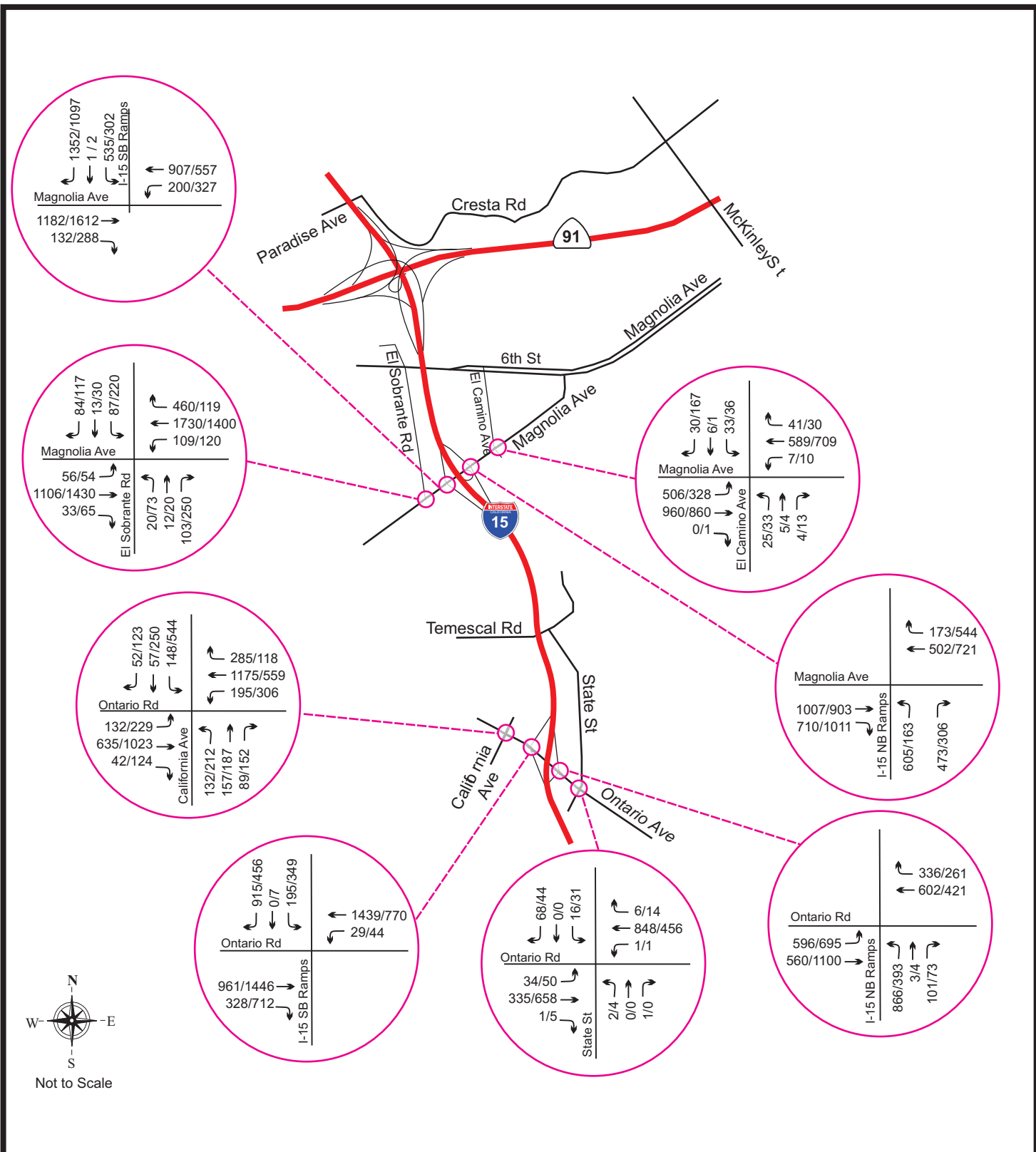

Existing (2010) AM/PM Peak Hour Traffic Intersections

Figure 3-8a

← XXX/XXX Peak Hour Traffic AM/PM



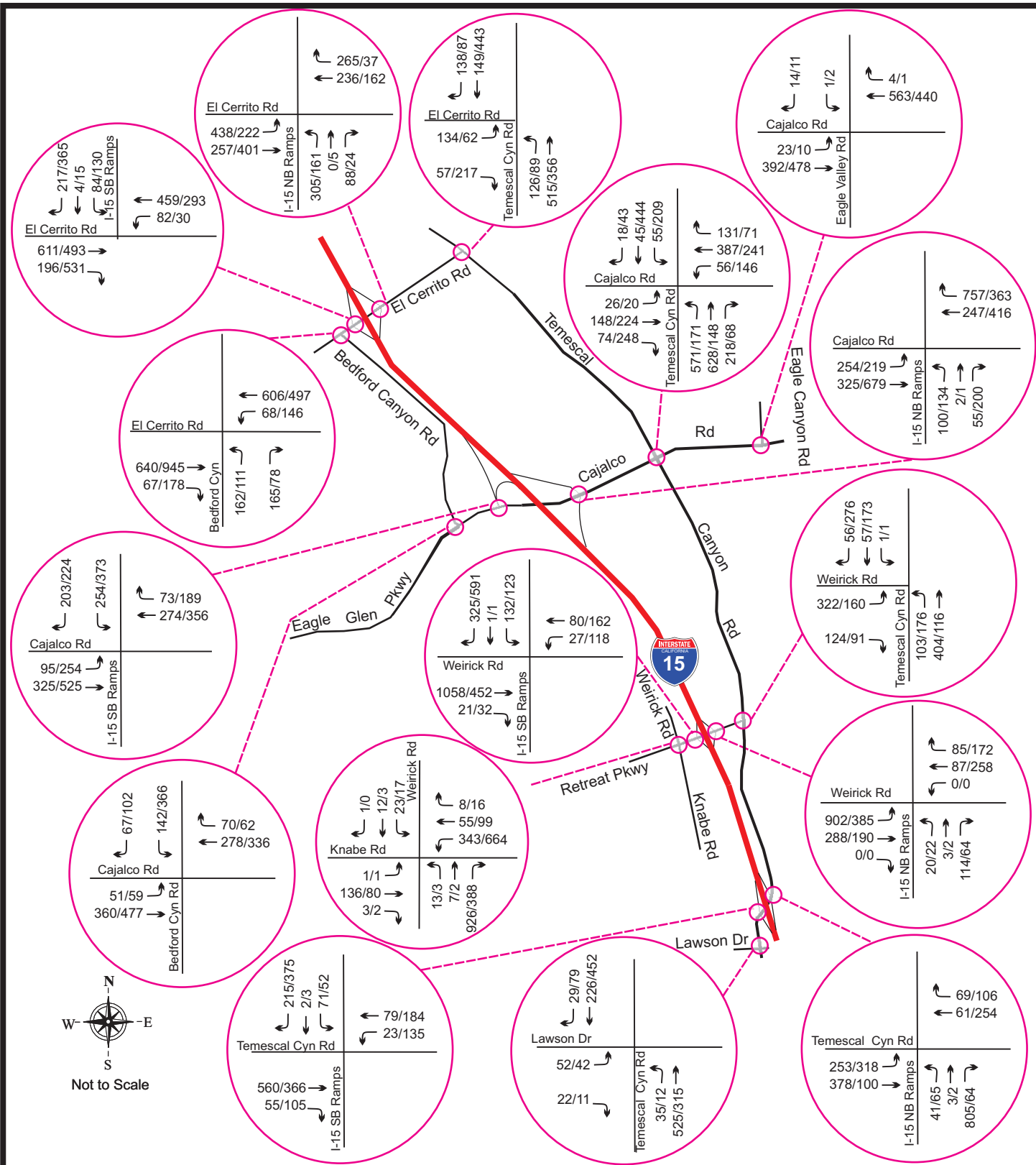

Existing (2010) AM/PM Peak Hour Traffic Intersections

Figure 3-8b

XXX/XXX Peak Hour Traffic AM/PM



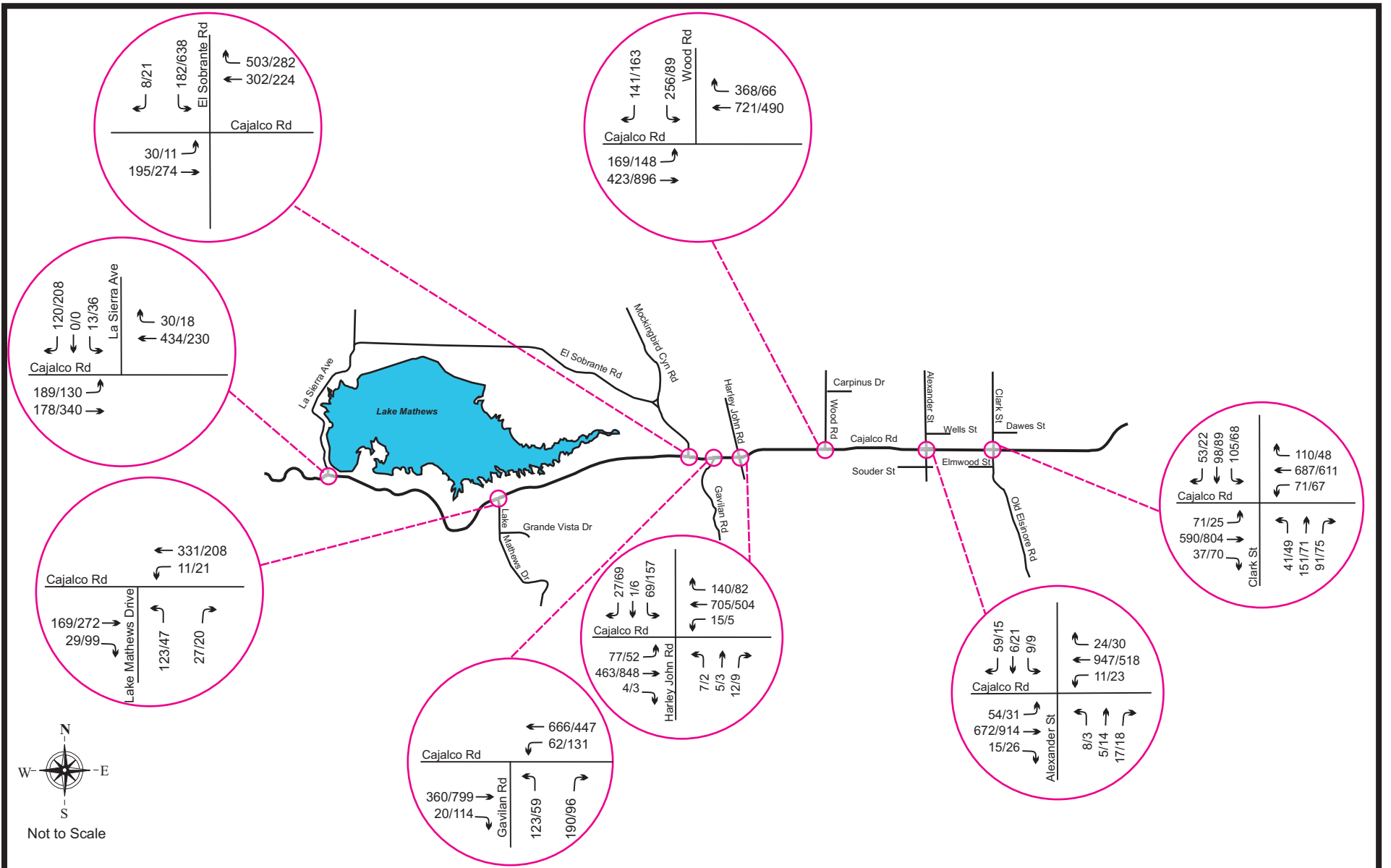

Existing (2010) AM/PM Peak Hour Traffic Intersections

Figure 3-8c

↔ XXX/XXX Peak Hour Traffic AM/PM



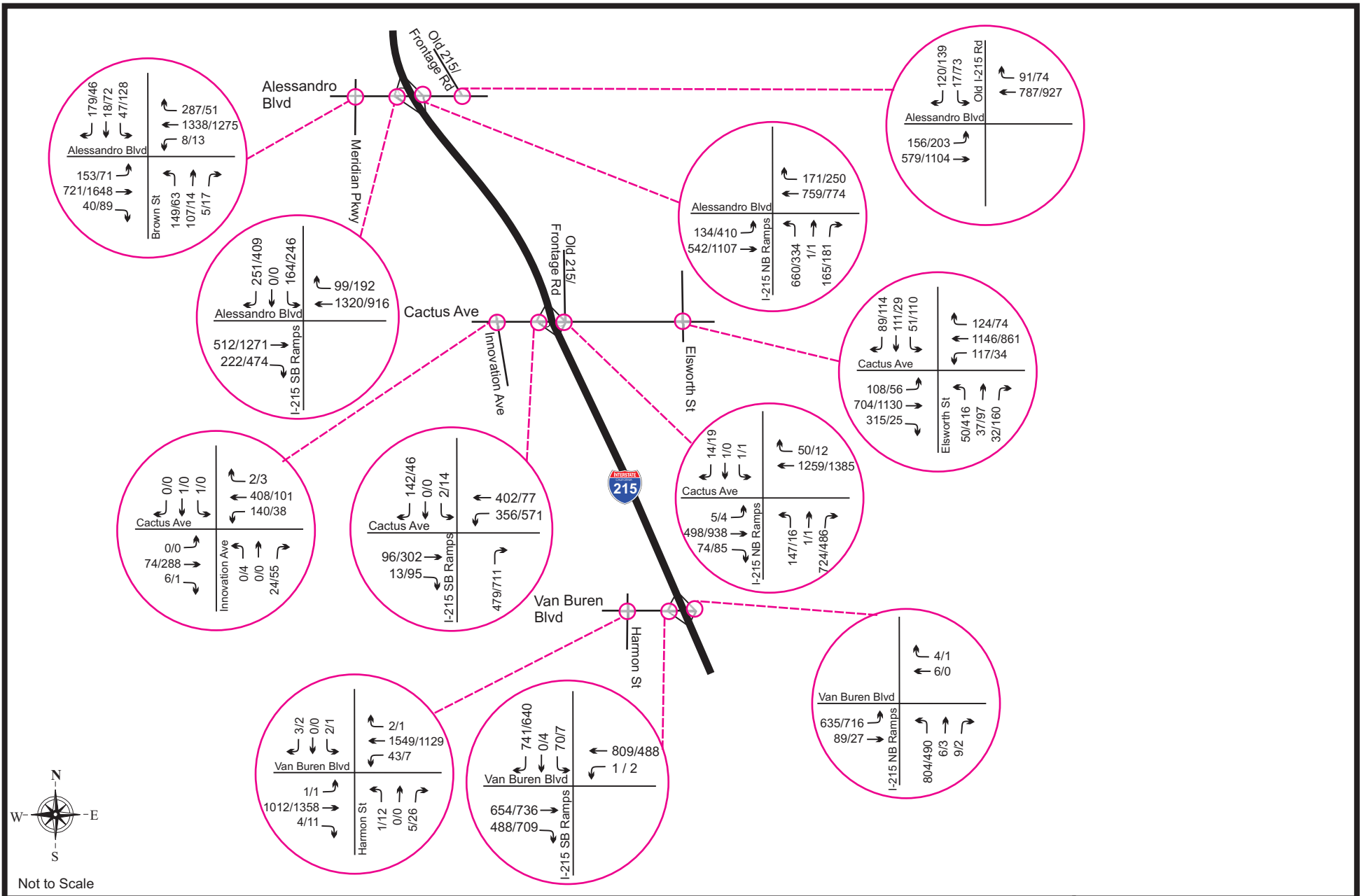

Not to Scale

Existing (2010) AM/PM Peak Hour Traffic Intersections

Figure 3-8d

↪ XXX/XXX Peak Hour Traffic AM/PM



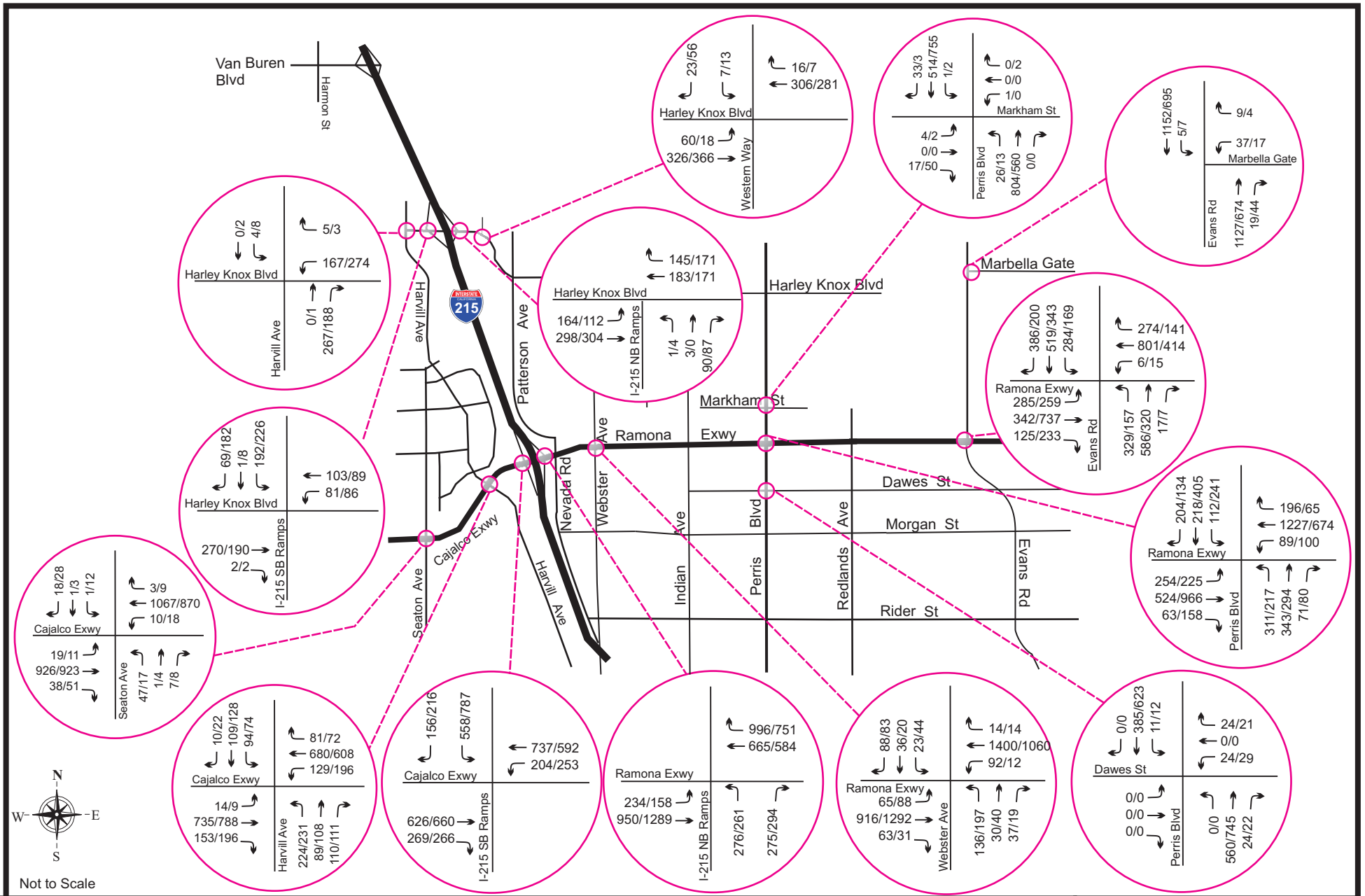

Existing (2010) AM/PM Peak Hour Traffic Intersections

Figure 3-8e



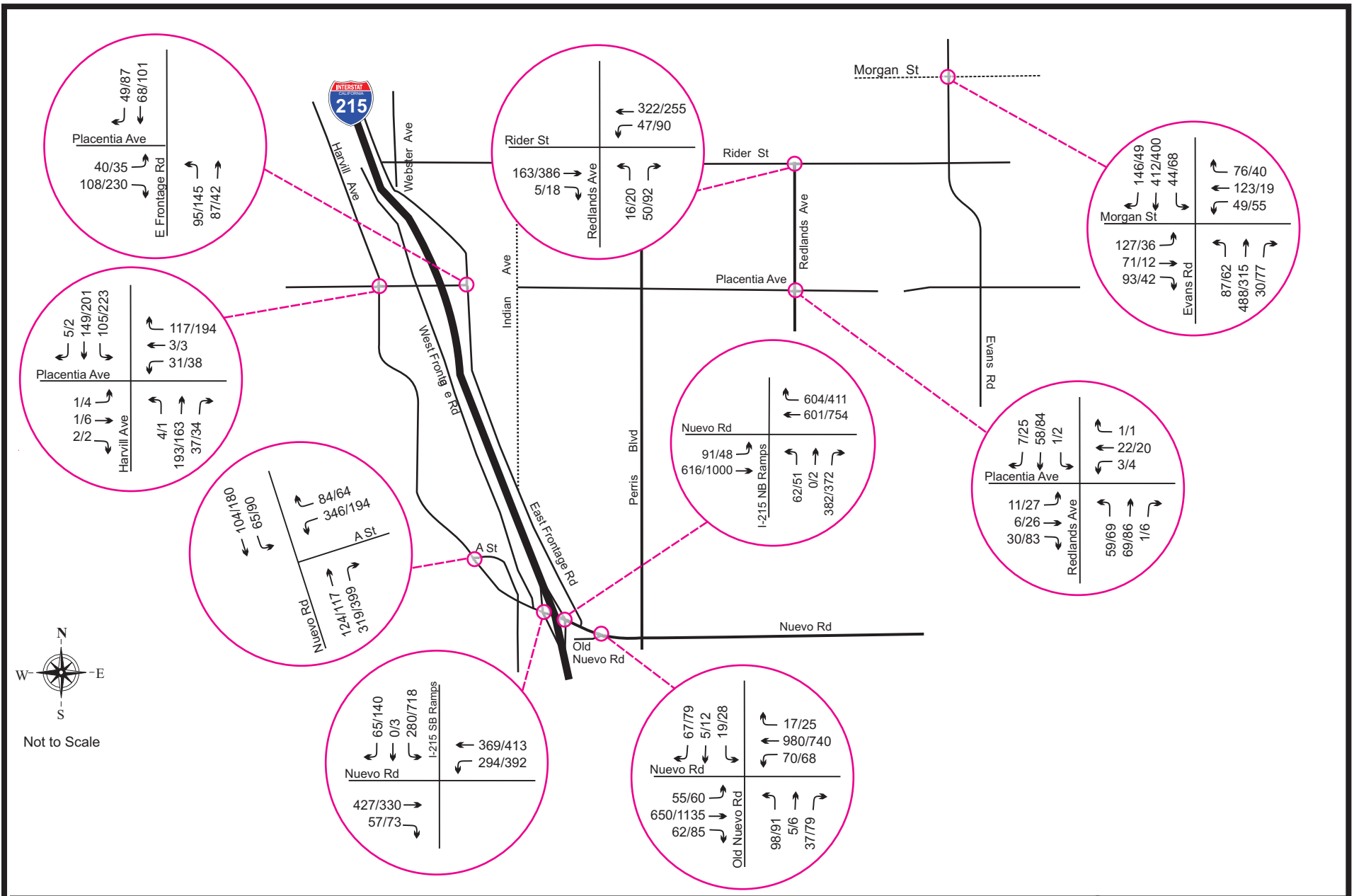

Existing (2010) AM/PM Peak Hour Traffic Intersections

Figure 3-8f

← XXX/XXX Peak Hour Traffic AM/PM



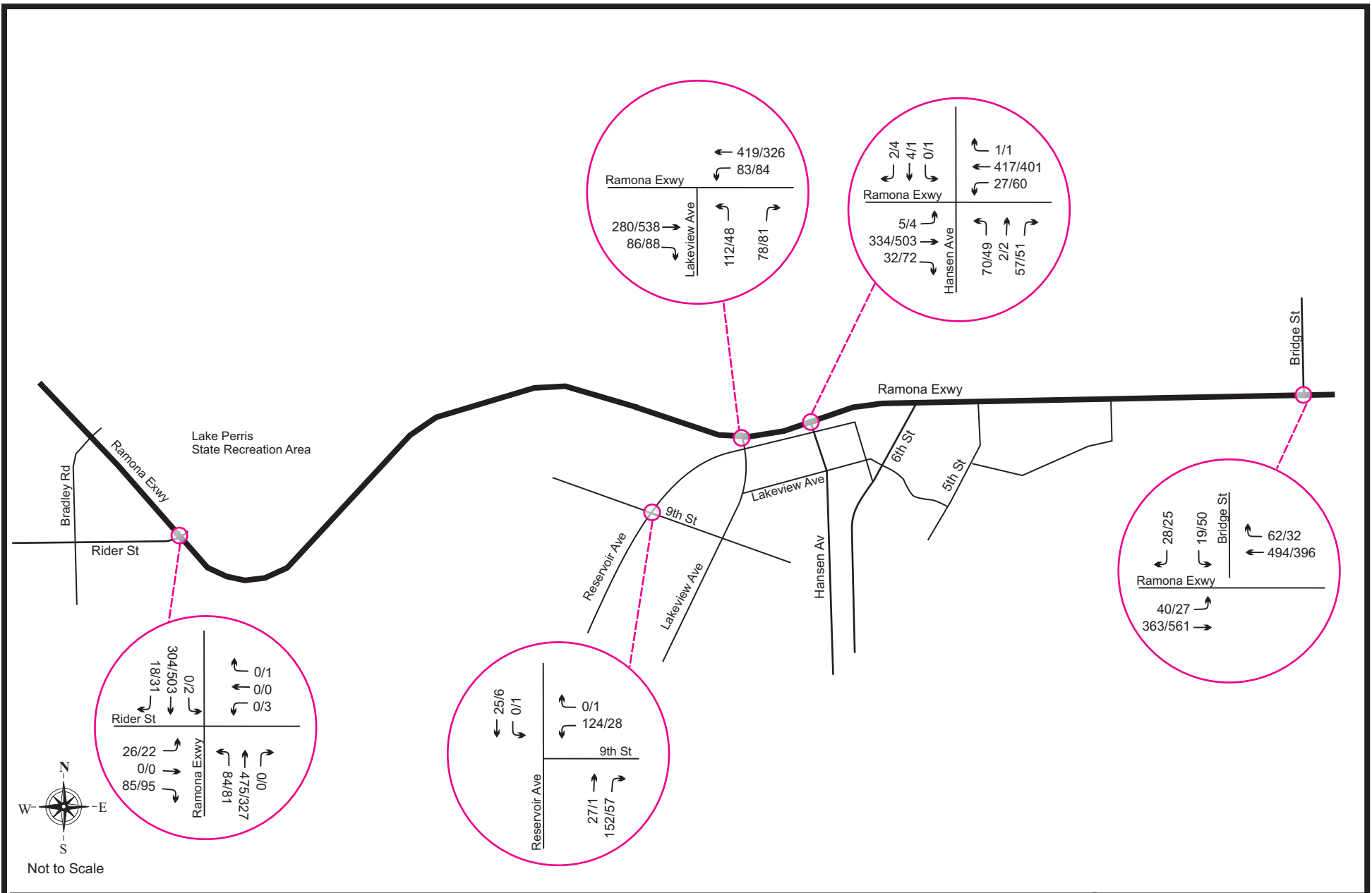

Existing (2010) AM/PM Peak Hour Traffic Intersections

Figure 3-8g

↪ XXX/XXX Peak Hour Traffic AM/PM



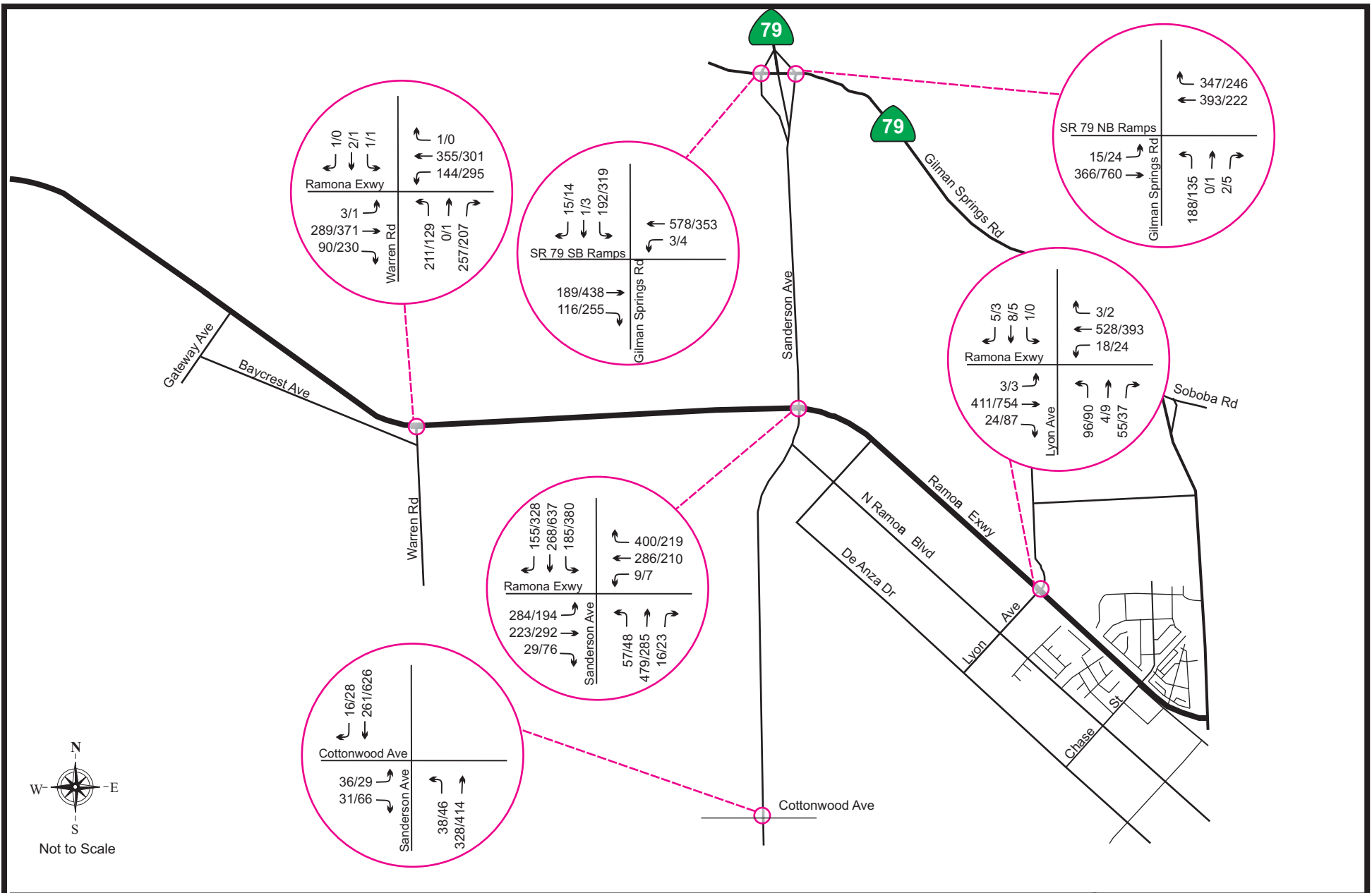

Existing (2010) AM/PM Peak Hour Traffic Intersections

Figure 3-8h

← XXX/XXX Peak Hour Traffic AM/PM



Table 3-1
Existing (2010)
Freeway Capacity Analysis (1)
Interstate 15

Northbound		Peak Hour Traffic (veh/hr)		Number of Lanes	Freeway Capacity (2)	AM Peak Hour		PM Peak Hour	
		AM	PM			LOS (3)	Density (4)	LOS (3)	Density (4)
Location	Facility								
I - 15 Mainline									
South of Temescal Canyon Rd	Freeway	5635	5264	3	6470	D	33.8	D	30.5
Temescal Canyon Rd On Ramp to Weirick Road Off Ramp	Freeway	5111	5559	3	6470	D	29.4	D	33.1
Weirick Road On Ramp to Cajalco Road Off Ramp	Freeway	5964	6030	3	6470	E	37.4	E	38.2
Cajalco Road On Ramp to El Cerrito Road Off Ramp	Freeway	6820	6278	3	6470	F	47.4	E	41.6
El Cerrito Road On Ramp to Ontario Avenue Off Ramp	Freeway	7130	6352	3	6470	F	49.6	E	42.8
Ontario Avenue On Ramp to Magnolia Avenue Off Ramp	Freeway	7095	6842	3	6470	F	49.3	F	47.6
North of Magnolia Avenue	Freeway	6900	7928	4	6470	D	29.3	E	36.6

(1) Capacity analysis is shown for freeway only. See separate page of Table 3-1 for ramps.

(2) Freeway capacity is defined as the capacity at level of service E, expressed in vehicles per hour.

(3) LOS = Level of Service.

(4) Density is expressed in passenger cars/mile/lane.

Table 3-1 (cont.)
Existing (2010)
Ramp Capacity Analysis (1)
Interstate 15

Northbound		Peak Hour Traffic (veh/hr)				Number of Lanes		Freeway Capacity (1)	AM Peak Hour		PM Peak Hour	
		AM		PM		Freeway	Ramp		LOS (2)	Density (3)	LOS (2)	Density (3)
Location	Facility	Freeway	Ramp	Freeway	Ramp	Freeway	Ramp					
I - 15 Mainline												
Temescal Canyon Rd Off Ramp	Diverge	5635	849	5264	131	3		6470	D	32.9	D	30.2
Temescal Canyon Rd On Ramp	Merge	4786	325	5133	426	3	1	6470	D	28.9	D	31.5
Weirick Road Off Ramp	Diverge	5111	137	5559	88	3	1	6470	D	29.6	D	31.5
Weirick Road On Ramp	Merge	4974	990	5471	559	3	1	6470	E	35.2	D	34.2
Cajalco Road Off Ramp	Diverge	5964	157	6030	335	3	1	6470	D	33.2	D	33.7
Cajalco Road On Ramp	Merge	5807	1013	5695	583	3	1	6470	F	47.4	E	35.5
El Cerrito Road Off Ramp	Diverge	6820	393	6278	190	3	1	6470	F	50.2	D	34.5
El Cerrito Road On Ramp	Merge	6427	703	6088	264	3	1	6470	F	49.6	D	35.0
Ontario Avenue Off Ramp	Diverge	7130	970	6352	470	3	1	6470	F	56.3	E	35.1
Ontario Avenue On Ramp	Merge	6160	935	5882	960	3	1	6470	F	49.3	F	47.6
Magnolia Avenue Off Ramp	Diverge	7095	1078	6842	469	3	1	6470	F	56.8	F	50.8
Magnolia Avenue On Ramp	Merge	6017	883	6373	1555	3	1	6470	F	48.0	F	55.1

(1) Capacity analysis is shown for ramps only. See separate page of Table 3-1 for freeway segments.

(2) LOS = Level of Service.

(3) Density is expressed in passenger cars/mile/lane.

Table 3-1 (cont.)
Existing (2010)
Freeway Capacity Analysis (1)
Interstate 15

Southbound		Peak Hour Traffic (veh/hr)		Number of Lanes	Freeway Capacity (2)	AM Peak Hour		PM Peak Hour	
		AM	PM			LOS (3)	Density (4)	LOS (3)	Density (4)
Location	Facility								
I - 15 Mainline									
North of Magnolia Avenue	Freeway	7911	8440	4	6470	E	36.4	E	41.8
Magnolia Avenue On Ramp to Ontario Avenue Off Ramp	Freeway	6356	7656	3	6470	E	42.9	F	53.2
Ontario Avenue On Ramp to El Cerrito Road Off Ramp	Freeway	5603	7607	3	6470	D	33.5	F	52.9
El Cerrito Road On Ramp to Cajalco Road Off Ramp	Freeway	5580	7673	3	6470	D	33.3	F	53.4
Cajalco Road On Ramp to Weirick Road Off Ramp	Freeway	5291	7519	3	6470	D	30.7	F	52.3
Weirick Road On Ramp to Temescal Canyon Off Ramp	Freeway	4882	6955	3	6470	D	27.7	F	48.4
South of Temescal Canyon Road	Freeway	4674	6768	3	6470	D	26.4	F	47.1

(1) Capacity analysis is shown for freeway only. See separate page of Table 3-1 for ramps.

(2) Freeway capacity is defined as the capacity at level of service E, expressed in vehicles per hour.

(3) LOS = Level of Service.

Table 3-1 (cont.)
Existing (2010)
Ramp Capacity Analysis (1)
Interstate 15

Southbound		Peak Hour Traffic (veh/hr)				Number of Lanes		Freeway Capacity (1)	AM Peak Hour		PM Peak Hour	
		AM		PM					LOS (2)	Density (3)	LOS (2)	Density (3)
Location	Facility	Freeway	Ramp	Freeway	Ramp	Freeway	Ramp					
I - 15 Mainline												
Magnolia Avenue Off Ramp	Diverge	7911	1888	8440	1401	3	1	6470	F	41.9	F	49.0
Magnolia Avenue On Ramp	Merge	6023	333	7039	617	3	1	6470	E	35.2	F	44.7
Ontario Avenue Off Ramp	Diverge	6356	1110	7656	812	3	1	6470	E	36.2	F	47.6
Ontario Avenue On Ramp	Merge	5246	357	6844	763	3	1	6470	D	31.5	F	42.3
El Cerrito Road Off Ramp	Diverge	5603	305	7607	510	3	1	6470	D	31.9	F	49.4
El Cerrito Road On Ramp	Merge	5298	282	7097	576	3	1	6470	D	31.1	F	45.4
Cajalco Road Off Ramp	Diverge	5580	457	7673	597	3	1	6470	D	32.1	F	49.2
Cajalco Road On Ramp	Merge	5123	168	7076	443	3	1	6470	D	29.4	F	46.1
Weirick Road Off Ramp	Diverge	5291	458	7519	715	3	1	6470	D	30.8	F	47.3
Weirick Road On Ramp	Merge	4833	49	6804	151	3	1	6470	C	26.9	F	46.3
Temescal Canyon Road Off Ramp	Diverge	4882	288	6955	430	3	1	6470	D	28.8	F	45.4
Temescal Canyon Road On Ramp	Merge	4594	80	6525	243	3	1	6470	C	26.0	F	43.7

(1) Capacity analysis is shown for ramps only. See separate page of Table 3-1 for freeway segments.

(2) LOS = Level of Service.

(3) Density is expressed in passenger cars/mile/lane.

Table 3-2
Existing (2010)
Freeway Capacity Analysis (1)
Interstate 215

Northbound		Peak Hour Traffic (veh/hr)		Number of Lanes	Freeway Capacity (2)	AM Peak Hour		PM Peak Hour	
		AM	PM			LOS (3)	Density (4)	LOS (3)	Density (4)
Location	Facility								
I - 215 Mainline									
Nuevo Road On Ramp to Ramona Expressway Off Ramp	Freeway	4559	4476	3	6470	C	25.7	C	25.2
Ramona Expressway On Ramp to Oleander Ave Off Ramp	Freeway	5238	4830	3	6470	D	30.3	D	27.4
Harley Knox Blvd On Ramp to Van Buren Blvd Off Ramp	Freeway	5456	5022	3	6470	D	32.1	D	28.7
Van Buren Blvd On Ramp to Cactus Ave Off Ramp	Freeway	5282	5247	3	6470	D	30.7	D	30.4
Cactus Ave On Ramp to Alessandro Blvd Off Ramp	Freeway	5151	5598	3	6470	D	29.6	D	33.4
North of Alessandro Blvd	Freeway	4631	5743	3	6470	D	26.1	D	34.9

(1) Capacity analysis is shown for freeway only. See separate page of Table 3-2 for ramps.

(2) Freeway capacity is defined as the capacity at level of service E, expressed in vehicles per hour.

(3) LOS = Level of Service.

(4) Density is expressed in passenger cars/mile/lane.

Table 3-2 (cont.)
Existing (2010)
Ramp Capacity Analysis (1)
Interstate 215

Northbound		Peak Hour Traffic (veh/hr)				Number of Lanes		AM Peak Hour		PM Peak Hour	
		AM		PM							
Location	Facility	Freeway	Ramp	Freeway	Ramp	Freeway	Ramp	LOS (2)	Density (3)	LOS (2)	Density (3)
I - 215 Mainline											
D Street On Ramp to Nuevo Rd Off Ramp	Weave (4)	4308		4440		3		C	26.4	C	26.8
Nuevo Rd Off Ramp	Diverge (5)	4308	444	4440	425	3	1	C	26.3	C	26.9
Nuevo Road On Ramp	Merge	3864	695	4015	461	3	1	C	27.2	C	26.1
Ramona Expressway Off Ramp	Diverge	4559	551	4476	555	3	1	C	27.7	C	27.3
Ramona Expressway On Ramp	Merge	4008	1230	3921	909	3	1	D	32.2	D	29.2
Harley Knox Blvd Off Ramp	Diverge	5238	94	4830	91	3	1	D	30.1	D	28.2
Harley Knox Blvd On Ramp	Merge	5144	312	4739	283	3	1	D	30.6	D	28.3
Van Buren Blvd Blvd Off Ramp	Diverge	5456	819	5022	495	3	1	D	32.1	D	29.7
Van Buren Blvd On Ramp	Merge	4637	645	4527	720	3	1	D	30.7	D	30.8
Cactus Ave Off Ramp	Diverge	5282	872	5247	503	3	1	D	31.5	D	30.7
Cactus Ave On Ramp	Merge	4410	741	4744	854	3	1	D	30.4	D	32.9
Alessandro Blvd Off Ramp	Diverge	5151	826	5598	516	3	1	D	30.9	D	32.2
Alessandro Blvd On Ramp	Merge	4325	306	5082	661	3	1	C	26.5	D	33.1

(1) Capacity analysis is shown for ramps only. See separate page of Table 3-2 for freeway segments.

(2) LOS = Level of Service.

(3) Density is expressed in passenger cars/mile/lane.

(4) For weaving volumes, see Figure 3-7c. The ramp to ramp movement was assumed to be zero. The weaving length is 2,000 feet.

(5) Ramp capacity analysis shown for information only, since this is technically part of a weaving section.

Table 3-2 (cont.)
Existing (2010)
Freeway Capacity Analysis (1)
Interstate 215

Southbound		Peak Hour Traffic (veh/hr)		Number of Lanes	Freeway Capacity (2)	AM Peak Hour		PM Peak Hour	
		AM	PM			LOS (3)	Density (4)	LOS (3)	Density (4)
Location	Facility								
I - 215 Mainline									
North of Alessandro Blvd	Freeway	5134	6168	3	6470	D	29.5	E	40.0
Alessandro Blvd On Ramp to Cactus Avenue Off Ramp	Freeway	5040	6179	3	6470	D	28.8	E	40.2
Cactus Avenue On Ramp to Van Buren Blvd Off Ramp	Freeway	4786	6074	3	6470	D	27.1	E	38.7
Van Buren Blvd On Ramp to Oleander Road Off Ramp	Freeway	4464	6138	3	6470	C	25.1	E	39.6
Harley Knox Blvd On Ramp to Cajalco Road Off Ramp	Freeway	4286	5818	3	6470	C	24.1	E	35.7
Cajalco Road On Ramp to Nuevo Road Off Ramp	Freeway	4045	5334	3	6470	C	22.7	D	31.1

(1) Capacity analysis is shown for freeway only. See separate page of Table 3-2 for ramps.

(2) Freeway capacity is defined as the capacity at level of service E, expressed in vehicles per hour.

(3) LOS = Level of Service.

(4) Density is expressed in passenger cars/mile/lane.

Table 3-2 (cont.)
Existing (2010)
Ramp Capacity Analysis (1)
Interstate 215

Southbound		Peak Hour Traffic (veh/hr)				Number of Lanes		AM Peak Hour		PM Peak Hour	
		AM		PM							
Location	Facility	Freeway	Ramp	Freeway	Ramp	Freeway	Ramp	LOS (2)	Density (3)	LOS (2)	Density (3)
I - 215 Mainline											
Alessandro Blvd Off Ramp	Diverge	5134	415	6168	655	3	1	D	30.1	D	34.7
Alessandro Blvd On Ramp	Merge	4719	321	5513	666	3	1	D	28.6	E	35.3
Cactus Avenue Off ramp	Diverge	5040	623	6179	771	3	1	D	30.0	D	34.9
Cactus Avenue On Ramp	Merge	4417	369	5408	666	3	1	C	27.4	D	34.8
Van Buren Blvd Off Ramp	Diverge	4786	811	6074	651	3	1	D	29.2	D	34.3
Van Buren Blvd On Ramp	Merge	3975	489	5423	715	3	1	C	26.2	E	35.2
Harley Knox Blvd Off Ramp	Diverge	4464	262	6138	416	3	1	C	26.8	D	34.2
Harley Knox Blvd On Ramp	Merge	4202	84	5722	96	3	1	C	24.1	D	31.8
Cajalco Expwy Off Ramp	Diverge	4286	714	5818	1003	3	1	C	26.7	D	33.9
Cajalco Expwy On Ramp	Merge	3572	473	4815	519	3	1	C	24.0	D	30.6
Nuevo Road Off Ramp	Diverge	4045	345	5334	861	3	1	C	24.9	D	31.7
Nuevo Rd On Ramp	Merge (4)	3700	351	4473	468	3	1	C	23.7	D	28.5
Nuevo Rd On Ramp to D Street Off Ramp	Weave (5)	4051		4941		3		C	25.7	D	33.9

(1) Capacity analysis is shown for ramps only. See separate page of Table 3-2 for freeway segments.

(2) LOS = Level of Service.

(3) Density is expressed in passenger cars/mile/lane.

(4) Ramp capacity analysis shown for information only, since this is technically part of a weaving section.

(5) For weaving volumes, see Figure 3-7c. The ramp to ramp movement was assumed to be zero. The weaving length is 2,000 feet.

Table 3-3
Existing (2010)
Intersection Capacity Analysis
I-15 Area

Intersection	AM Peak Hour		PM Peak Hour	
	LOS	Average Delay (sec)	LOS	Average Delay (sec)
Magnolia Avenue and El Sobrante Road	D	45.1	D	54.7
Magnolia Avenue and I-15 Southbound Ramps	F	>80.0	E	73.1
Magnolia Avenue and I-15 Northbound Ramps	C	20.3	B	12.4
Magnolia Avenue and El Camino Avenue	B	13.3	B	14.7
Ontario Avenue and California Avenue	C	25.5	C	34.2
Ontario Avenue and I-15 Southbound Ramps	C	23.4	B	18.0
Ontario Avenue and I-15 Northbound Ramps	D	36.2	C	28.1
Ontario Avenue and State Street	E	44.8	E	46.8
El Cerrito Road and Bedford Canyon Road	B	15.3	B	18.3
El Cerrito Road and I-15 Southbound Ramps	B	10.6	A	6.5
El Cerrito Road and I-15 Northbound Ramps	D	35.1	C	25.4
El Cerrito Road and Temescal Canyon Road	E	49.7	D	27.7
Cajalco Road and Bedford Canyon Road	A	7.1	B	13.2
Cajalco Road and I-15 Southbound Ramps	C	22.4	C	27.3
Cajalco Road and I-15 Northbound Ramps	B	17.5	B	15.6
Cajalco Road and Temescal Canyon Road	C	28.1	C	27.5
Cajalco Road and Eagle Valley Rd	B	13.2	B	12.6
Weirick Road and Knabe Road	B	10.4	B	13.2
Weirick Road and I-15 Southbound Ramps	B	12.5	B	15.1
Weirick Road and I-15 Northbound Ramps	B	16.3	B	17.2
Weirick Road and Temescal Canyon Road	B	12.4	B	11.8
Temescal Canyon Road and Lawson Drive	C	17.8	C	18.0
Temescal Canyon Road and I-15 Southbound Ramps	B	12.4	B	15.9
Temescal Canyon Road and I-15 Northbound Ramps	C	32.7	C	27.5

Notes:

">50" – Exceeds 50 seconds, the threshold for level of service F at an unsignalized intersection.

">80" – Exceeds 80 seconds, the threshold for level of service F at a signalized intersection.

Table 3-3 (Cont.)
Existing (2010)
Intersection Capacity Analysis
Cajalco Road, I-15 to I-215

Intersection	AM Peak Hour		PM Peak Hour	
	LOS	Average Delay (sec)	LOS	Average Delay (sec)
Cajalco Road and La Sierra Avenue	B	16.3	B	14.7
Cajalco Road and Lake Matthew Road	C	15.1	B	12.9
Cajalco Road and El Sobrante Road	B	11	C	20.2
Cajalco Road and Gavilan Road	B	10.5	B	14.6
Cajalco Road and Harley John Road	C	25.9	C	25.5
Cajalco Road and Wood Road	C	21.8	B	13.8
Cajalco Road and Alexander Street	F	>80.0	F	72.8
Cajalco Road and Clark Street	D	35.6	C	26.0
Cajalco Road and Seaton Avenue	F	>50.0	F	>50.0

Notes:

- ">50" – Exceeds 50 seconds, the threshold for level of service F at an unsignalized intersection.
- ">80" – Exceeds 80 seconds, the threshold for level of service F at a signalized intersection.

Table 3-3 (Cont.)
Existing (2010)
Intersection Capacity Analysis
I-215 Area

Intersection	AM Peak Hour		PM Peak Hour	
	LOS	Average Delay (sec)	LOS	Average Delay (sec)
Alessandro Blvd and Meridian Parkway	B	19.0	B	11.1
Alessandro Blvd and I-215 Southbound Ramps	B	10.1	B	10.2
Alessandro Blvd and I-215 Northbound Ramps	C	24.8	C	23.2
Alessandro Blvd and Valley Springs Parkway	A	9.4	B	10.4
Cactus Avenue and Innovation Drive	C	19.5	B	12.8
Cactus Avenue and I-215 Southbound Ramps	B	11.7	C	22.1
Cactus Avenue and I-215 Northbound Ramps	B	10.2	A	3.0
Cactus Avenue and Ellsworth Street	C	27.0	D	47.4
Van Buren Boulevard and Harmon Street	B	13.6	C	25.9
Van Buren Boulevard and I-215 Southbound Ramps	F	>50.0	F	>50.0
Van Buren Boulevard and I-215 Northbound Ramps	E	76.1	C	22.0
Harley Knox Boulevard and Harvill Avenue	A	9.9	B	12.0
Harley Knox Boulevard and I-215 Southbound Ramps	C	26.6	C	28.5
Harley Knox Boulevard and I-215 Northbound Ramps	B	12.1	A	9.2
Harley Knox Boulevard and Western Way	B	10.8	B	10.4
Cajalco Road and Harvill Avenue	C	22.1	C	23.8
Cajalco Road and I-215 Southbound Ramps	C	31.0	D	50.9
Cajalco Road and I-215 Northbound Ramps	C	22.6	B	17.0
Ramona Expressway and Webster Avenue	C	20.7	C	21.9
Placentia Avenue and Harvill Avenue	C	15.4	C	24.6
Placentia Avenue and East Frontage Road	A	9.1	B	10.1
Nuevo Road and A Street	E	39.2	D	27.2
Nuevo Road and I-215 Southbound Ramps	C	29.3	D	38.2
Nuevo Road and I-215 Northbound Ramps	B	11.9	B	17.7
Nuevo Road and Old Nuevo Road	B	15.7	B	13.6

Notes:

">50" – Exceeds 50 seconds, the threshold for level of service F at an unsignalized intersection.

">80" – Exceeds 80 seconds, the threshold for level of service F at a signalized intersection.

Table 3-3 (Cont.)
Existing (2010)
Intersection Capacity Analysis
Ramona Expressway, I-215 to SR 79

Intersection	AM Peak Hour		PM Peak Hour	
	LOS	Average Delay (sec)	LOS	Average Delay (sec)
Perris Boulevard and Markham Street	E	44.3	C	17.8
Perris Boulevard and Ramona Expressway	D	35.6	D	36.4
Perris Boulevard and Dawes Street	A	3.4	A	3.3
Evans Boulevard and Marbella Gate	F	>80.0	C	23.3
Evans Road and Ramona Expressway	D	40.3	C	28.5
Evans Boulevard and Morgan Street	C	20.1	B	14.9
Rider Street and Ramona Expressway	B	19.7	C	21.5
Lakeview Avenue and Ramona Expressway	D	27.2	C	24.0
Reservoir Avenue and 9th Street	B	10.0	A	8.8
Hansen Avenue and Ramona Expressway	B	16.6	B	17.5
Bridge Street and Ramona Expressway	C	17.0	C	22.9
Warren Road and Ramona Expressway	B	20.0	C	21.4
Sanderson Avenue and Ramona Expressway	D	36.5	C	33.8
Sanderson Avenue and Cottonwood Avenue	B	12.0	B	11.4
Lyon Avenue and Ramona Expressway	B	10.8	B	11.2
Gilman Springs Road and SR 79 Southbound Ramps	E	44.5	F	>80.0
Gilman Springs Road and SR 79 Northbound Ramps	E	49.2	F	>80.0

Notes:

- ">50" – Exceeds 50 seconds, the threshold for level of service F at an unsignalized intersection.
- ">80" – Exceeds 80 seconds, the threshold for level of service F at a signalized intersection.

4.0 FUTURE TRAFFIC FORECASTS

This chapter provides a description of the methodology used to determine future traffic forecasts. While the basis of the traffic forecasts was the regional transportation model, this chapter provides additional detail on the various versions of the regional model considered during the course of the project and additional detail on refinements to traffic forecasts produced by the model.

Traffic forecasts were based on the Riverside County Traffic Analysis Model (RIVTAM). RIVTAM is a customized and focused version of the Southern California Association of Governments (SCAG) Regional Transportation Plan (RTP) model, which was developed for exclusive use in Riverside County under the auspices of Riverside County, the Riverside County Transportation Commission (RCTC) and SCAG. The model was further updated by the project team to create a refined version specifically applied to develop forecasts for the Mid County Parkway (MCP) Corridor study area, based on the following:

- ◆ Contacts were made with Riverside County, the March Joint Powers Agency (March JPA), and local cities. Input was received to reflect any changes in roadway circulation plans, General Plan land use, and/or major development projects that were not included in the previous RIVTAM model.
- ◆ The roadway network for freeways and State Highways were updated to reflect the 2008 SCAG RTP and current planned roadway improvements proposed by other regional and local transportation agencies.

The approximate boundaries for the refinements listed above are State Route 91/State Route 60 (SR-91/SR-60) on the north, SR-79 on the east, Nuevo Road at I-215/Temescal Canyon Road at I-15 on the south, and I-15 on the west.

The horizon year for the traffic analysis for this project is 2040. Since the horizon year for the RIVTAM model is 2035, a growth factor was used to estimate traffic forecasts for 2040. A 1.9% per year growth factor was used, which is the same growth factor that was used in the previous MCP traffic analysis. This growth factor reflects typical growth in Riverside County based on historical trends under normal economic conditions.

The following adjustments were made to the raw traffic forecasts, which are produced by the focused RIVTAM model:

- ◆ Since the RIVTAM model is a County-wide model, there were cases where the model lacked sufficient detail to forecast traffic on city streets. In these cases, traffic forecasts were used from the local General Plan Circulation Elements for the roadway in question. In cases where a local General Plan Circulation Element did not provide an accurate forecast, traffic forecasts were estimated using forecasts for adjacent roadways.
- ◆ AM and PM peak hour traffic forecasts for freeways and ramps and AM and PM peak hour intersection turning movements were prepared using the methodology described in NCHRP Report #255.

5.0 DETERMINATION OF STUDY AREA

This chapter provides a description of the process used to determine the study area for the traffic analysis, including the methodology and the traffic analysis that was used in this determination.

METHODOLOGY

The traffic analysis described in this Traffic Technical Report provides an analysis of three project alternatives: Alternative 4 Modified, Alternative 5 Modified, and Alternative 9 Modified. These alternatives correspond to a Mid County Parkway (MCP) project that would extend from State Route 79 (SR-79) to Interstate 215 (I-215). During previous steps in the environmental process, a traffic analysis was conducted for an MCP project that would extend from SR-79 to Interstate 15 (I-15). The methodology for determining the traffic analysis study area started with the traffic analysis study area from the previous traffic analysis and was modified as described below.

The traffic analysis study area from the previous traffic analysis extended along the length of the MCP project and also included I-15 from Temescal Canyon Road to SR-91, I-215 from Nuevo Road to Van Buren Boulevard, and Cajalco Road from I-215 to I-15. It was decided that all of this study area would be retained for analysis of the modified project alternatives. While I-15 and portions of Cajalco Road are relatively far away from the modified project alternatives, the potential for the project to increase traffic in these areas was considered to be worthy of consideration.

In addition to retaining the traffic analysis study area from the previous traffic analysis, consideration was given to adding to the study area based on the changes in the project limits and changes in the way that various review agencies evaluate traffic analyses. This led to the following changes:

- ◆ The portion of I-215 from Van Buren Boulevard to north of Alessandro Boulevard was added to the study area including the I-215 interchanges at Cactus Avenue and Alessandro Boulevard. This addition was made because the shorter MCP project was considered to have the potential to cause traffic increases in these areas.
- ◆ The intersection of Ramona Expressway and Lyon Avenue was added to the study area to include one intersection east of the eastern project limits at the MCP/Ramona Expressway intersection.
- ◆ The interchange of SR-79 and Cottonwood Avenue was added to the study area to include one interchange along SR-79 south of the MCP/SR-79 interchange.

Finally, it was considered possible for the shorter MCP project to increase traffic in the area bounded on the east by I-215, on the north by State Route 91 (SR-91), on the west by I-15, and on the south by Cajalco Road. Because this is a fairly large area, the potential for traffic increases was evaluated by analyzing traffic patterns on the major roadways bounding this area and along major roadways leading from the project into this area. This analysis is described in the following section.

TRAFFIC ANALYSIS

For the area bounded on the east by I-215, on the north by SR-91, on the west by I-15, and on the south by Cajalco Road, Figures 5-1 through 5-3 show Horizon Year (2040) Average Daily Traffic (ADT) under No Build conditions and with the MCP project for Alternatives 4 Modified, 5 Modified, and 9 Modified for key roadways that bound this study area or lead into it from the MCP project. Each is described individually below.

I-215: In the area between Cajalco Road/Ramona Expressway and Van Buren Boulevard, the MCP project is expected to add traffic to I-215, but also would provide additional lanes. The net effect of the traffic increase and the added lanes is to improve traffic operations along I-215. This analysis is described in detail in Chapter 7. In the area north of State Route 60 (SR-60), the MCP project would tend to increase traffic by 1,800 to 2,000 vehicles per day (depending on the alternative), an increase of less than 1% as compared to the No Build condition.

SR-91: In the area west of I-215, the MCP project would tend to increase traffic by 900 to 1,000 vehicles per day (depending on the alternative), an increase of less than 1% as compared to the No Build condition. Similarly, near the I-15/SR-91 interchange, the project is also expected to increase traffic by less than 1,000 vehicles per day or less than 1% both east and west of this interchange.

I-15: In the area between Cajalco Road and SR-91, the MCP project would tend to increase traffic by 1,000 to 1,200 vehicles per day (depending on the alternative), an increase of less than 1% as compared to the No Build condition. North of the I-15/SR-91 interchange, the expected traffic increase caused by the project would decrease to 400 to 600 vehicles per day, depending on the alternative.

Cajalco Road: In the area between I-215 and El Sobrante Road, the MCP project would tend to increase traffic by 1,200 to 1,800 vehicles per day (depending on the alternative). West of El Sobrante Road, the expected traffic increase caused by the project would decrease to 1,000 to 1,200 vehicles per day, depending on the alternative. A detailed analysis of Cajalco Road between I-215 and I-15 provided in Chapter 7 indicated that there would be traffic operations would be at level of service D or better in 2040 with or without the project along most of the length of this roadway. The one exception occurs at the intersection of Cajalco Road and Temescal Canyon Road, where level of service F conditions are expected with or without the project. At this location, the project adds less than 1% of total traffic entering the intersection on an AM peak hour or PM peak hour basis.

Alessandro Boulevard: In the area west of I-215, all project alternatives would tend to increase traffic by 500 vehicles per day, an increase of less than 1% as compared to the No Build condition.

Van Buren Boulevard: In the area west of I-215, the MCP project would tend to increase traffic by 3,100 to 3,900 vehicles per day (depending on the alternative). A detailed analysis of the Van Buren Boulevard/Meridian Parkway intersection is included in Chapter 7 that indicates that this intersection would operate at level of service D or better in 2040 in the AM peak hour in the No Build condition and in each of the project alternatives. For 2040 PM peak hour conditions, this intersection would be expected to operate at level of service E for the No Build condition and Alternative 9 and level of service D or better for Alternatives 4 and 5. Therefore, the

project would not cause a degradation of the level of service at this intersection.

STUDY AREA

Based on the analysis described above, the final traffic analysis study area for the project was determined to include the traffic analysis study area from the previous project plus the additions described in the methodology section above.

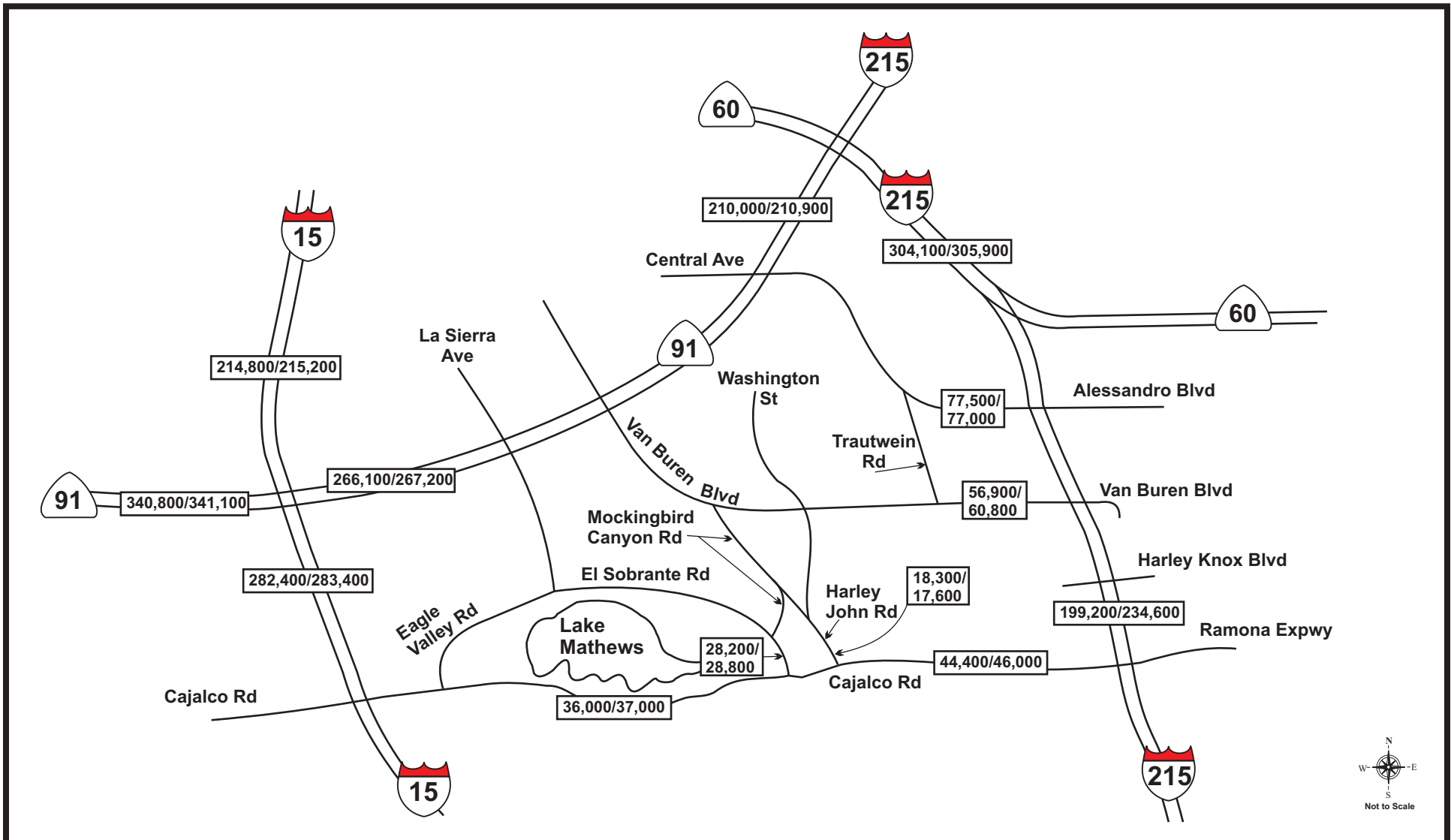

**Horizon Year (2040) Average Daily Traffic
Extended Study Area - Alternative 4 Modified**

Figure 5-1

Legend

-  Existing or Proposed Freeway
-  Existing or Proposed Arterial Street

 No Build ADT/Alternative 4 Modified ADT



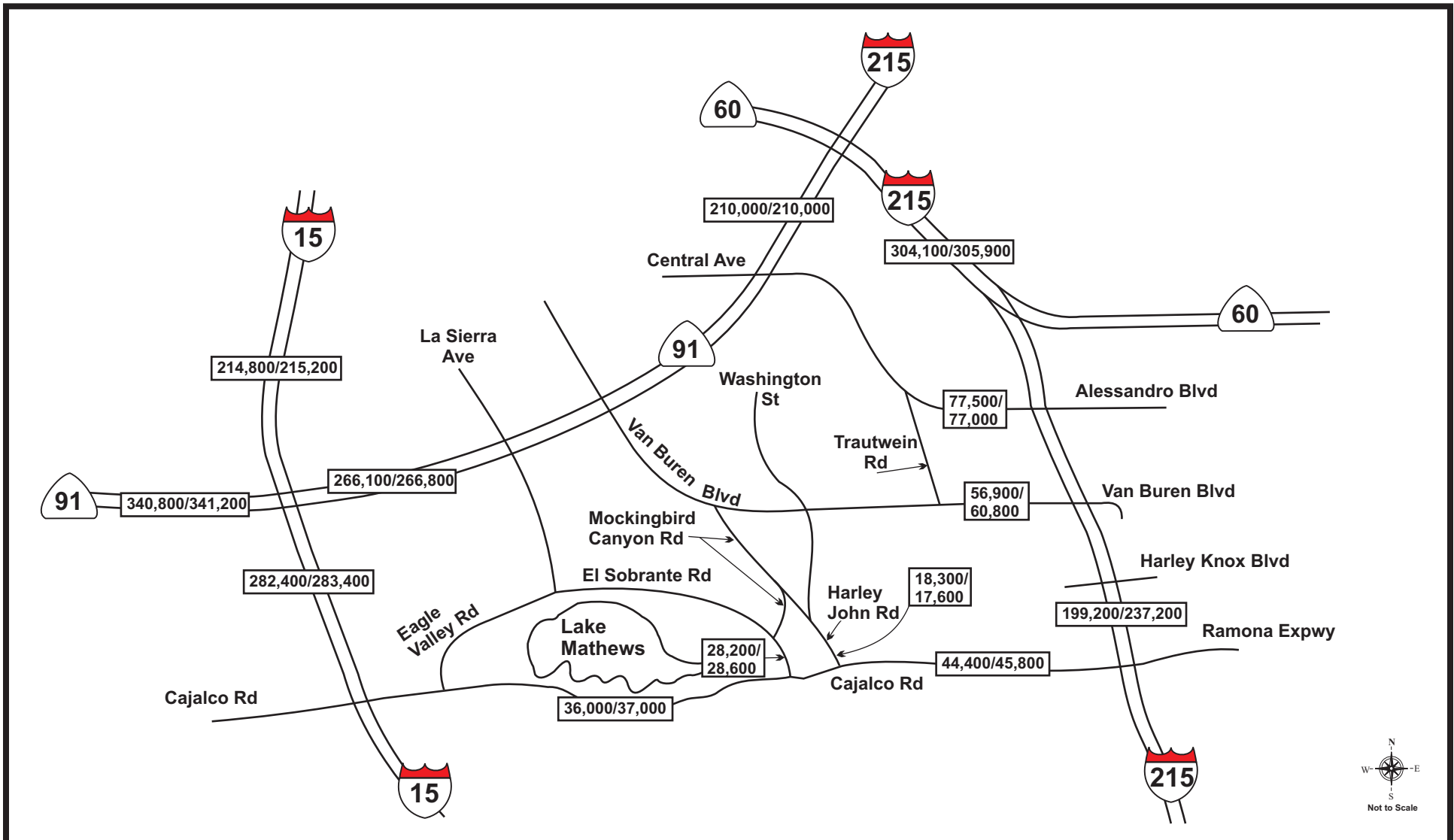



**Horizon Year (2040) Average Daily Traffic
Extended Study Area - Alternative 5 Modified**

Figure 5-2

Legend

-  Existing or Proposed Freeway
-  Existing or Proposed Arterial Street

 No Build ADT/Alternative 5 Modified ADT



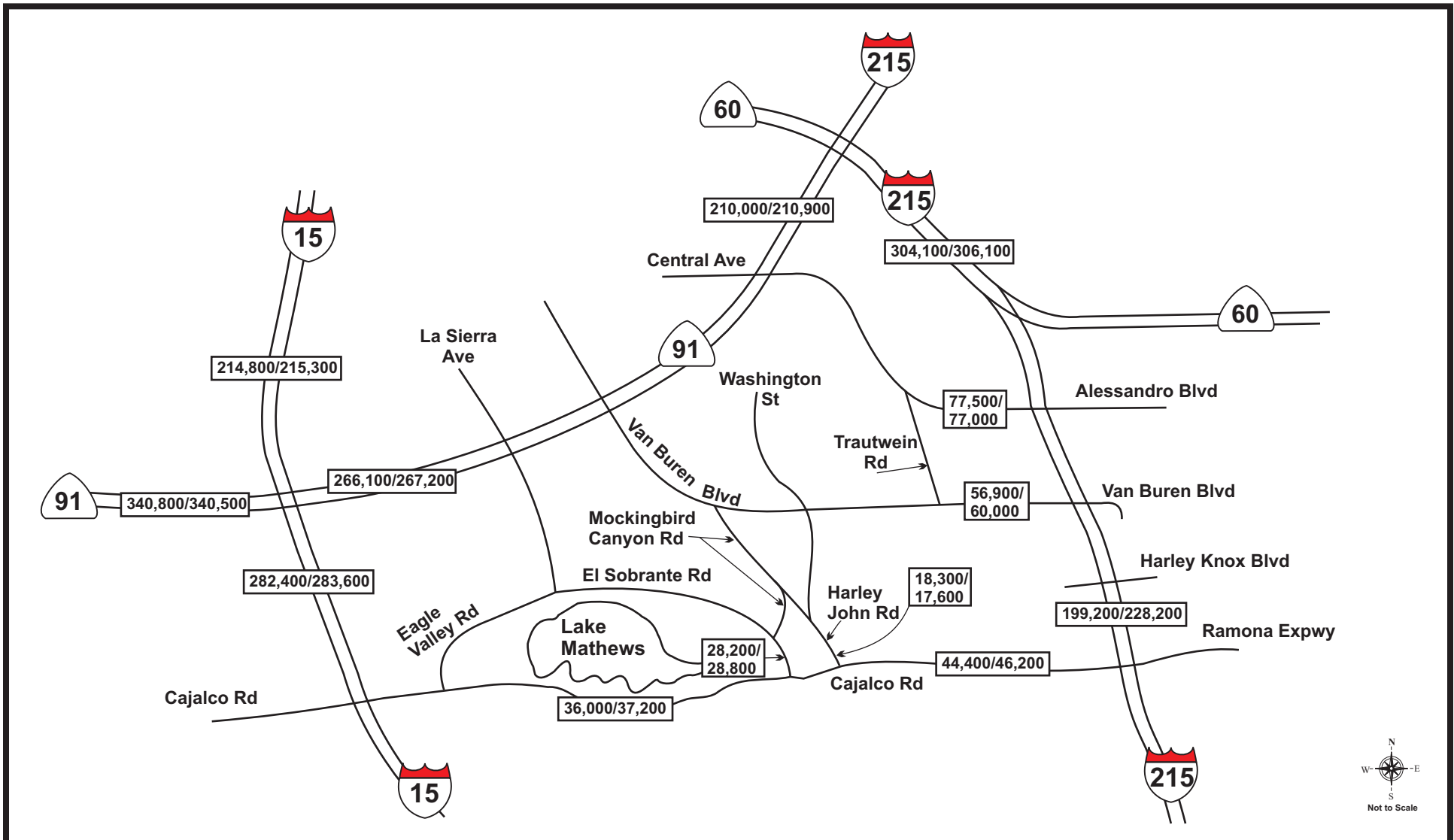



**Horizon Year (2040) Average Daily Traffic
Extended Study Area - Alternative 9 Modified**

Figure 5-3

Legend

-  Existing or Proposed Freeway
-  Existing or Proposed Arterial Street
-  XX,XXX/XX,XXX No Build ADT/Alternative 9 Modified ADT



6.0 OPENING YEAR (2020) CONDITIONS

This Chapter provides analysis of expected 2020 No Build and Build traffic conditions. As described in Chapter 2, the proposed 2020 project is an interim phased Mid County Parkway (MCP) project that would include a four-lane MCP from west of Reservoir Avenue to east of Warren Road, an interchange at Interstate 215 (I-215)/Placentia Avenue, and one additional lane in each direction on I-215 from Nuevo Road to Van Buren Boulevard.

2020 NO BUILD TRAFFIC CONDITIONS

Traffic forecasts for No Build traffic conditions are provided in Figures 6-1 through 6-8. Capacity analysis for No Build conditions is shown in Tables 6-1 through 6-3.

2020 BUILD TRAFFIC CONDITIONS

Traffic forecasts and lane geometry assumptions for Build conditions are documented in Figures 6-9 through 6-18. Capacity analysis is shown in Tables 6-4 through 6-8.

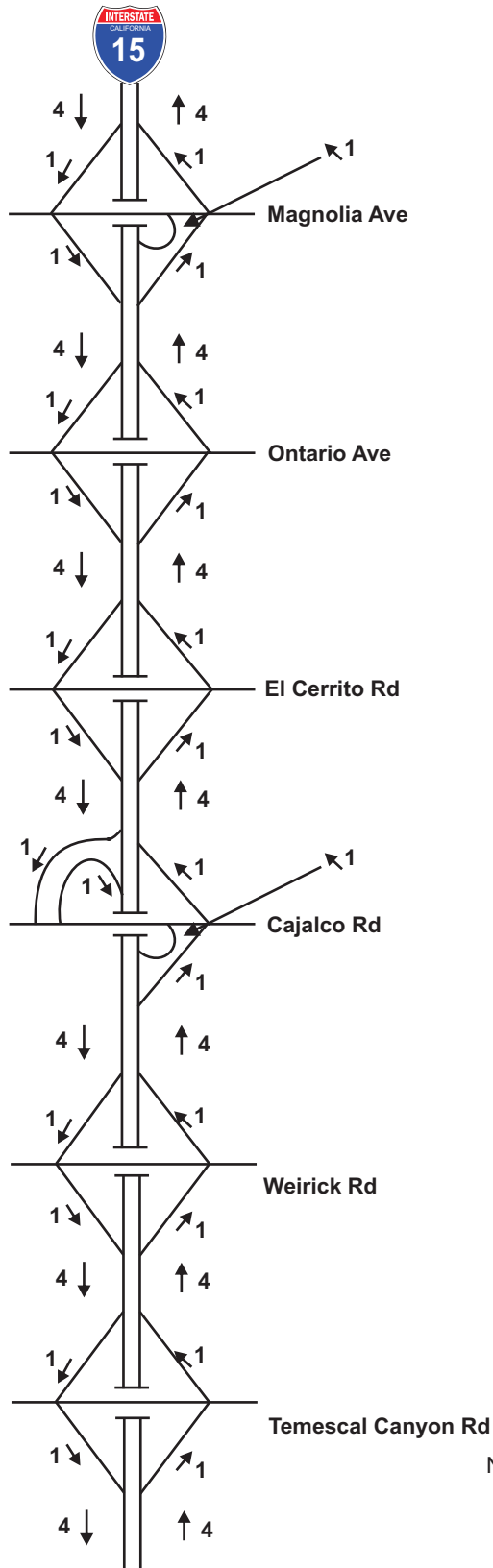

**Opening Year (2020) Freeway Mainline
Lane Geometry Interstate 15 - No Build**

Figure 6-1

Legend

- Direction of Travel
- X : Number of Lanes (Mixed Flow)



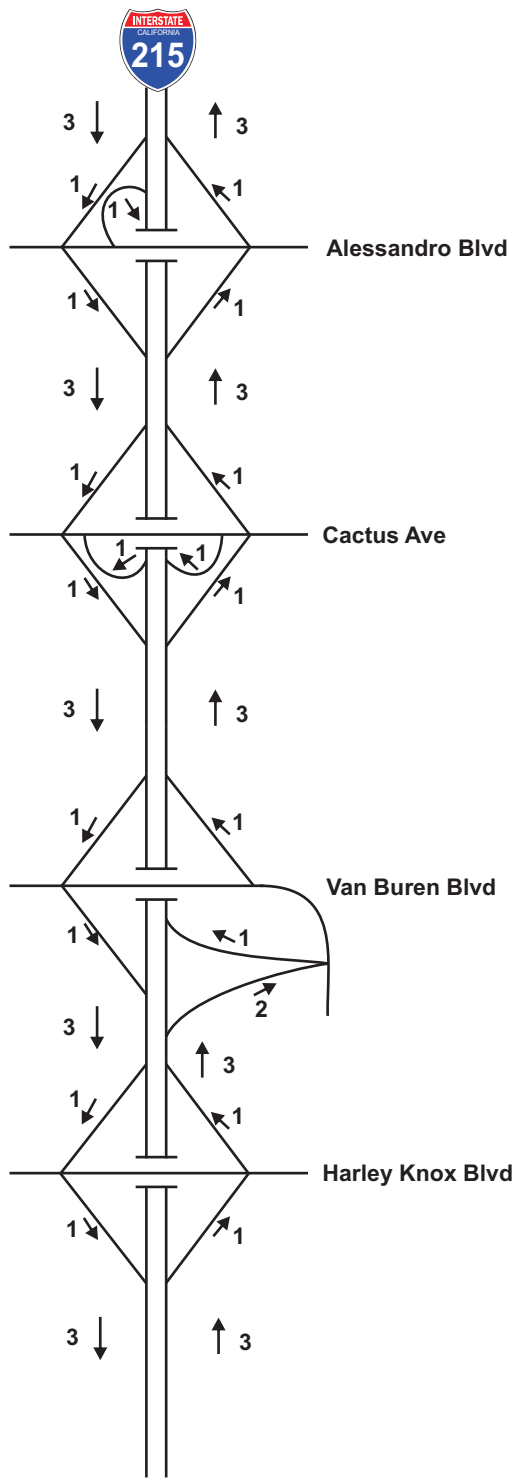

**Opening Year (2020)
Freeway Mainline Lane Geometry
Interstate 215 - No Build**

Figure 6-2a

- Legend**
- Direction of Travel
 - X : Number of Lanes (Mixed Flow)



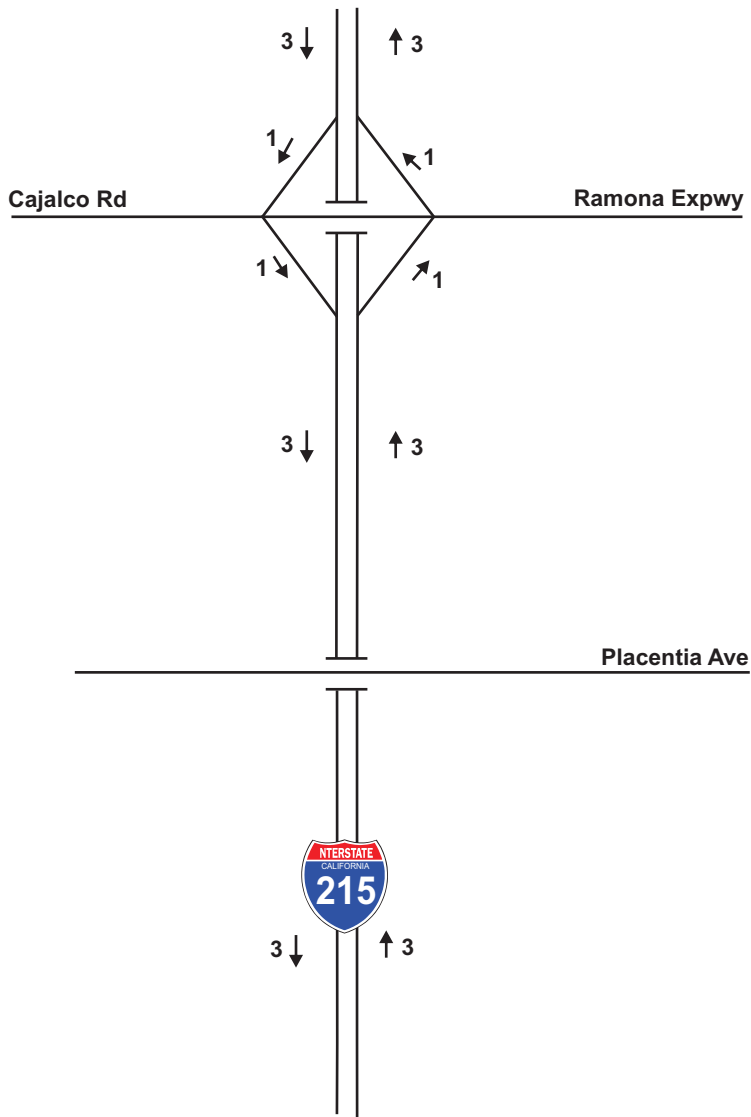

**Opening Year (2020)
Freeway Mainline Lane Geometry
Interstate 215 - No Build**

Figure 6-2b

- Legend**
- Direction of Travel
 - X : Number of Lanes (Mixed Flow)



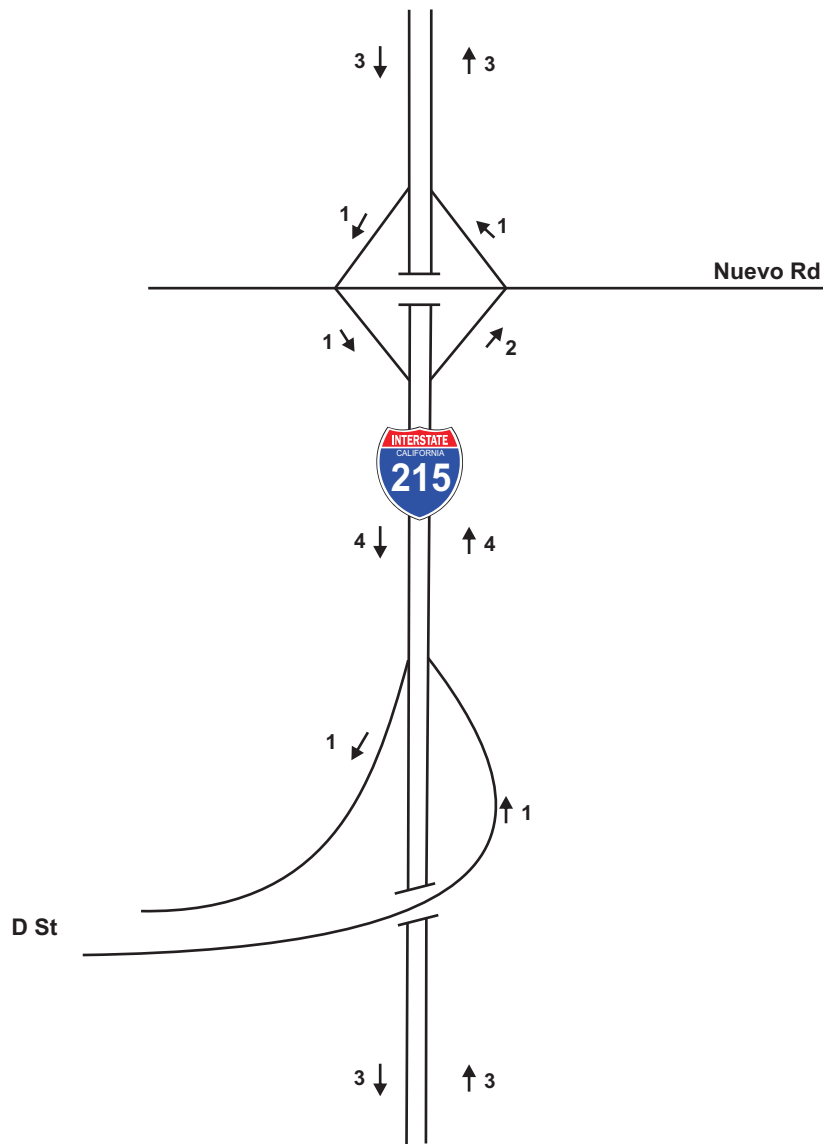

**Opening Year (2020)
Freeway Mainline Lane Geometry
Interstate 215 - No Build**

Figure 6-2c

- Legend**
- Direction of Travel
 - X : Number of Lanes (Mixed Flow)



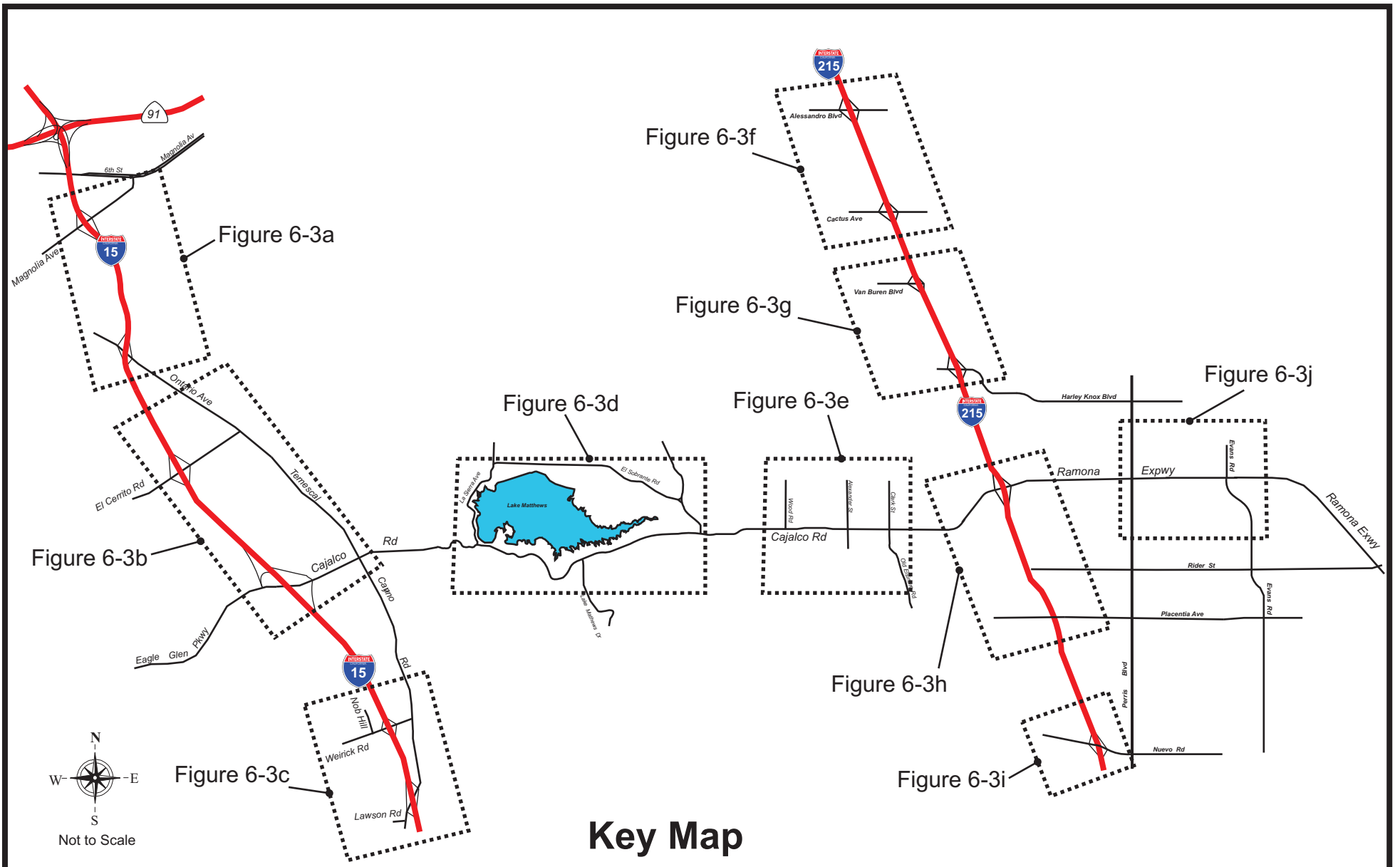

**Horizon Year (2020) Intersection Lane Geometry
No Build**

Figure 6-3



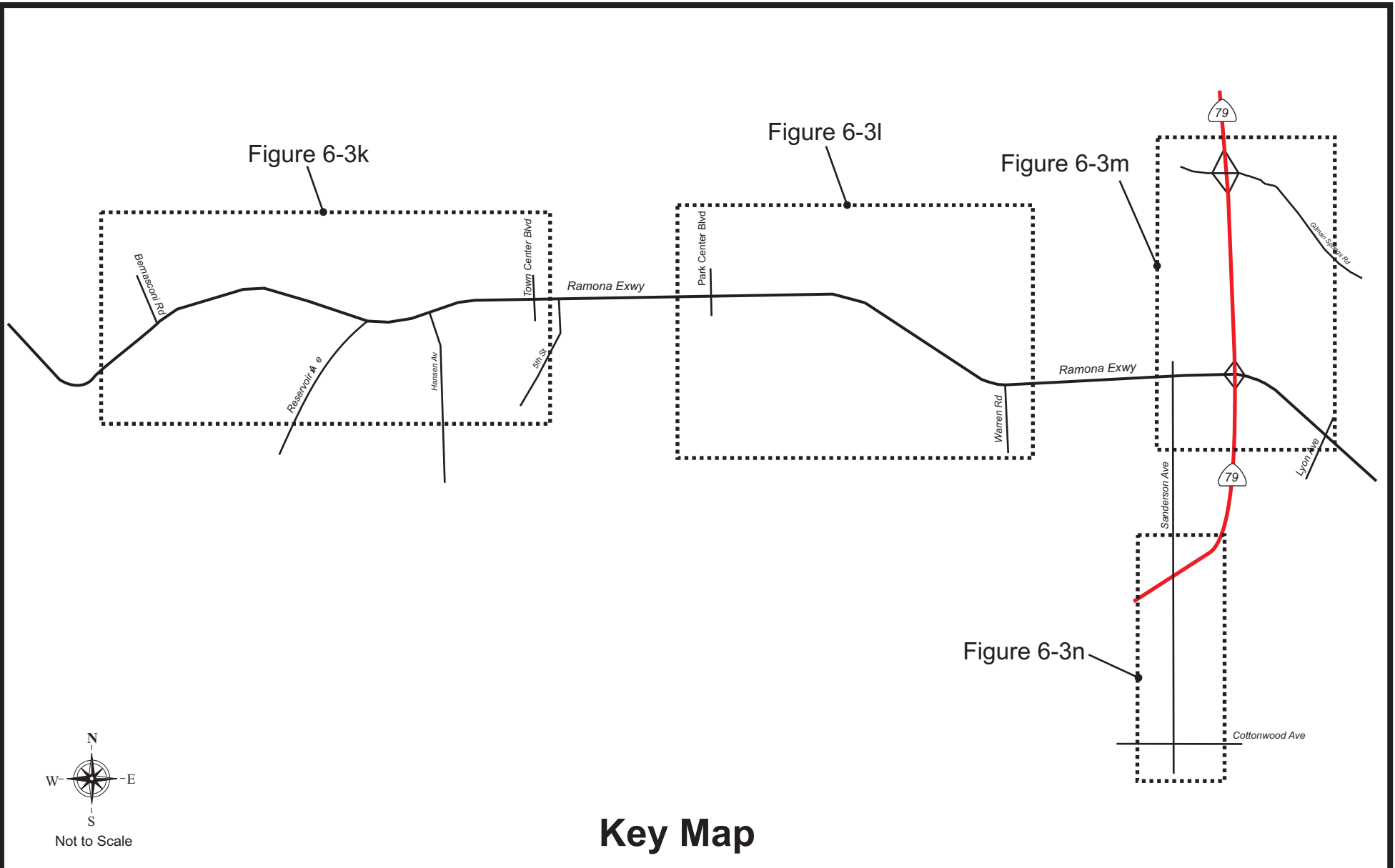

Key Map

**Horizon Year (2020) Intersection Lane Geometry
No Build**

Figure 6-3 (cont.)

Legend:

 Figure Areas



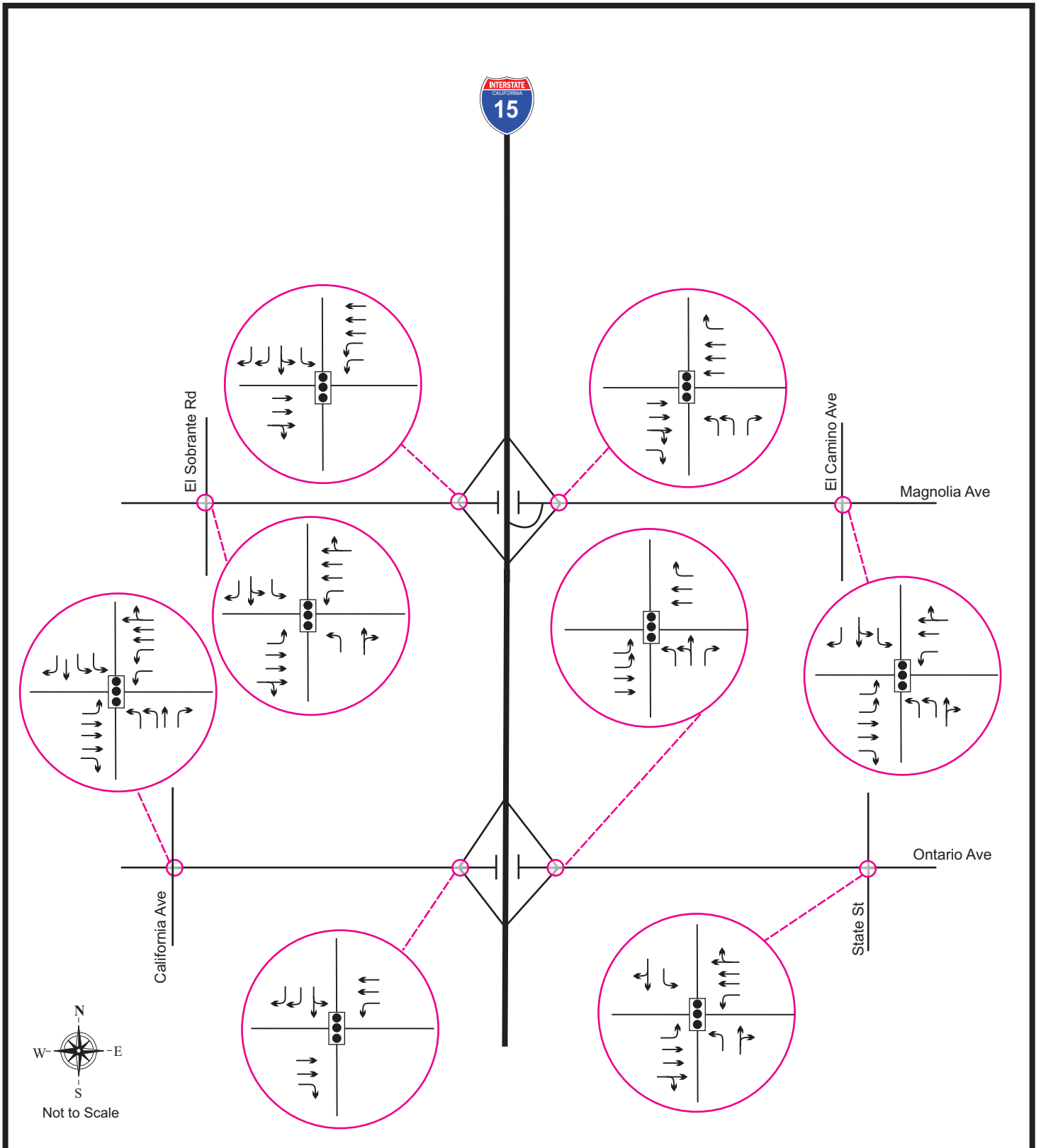

**Opening Year (2020) Intersection
Lane Geometry - No Build**

Figure 6-3a

Legend:



Signal



Traffic Lane



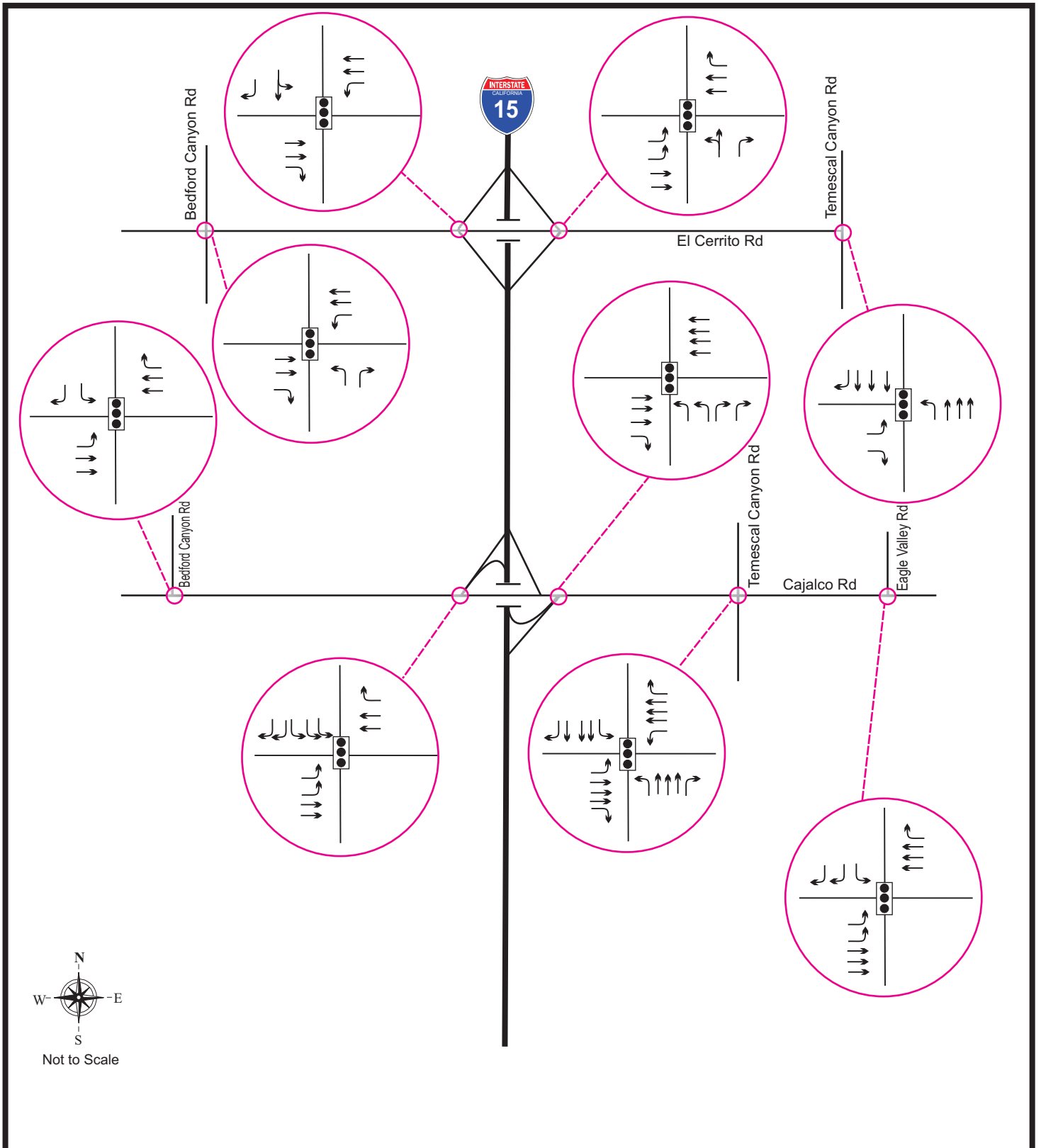

Opening Year (2020) Intersection Lane Geometry - No Build

Figure 6-3b

Legend:



Signal



Traffic Lane



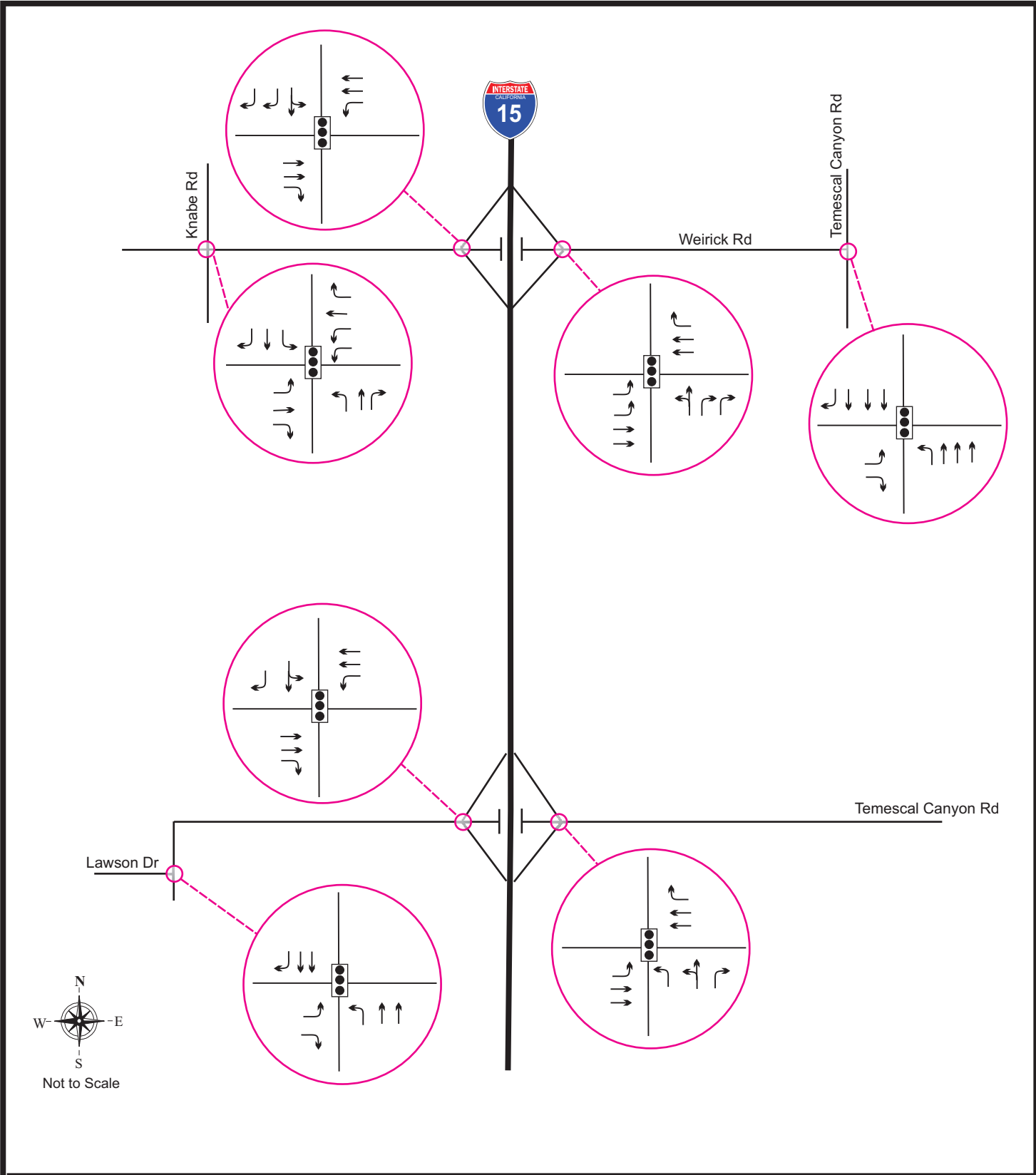

**Opening Year (2020) Intersection
Lane Geometry - No Build**

Figure 6-3c

Legend:



Signal



Traffic Lane



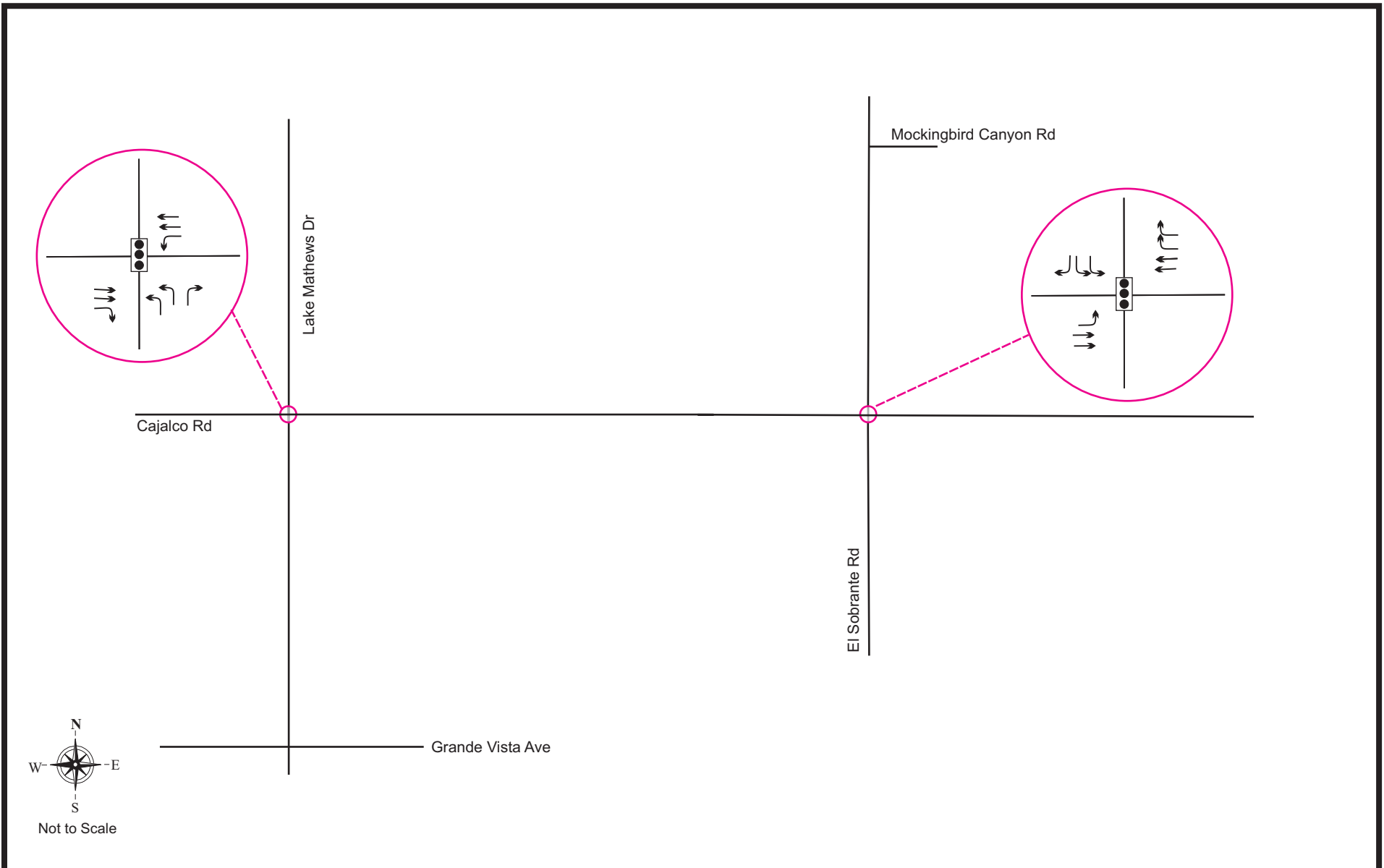

**Opening Year (2020) Intersection
Lane Geometry - No Build**

Figure 6-3d

Legend:

-  Signal
-  Traffic Lane



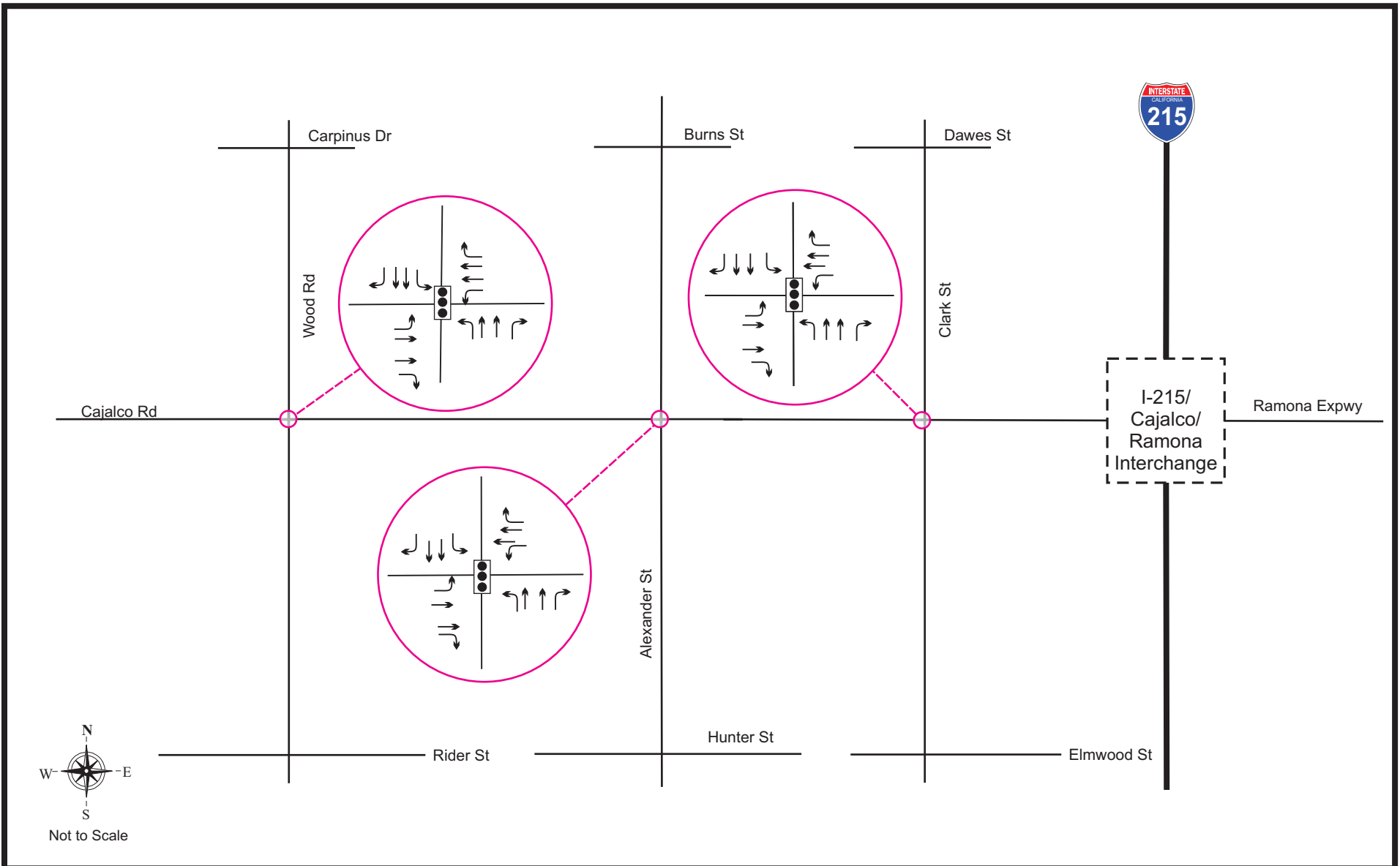

**Opening Year (2020) Intersection
Lane Geometry - No Build**

Figure 6-3e

Legend:

-  Signal
-  Traffic Lane



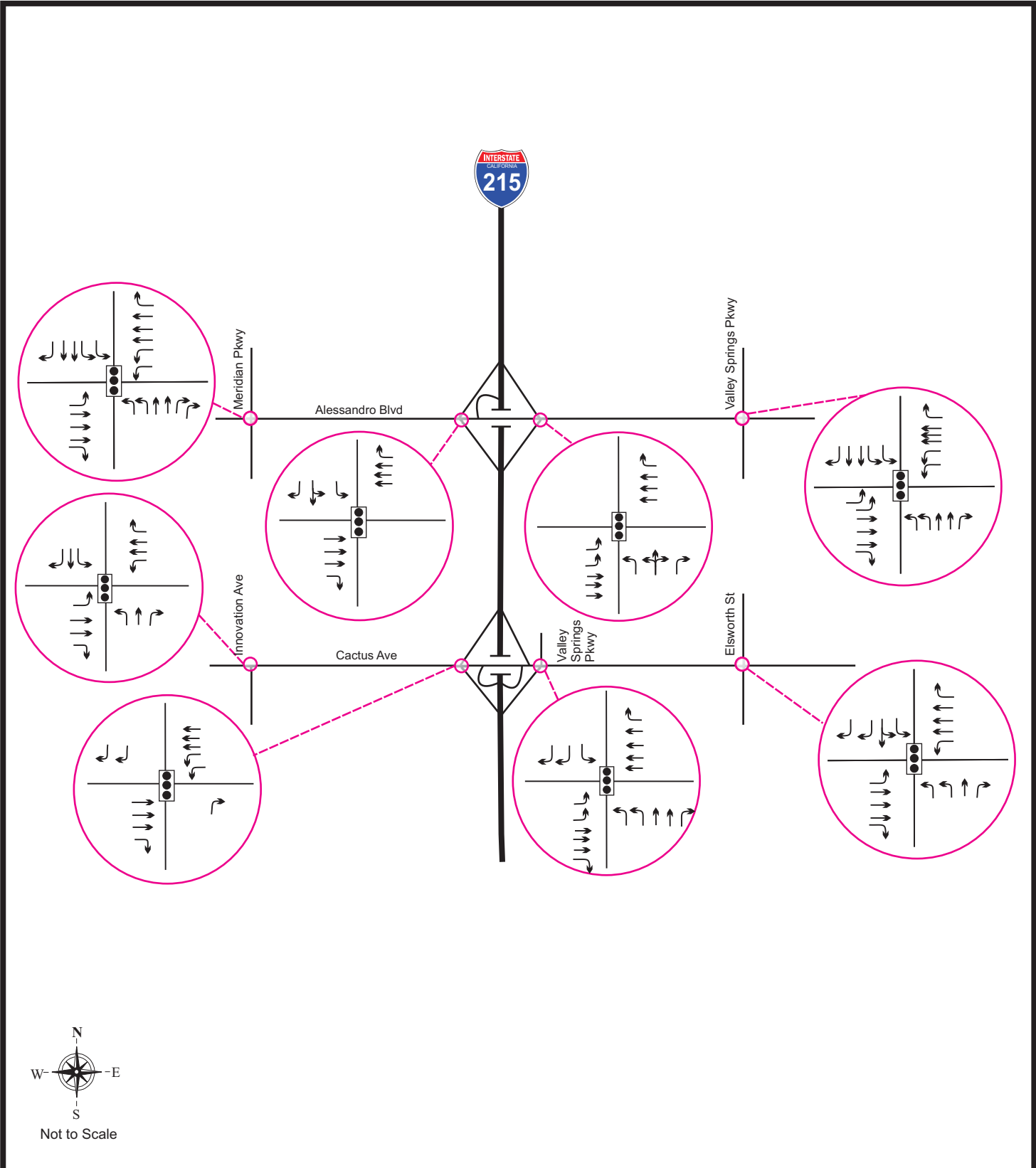

**Opening Year (2020) Intersection
Lane Geometry - No Build**

Figure 6-3f

Legend:



Signal



Traffic Lane



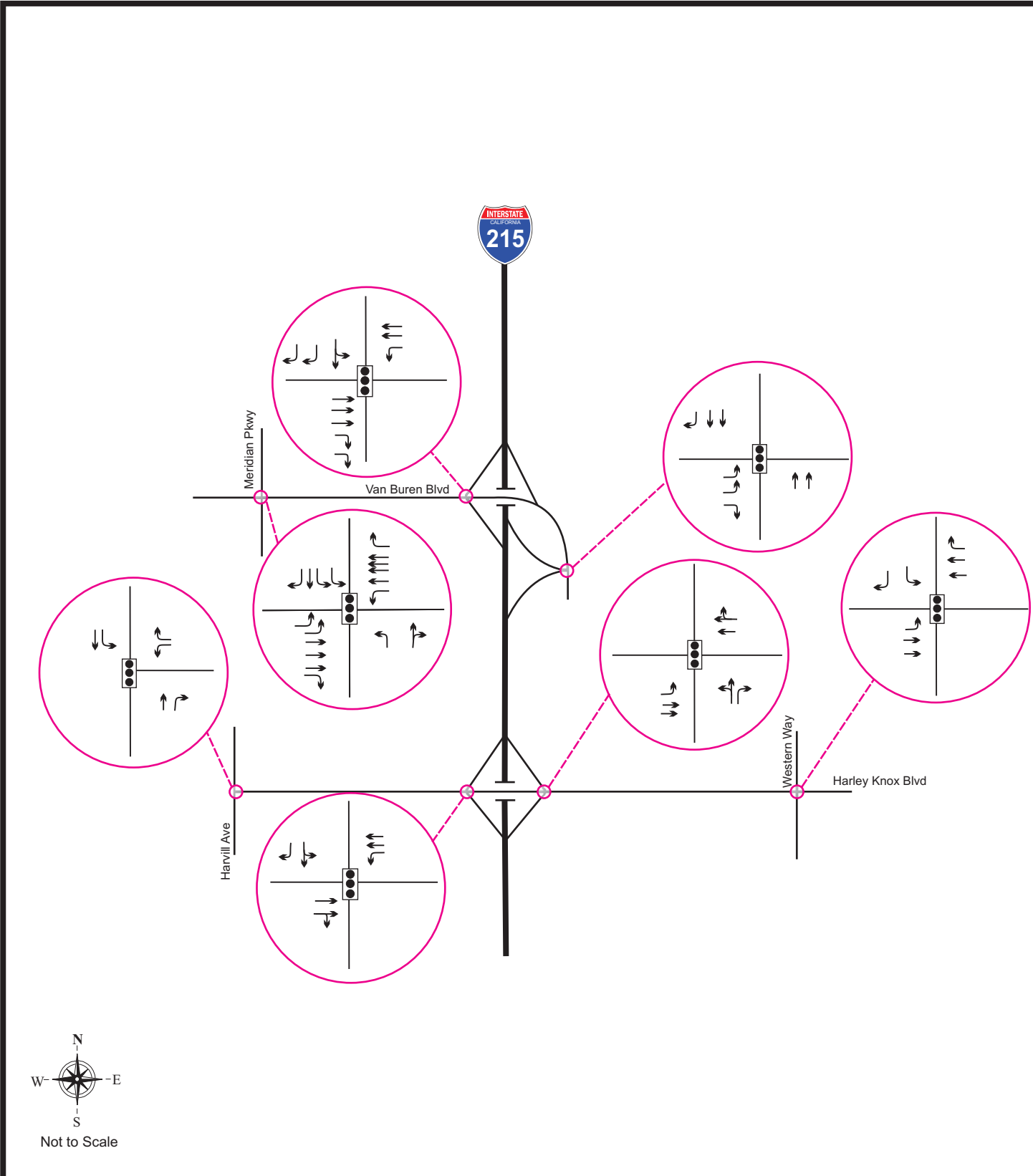

Opening Year (2020) Intersection Lane Geometry - No Build

Figure 6-3g

Legend:

-  Signal
-  Traffic Lane



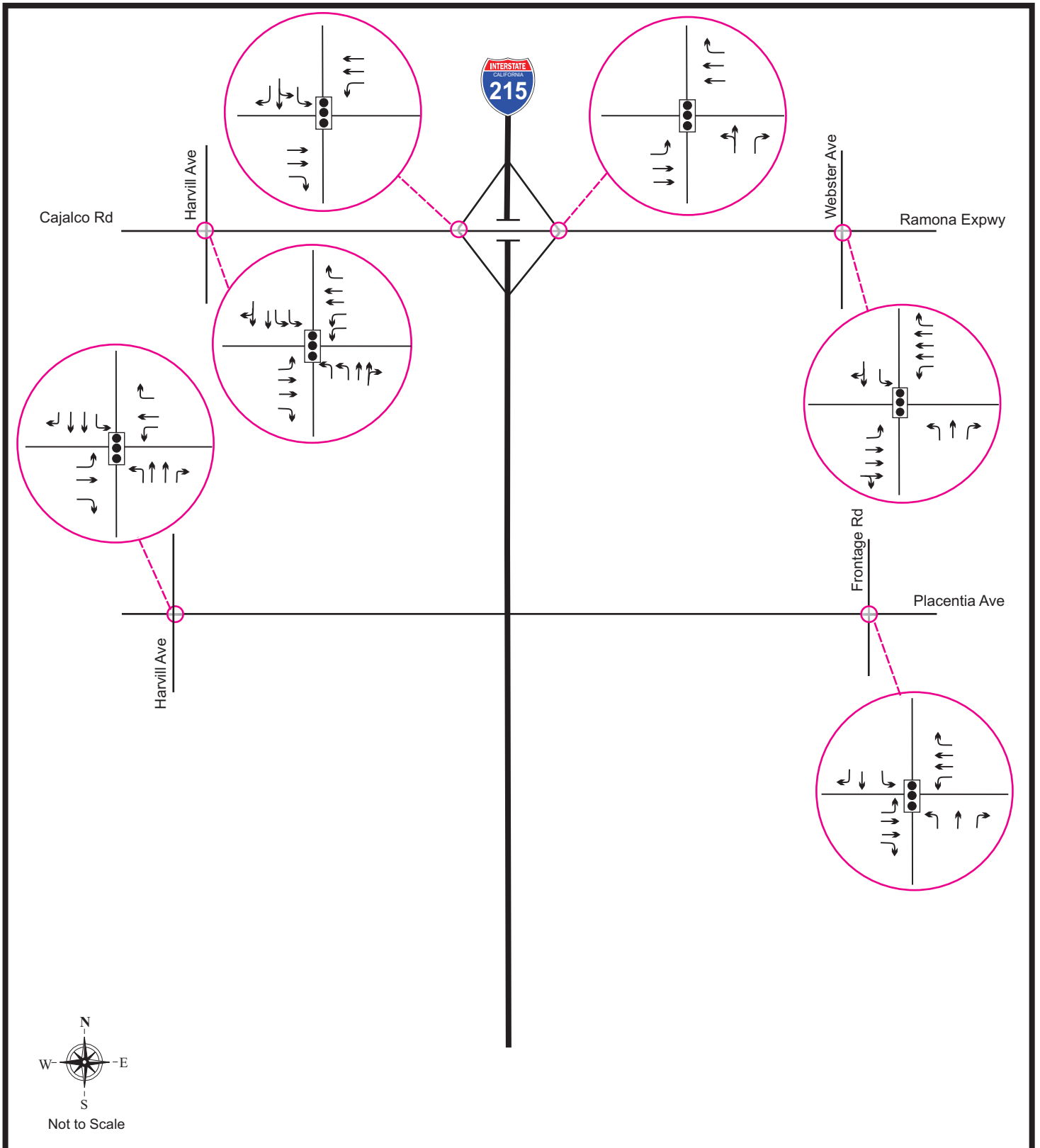

**Opening Year (2020) Intersection
Lane Geometry - No Build**

Figure 6-3h

Legend:



Signal



Traffic Lane



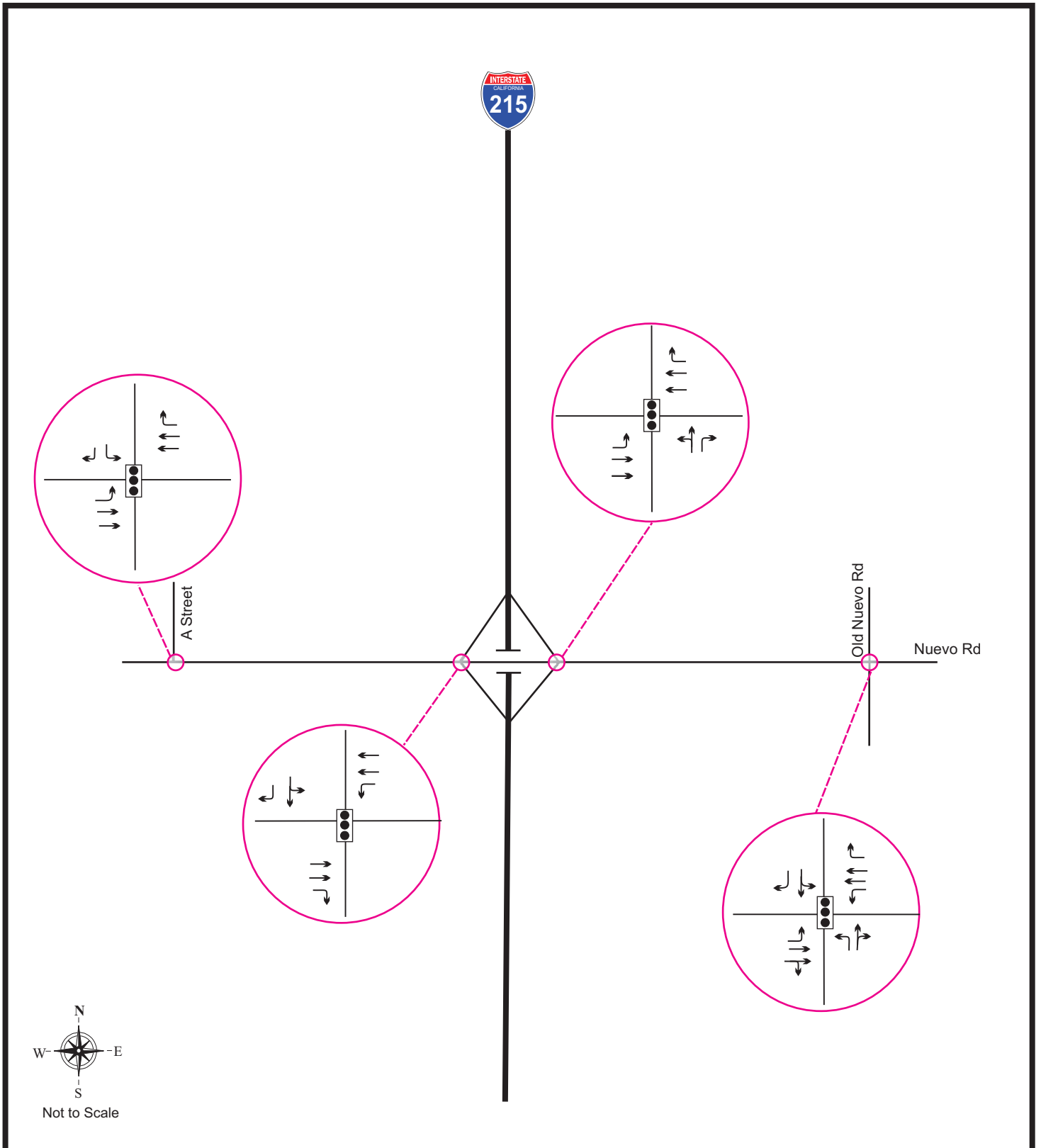

**Opening Year (2020) Intersection
Lane Geometry - No Build**

Figure 6-3i

Legend:



Signal



Traffic Lane



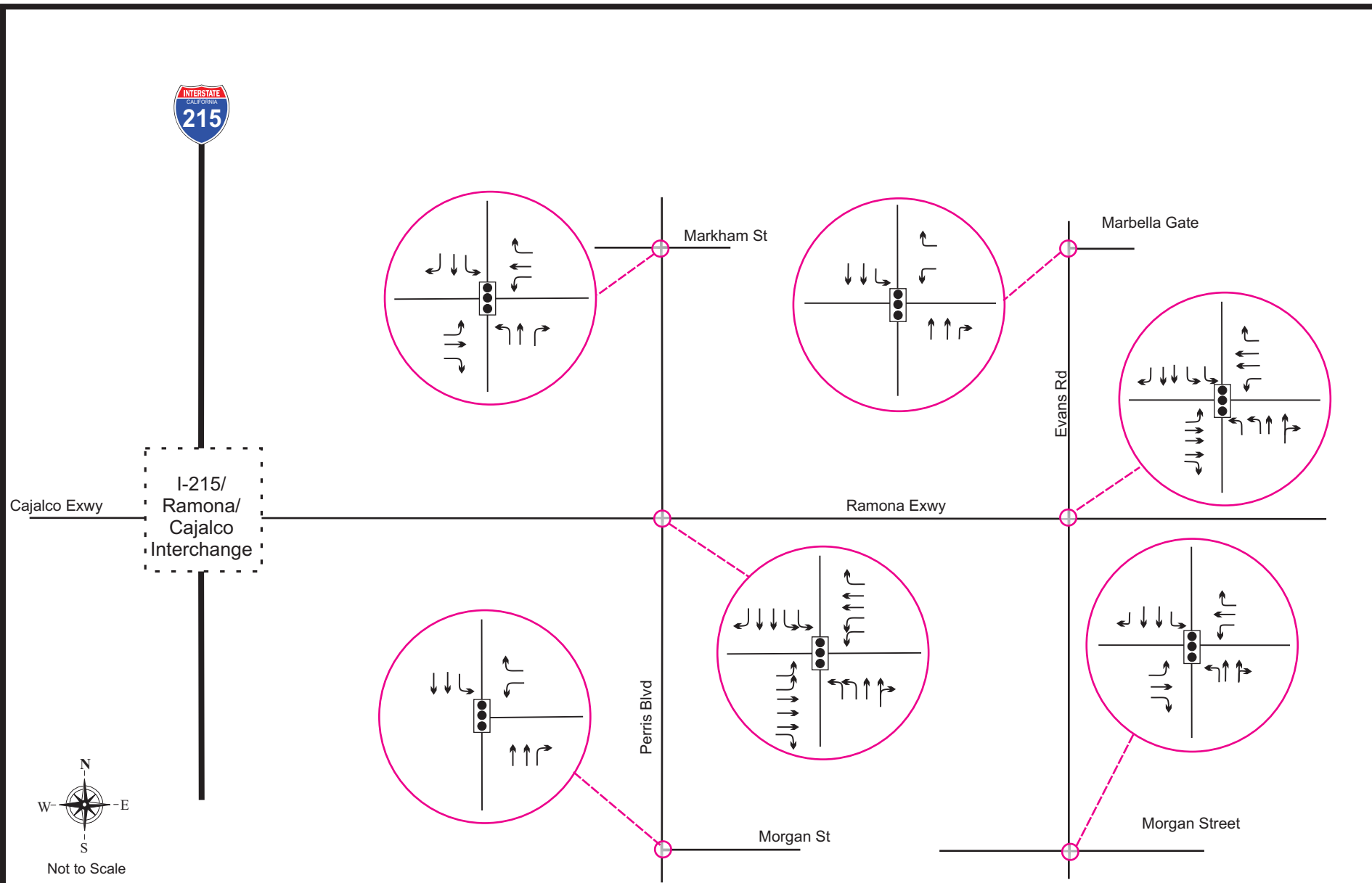

**Opening Year (2020) Intersection
Lane Geometry - No Build**

Figure 6-3j

Legend:

-  Signal
-  Traffic Lane



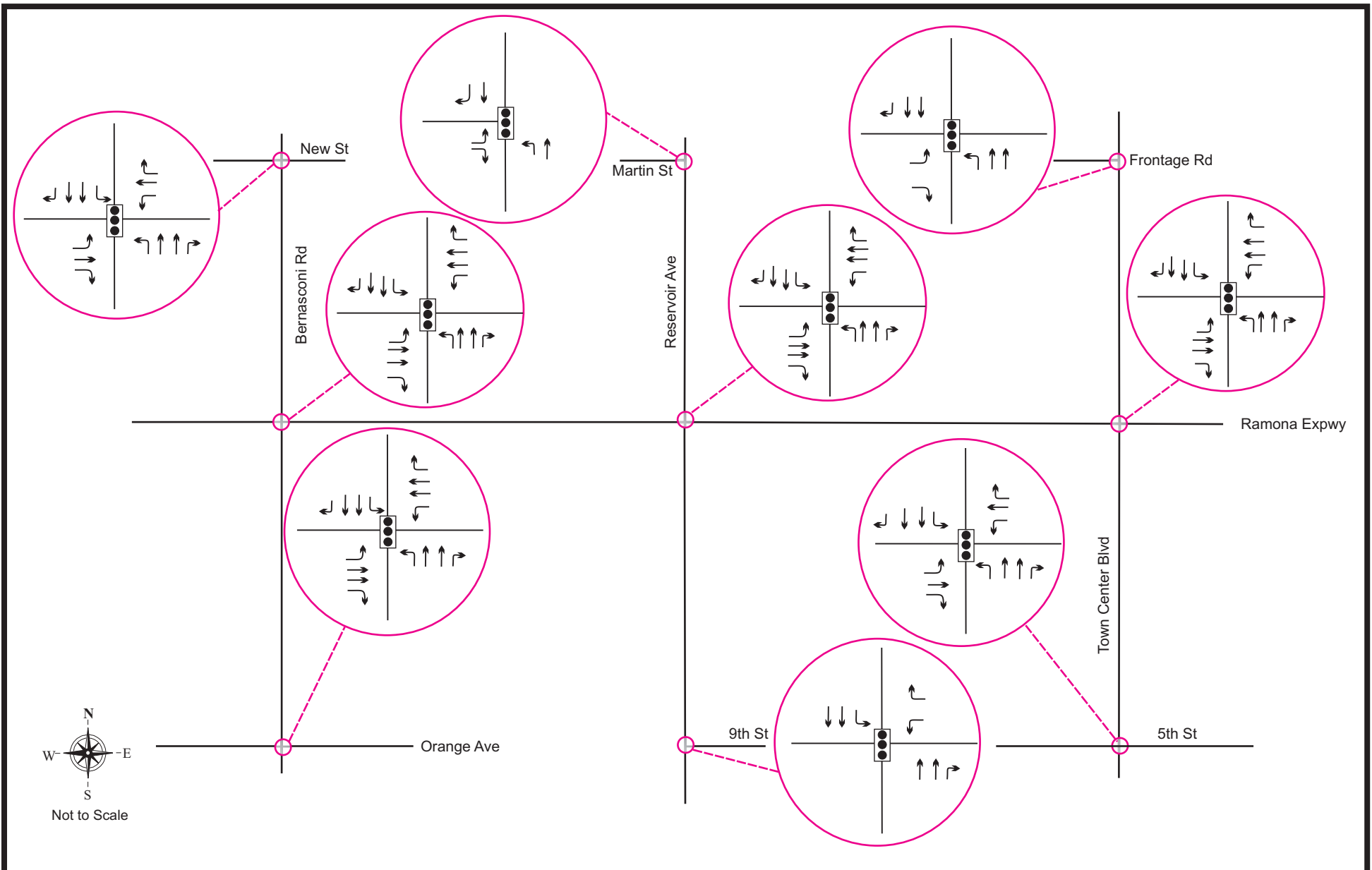

**Opening Year (2020) Intersection
Lane Geometry - No Build**

Figure 6-3k

Legend:



Signal



Traffic Lane



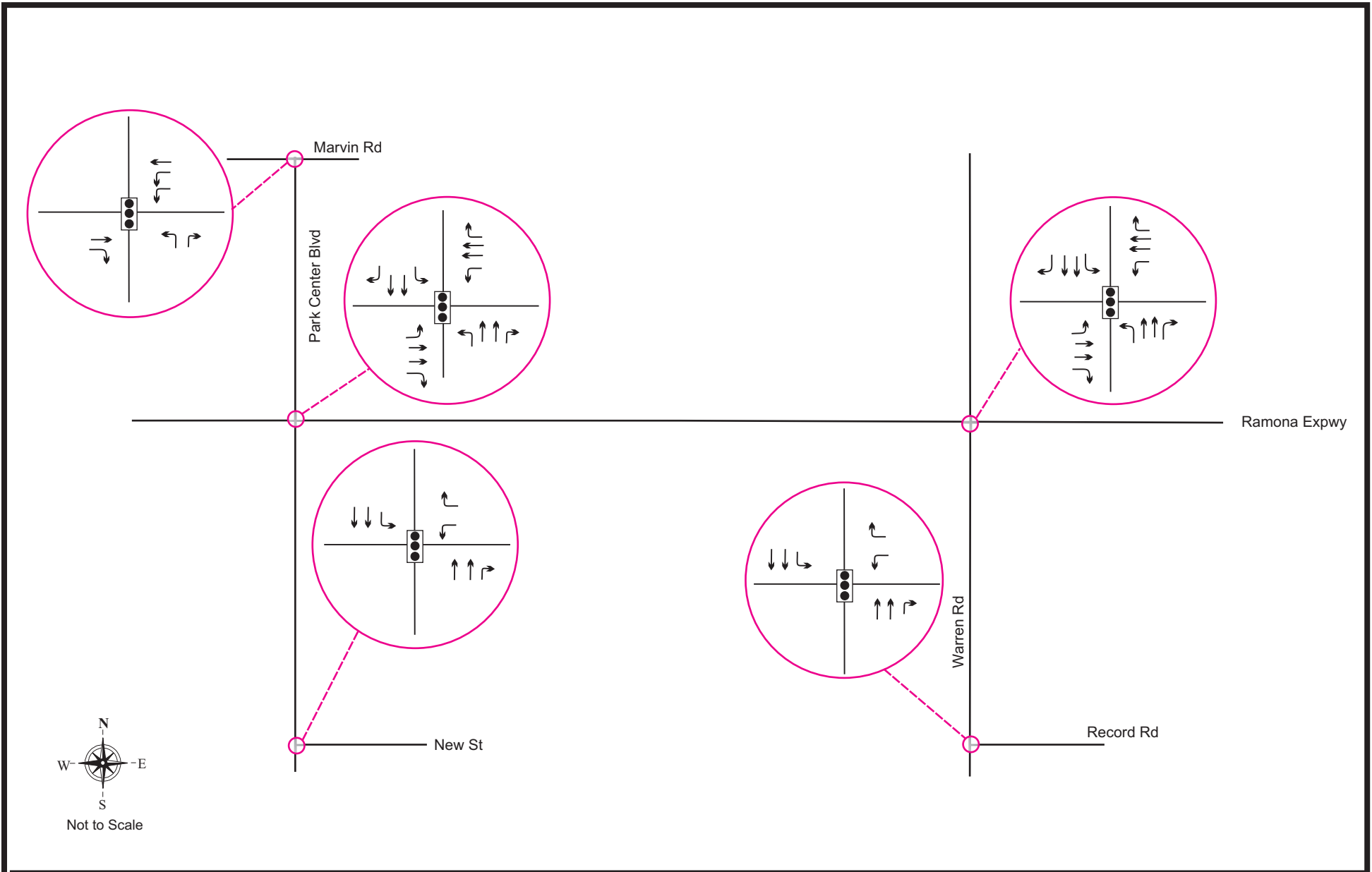

**Opening Year (2020) Intersection
Lane Geometry - No Build**

Figure 6-3I

Legend:

-  Signal
-  Traffic Lane



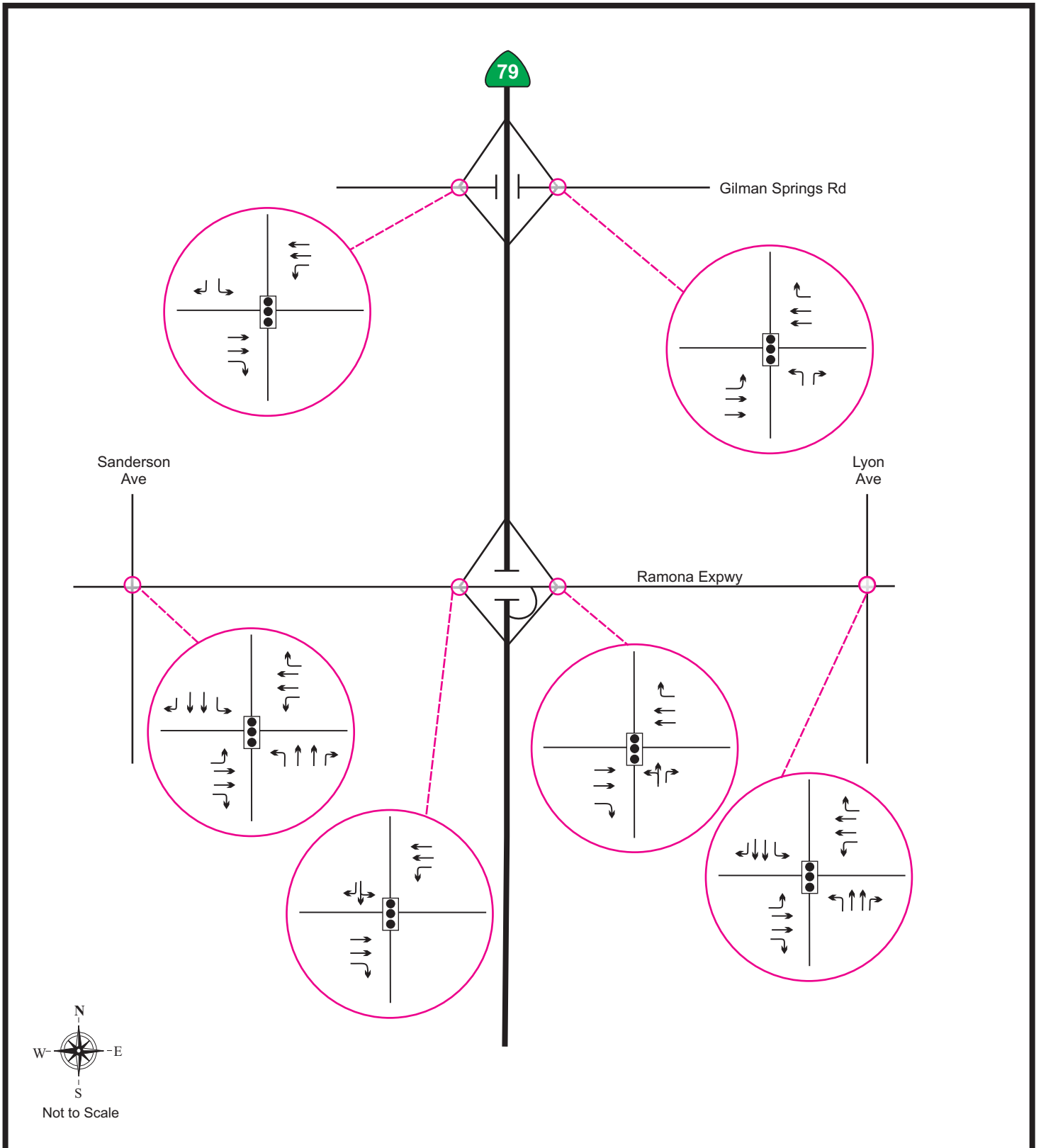

Opening Year (2020) Intersection Lane Geometry - No Build

Figure 6-3m

Legend:



Signal



Traffic Lane



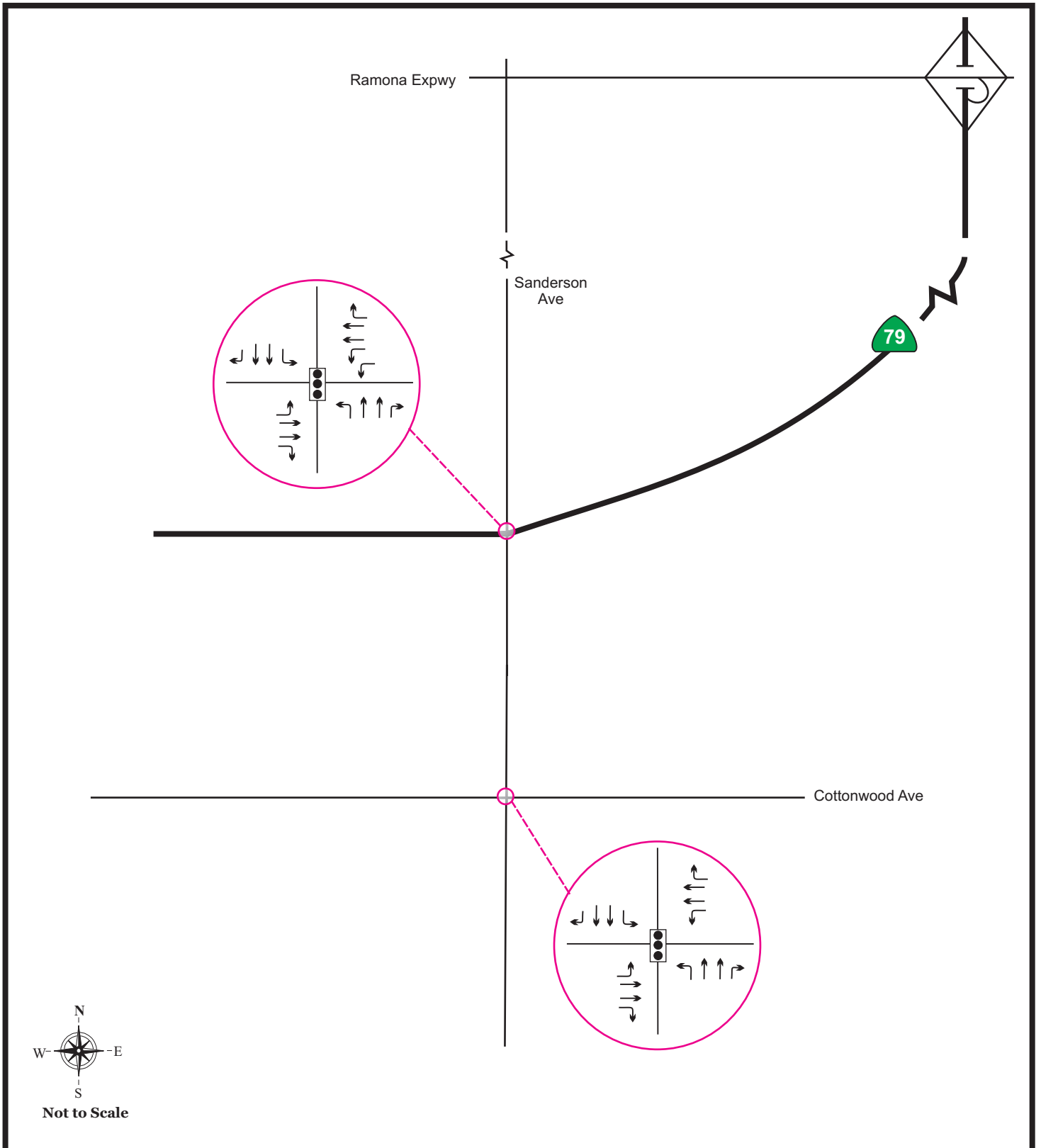

**Opening Year (2020) Intersection
Lane Geometry - No Build**

Figure 6-3n

Legend:



Signal



Traffic Lane



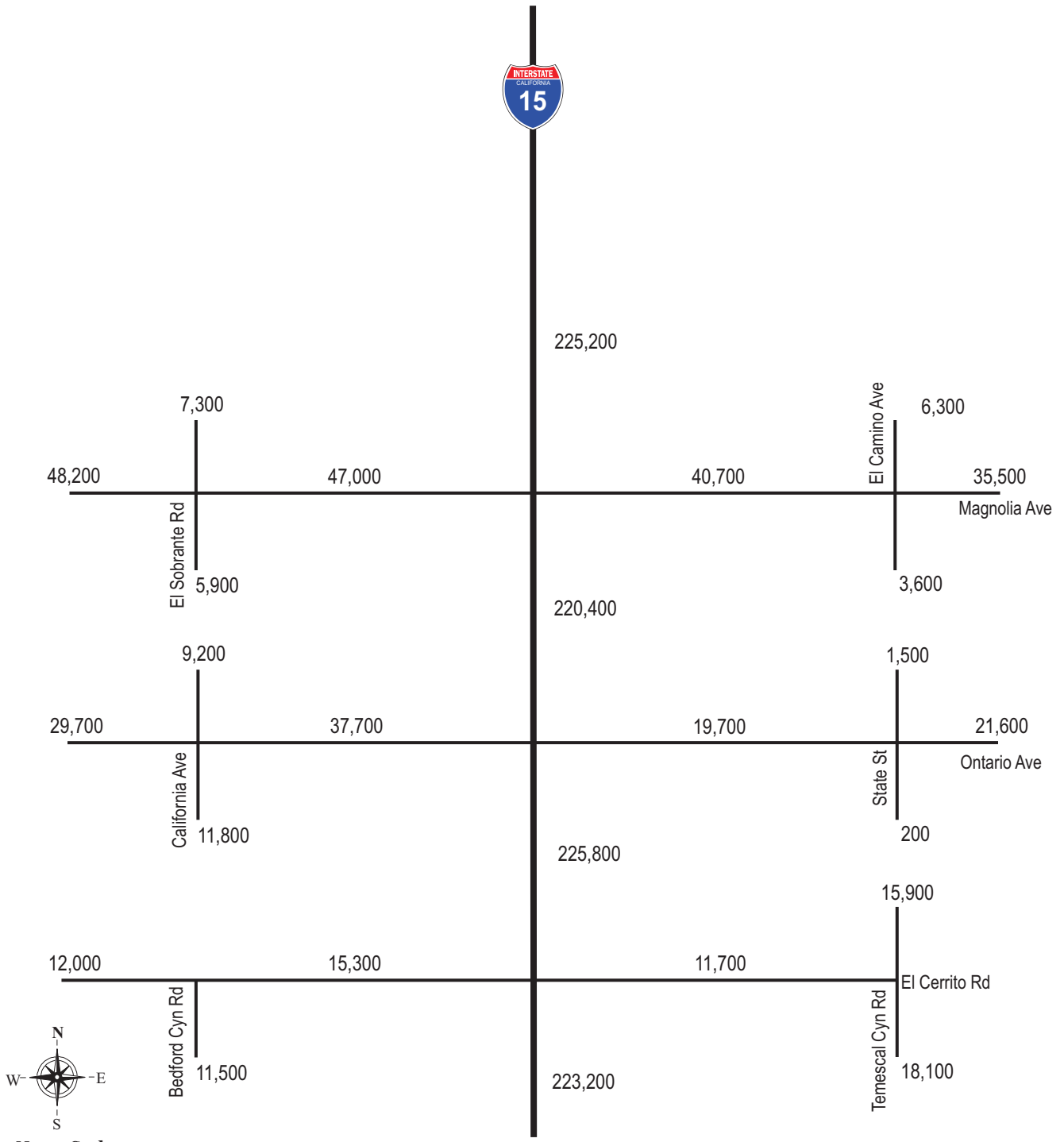

Not to Scale

Opening Year (2020) ADT - Freeway and Street Segments MCP Area - No Build

Figure 6-4a

Legend:

XX,XXX Average Daily Traffic



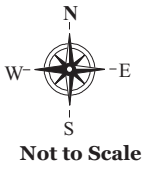
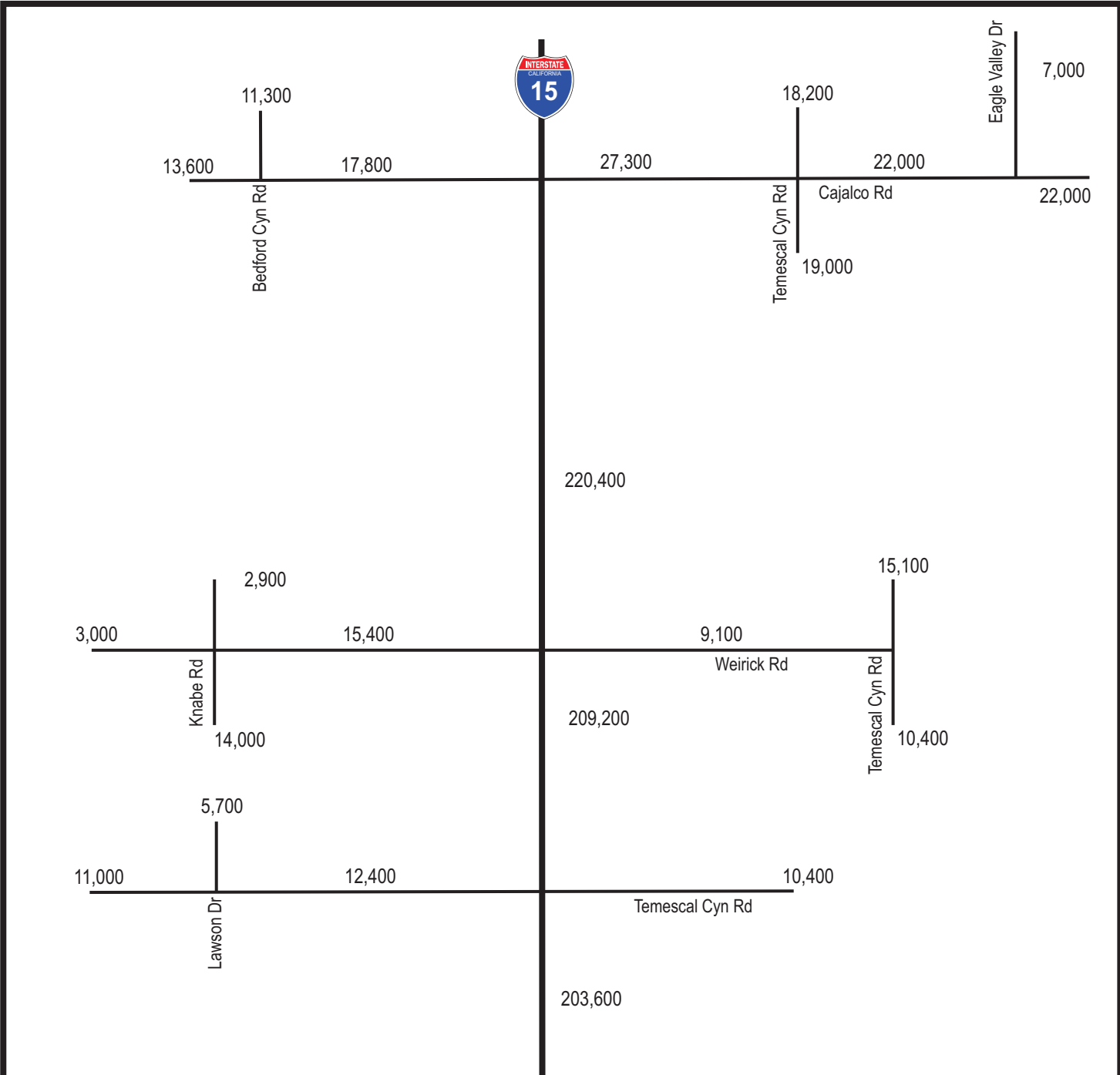

Opening Year (2020) ADT - Freeway and Street Segments MCP Area - No Build

Figure 6-4b

Legend:
XX,XXX Average Daily Traffic



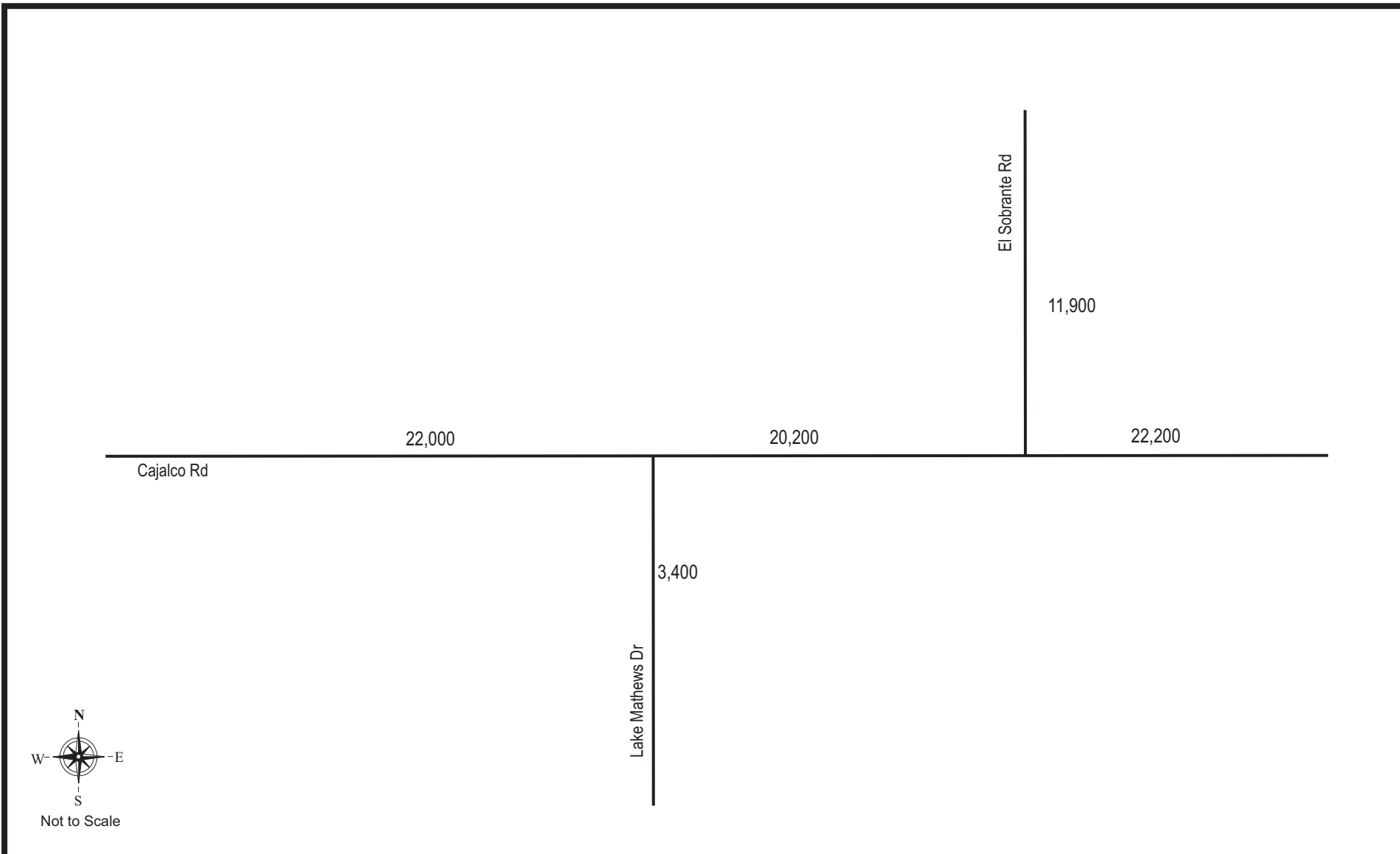

Opening Year (2020) ADT - Freeway and Street Segments MCP Area - No Build

Figure 6-4c

Legend:

XX,XXX Average Daily Traffic



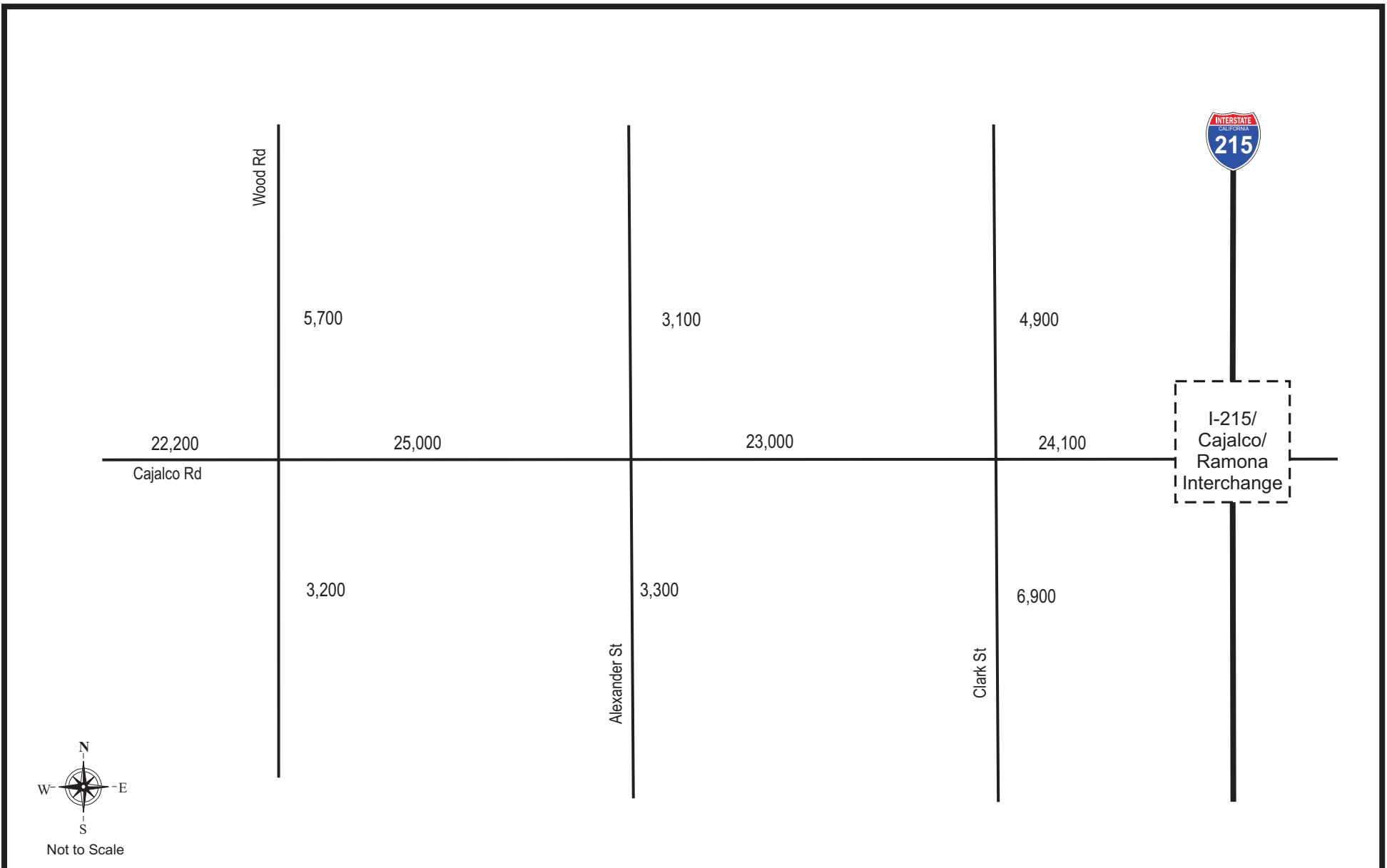

Opening Year (2020) ADT - Freeway and Street Segments MCP Area - No Build

Figure 6-4d

Legend:

XX,XXX Average Daily Traffic



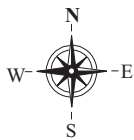
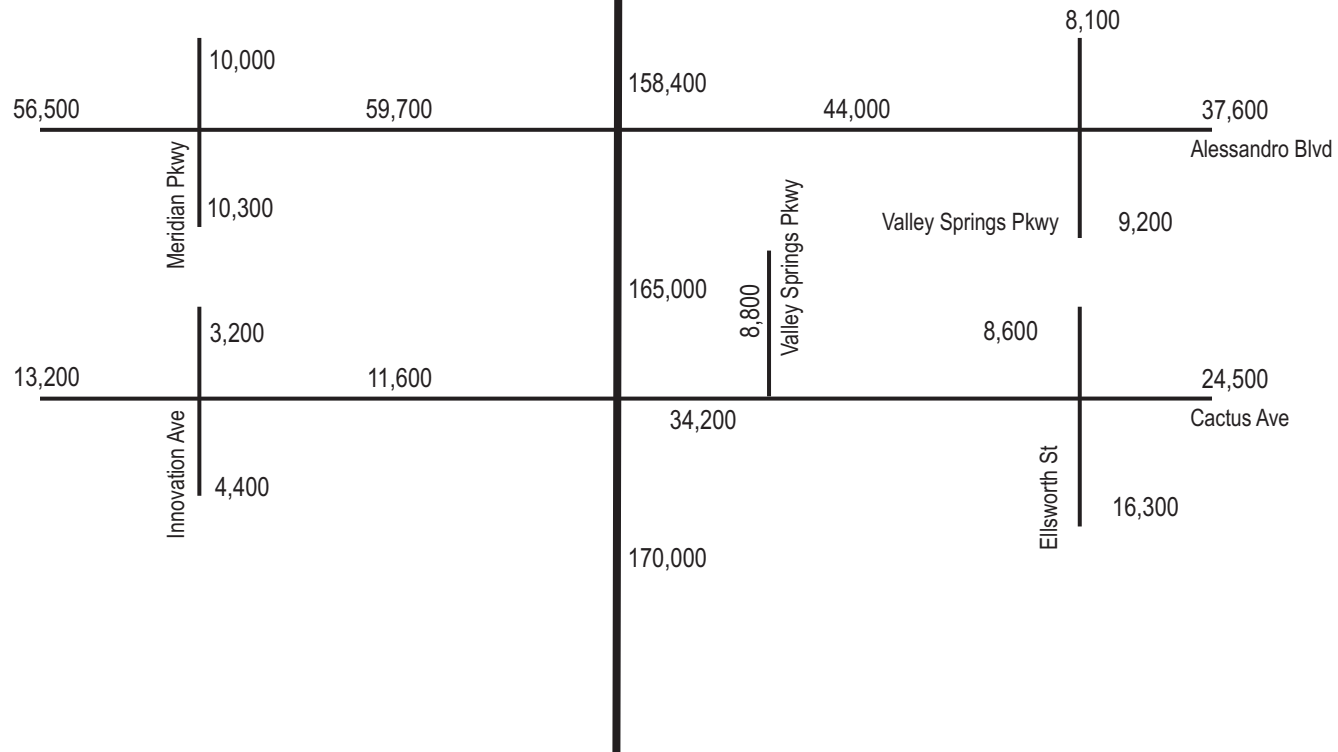

Not to Scale

Opening Year (2020) ADT - Freeway and Street Segments MCP Area - No Build

Figure 6-4e

Legend:

XX,XXX Average Daily Traffic





Not to Scale

Opening Year (2020) ADT - Freeway and Street Segments MCP Area - No Build

Figure 6-4f

Legend:

XX,XXX Average Daily Traffic



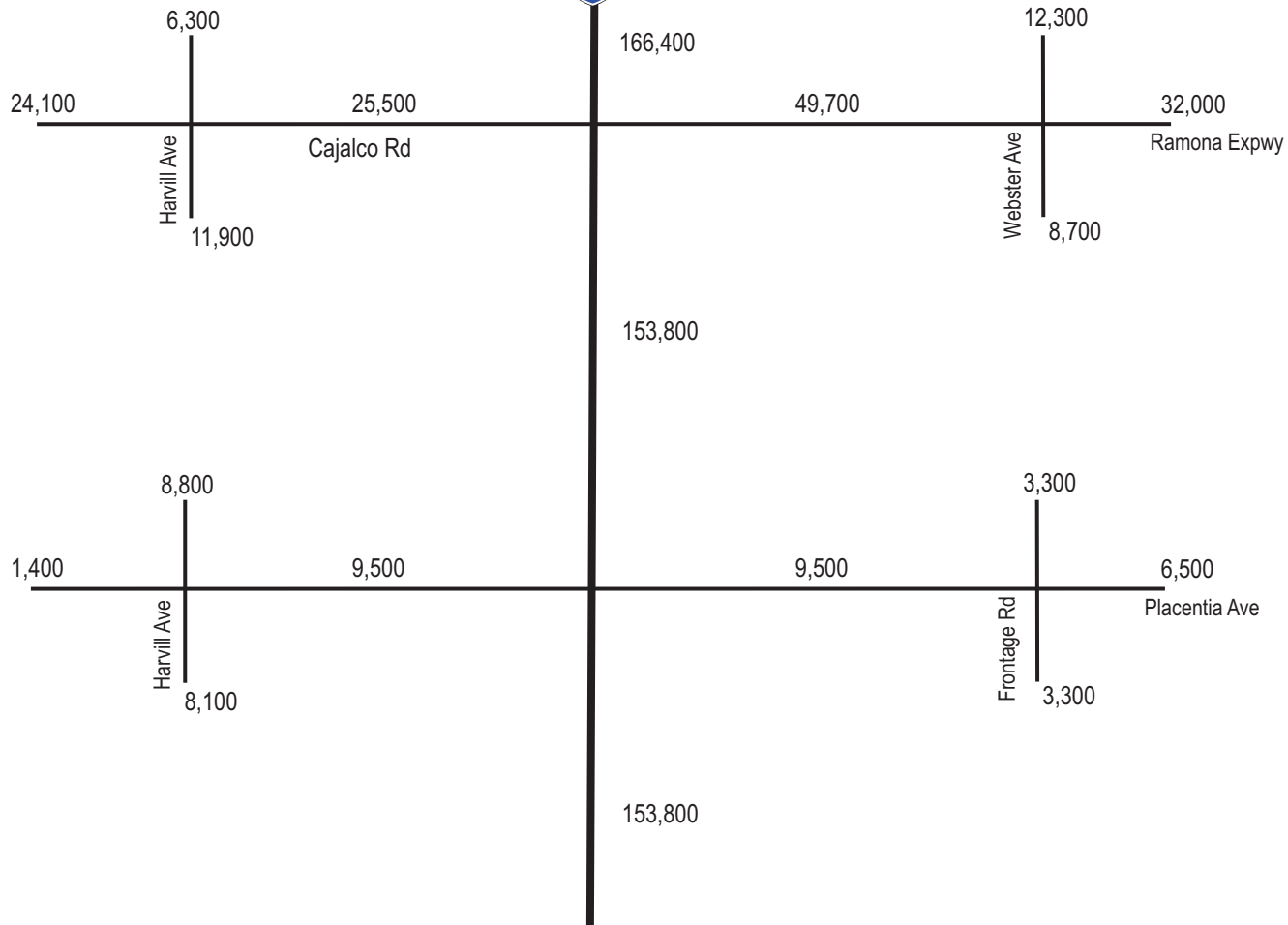

Opening Year (2020) ADT - Freeway and Street Segments MCP Area - No Build

Figure 6-4g

Legend:

XX,XXX Average Daily Traffic





Not to Scale

Opening Year (2020) ADT - Freeway and Street Segments MCP Area - No Build

Figure 6-4h

Legend:

XX,XXX Average Daily Traffic



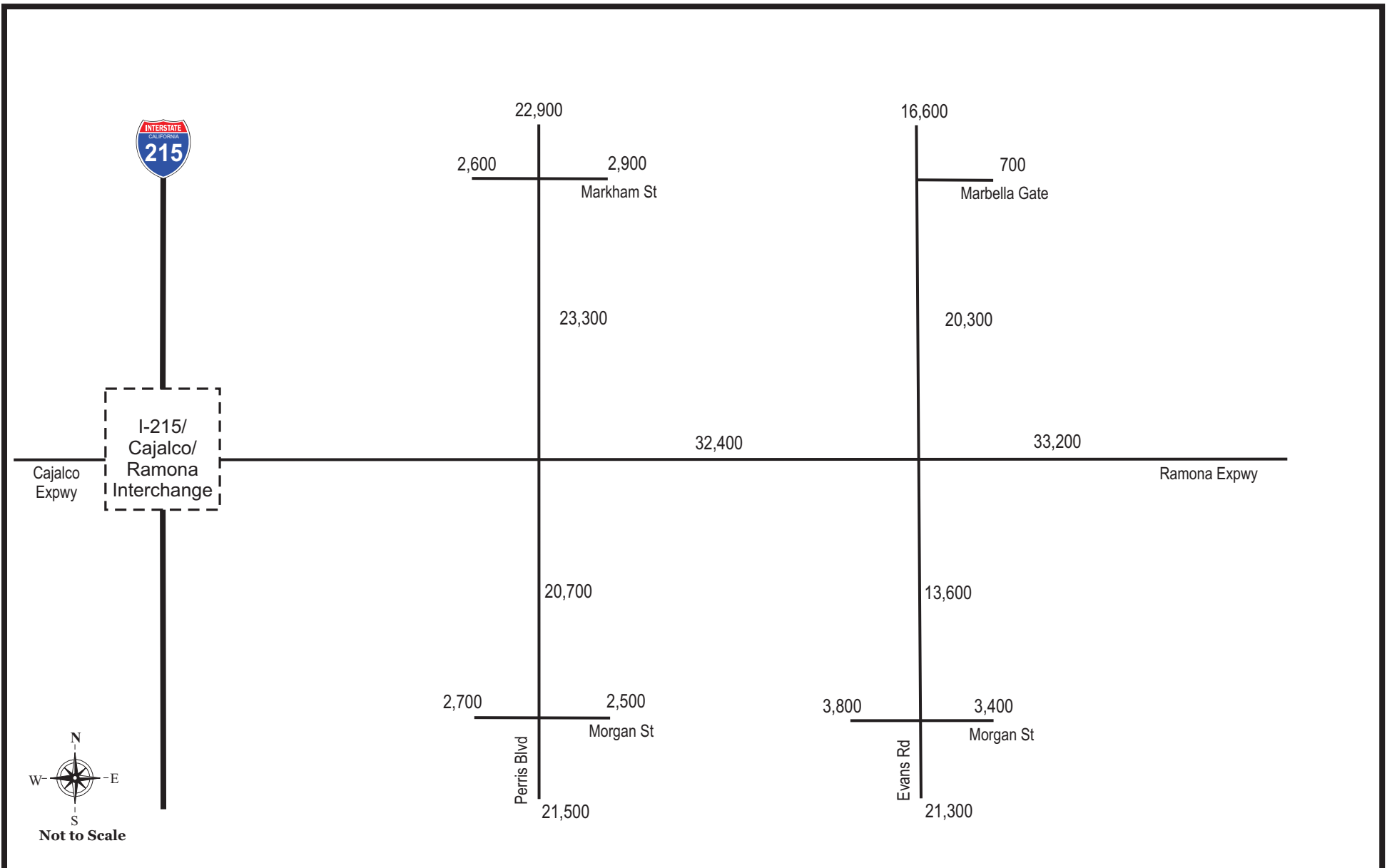

Opening Year (2020) ADT - Freeway and Street Segments MCP Area - No Build

Figure 6-4i

Legend:

XX,XXX Average Daily Traffic



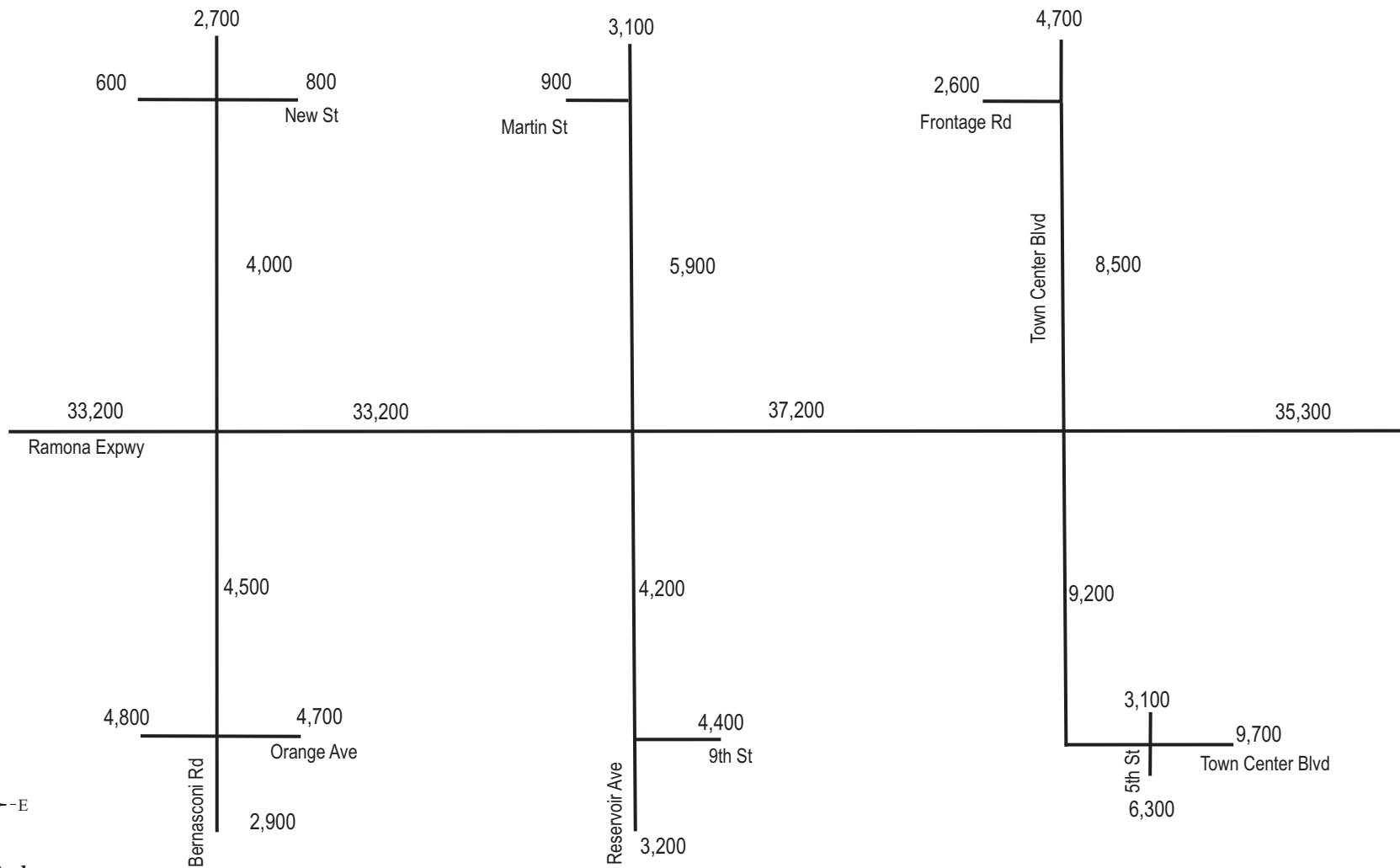

Opening Year (2020) ADT - Freeway and Street Segments MCP Area - No Build

Figure 6-4j

Legend:

XX,XXX Average Daily Traffic



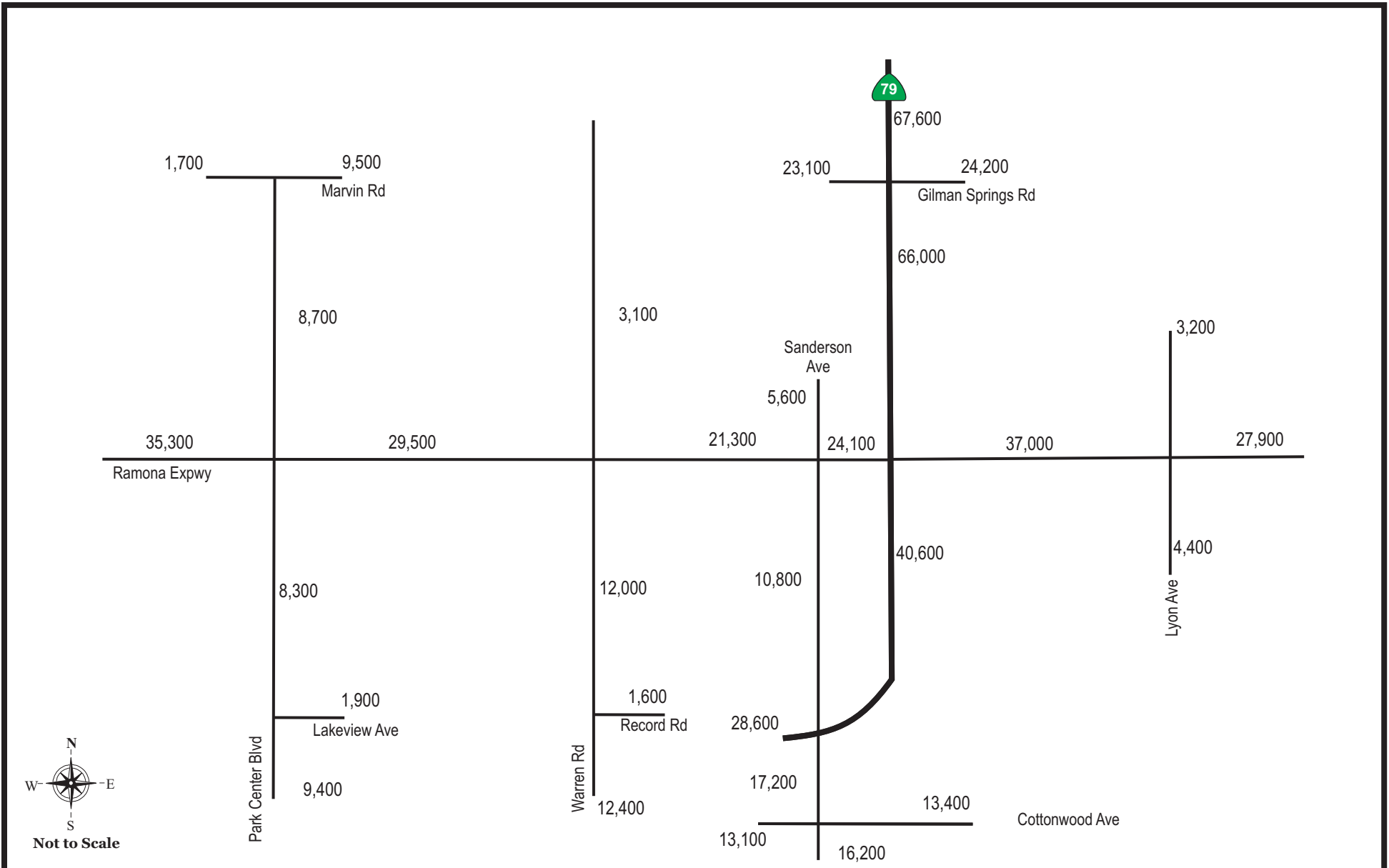

Opening Year (2020) ADT - Freeway and Street Segments MCP Area - No Build

Figure 6-4k

Legend:

XX,XXX Average Daily Traffic



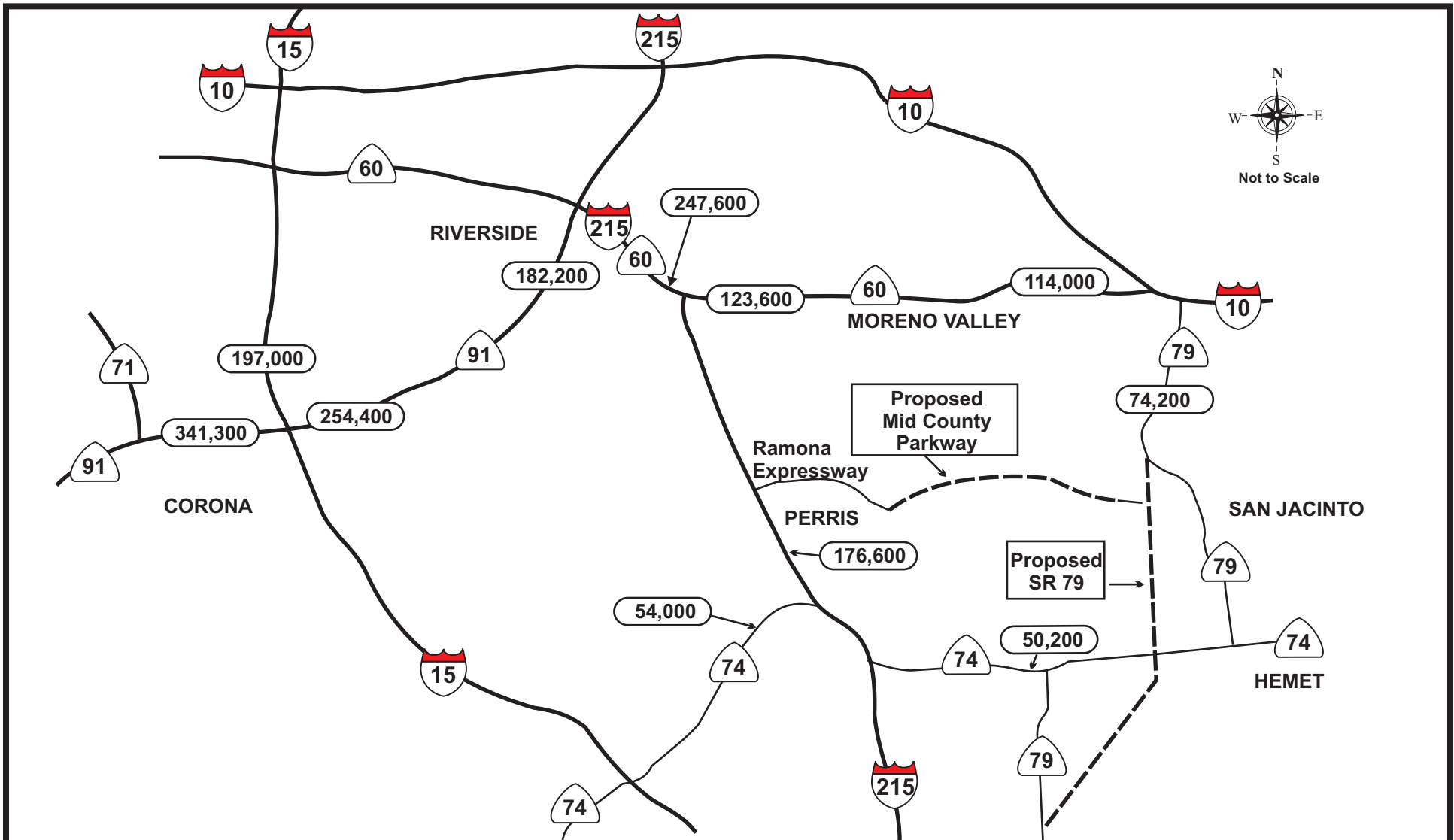

Opening Year (2020) ADT Freeway and Street Segments Outside MCP Area - No Build

Figure 6-5

Legend

- Existing Limited Access Roadway
- Existing Arterial Roadway
- - - Proposed Limited Access Roadway
- (XXX,XXX) Average Daily Traffic



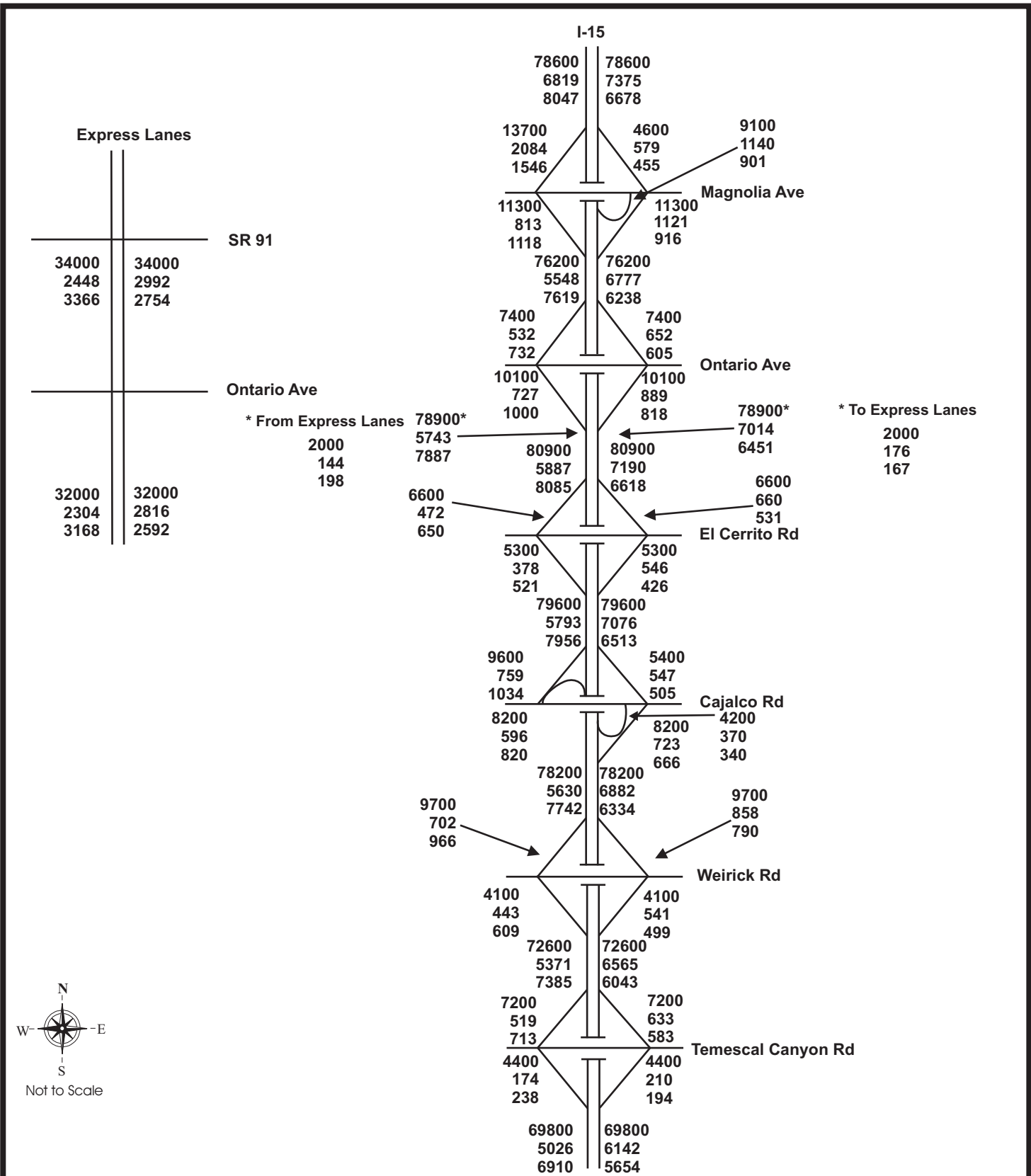

**Opening Year (2020) Freeway and Ramp Traffic
Interstate 15 - No Build**

Figure 6-6

Legend

- XXXXXX ADT
- XXXX AM Peak Hour
- XXXX PM Peak Hour



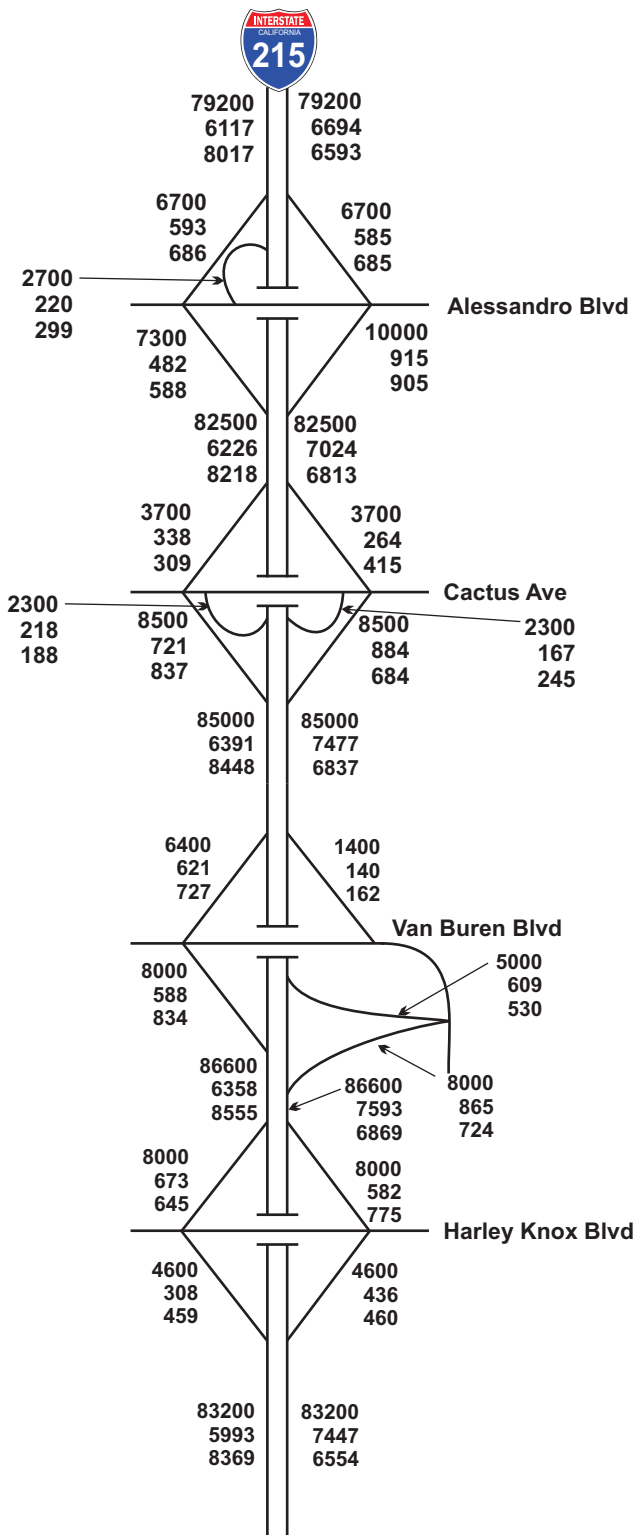

**Opening Year (2020)
Freeway and Ramp Traffic
Interstate 215 - No Build**

Figure 6-7a

Legend

- XXXXX Average Daily Traffic
- XXX AM Peak Hour Traffic
- XXX PM Peak Hour Traffic



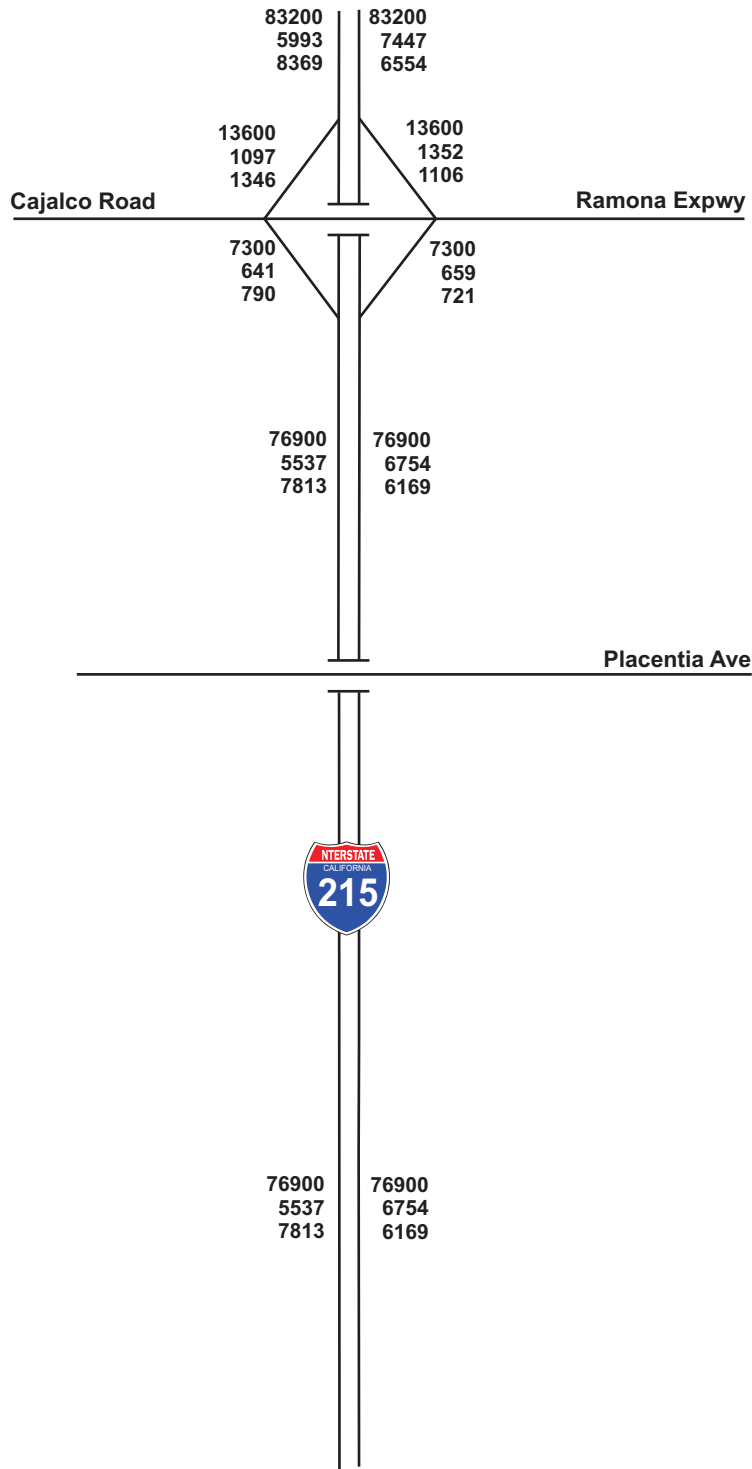

Not to Scale

**Opening Year (2020)
Freeway and Ramp Traffic
Interstate 215 - No Build**

Figure 6-7b

Legend

- XXXXX Average Daily Traffic
- XXX AM Peak Hour Traffic
- XXX PM Peak Hour Traffic



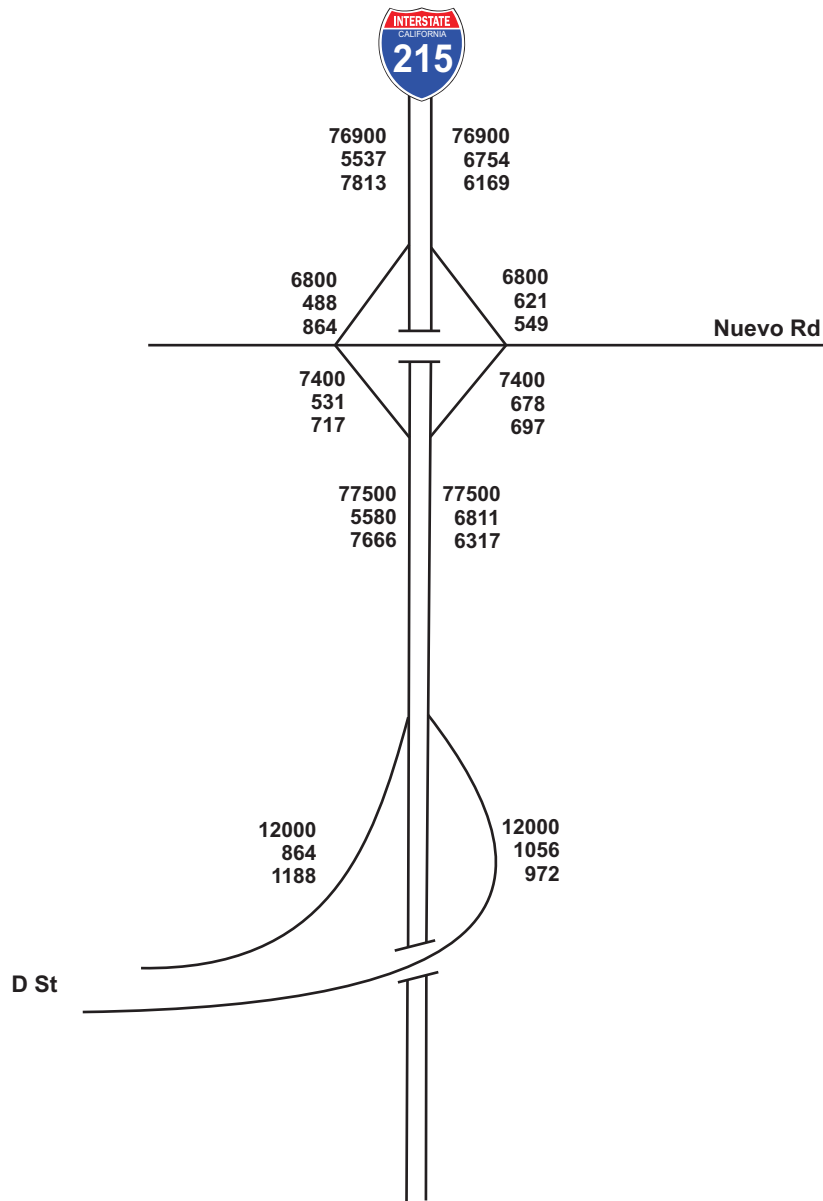

**Opening Year (2020)
Freeway and Ramp Traffic
Interstate 215 - No Build**

Figure 6-7c

Legend

- XXXXX Average Daily Traffic
- XXX AM Peak Hour Traffic
- XXX PM Peak Hour Traffic



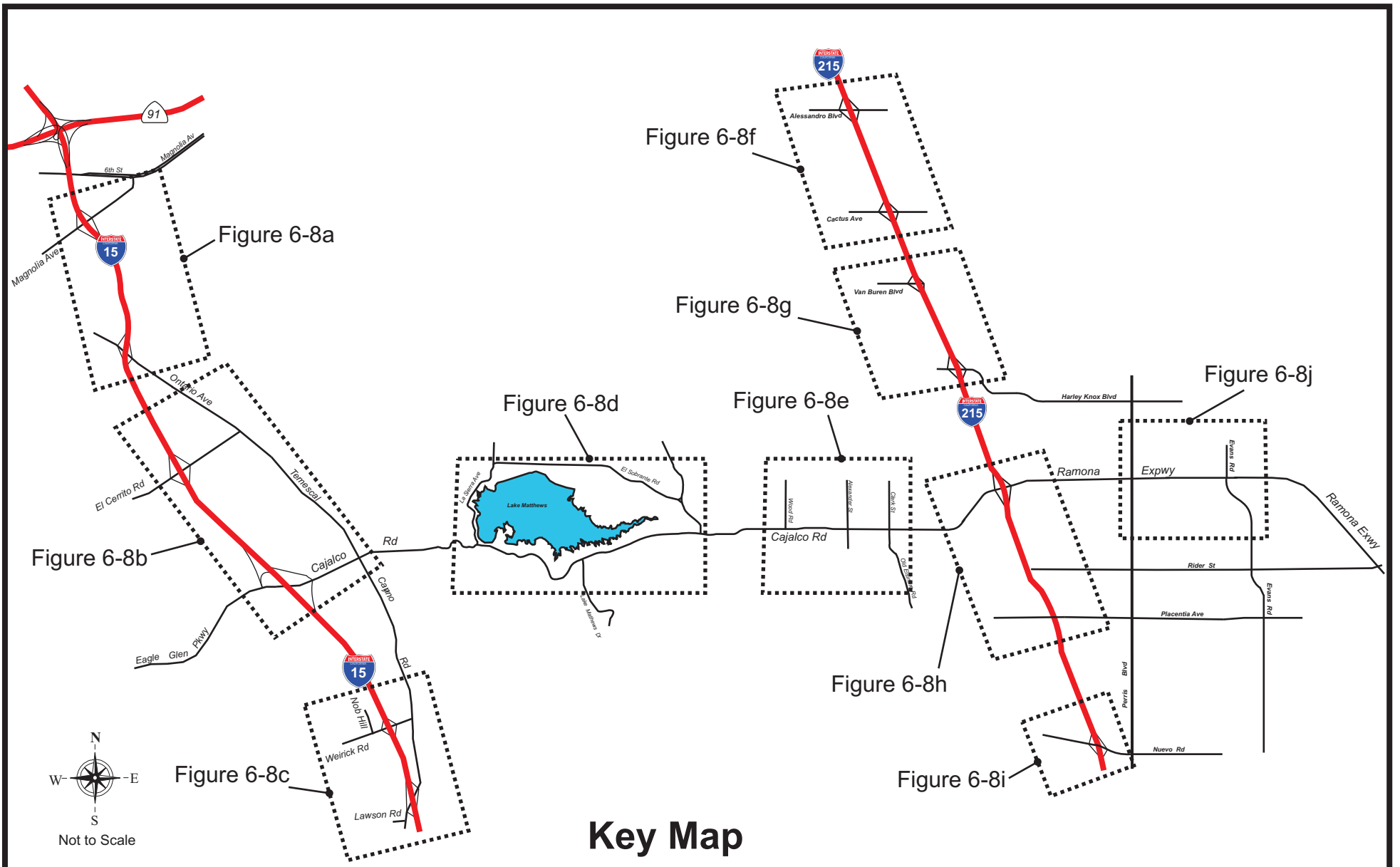

**Horizon Year (2020) AM/PM Peak Hour Traffic - Intersections
No Build**

Figure 6-8



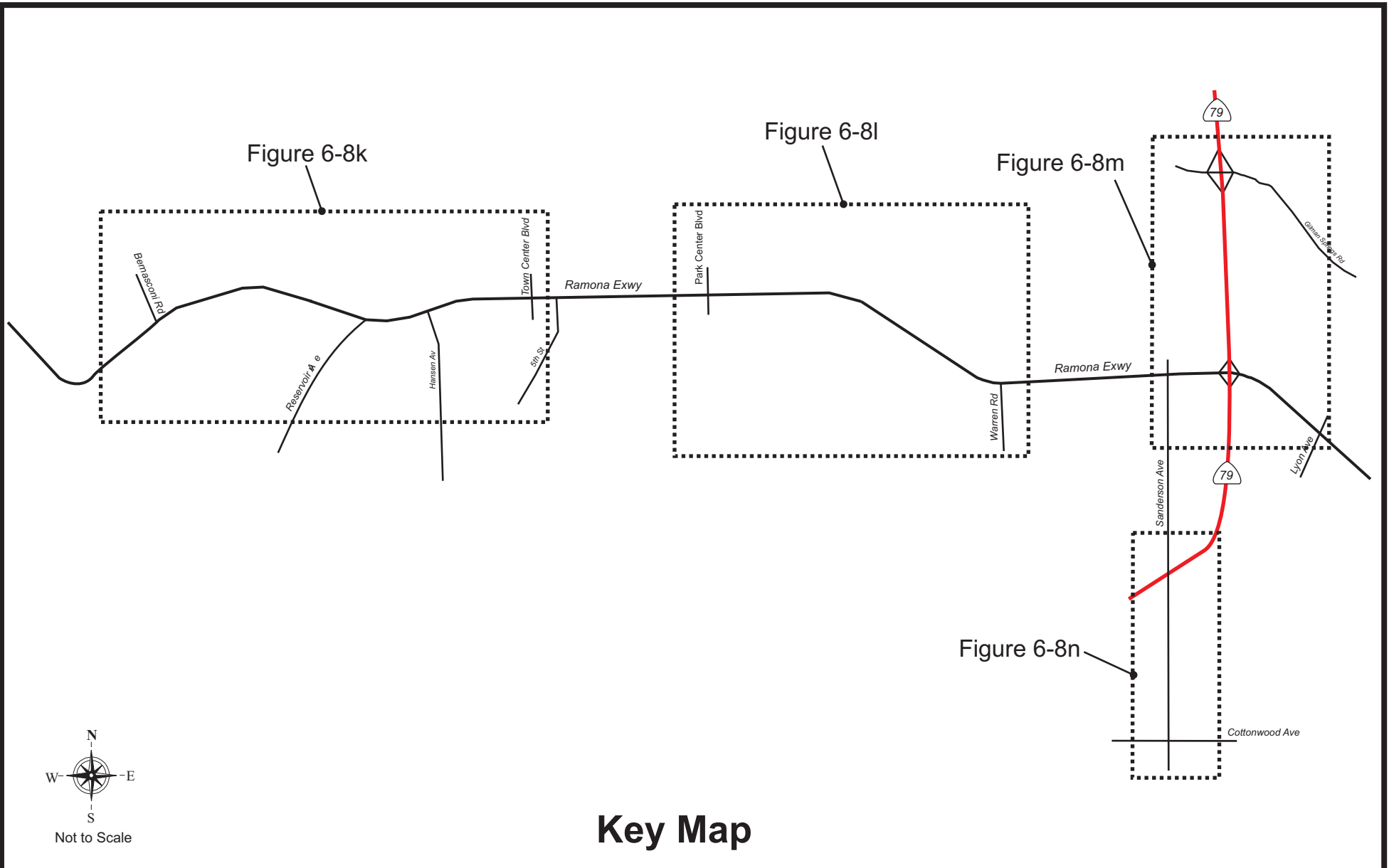

Key Map

**Horizon Year (2020) AM/PM Peak Hour Traffic - Intersections
No Build**

Figure 6-8 (cont.)

Legend:

 Figure Areas



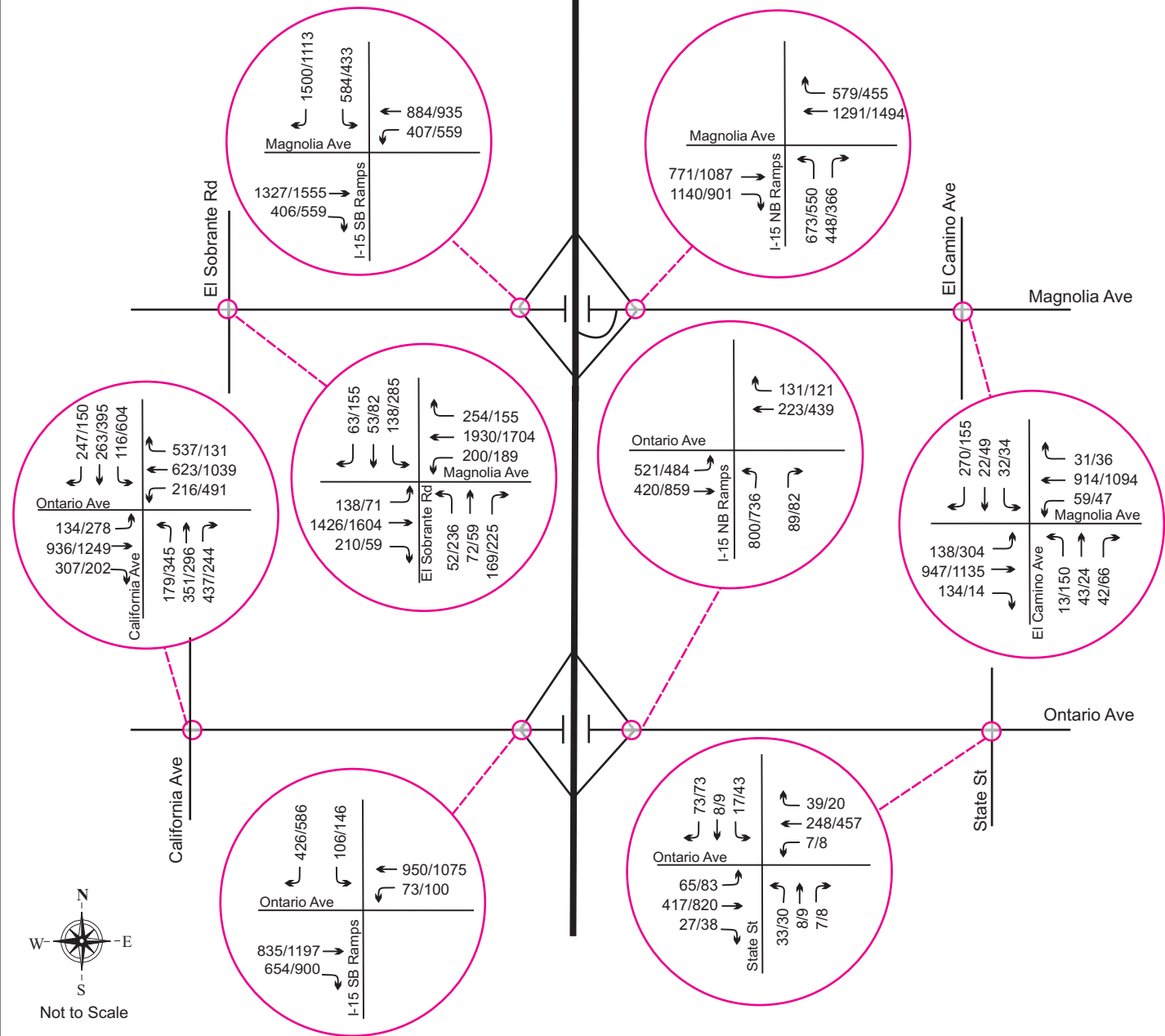

Opening Year (2020) AM/PM Peak Hour Traffic Intersections - No Build

Figure 6-8a

XXX/XXX AM/PM Peak Hour



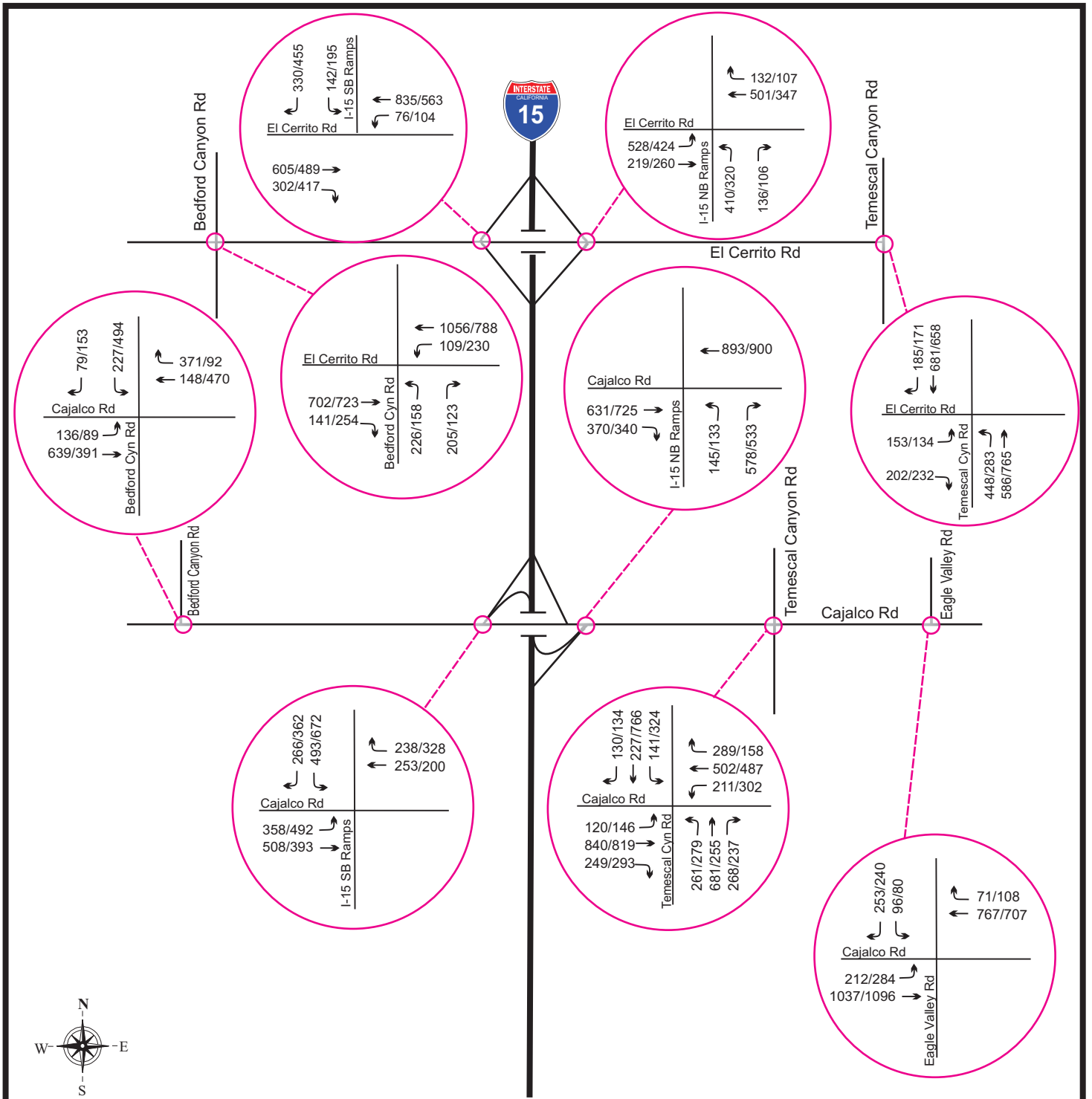

Opening Year (2020) AM/PM Peak Hour Traffic Intersections - No Build

Figure 6-8b

XXX/XXX AM/PM Peak Hour



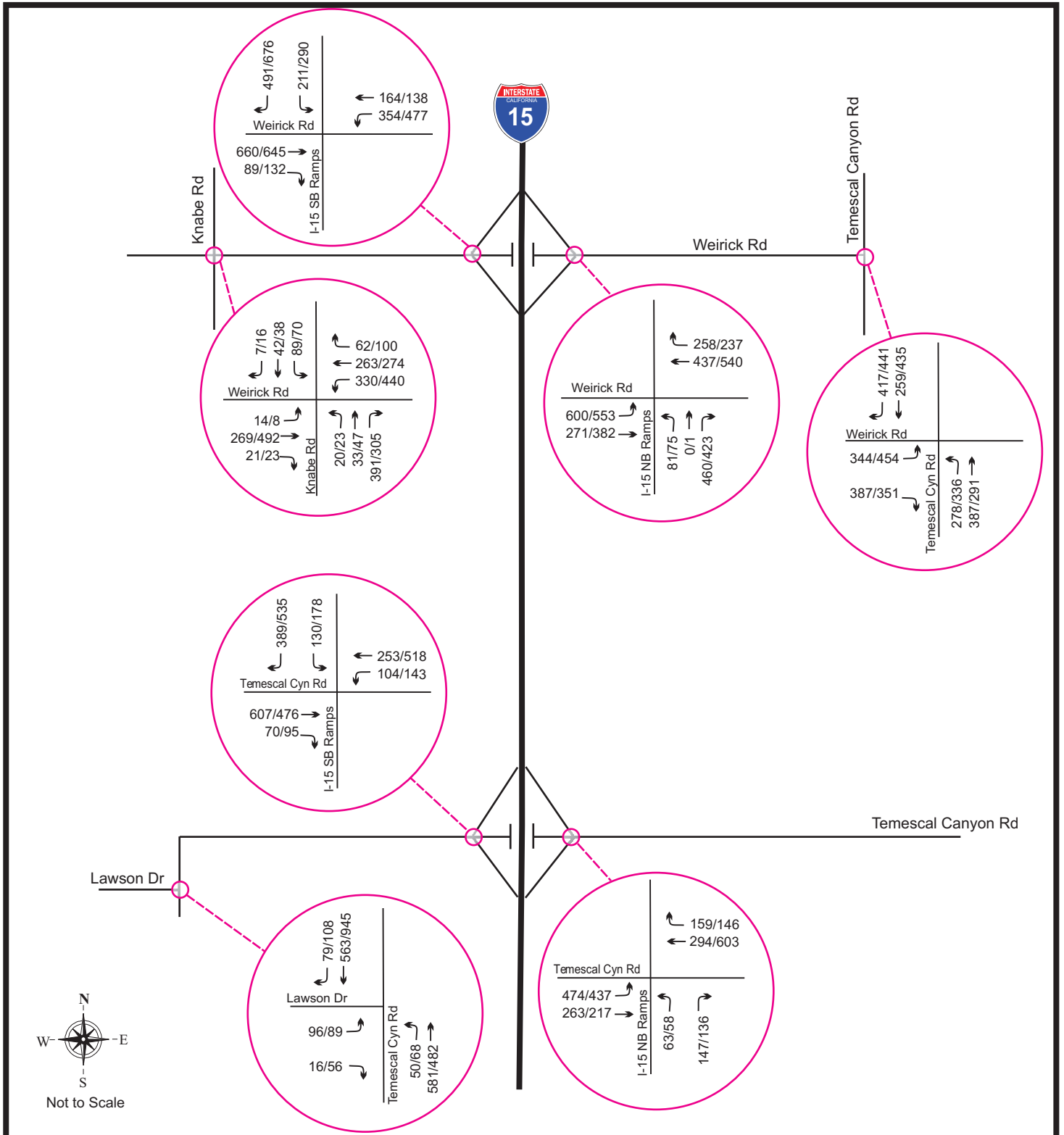

Opening Year (2020) AM/PM Peak Hour Traffic Intersections - No Build

Figure 6-8c

XXX/XXX AM/PM Peak Hour



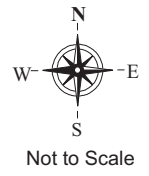
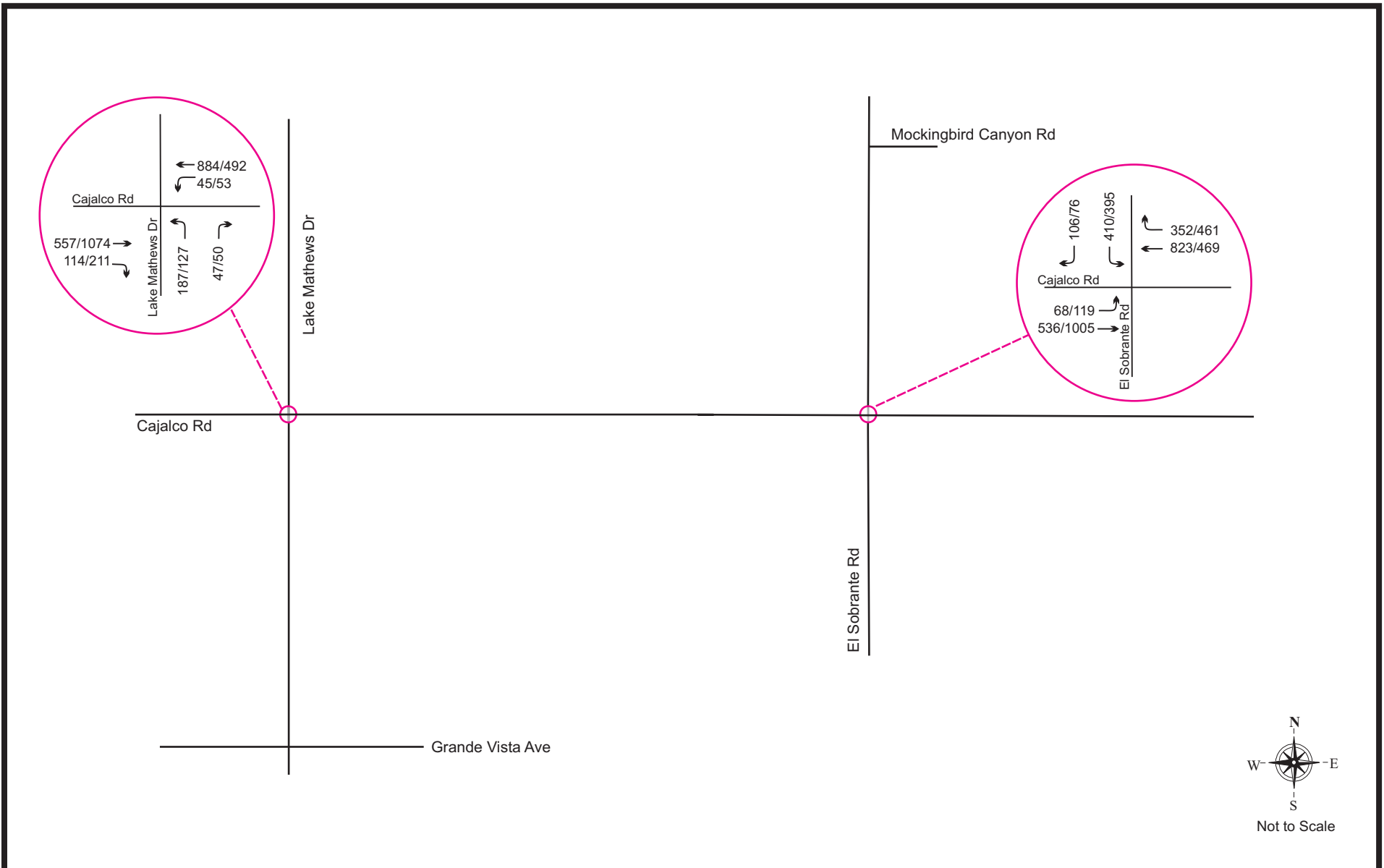

Opening Year (2020) AM/PM Peak Hour Traffic Intersections - No Build

Figure 6-8d

XXX/XXX AM/PM Peak Hour



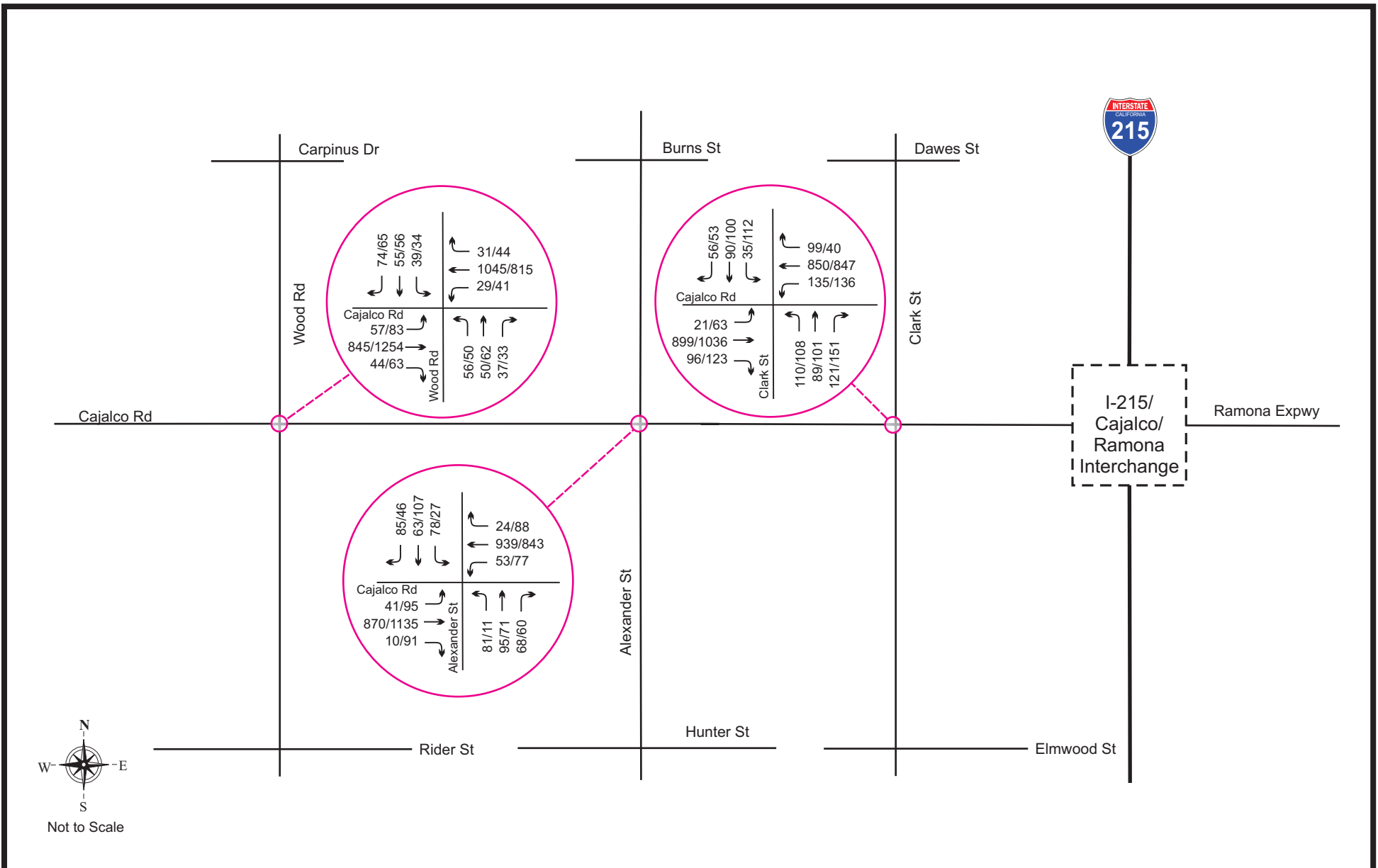

Opening Year (2020) AM/PM Peak Hour Traffic Intersections - No Build

Figure 6-8e

XXX/XXX AM/PM Peak Hour



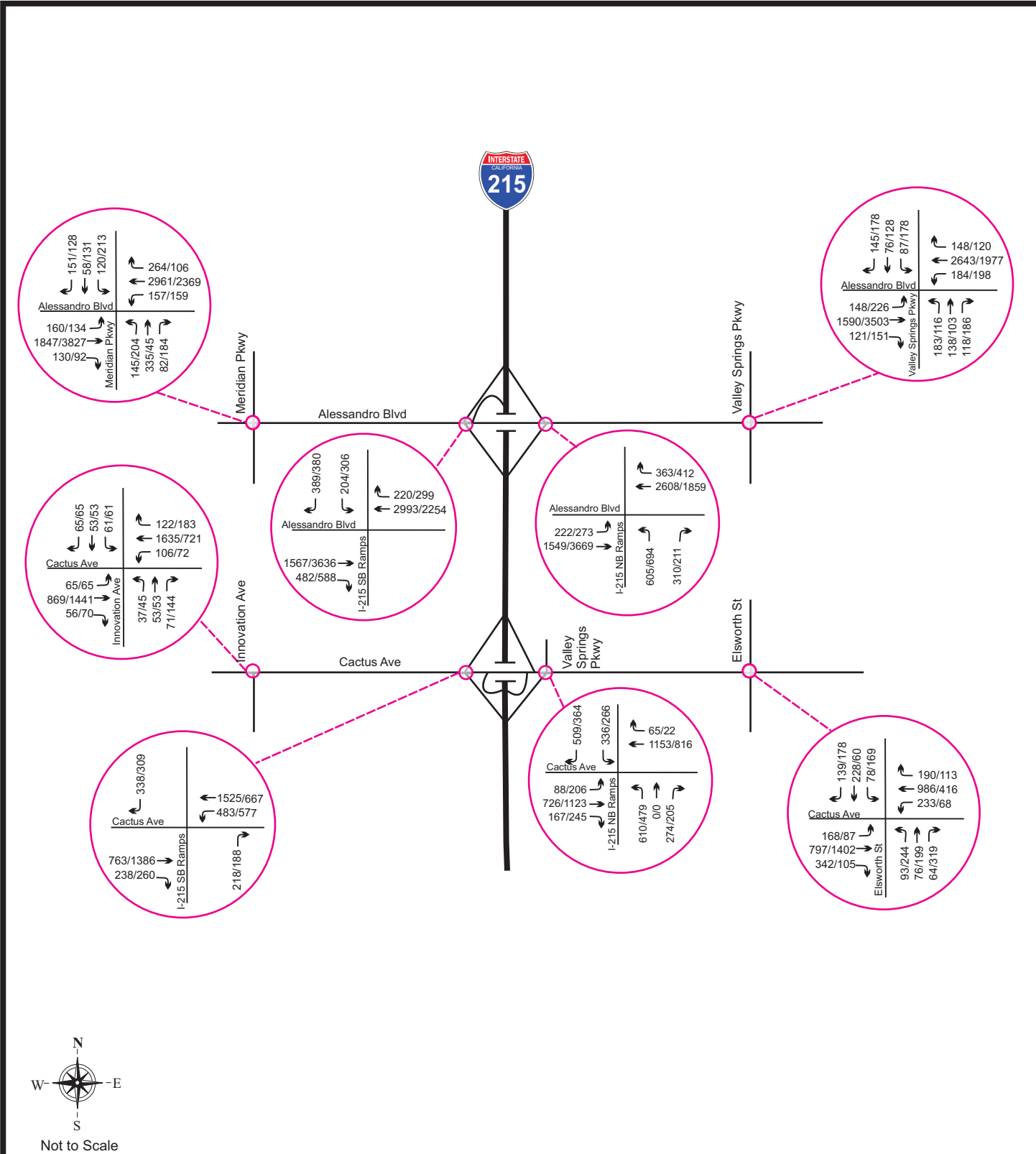

Opening Year (2020) AM/PM Peak Hour Traffic Intersections - No Build

Figure 6-8f

XXX/XXX AM/PM Peak Hour



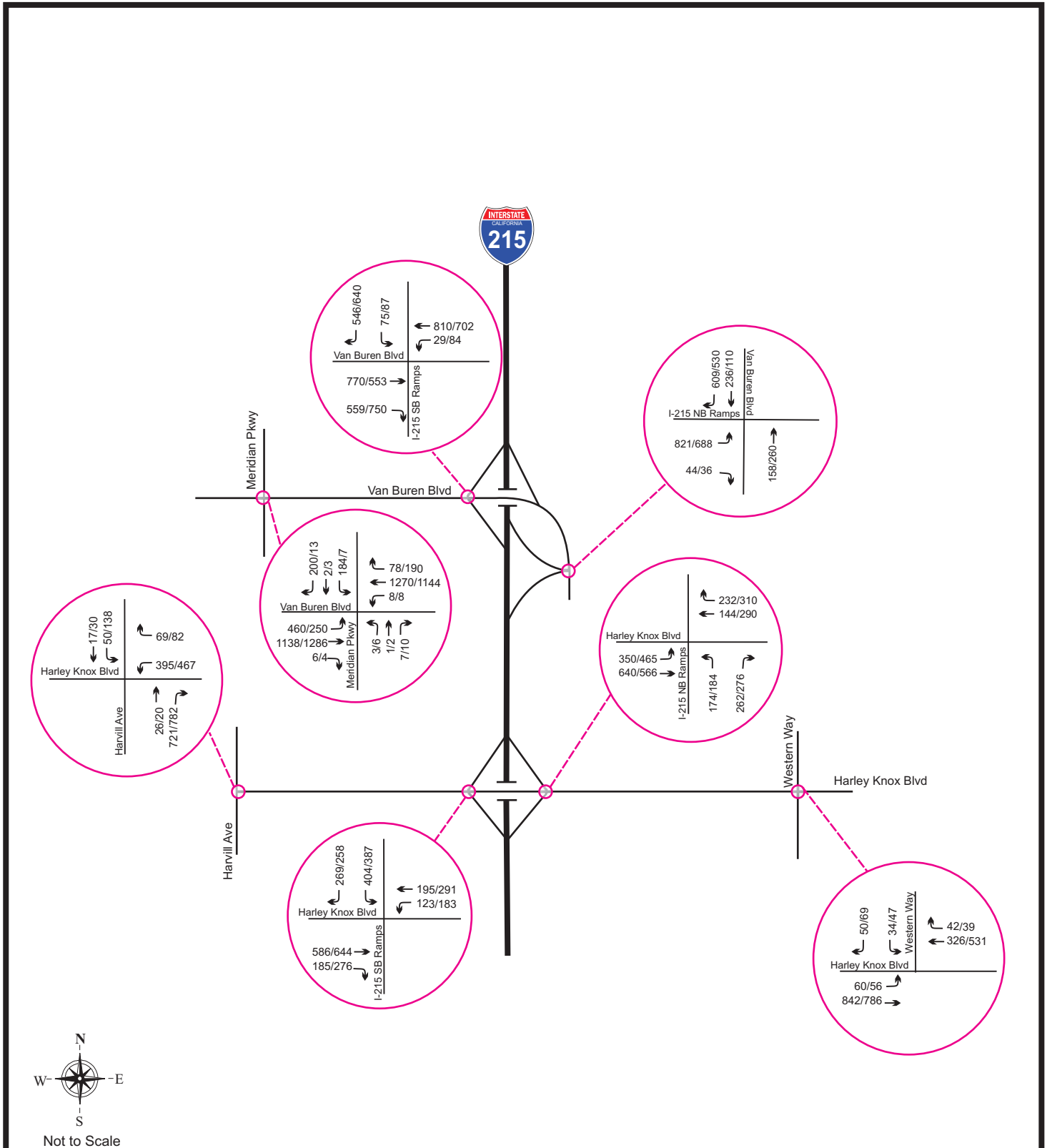

Opening Year (2020) AM/PM Peak Hour Traffic Intersections - No Build

Figure 6-8g

XXX/XXX AM/PM Peak Hour



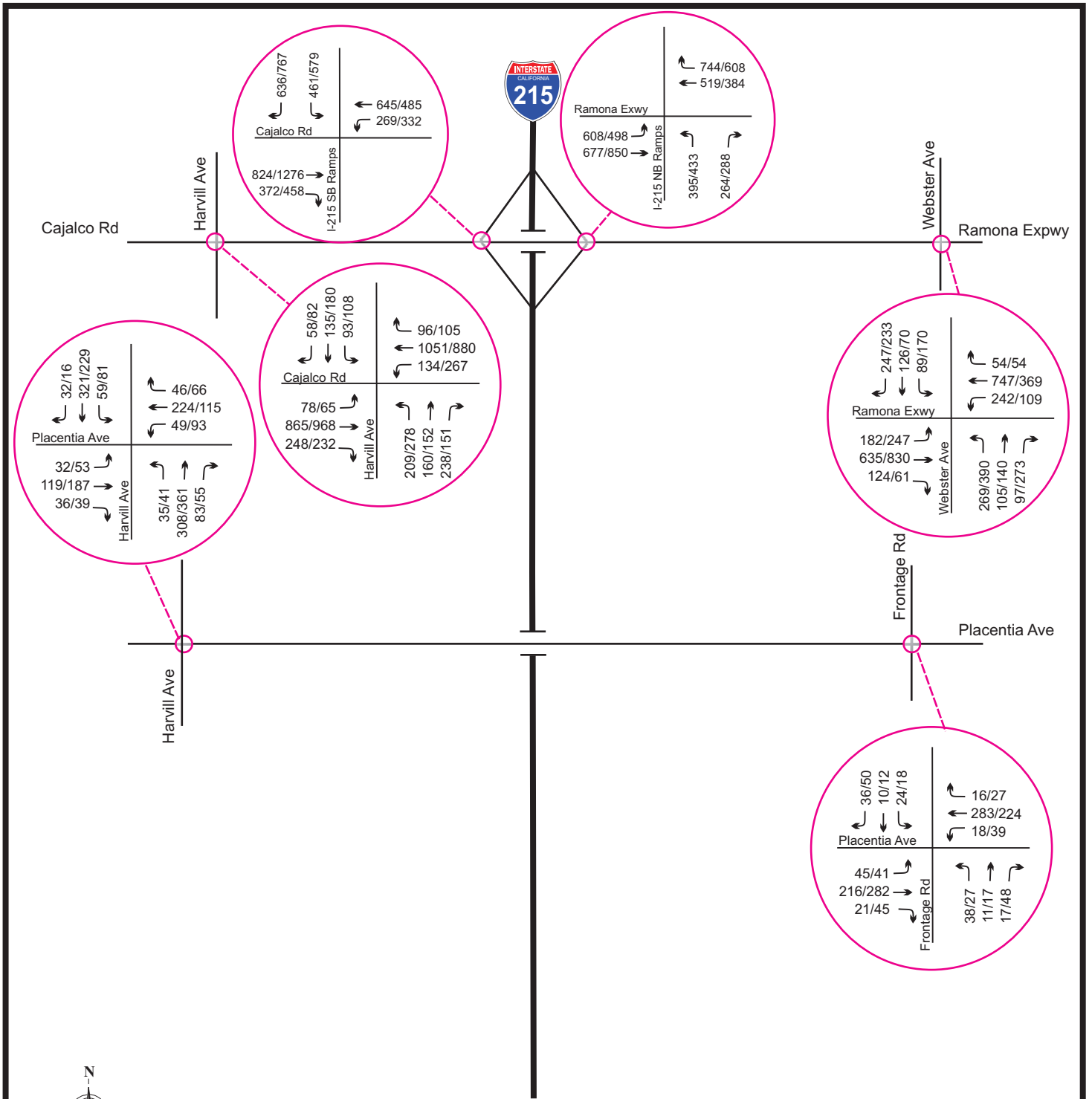

Opening Year (2020) AM/PM Peak Hour Traffic Intersections - No Build

Figure 6-8h

XXX/XXX AM/PM Peak Hour



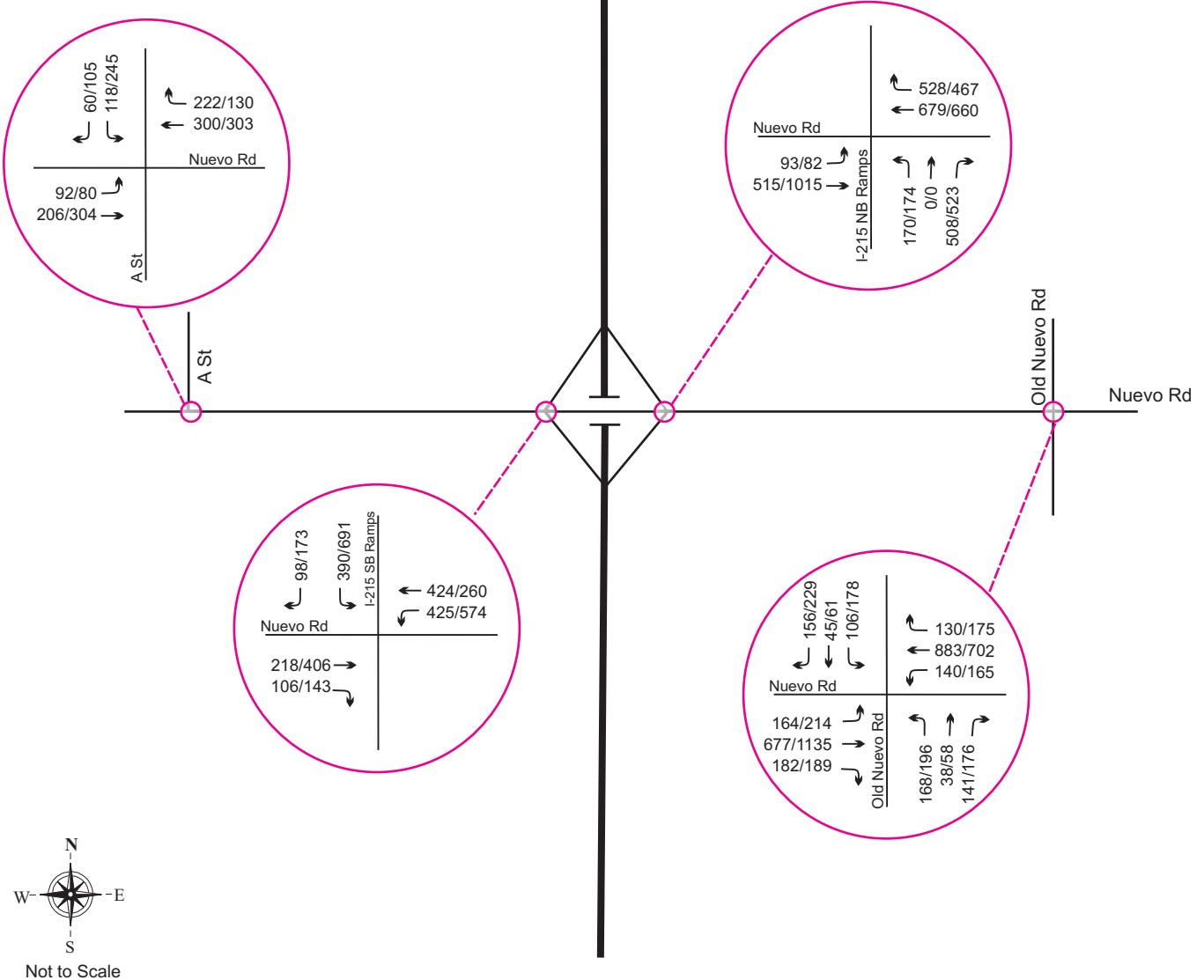

Opening Year (2020) AM/PM Peak Hour Traffic Intersections - No Build

Figure 6-8i

XXX/XXX AM/PM Peak Hour



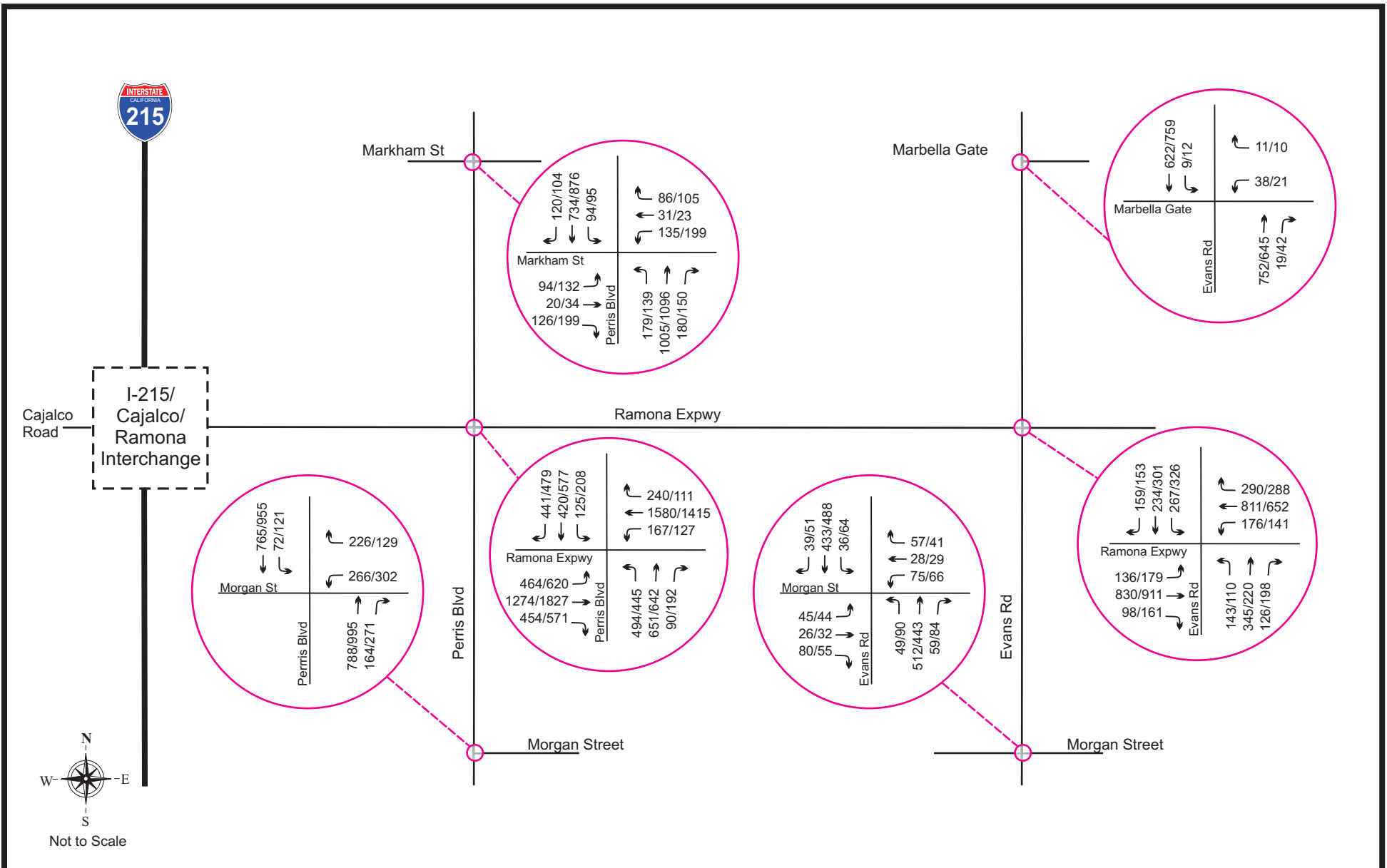

Opening Year (2020) AM/PM Peak Hour Traffic Intersections - No Build

Figure 6-8j

XXX/XXX AM/PM Peak Hour



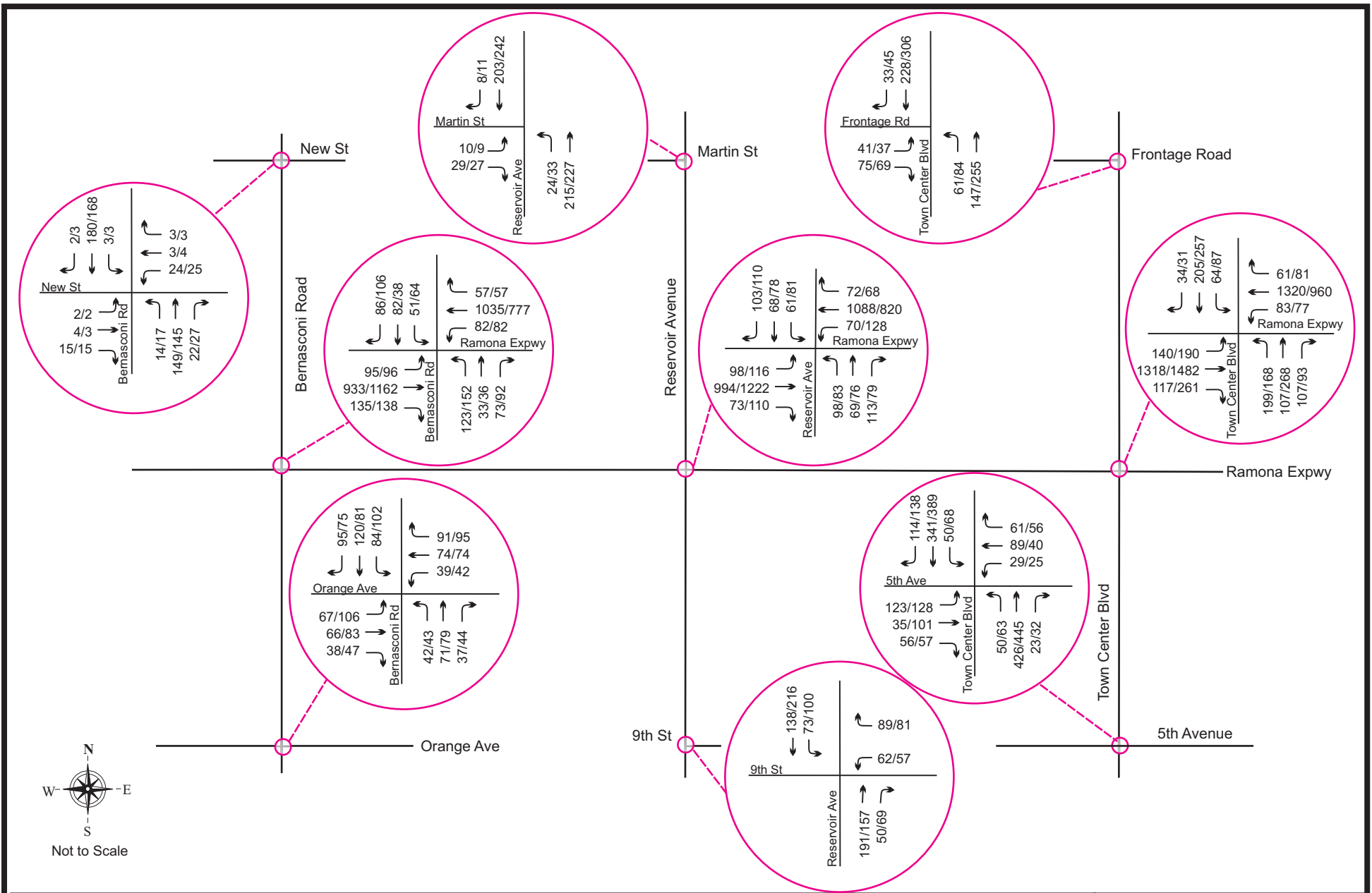

Opening Year (2020) AM/PM Peak Hour Traffic Intersections - No Build

Figure 6-8k

XXX/XXX AM/PM



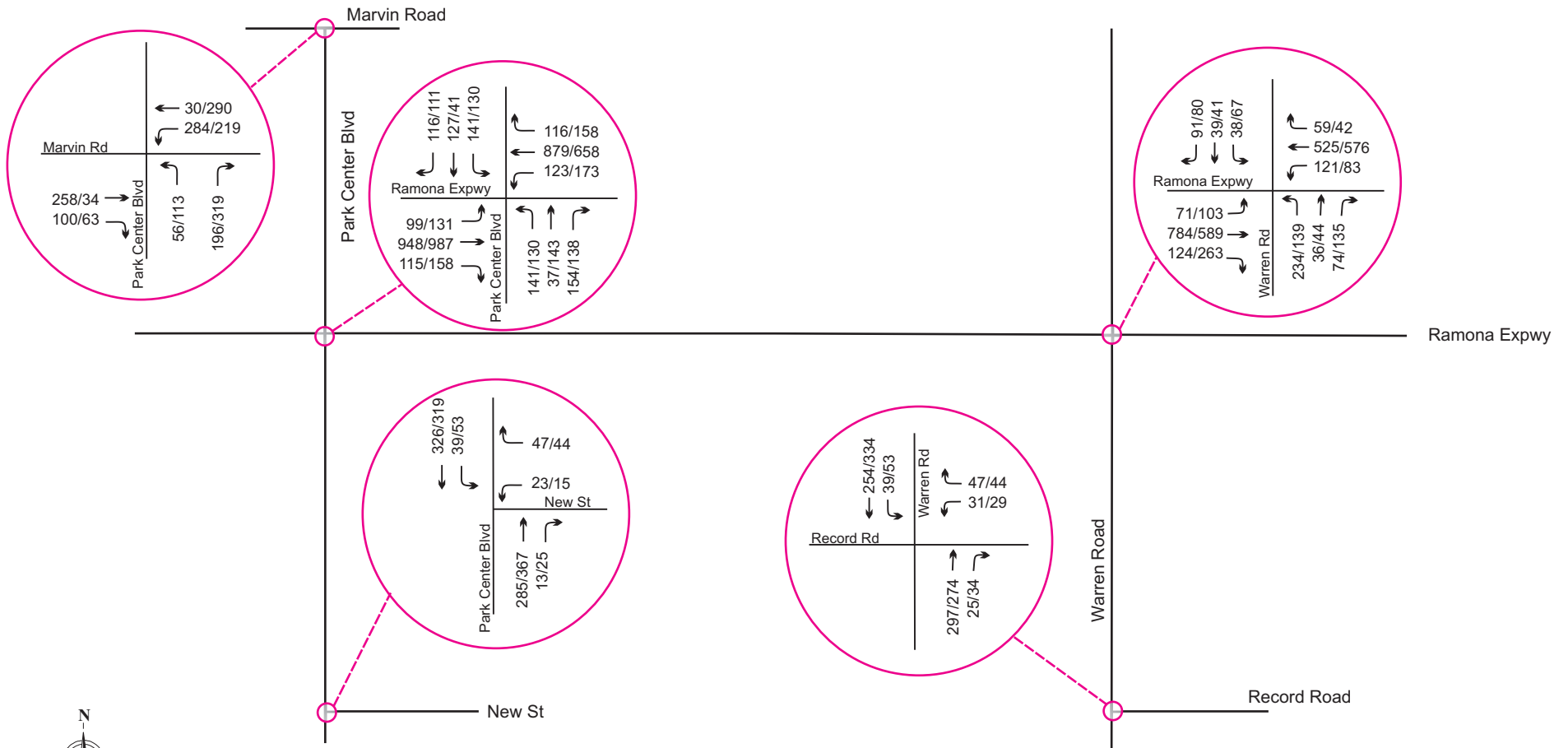

Opening Year (2020) AM/PM Peak Hour Traffic Intersections - No Build

Figure 6-8I

XXX/XXX AM/PM Peak Hour



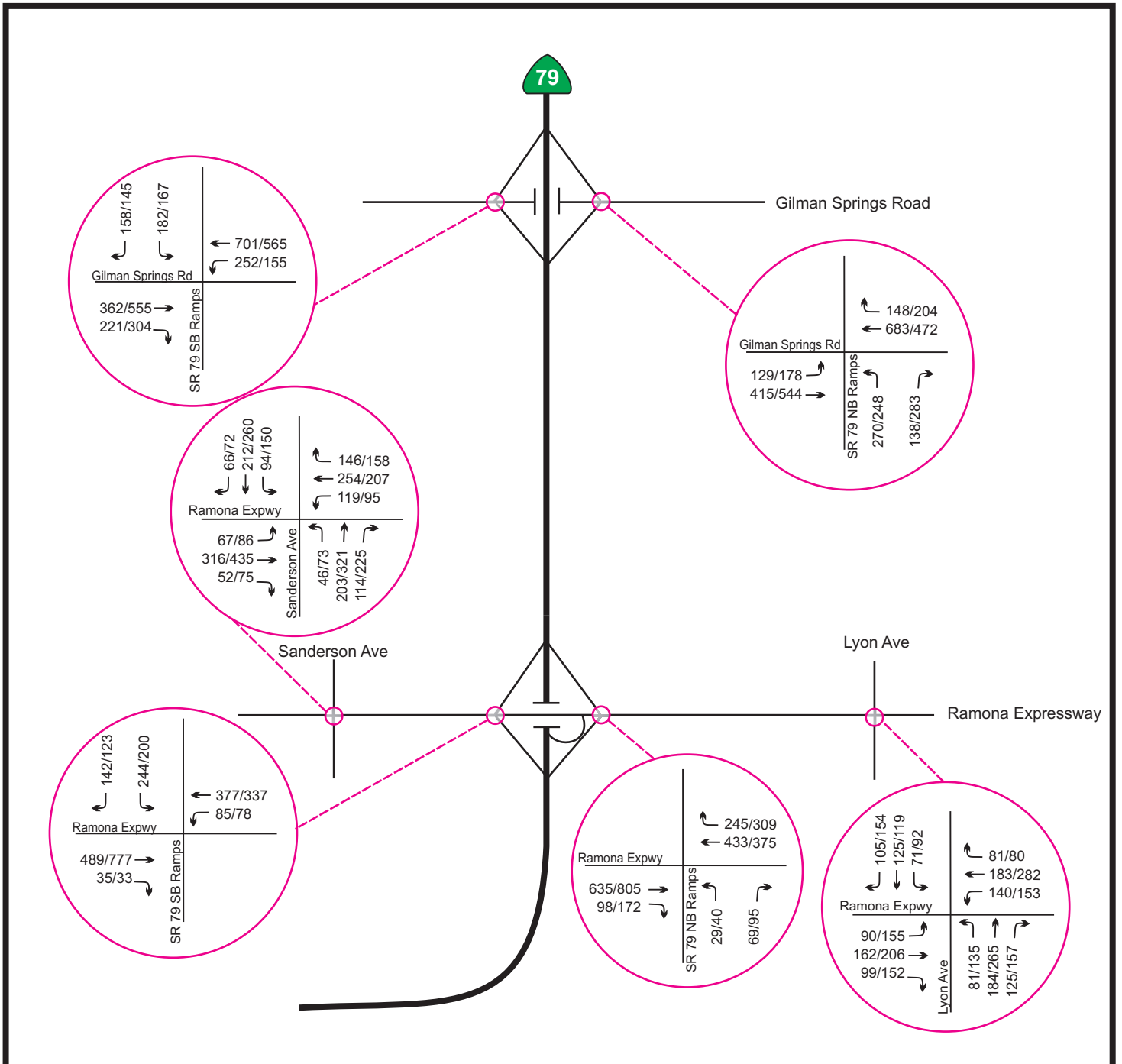

Not to Scale

Opening Year (2020) AM/PM Peak Hour Traffic Intersections - No Build

Figure 6-8m

XXX/XXX AM/PM Peak Hour



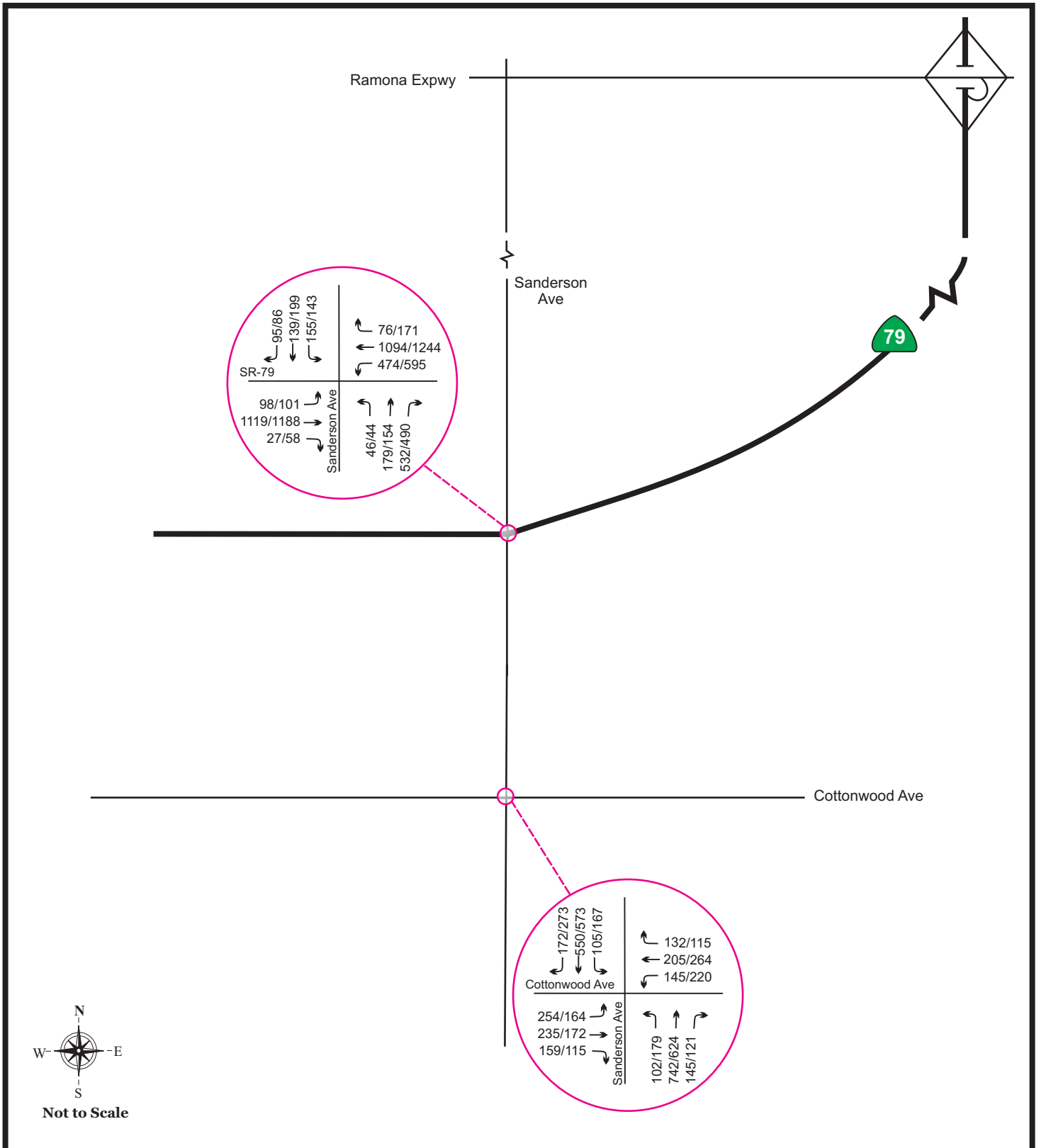

Opening Year (2020) AM/PM Peak Hour Traffic Intersections - No Build

Figure 6-8n

XXX/XXX AM/PM Peak Hour



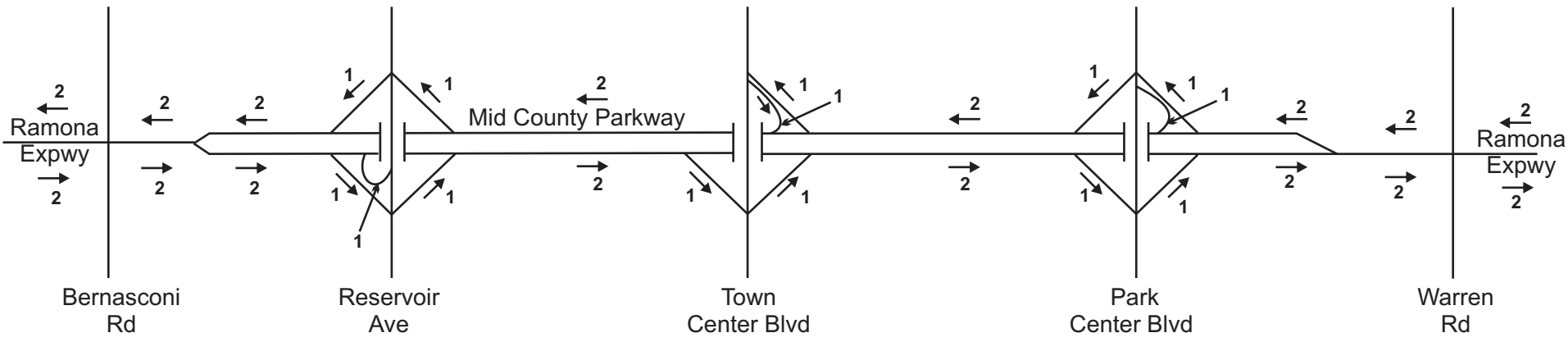

**Opening Year (2020) Freeway Mainline Lane Geometry
Mid County Parkway - Build**

Figure 6-9

Legend

←^x Number of Lanes



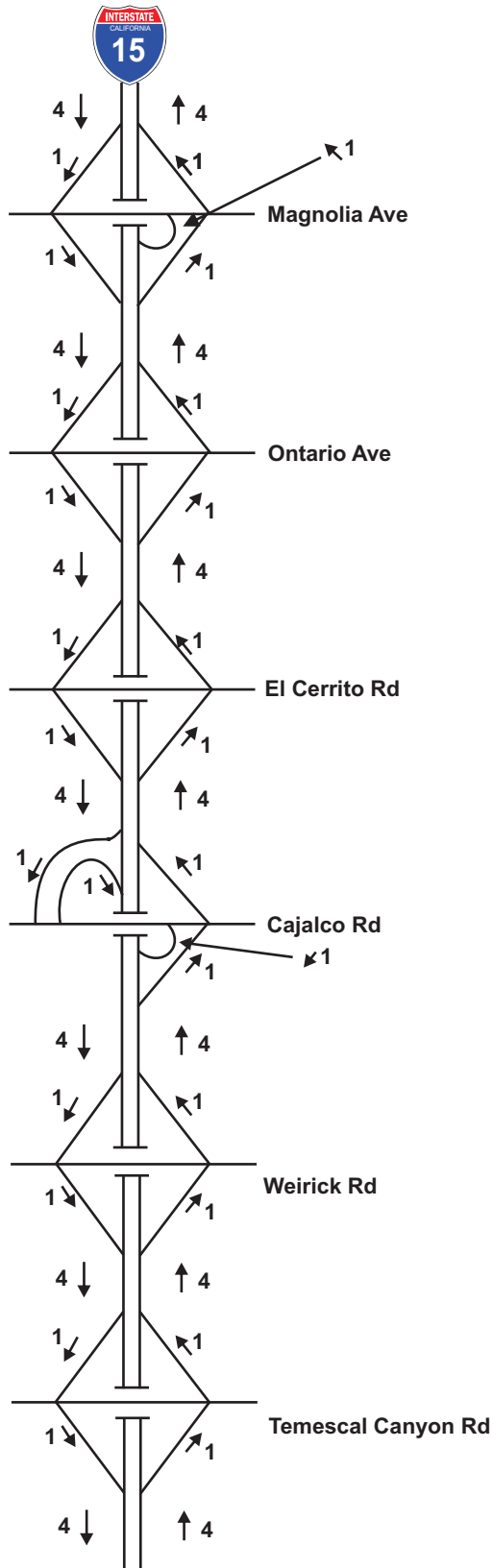

Note:
Two Express Lanes in each direction of travel will be provided in addition to the lanes indicated on I-15.

Opening Year (2020) Freeway Mainline Lane Geometry Interstate 15 - Build

Figure 6-10

Legend

- Direction of Travel
- X : Number of Lanes (Mixed Flow)



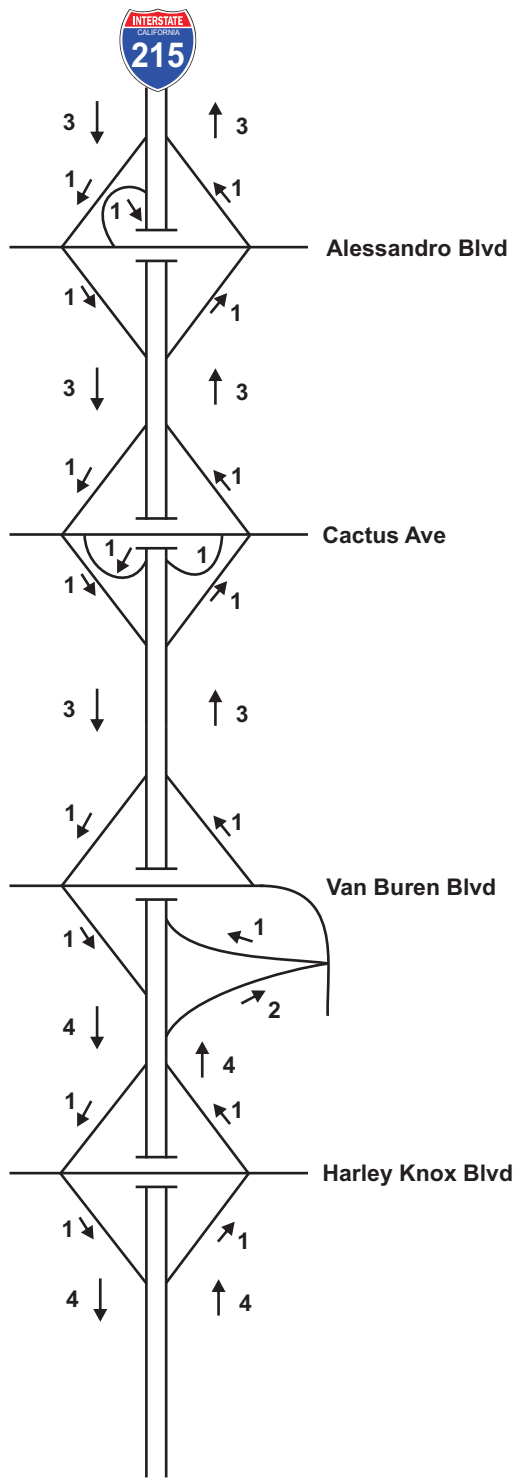

Not to Scale

**Opening Year (2020)
Freeway Mainline Lane Geometry
Interstate 215 - Build**

Figure 6-11a

Legend

→ Direction of Travel

X : Number of Lanes (Mixed Flow)



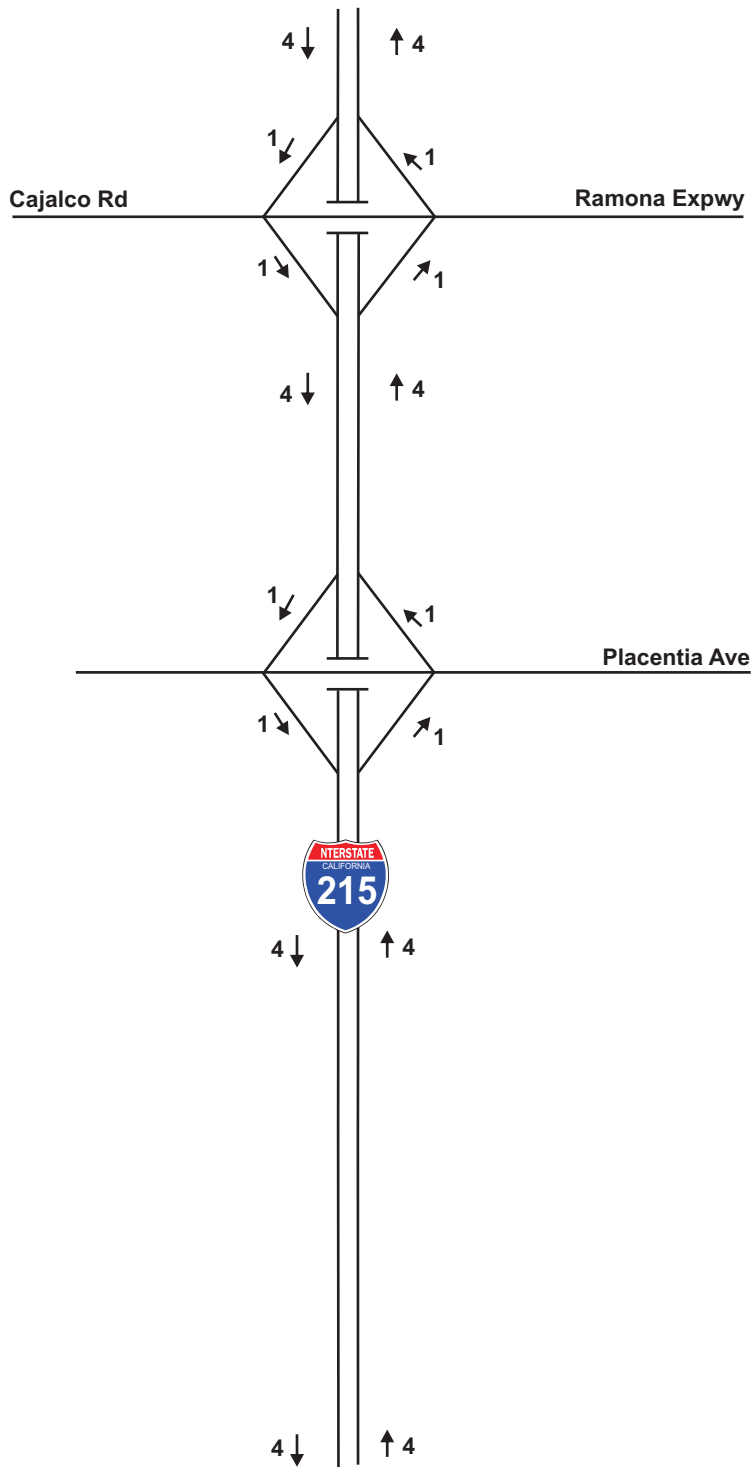

**Opening Year (2020)
Freeway Mainline Lane Geometry
Interstate 215 - Build**

Figure 6-11b

- Legend**
- Direction of Travel
 - X : Number of Lanes (Mixed Flow)



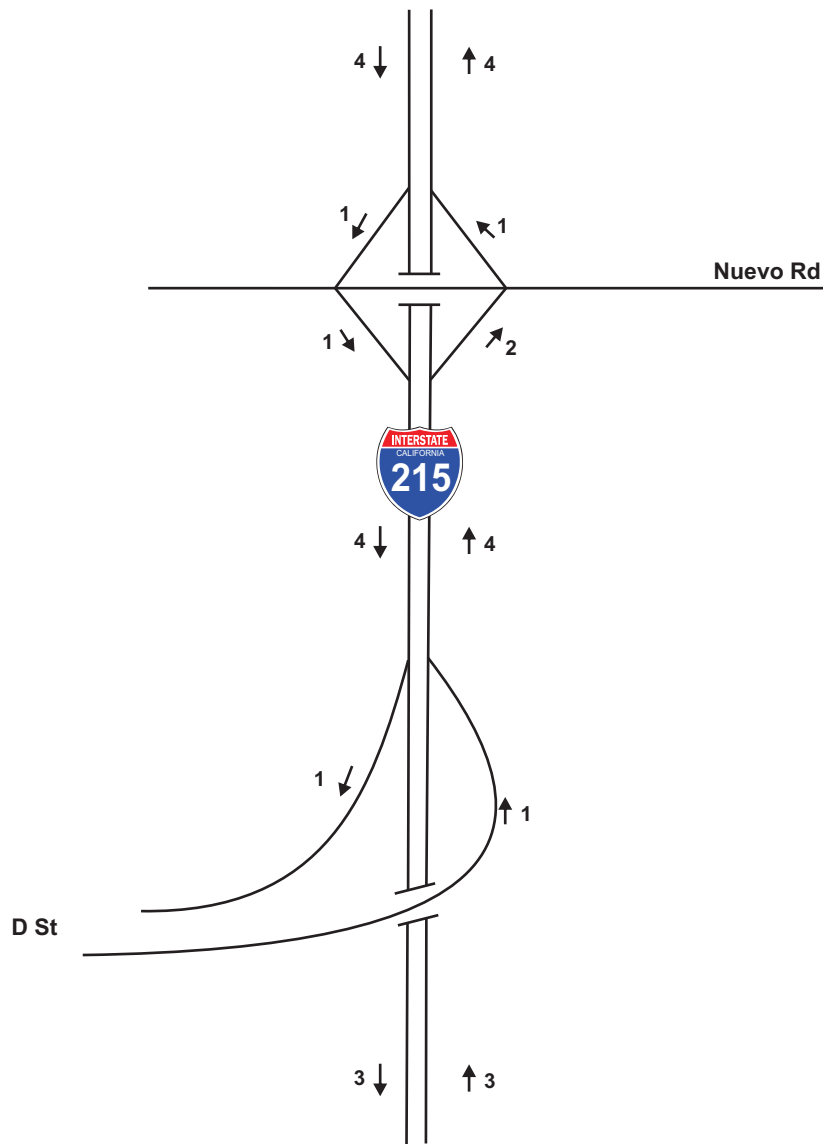

**Opening Year (2020)
Freeway Mainline Lane Geometry
Interstate 215 - Build**

Figure 6-11c

- Legend**
- Direction of Travel
 - X : Number of Lanes (Mixed Flow)



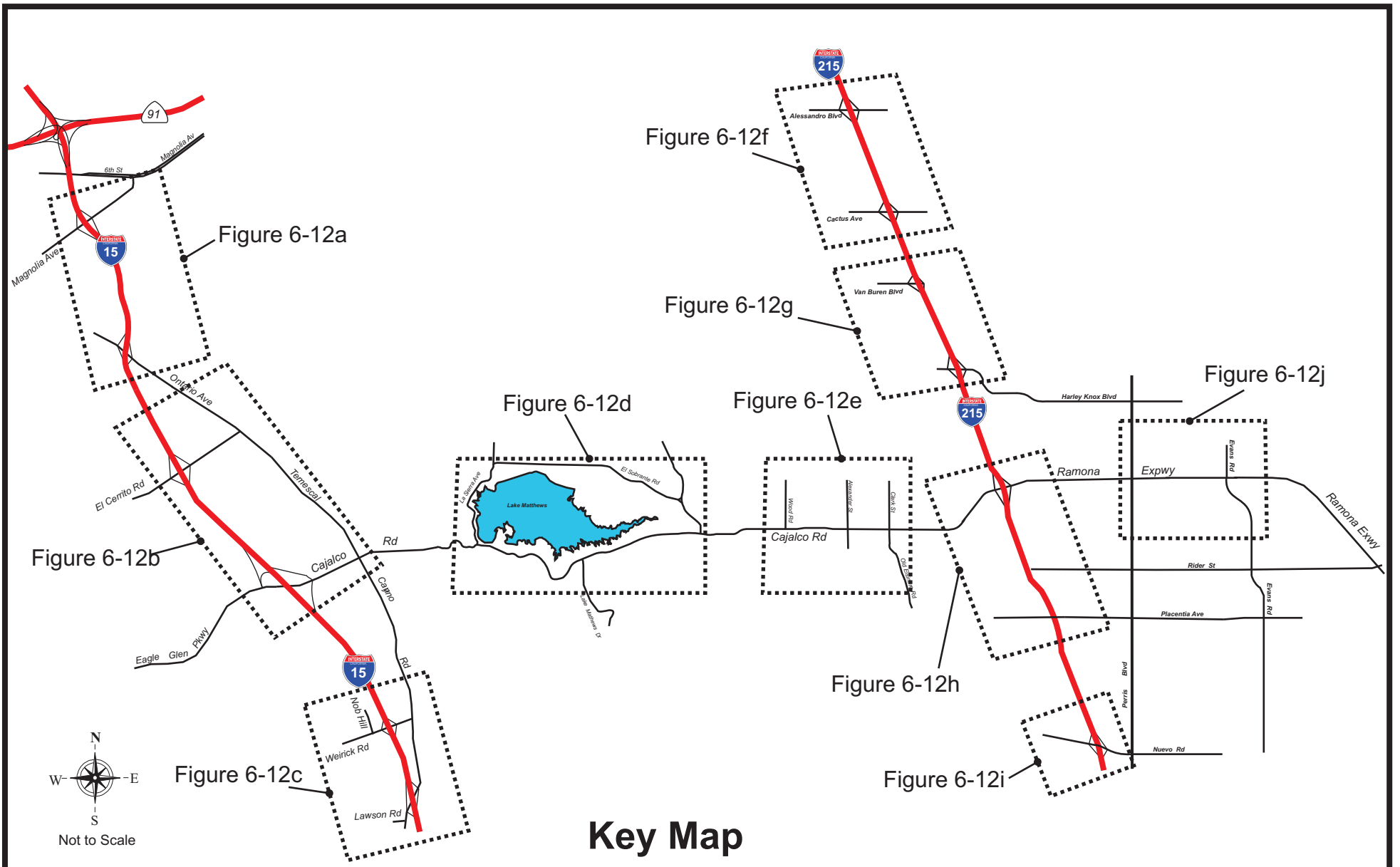

Horizon Year (2020) Intersection Lane Geometry Build

Figure 6-12

Legend:

 **Figure Areas**



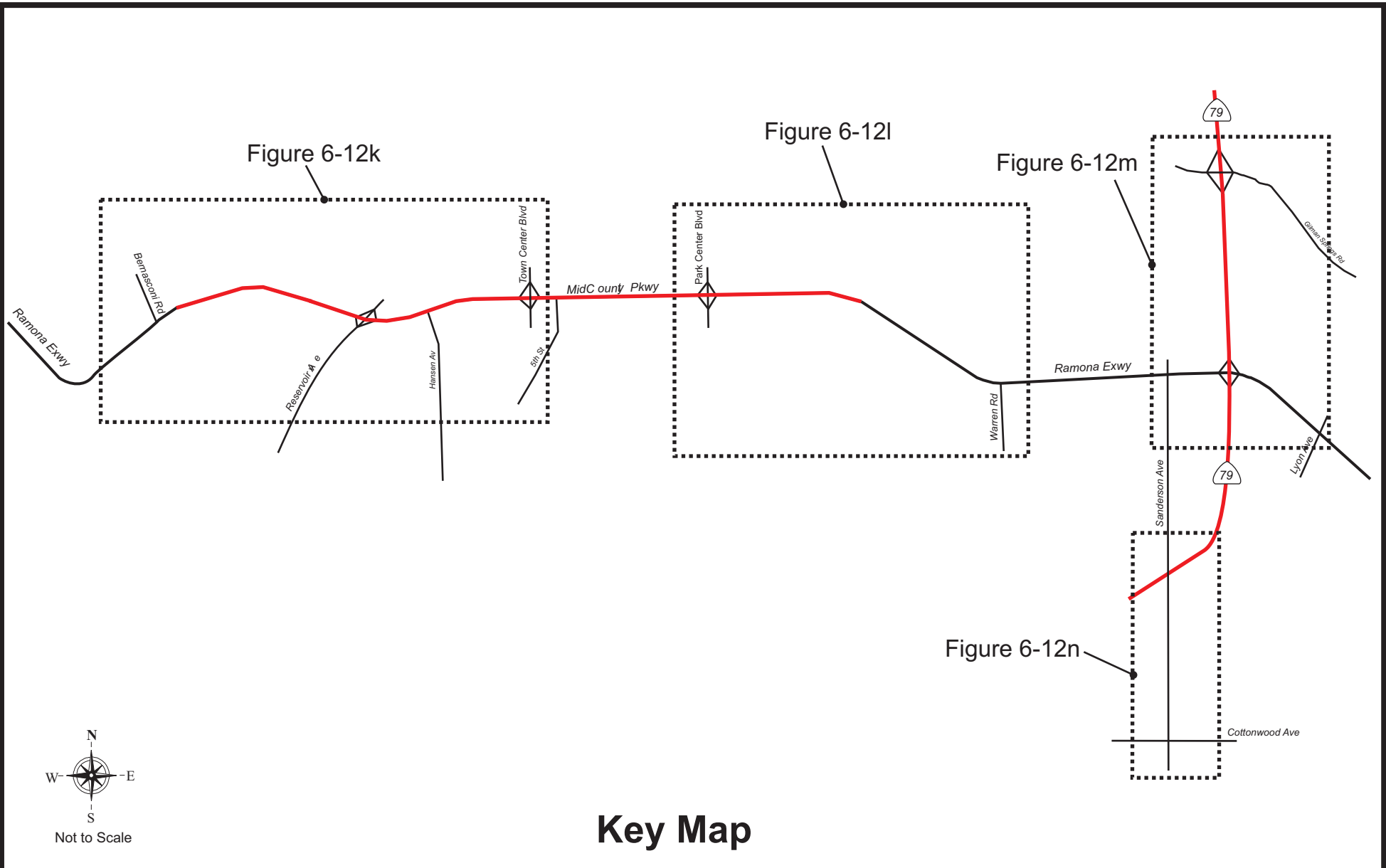

Key Map

Horizon Year (2020) Intersection Lane Geometry Build

Figure 6-12 (cont.)

Legend:

 Figure Areas



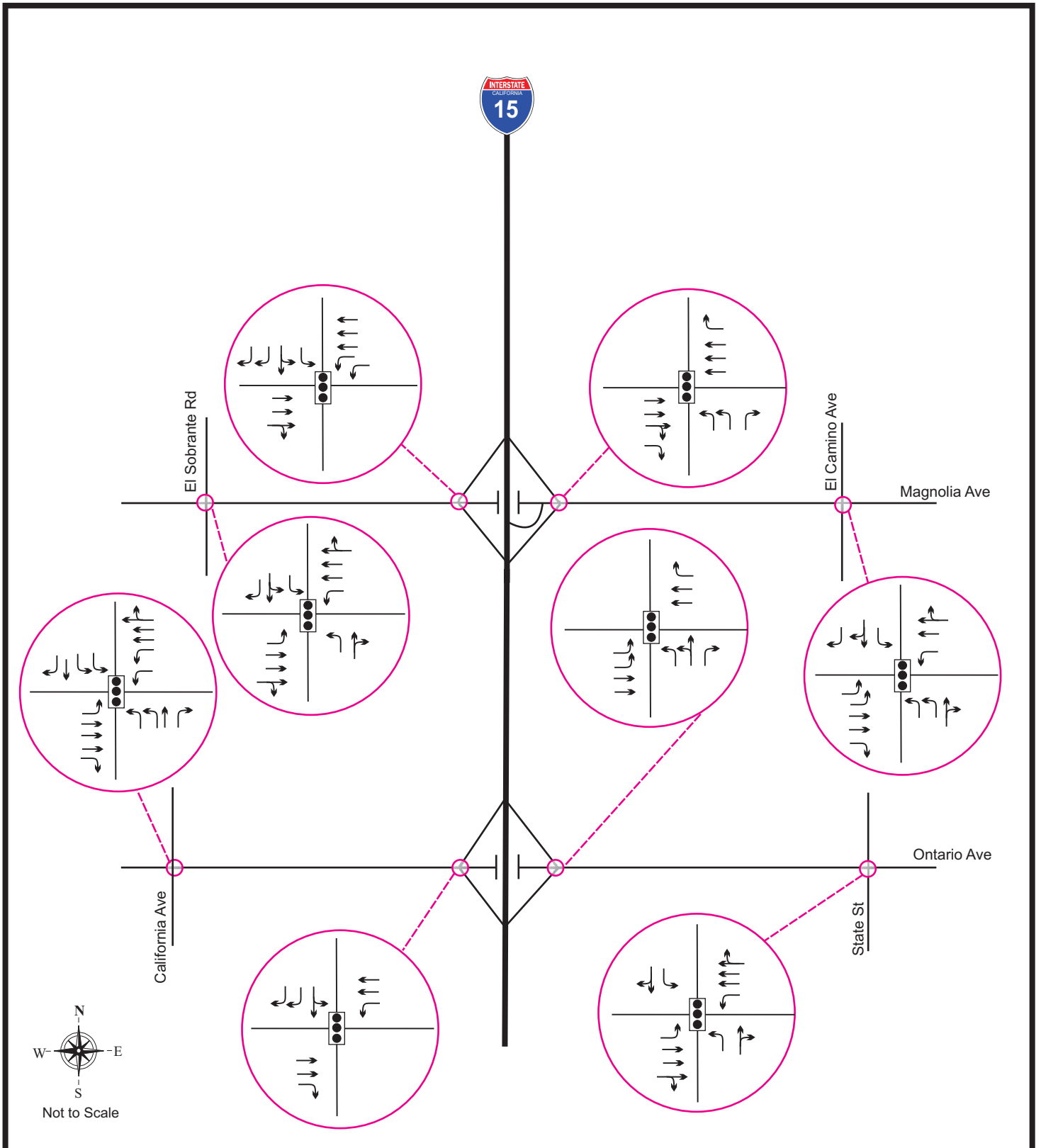

**Opening Year (2020) Intersection
Lane Geometry - Build**

Figure 6-12a

Legend:



Signal



Traffic Lane



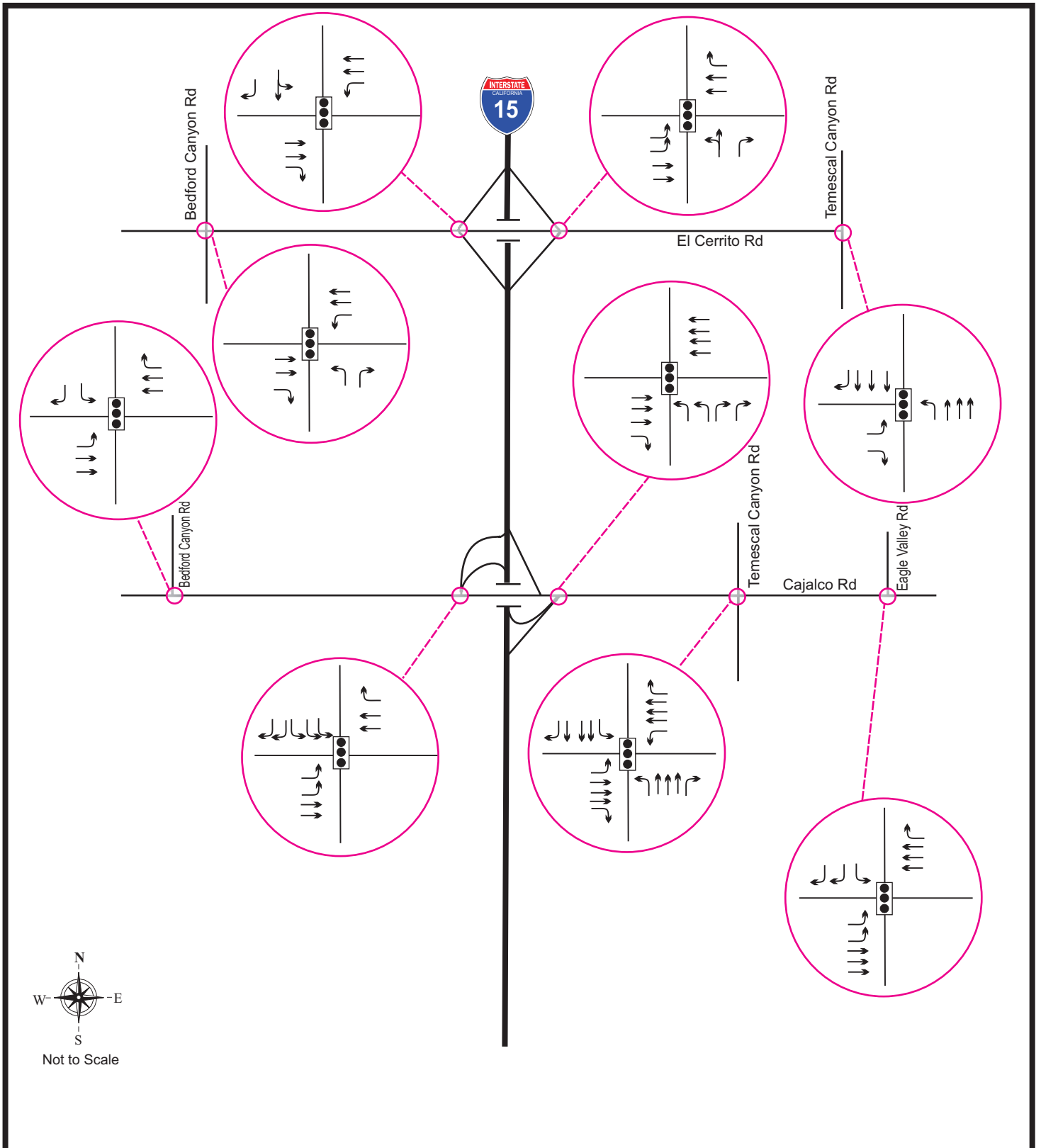

**Opening Year (2020) Intersection
Lane Geometry - Build**

Figure 6-12b

Legend:



Signal



Traffic Lane



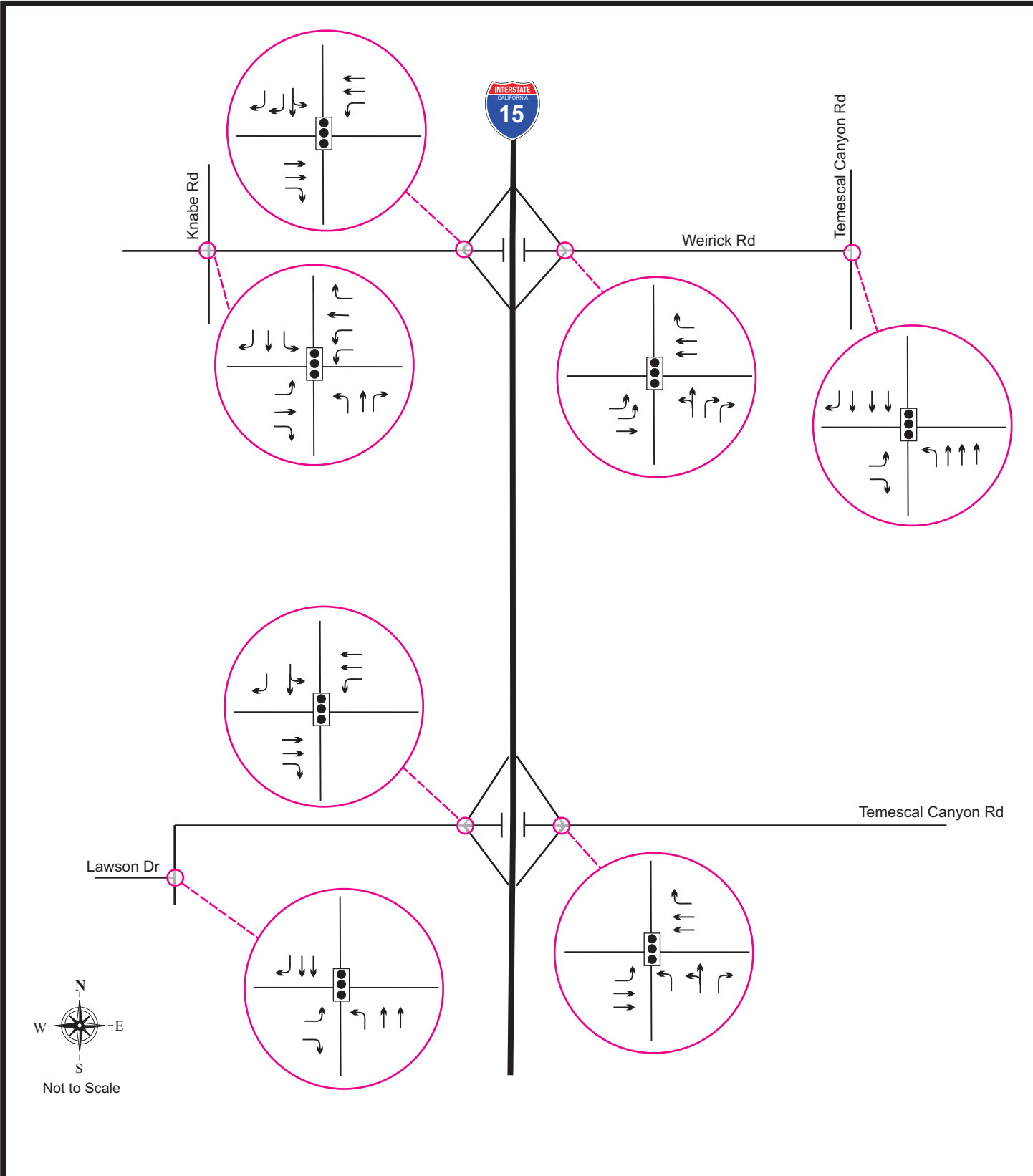

**Opening Year (2020) Intersection
Lane Geometry - Build**

Figure 6-12c

Legend:

-  Signal
-  Traffic Lane



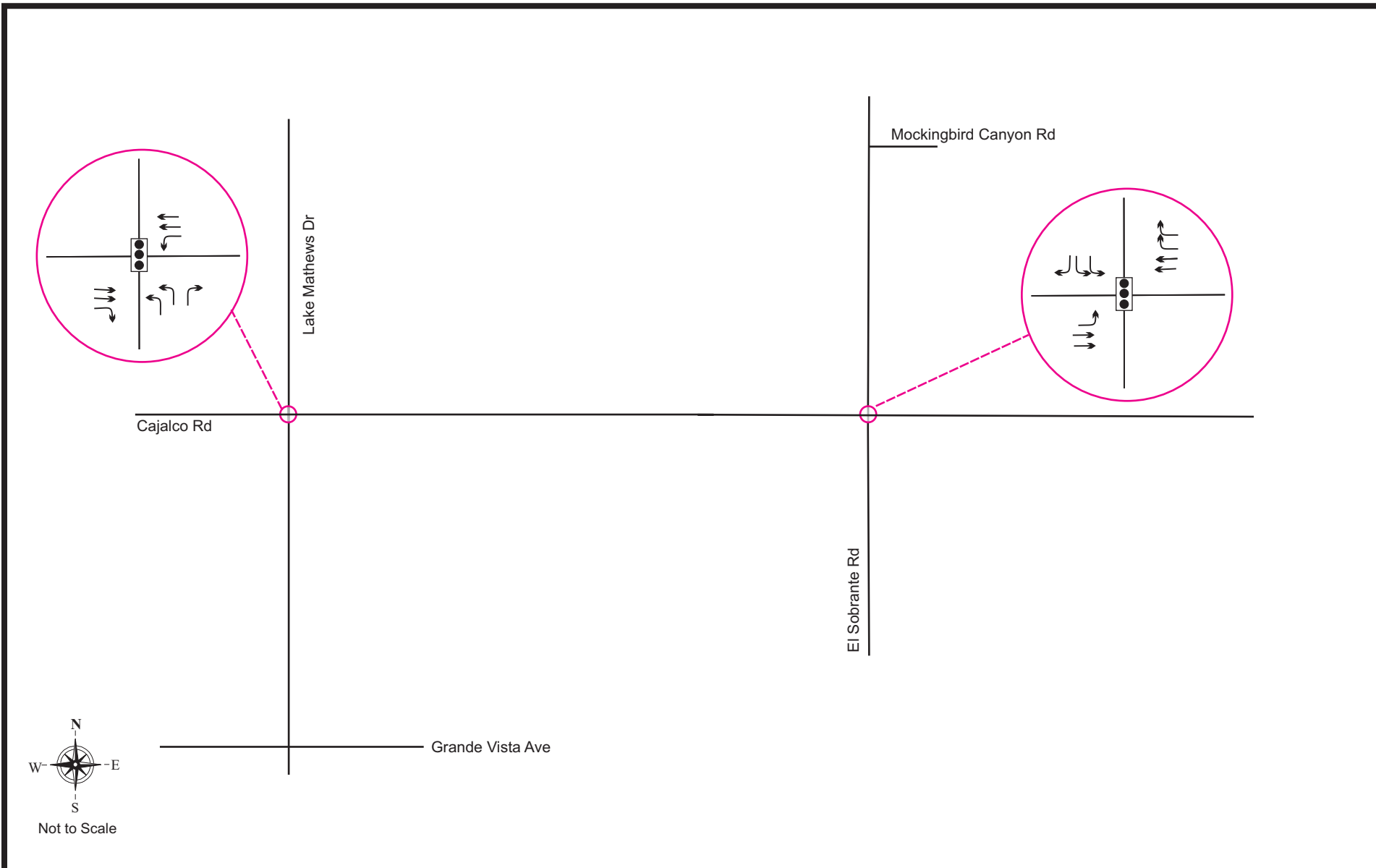

**Opening Year (2020) Intersection
Lane Geometry - Build**

Figure 6-12d

Legend:

-  Signal
-  Traffic Lane



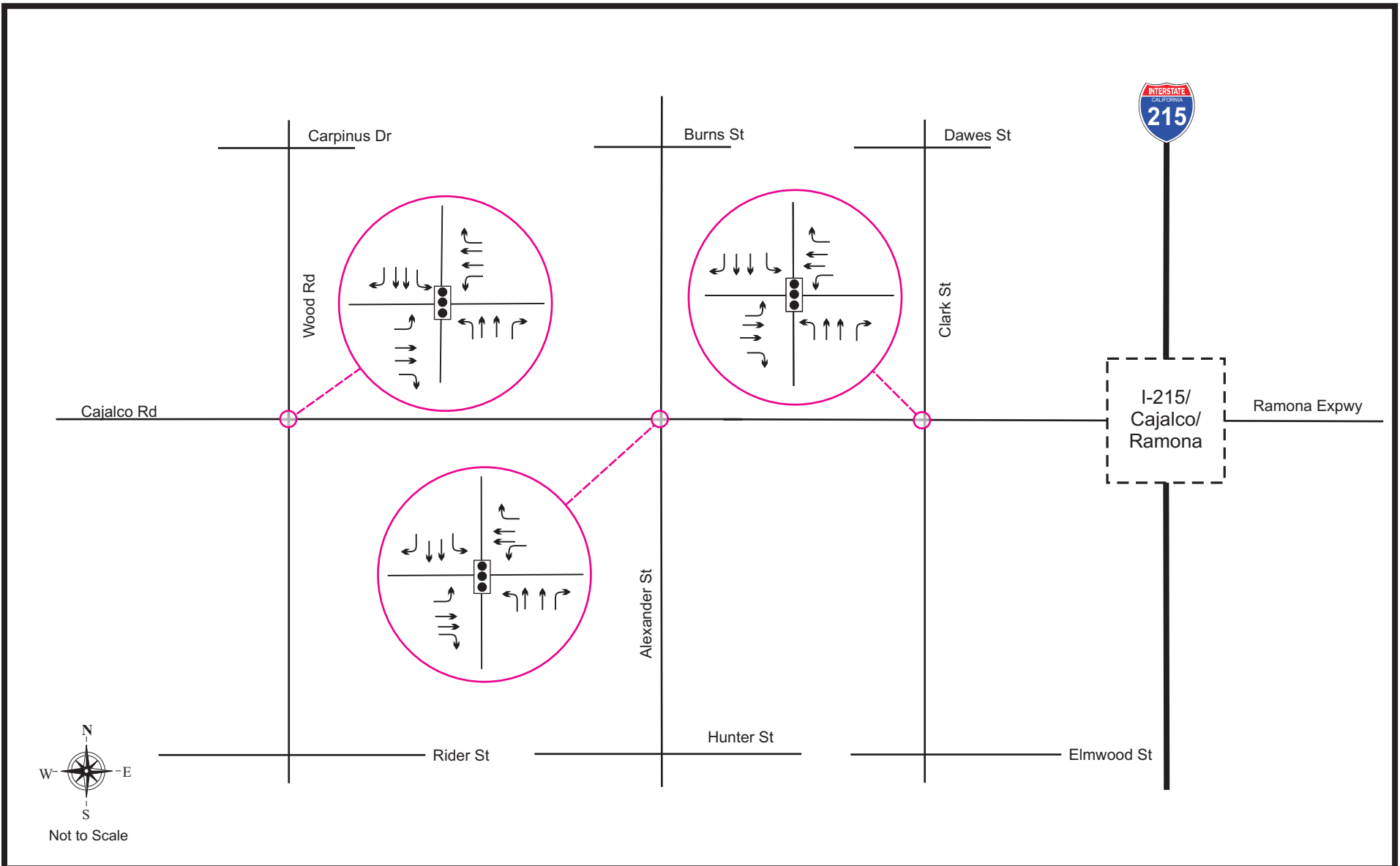

**Opening Year (2020) Intersection
Lane Geometry - Build**

Figure 6-12e

Legend:

-  Signal
-  Traffic Lane



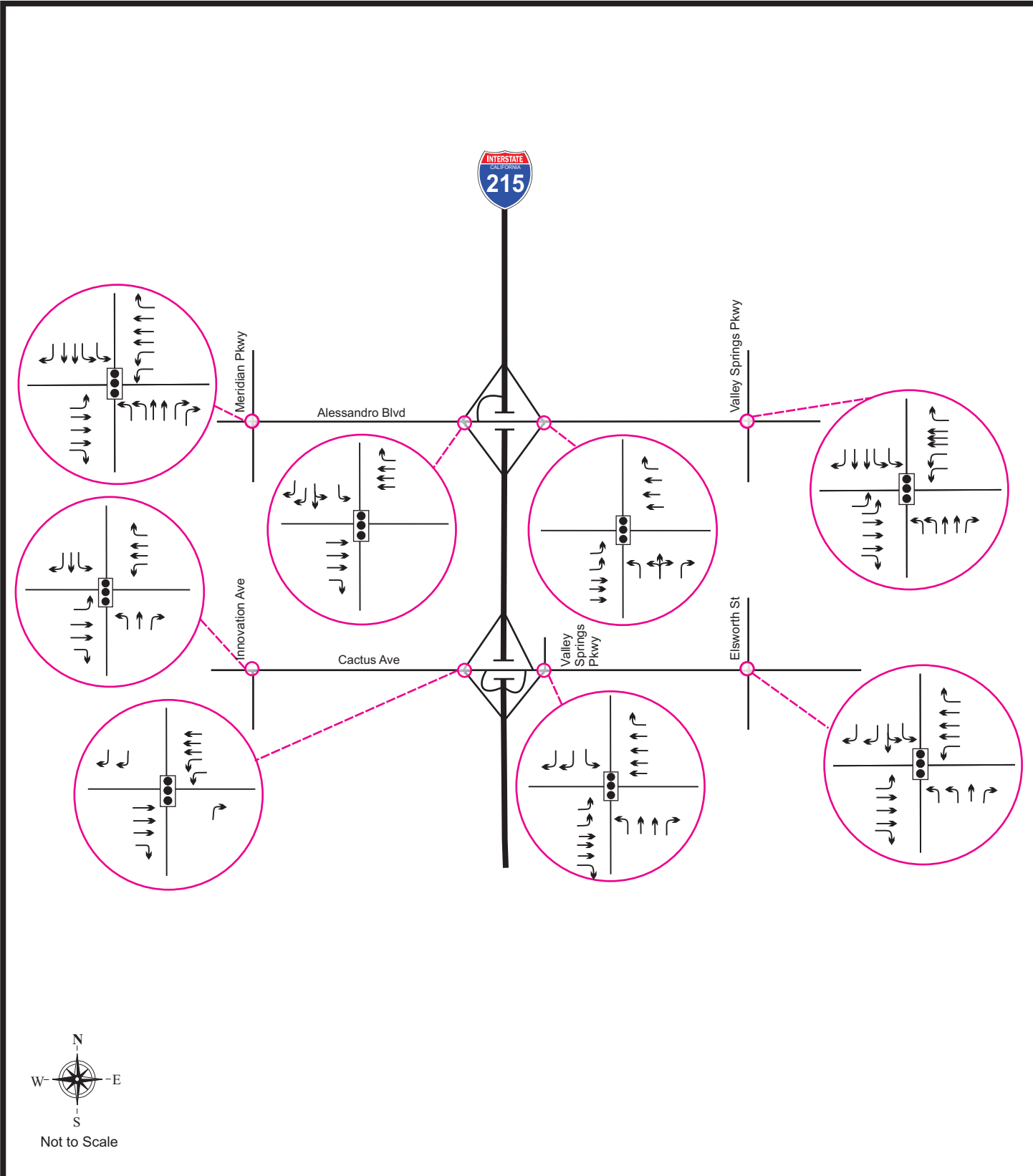

Opening Year (2020) Intersection Lane Geometry - Build

Figure 6-12f

Legend:



Signal



Traffic Lane



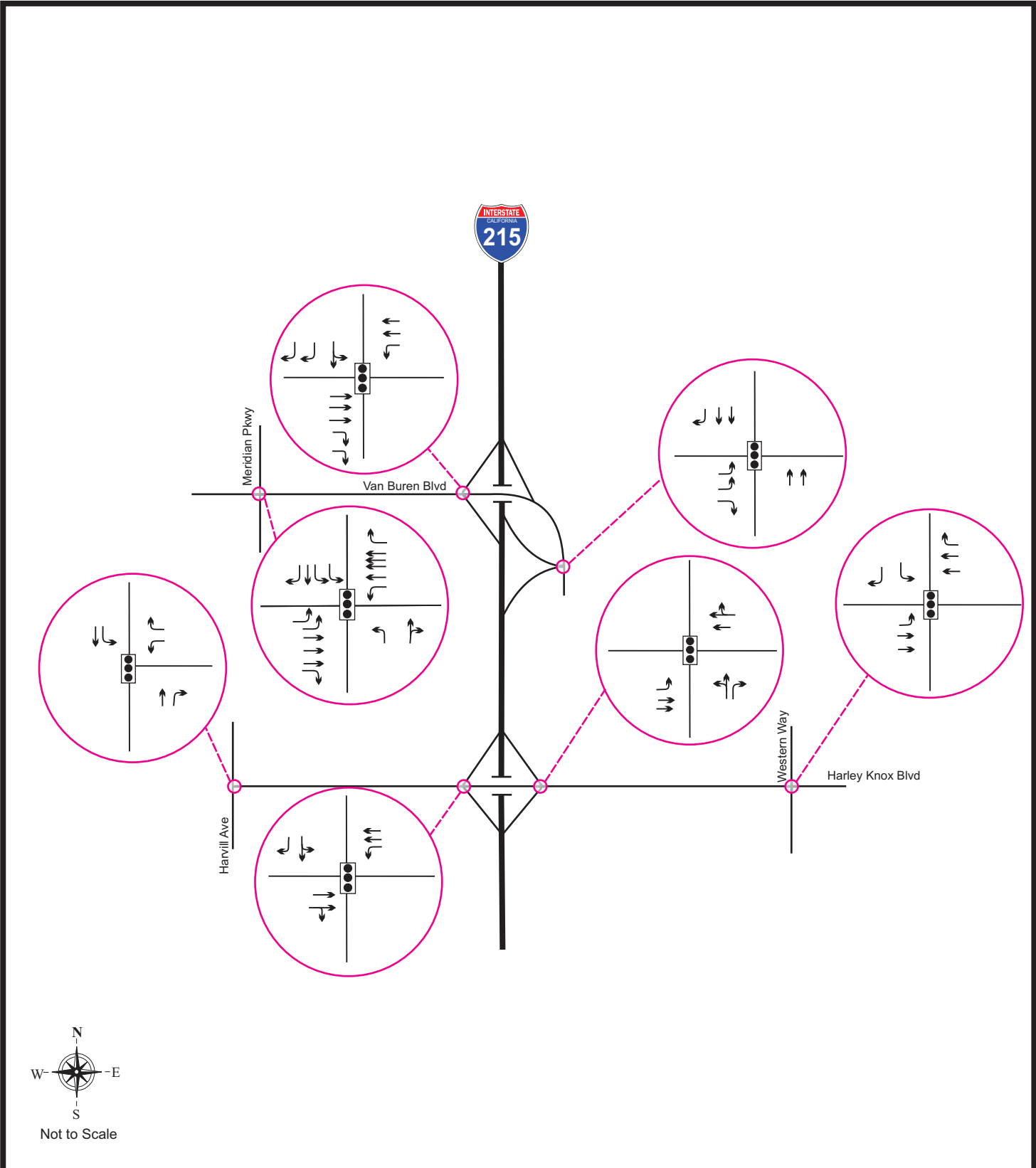

**Opening Year (2020) Intersection
Lane Geometry - Build**

Figure 6-12g

Legend:

-  Signal
-  Traffic Lane



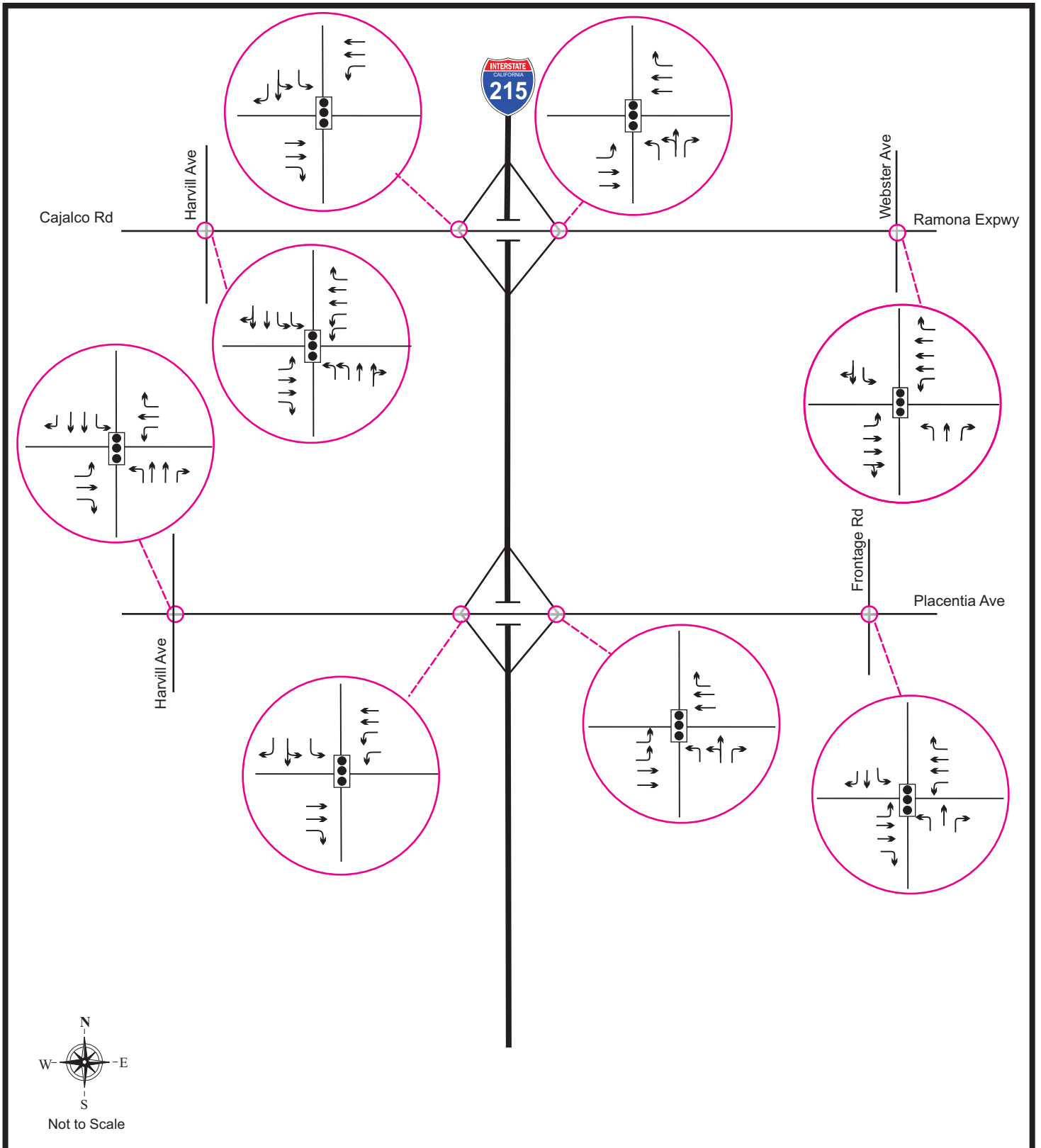

**Opening Year (2020) Intersection
Lane Geometry - Build**

Figure 6-12h

Legend:



Signal



Traffic Lane



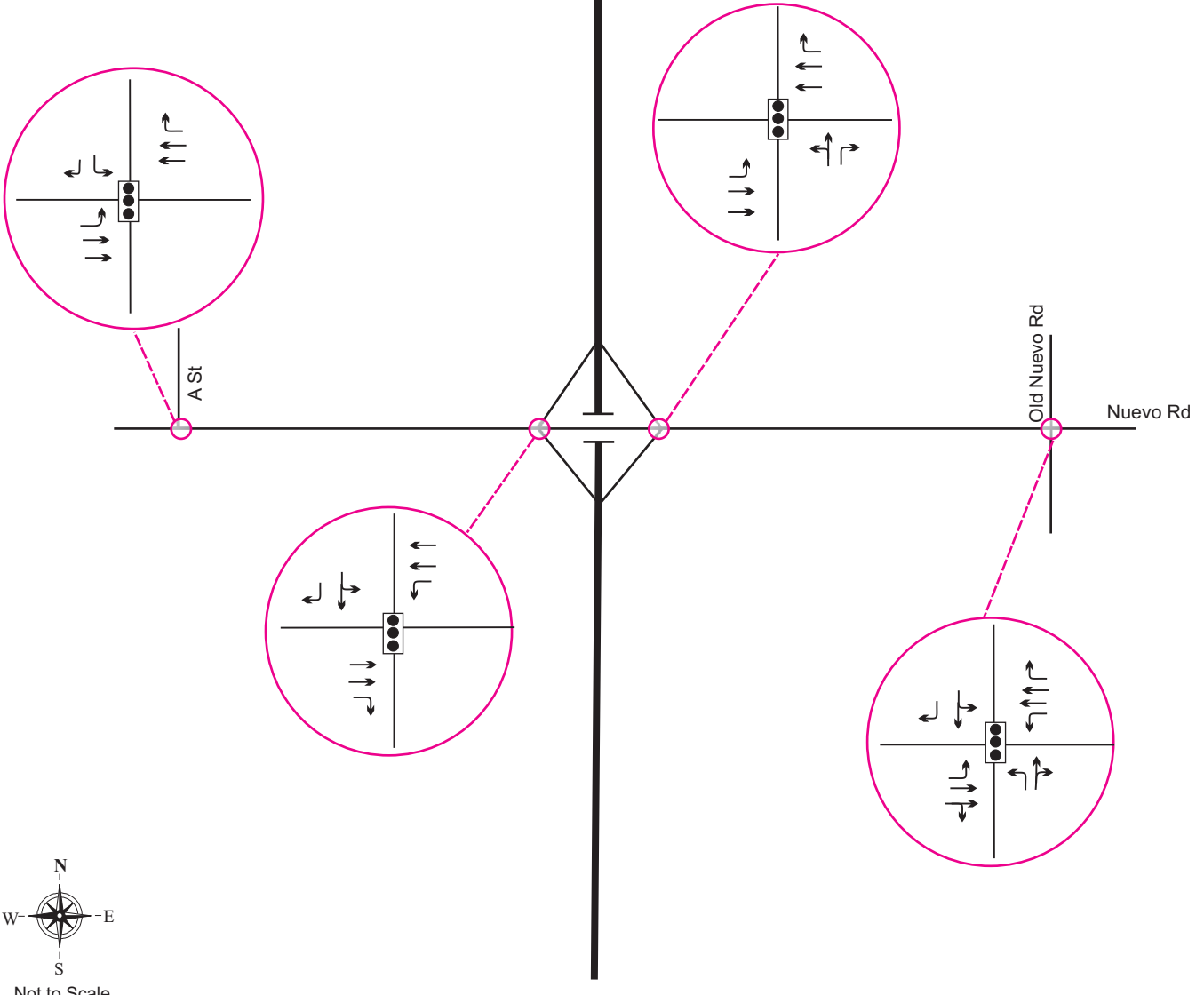

**Opening Year (2020) Intersection
Lane Geometry - Build**

Figure 6-12i

Legend:



Signal



Traffic Lane



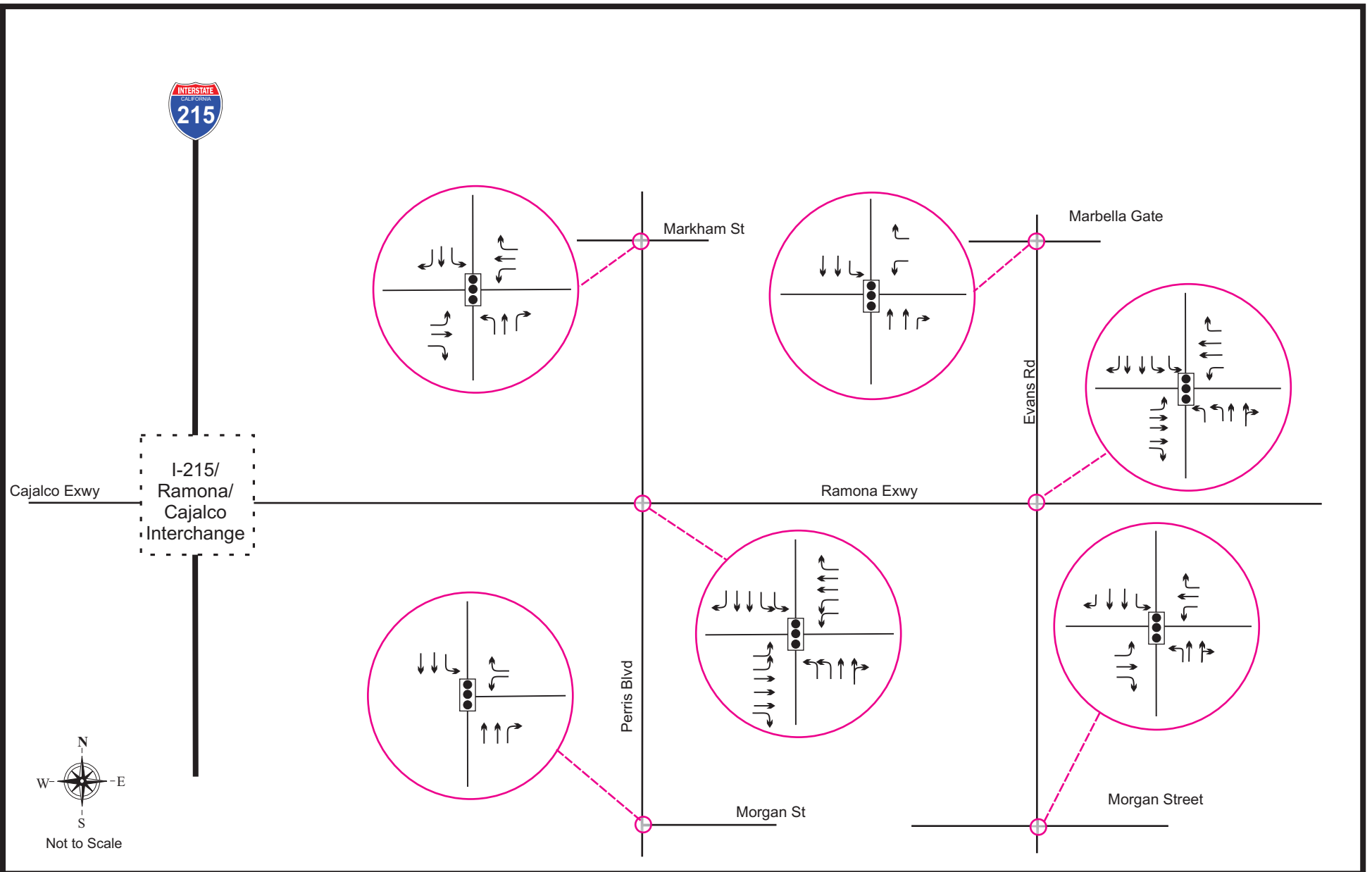

**Opening Year (2020) Intersection
Lane Geometry - Build**

Figure 6-12j

Legend:

-  Signal
-  Traffic Lane



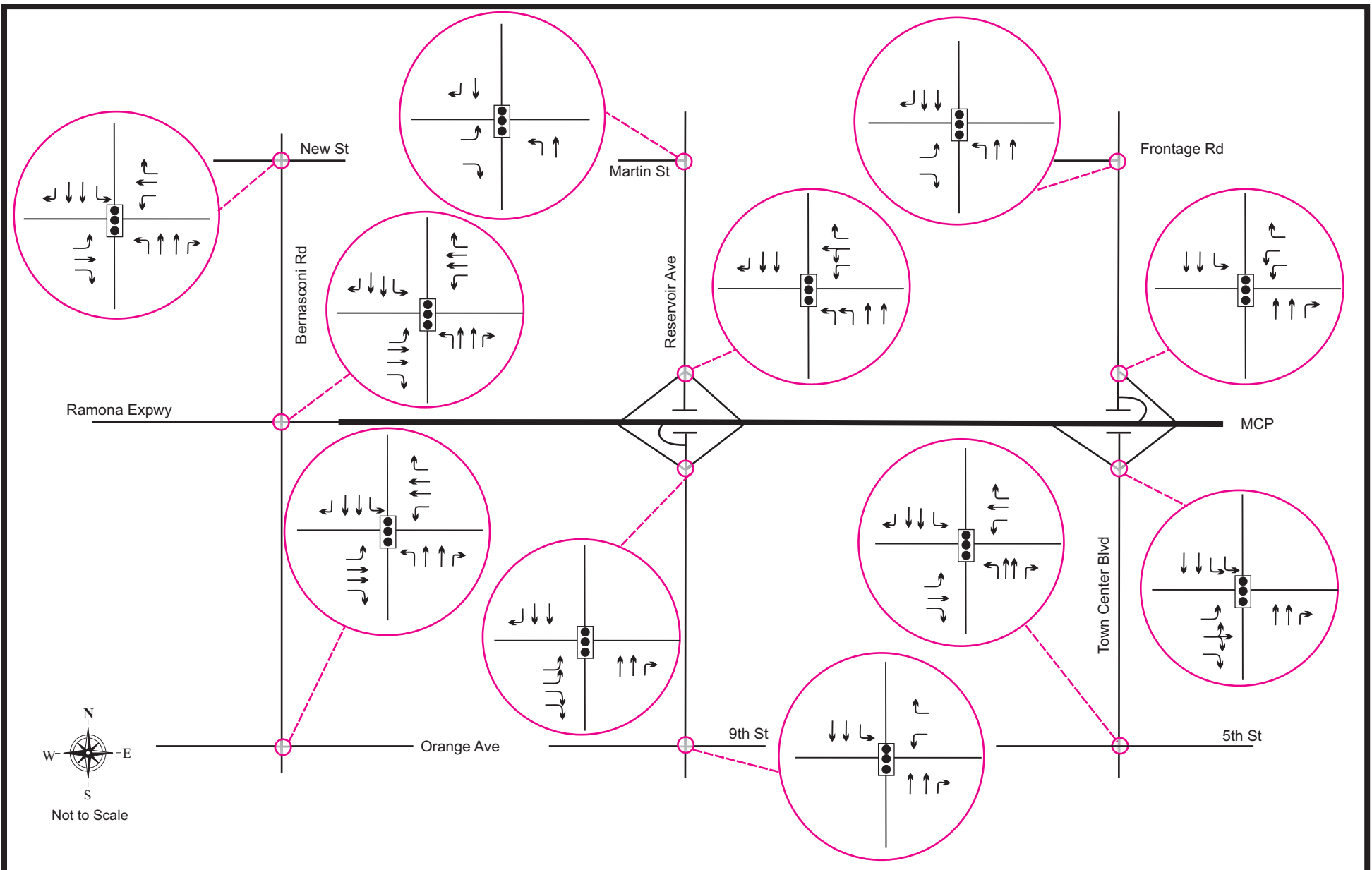

**Opening Year (2020) Intersection
Lane Geometry - Build**

Figure 6-12k

Legend:



Signal



Traffic Lane



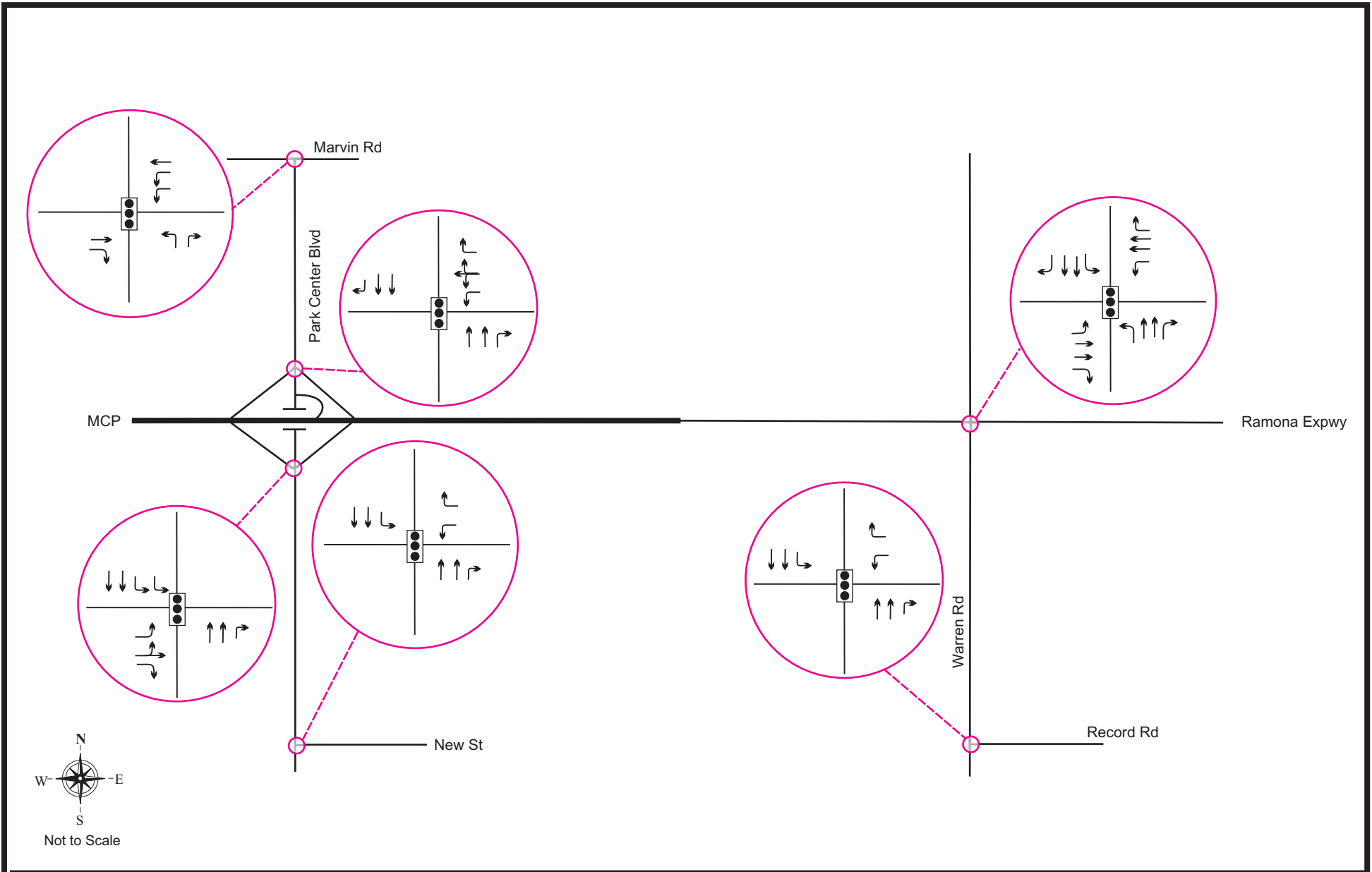

**Opening Year (2020) Intersection
Lane Geometry - Build**

Figure 6-12I

Legend:



Signal



Traffic Lane



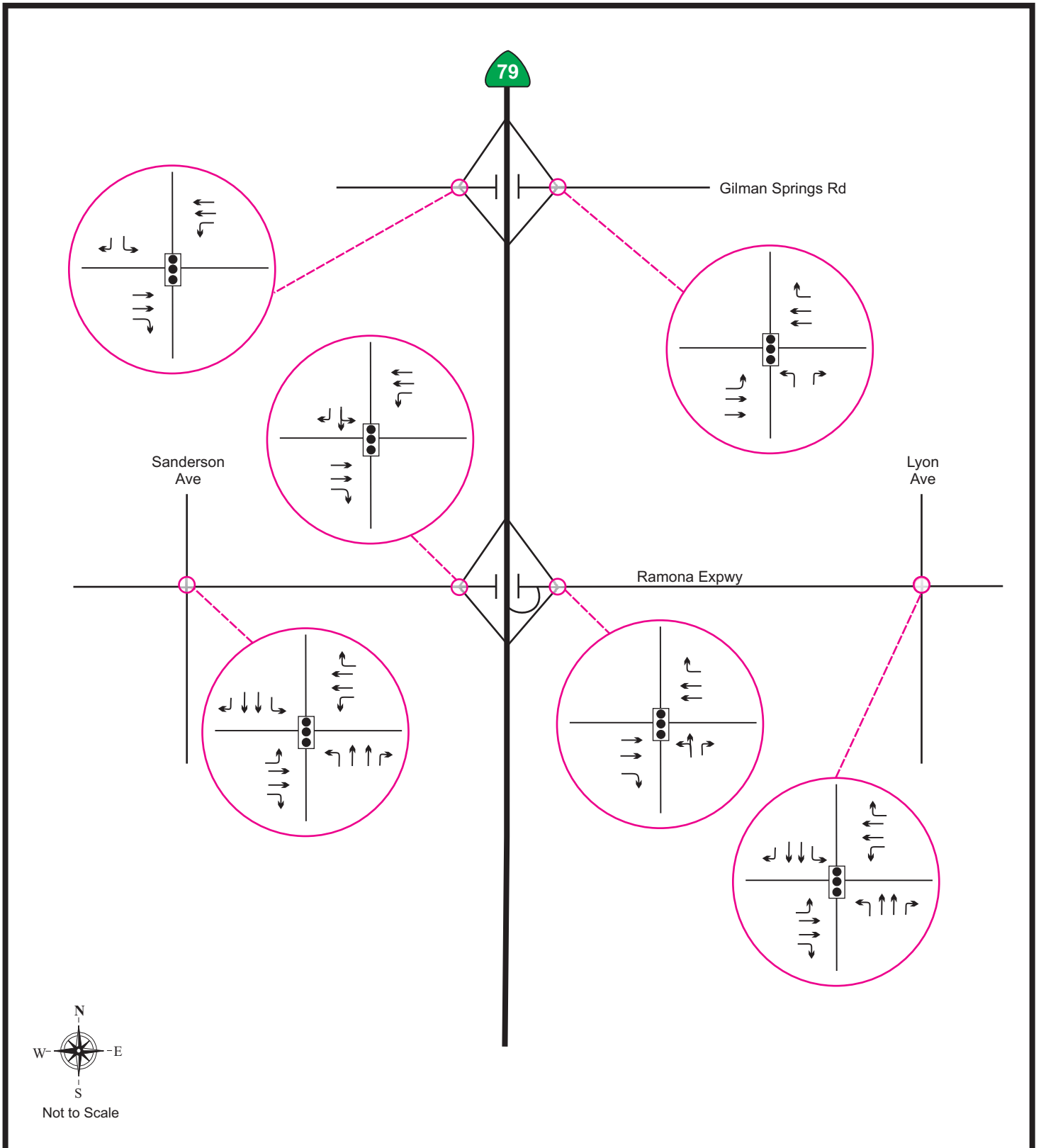

**Opening Year (2020) Intersection
Lane Geometry - Build**

Figure 6-12m

Legend:



Signal



Traffic Lane



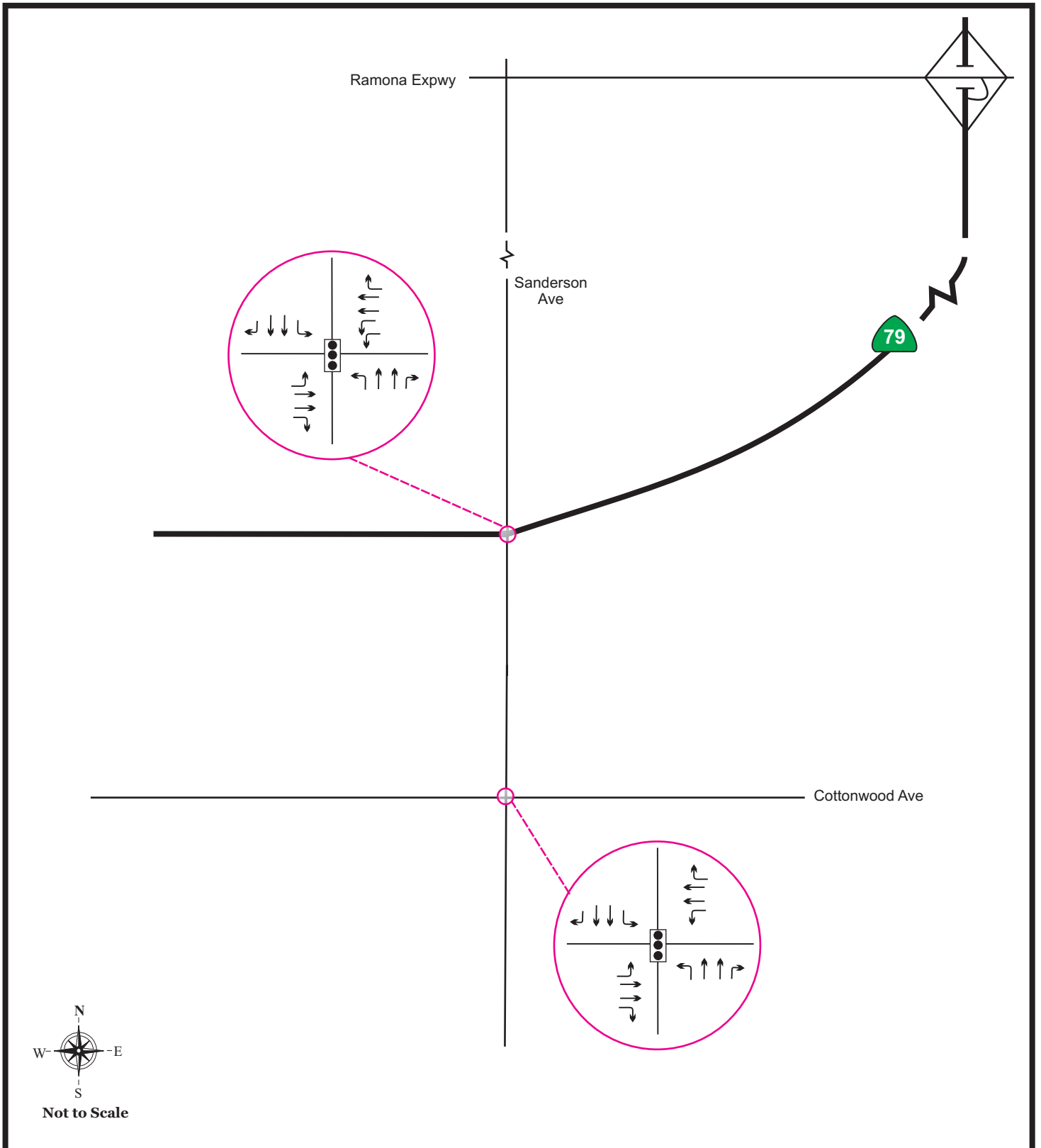

**Opening Year (2020) Intersection
Lane Geometry - Build**

Figure 6-12n

Legend:



Signal



Traffic Lane



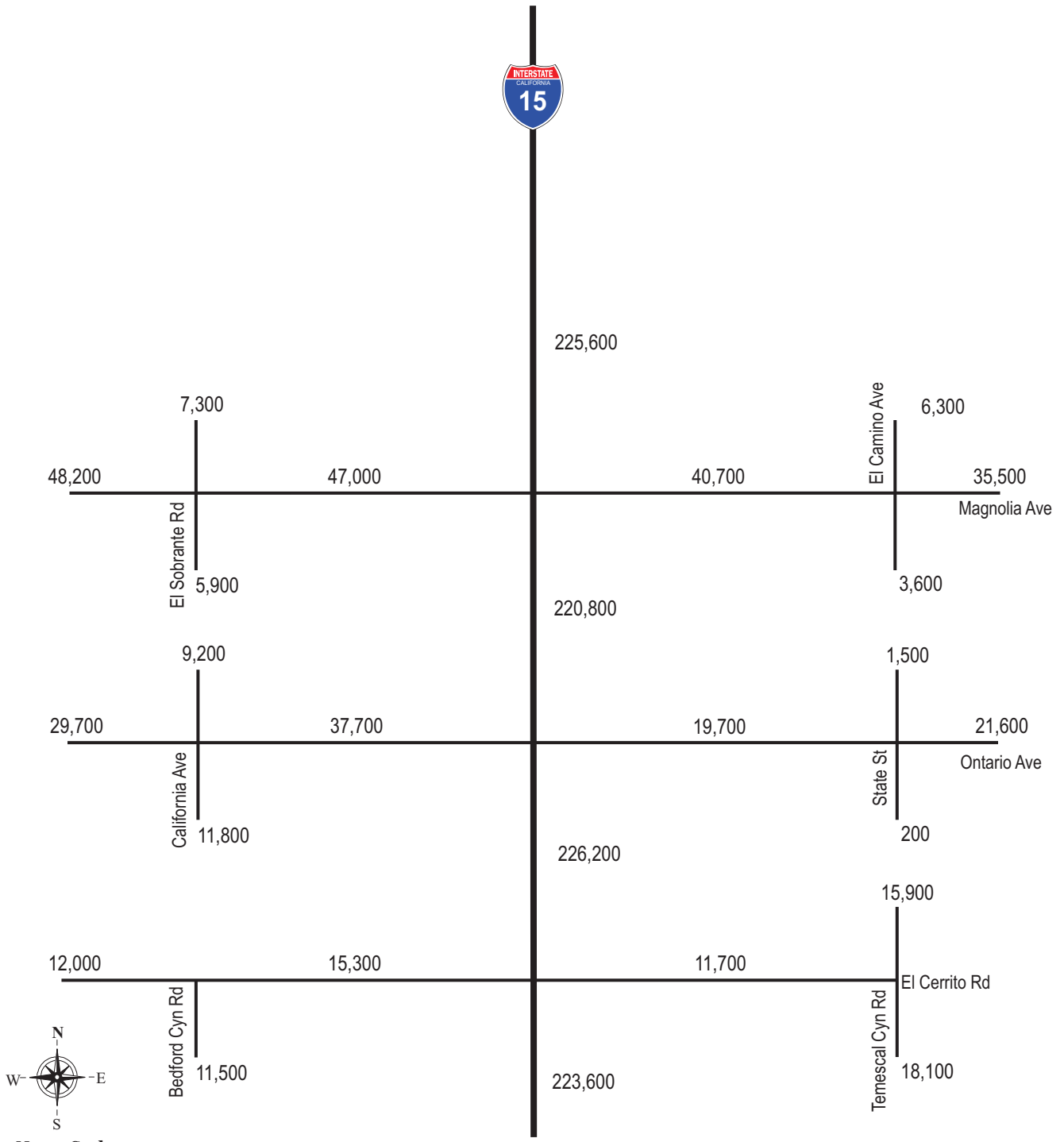

Not to Scale

Opening Year (2020) ADT - Freeway and Street Segments MCP Area - Build

Figure 6-13a

Legend:

XX,XXX Average Daily Traffic



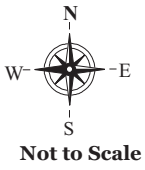
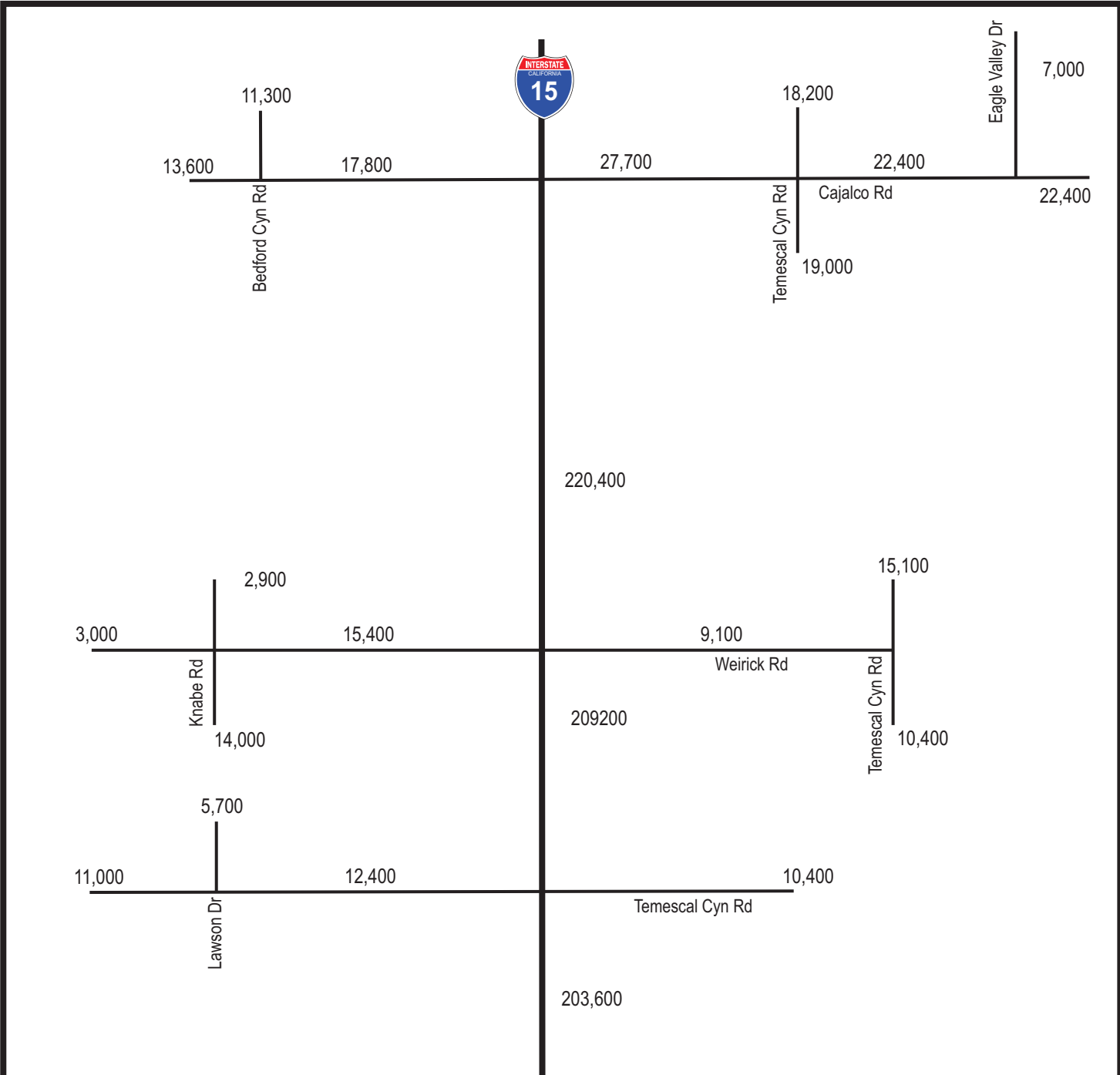

Opening Year (2020) ADT - Freeway and Street Segments MCP Area - Build

Figure 6-13b

Legend:
 XX,XXX Average Daily Traffic





Opening Year (2020) ADT - Freeway and Street Segments MCP Area - Build

Figure 6-13c

Legend:

XX,XXX Average Daily Traffic



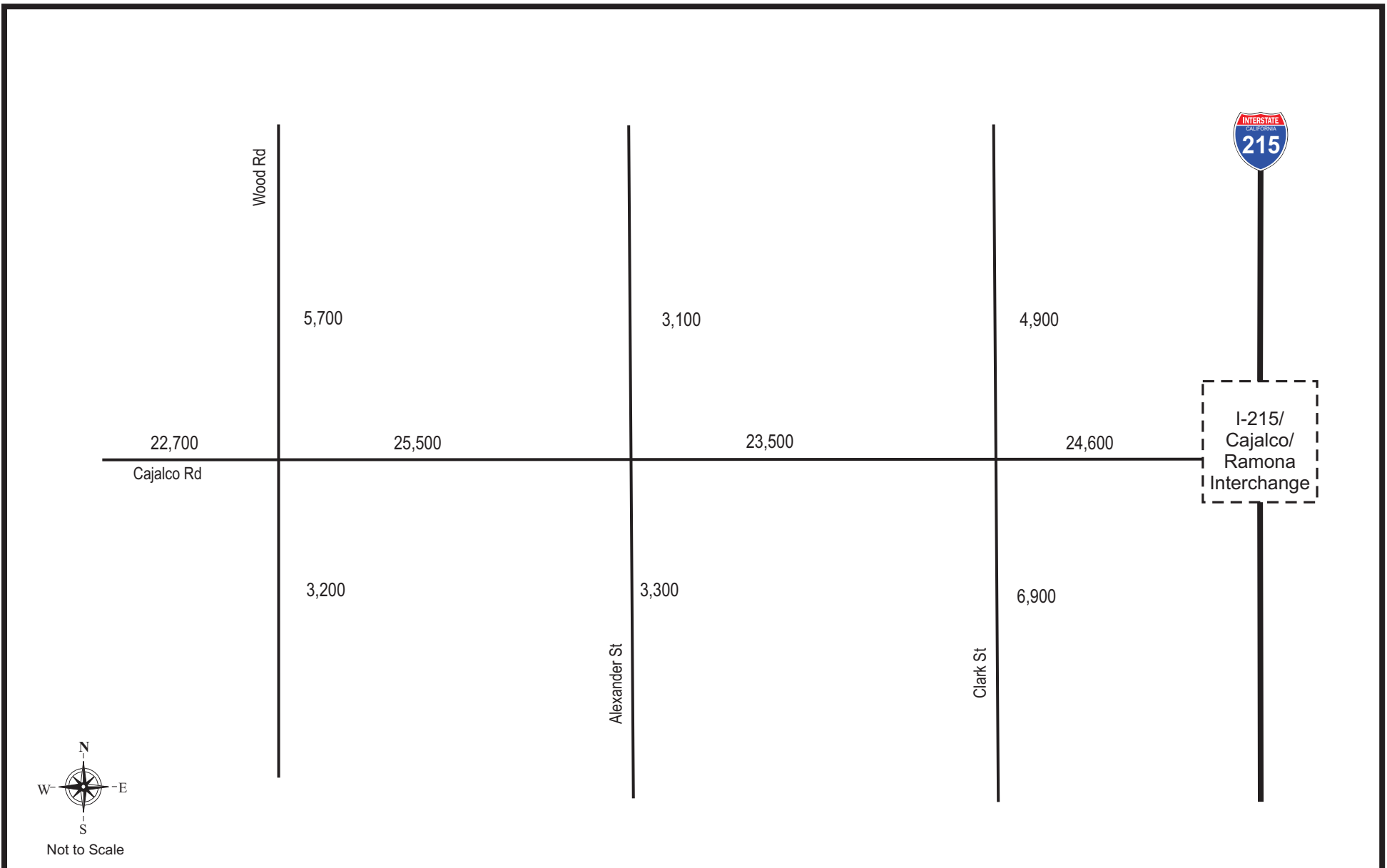

Opening Year (2020) ADT - Freeway and Street Segments MCP Area - Build

Figure 6-13d

Legend:

XX,XXX Average Daily Traffic



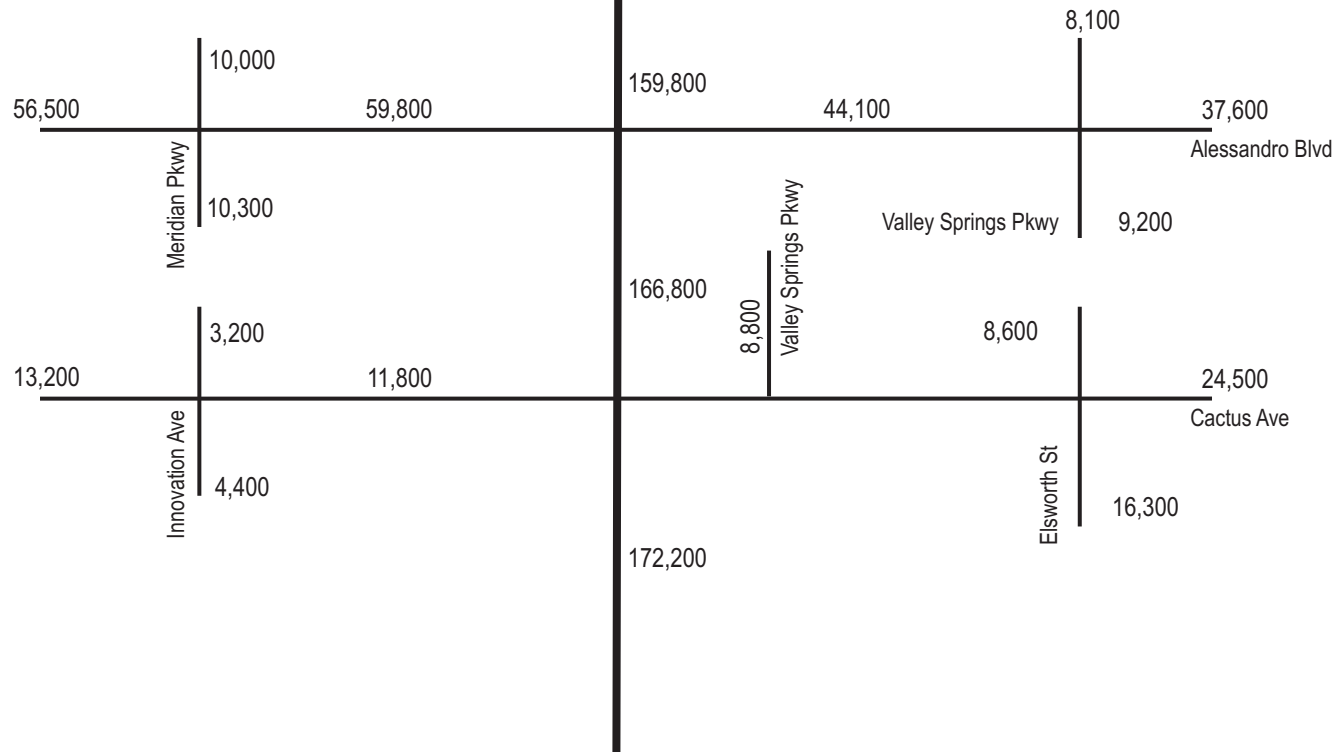

Not to Scale

Opening Year (2020) ADT - Freeway and Street Segments MCP Area - Build

Figure 6-13e

Legend:

XX,XXX Average Daily Traffic





Not to Scale

Opening Year (2020) ADT - Freeway and Street Segments MCP Area - Build

Figure 6-13f

Legend:

XX,XXX Average Daily Traffic



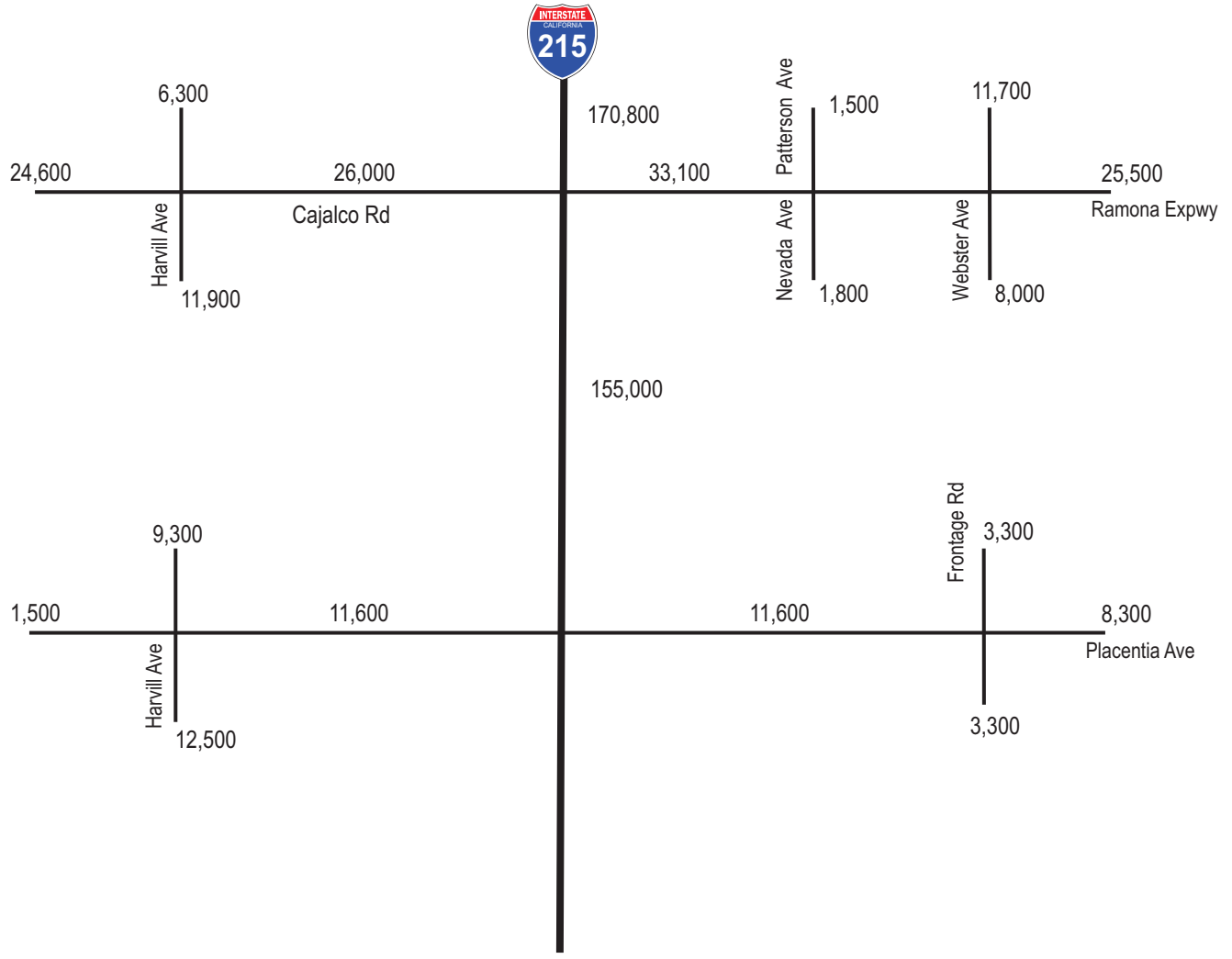

Opening Year (2020) ADT - Freeway and Street Segments MCP Area - Build

Figure 6-13g

Legend:

XX,XXX Average Daily Traffic



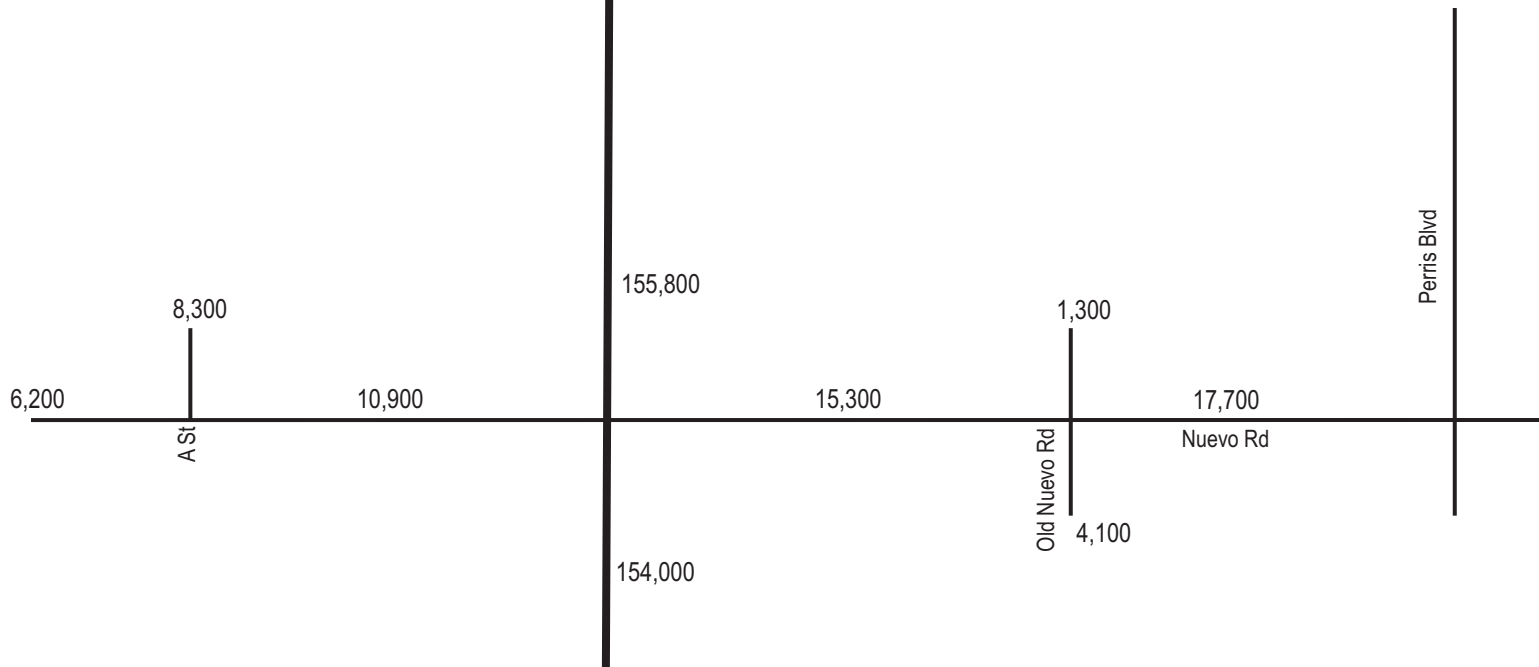

Not to Scale

**Opening Year (2020) ADT - Freeway and Street
Segments MCP Area - Build**

Figure 6-13h

Legend:

XX,XXX Average Daily Traffic



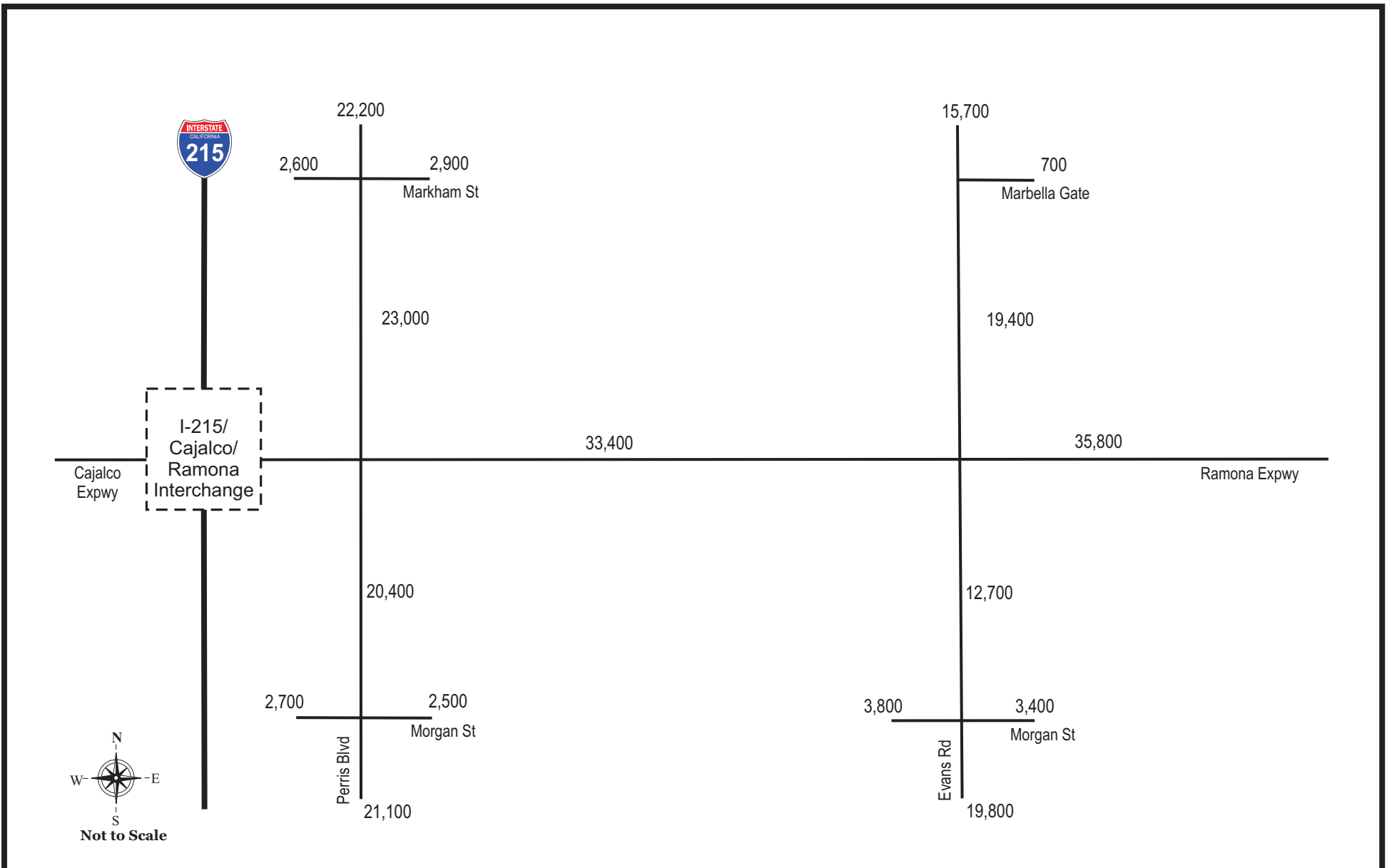

Opening Year (2020) ADT - Freeway and Street Segments MCP Area - Build

Figure 6-13i

Legend:

XX,XXX Average Daily Traffic



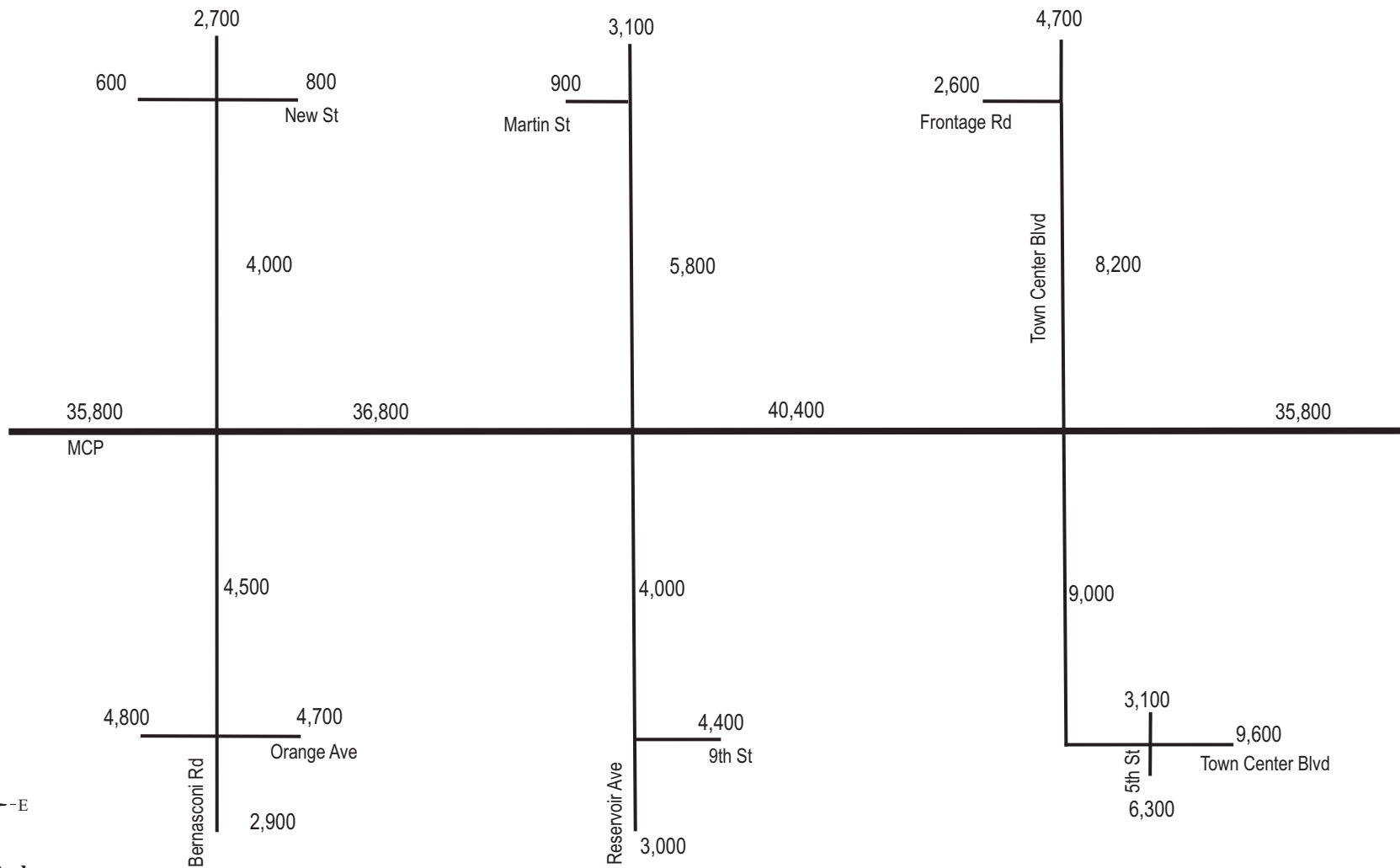

Opening Year (2020) ADT - Freeway and Street Segments MCP Area - Build

Figure 6-13j

Legend:

XX,XXX Average Daily Traffic



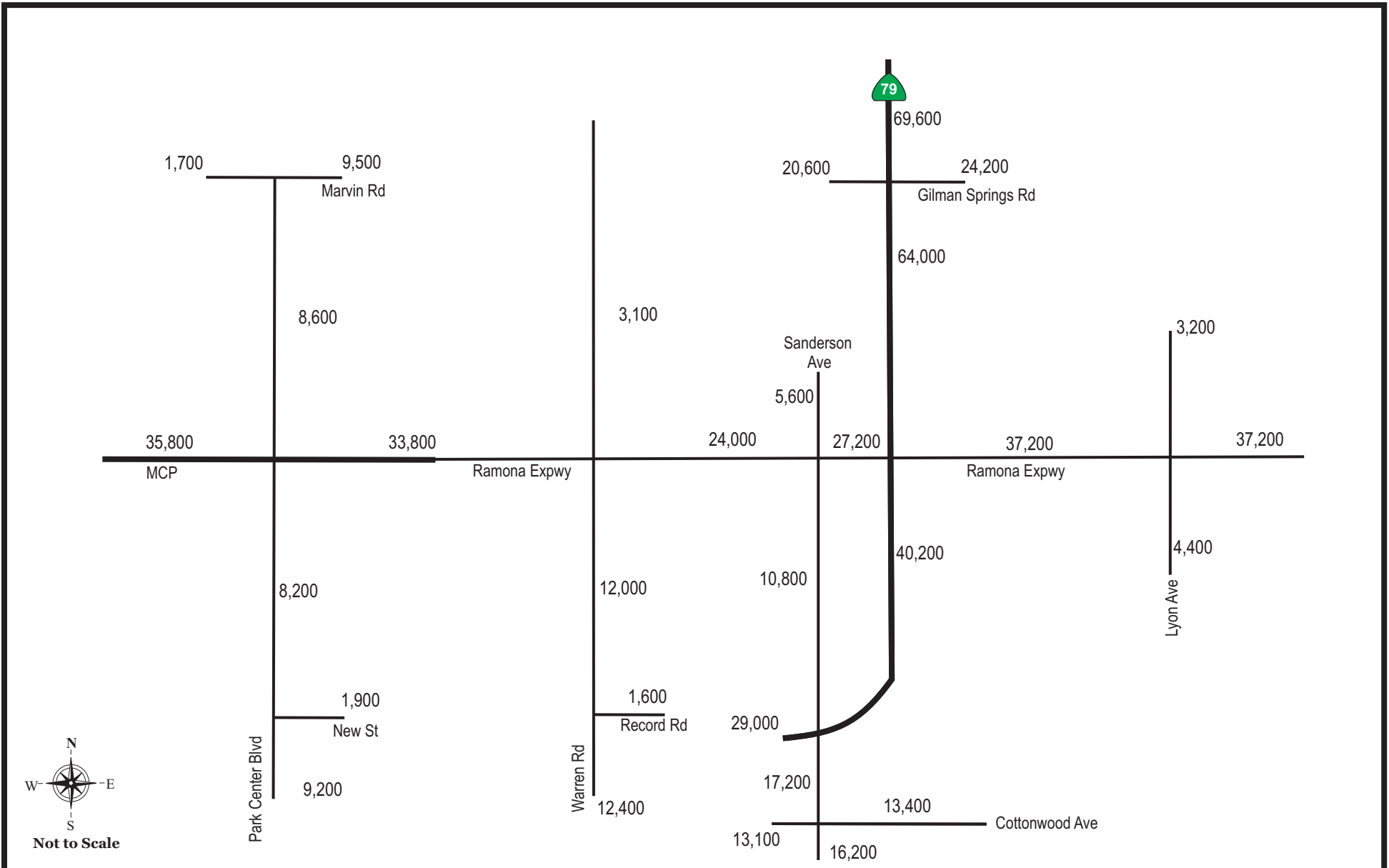

Opening Year (2020) ADT - Freeway and Street Segments MCP Area - Build

Figure 6-13k

Legend:

XX,XXX Average Daily Traffic



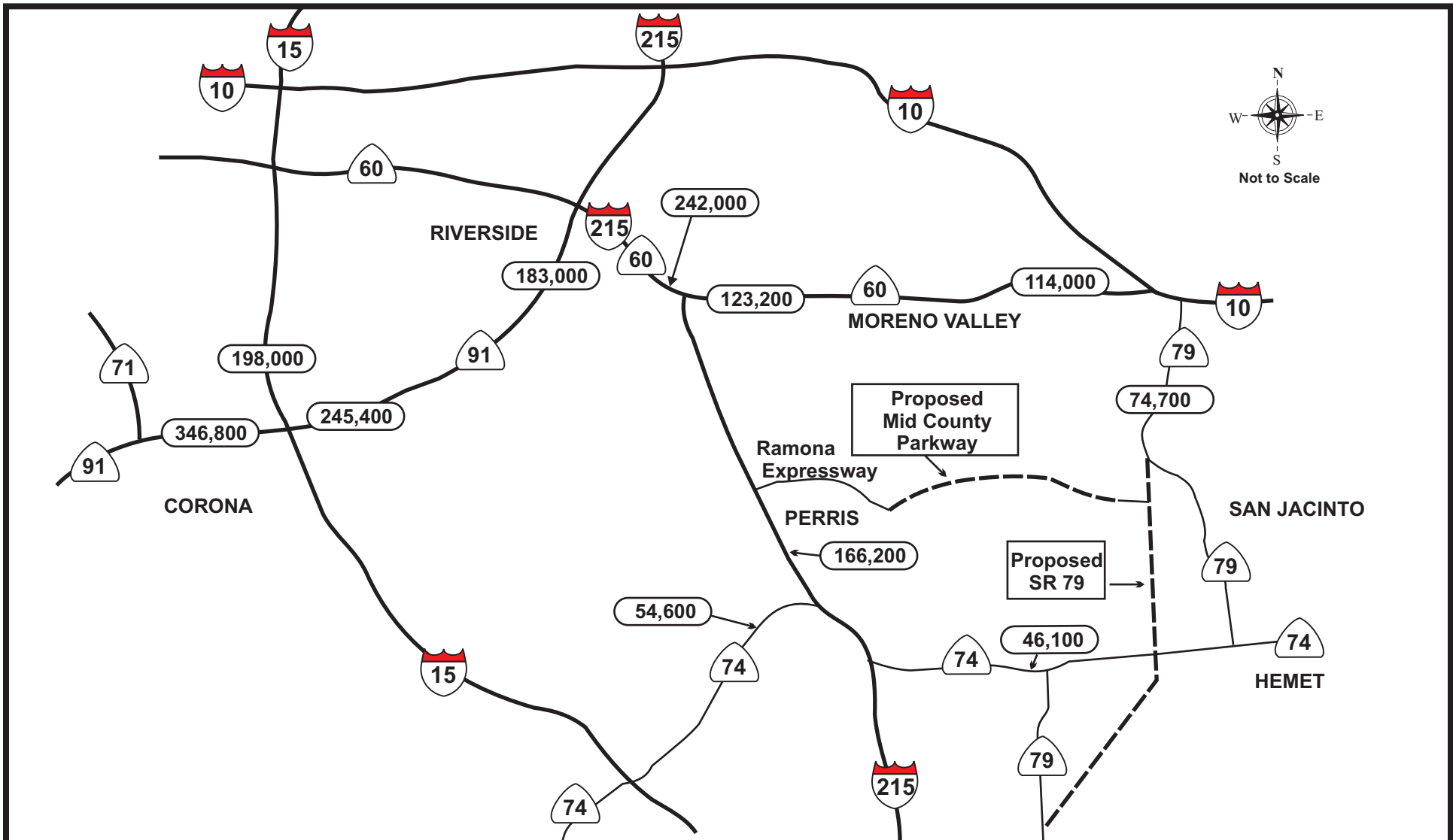

**Opening Year (2020) ADT Freeway and Street Segments
Outside MCP Area - Build**

Figure 6-14

Legend

- Existing Limited Access Roadway
- Existing Arterial Roadway
- - - Proposed Limited Access Roadway
- (XXX,XXX) Average Daily Traffic



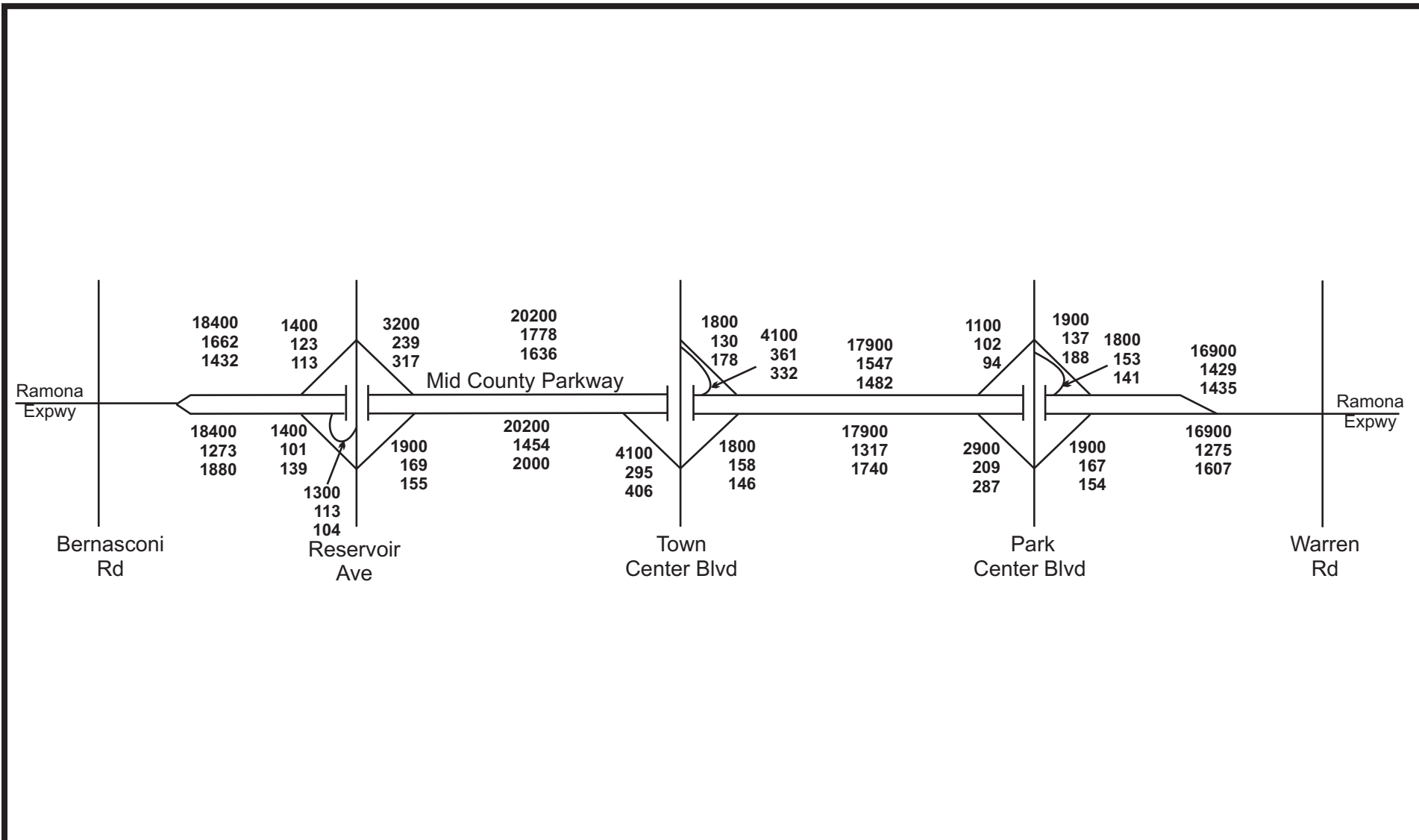

**Opening Year (2020) Freeway and Ramp Traffic
Mid County Parkway - Build**

Figure 6-15

Legend

- XXXXX Average Daily Traffic
- XXXX AM Peak Hour
- XXXX PM Peak Hour



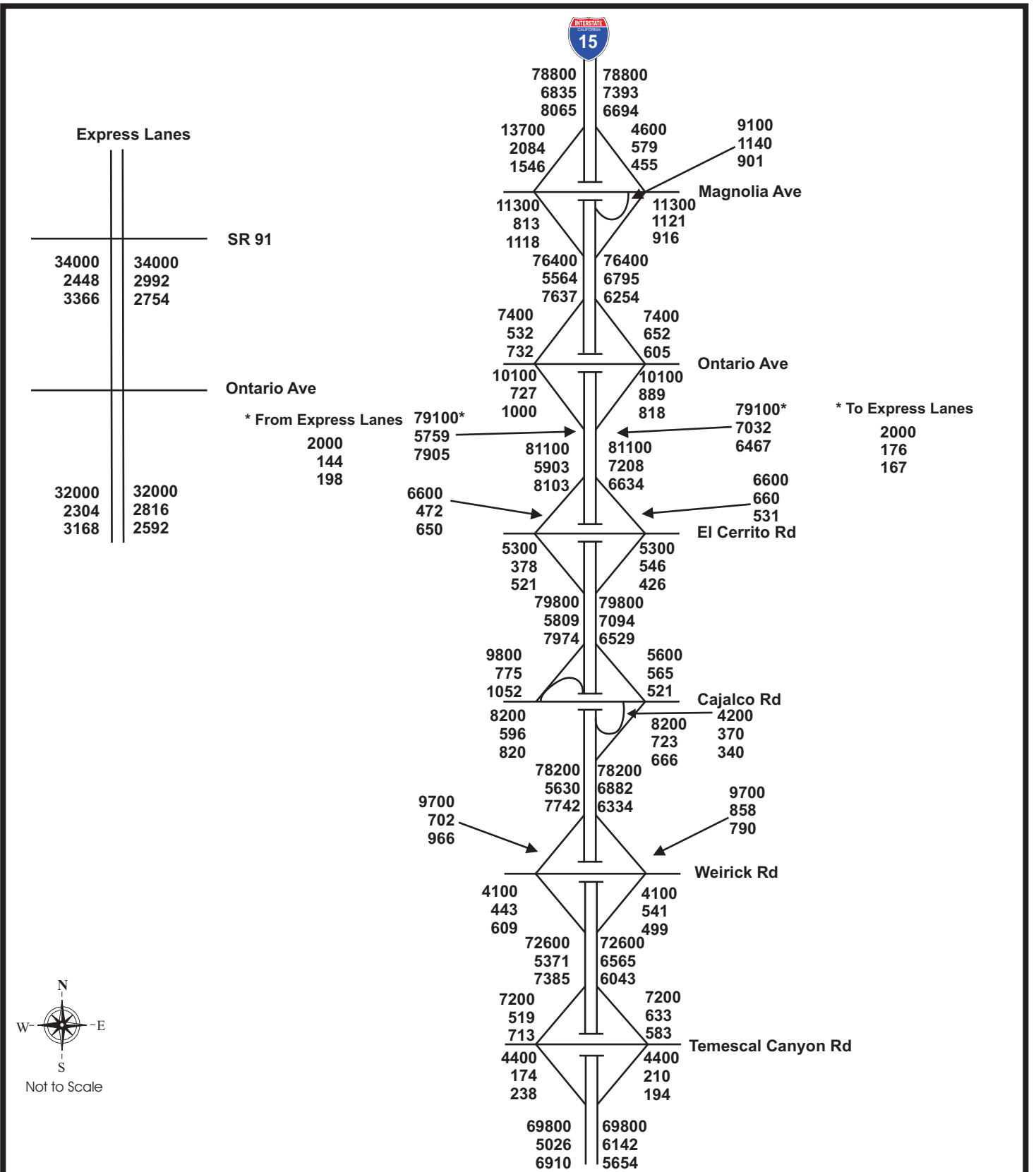

**Opening Year (2020) Freeway and Ramp Traffic
Interstate 15 - Build**

Figure 6-16

Legend

- XXXXX ADT
- XXXX AM Peak Hour
- XXXX PM Peak Hour



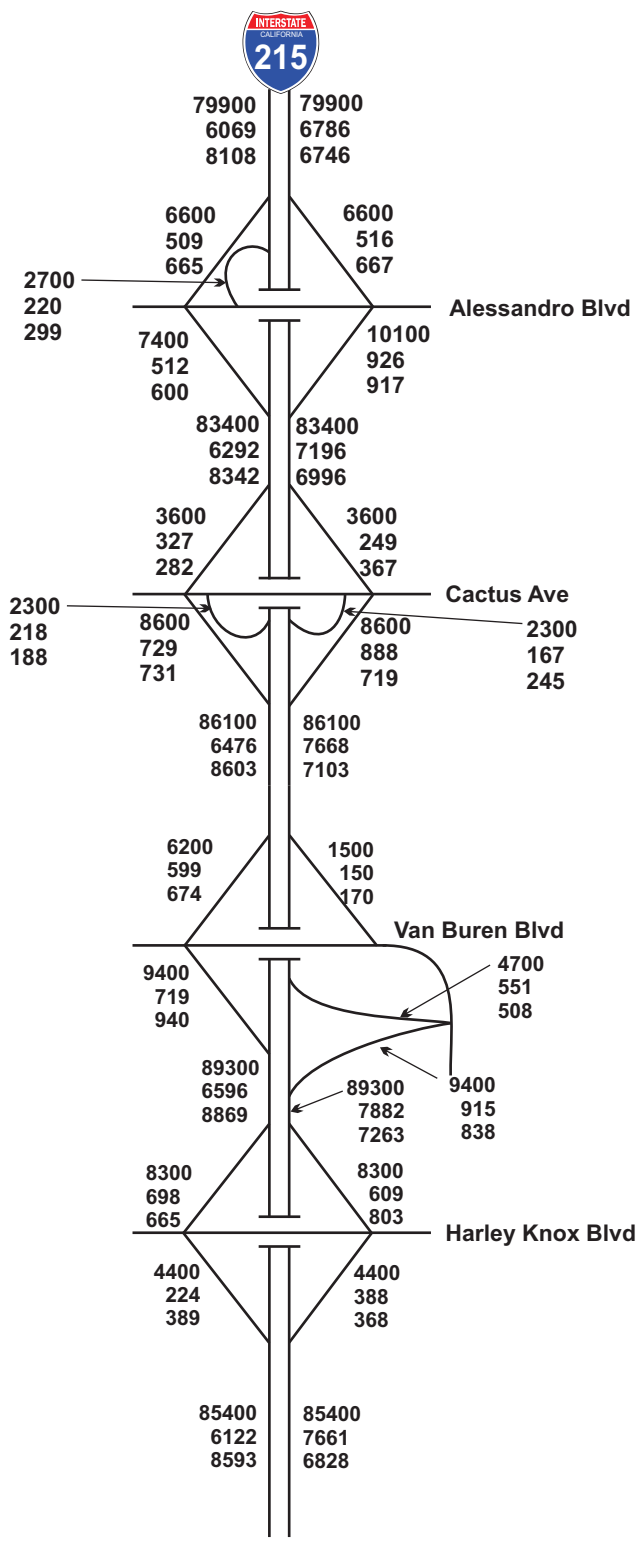

Not to Scale

Opening Year (2020) Freeway and Ramp Traffic Interstate 215 - Build

Figure 6-17a

Legend

- XXXXX Average Daily Traffic
- XXX AM Peak Hour Traffic
- XXX PM Peak Hour Traffic



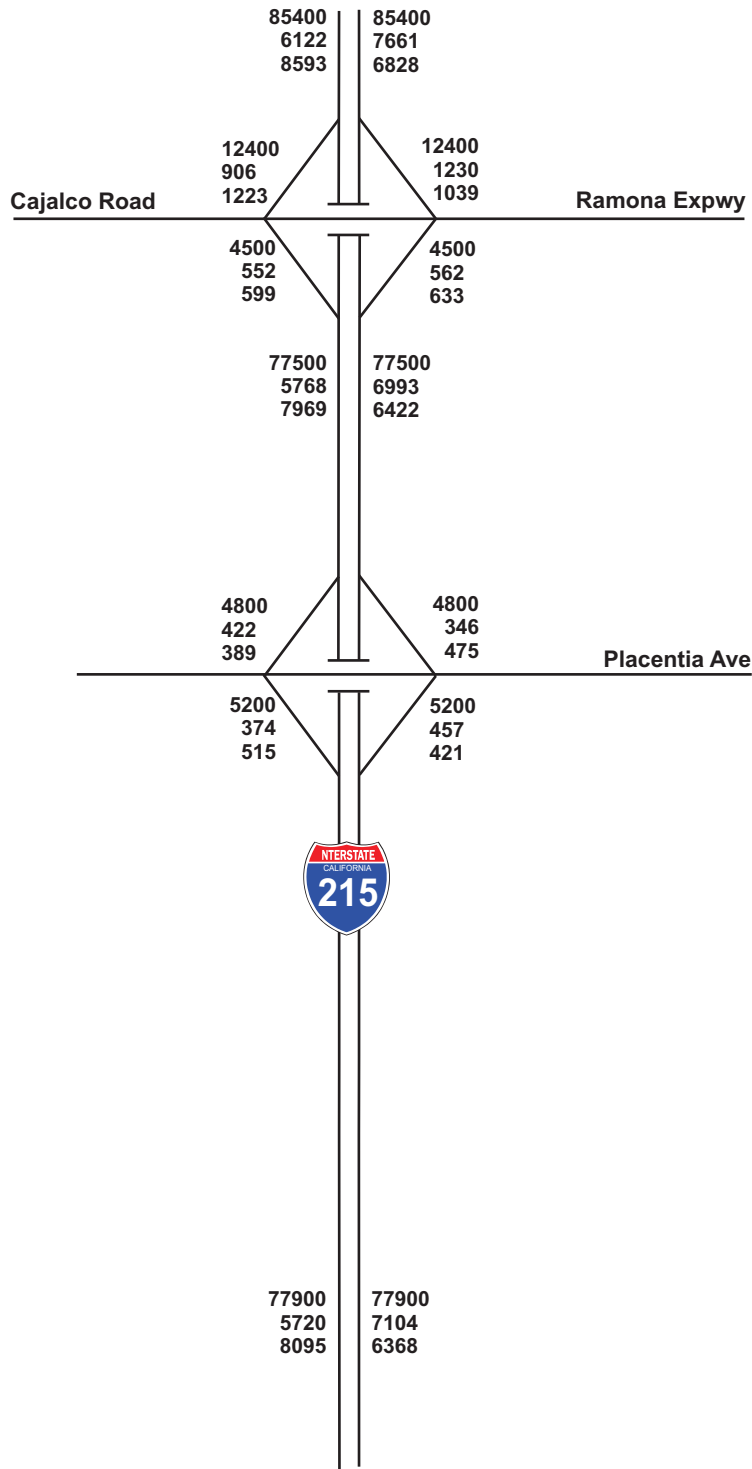

Not to Scale

**Opening Year (2020)
Freeway and Ramp Traffic
Interstate 215 - Build**

Figure 6-17b

Legend

- XXXXX Average Daily Traffic
- XXX AM Peak Hour Traffic
- XXX PM Peak Hour Traffic



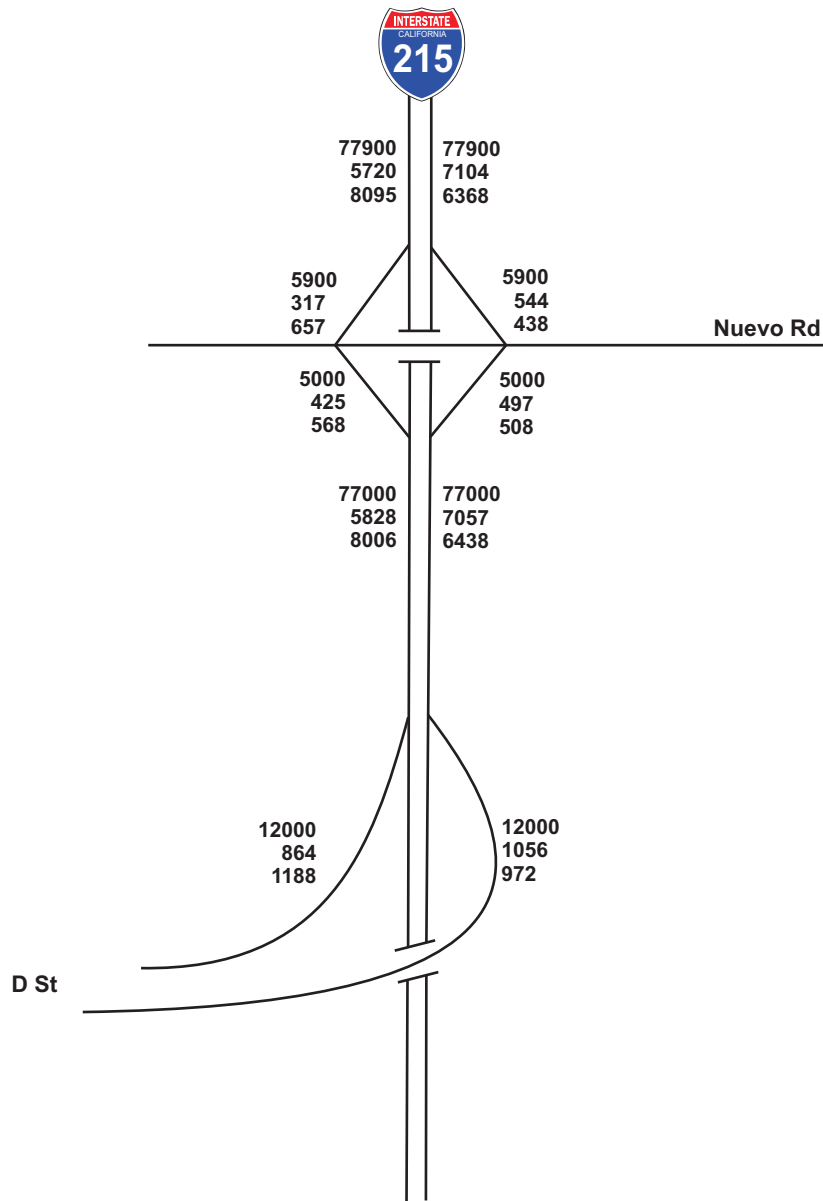

**Opening Year (2020)
Freeway and Ramp Traffic
Interstate 215 - Build**

Figure 6-17c

Legend

- XXXXX Average Daily Traffic
- XXX AM Peak Hour Traffic
- XXX PM Peak Hour Traffic



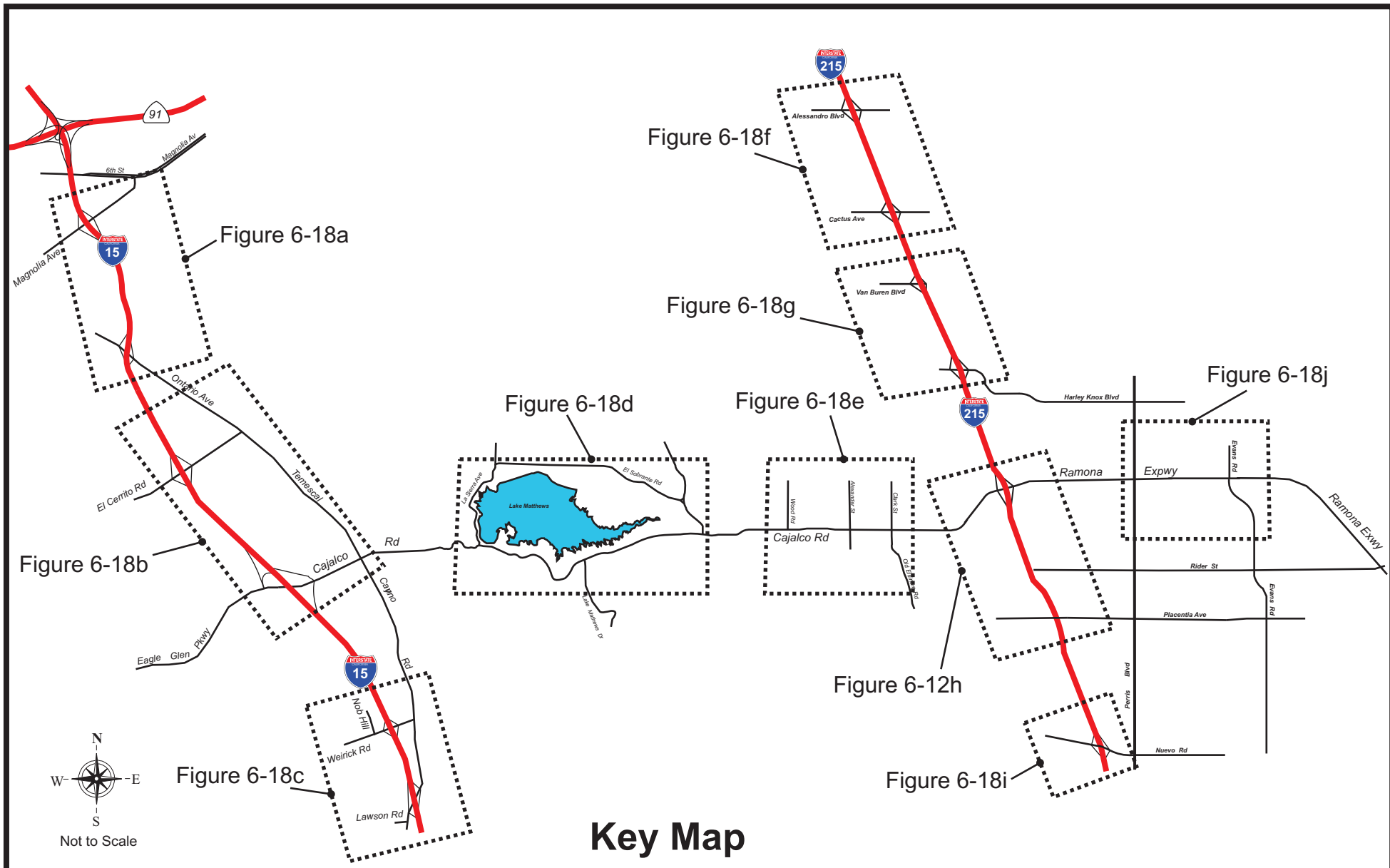

Key Map

Horizon Year (2020) AM/PM Peak Hour Traffic - Intersections Build

Figure 6-18

Legend:

 Figure Areas



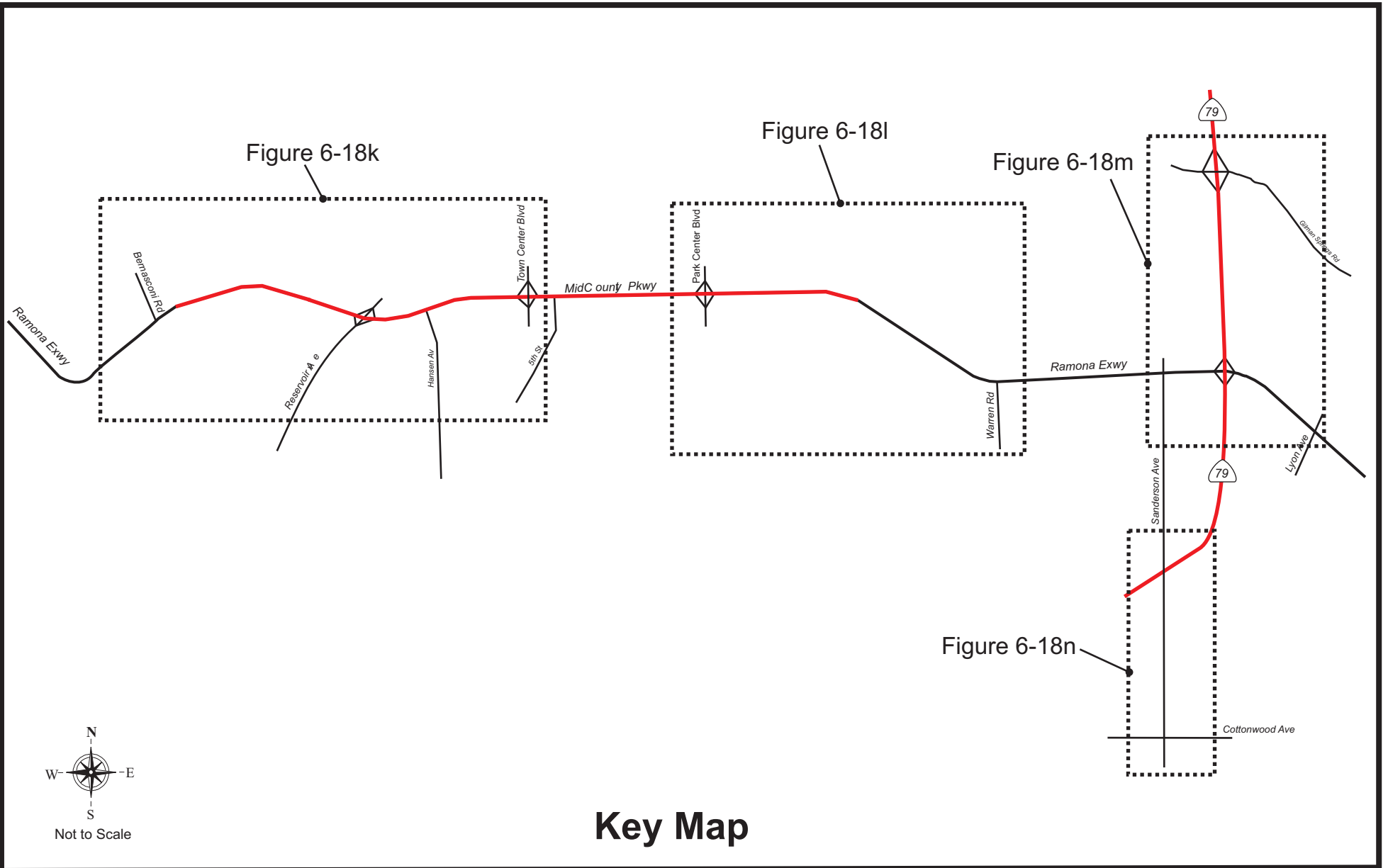

Key Map

Horizon Year (2020) AM/PM Peak Hour Traffic - Intersection Build

Figure 6-18 (cont.)

Legend:

 Figure Areas



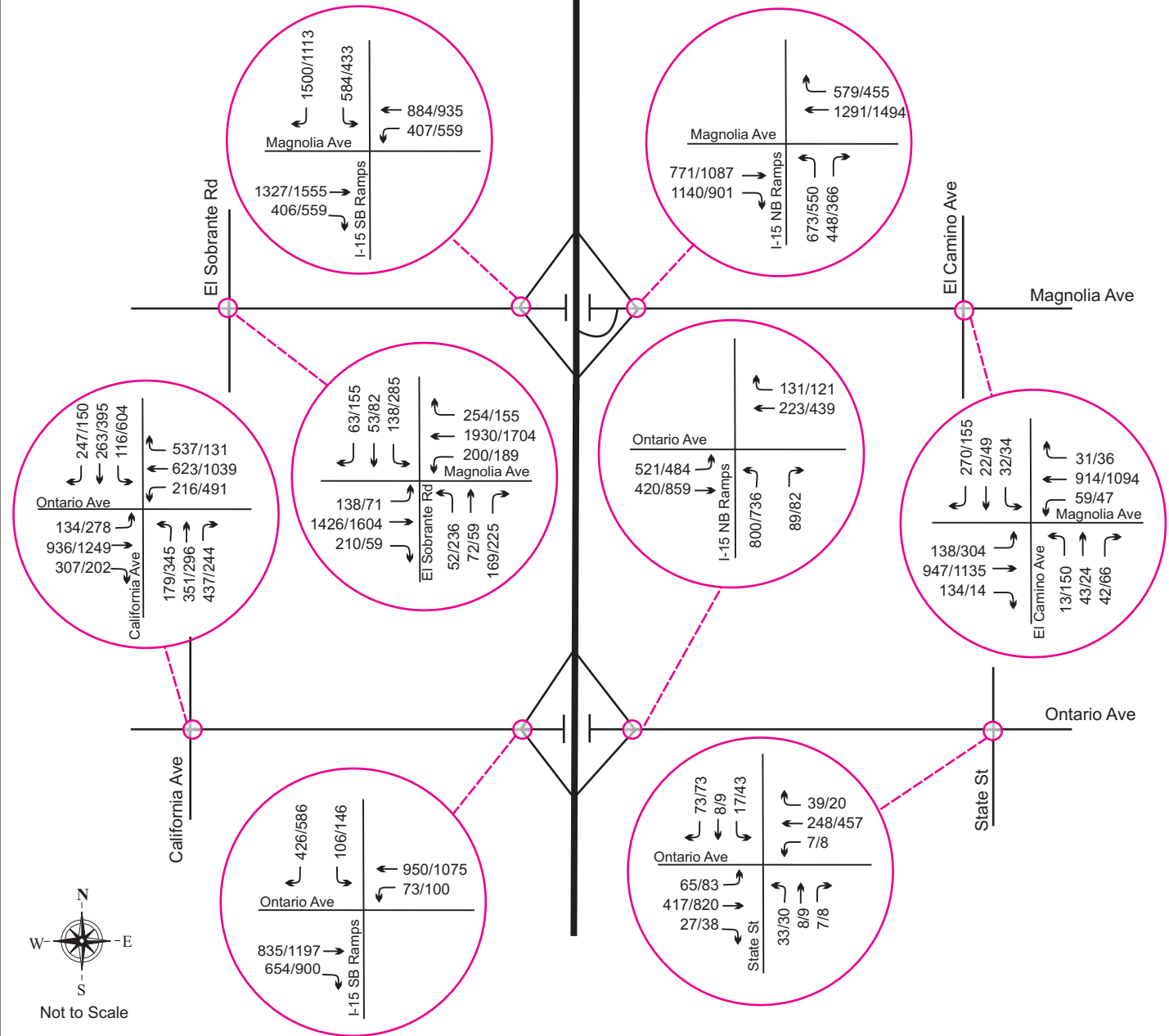

Opening Year (2020) AM/PM Peak Hour Traffic Intersections - Build

Figure 6-18a

XXX/XXX AM/PM Peak Hour



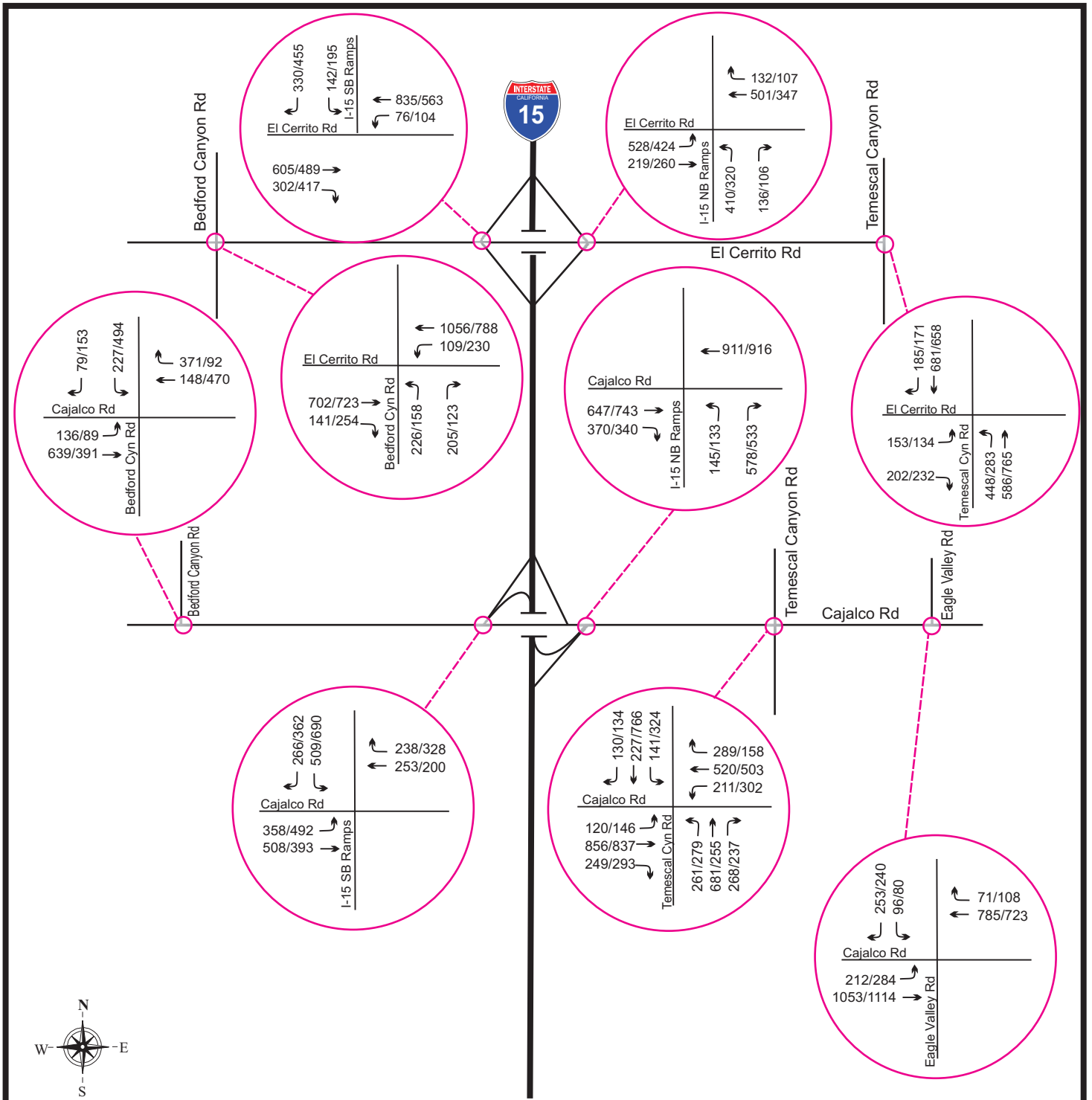

Opening Year (2020) AM/PM Peak Hour Traffic Intersections - Build

Figure 6-18b

XXX/XXX AM/PM Peak Hour



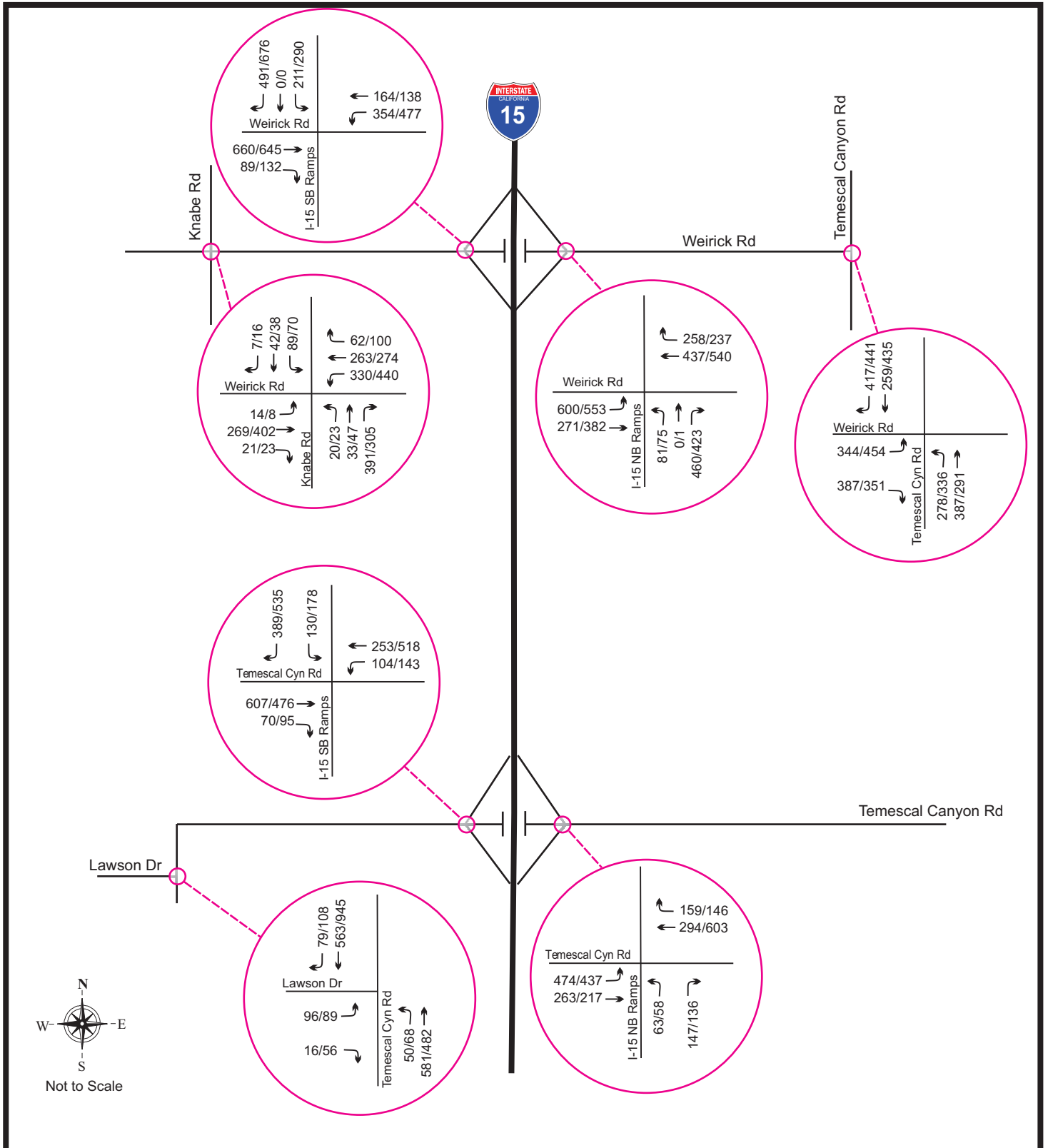

Opening Year (2020) AM/PM Peak Hour Traffic Intersections - Build

Figure 6-18c

XXX/XXX AM/PM Peak Hour



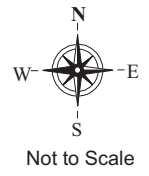
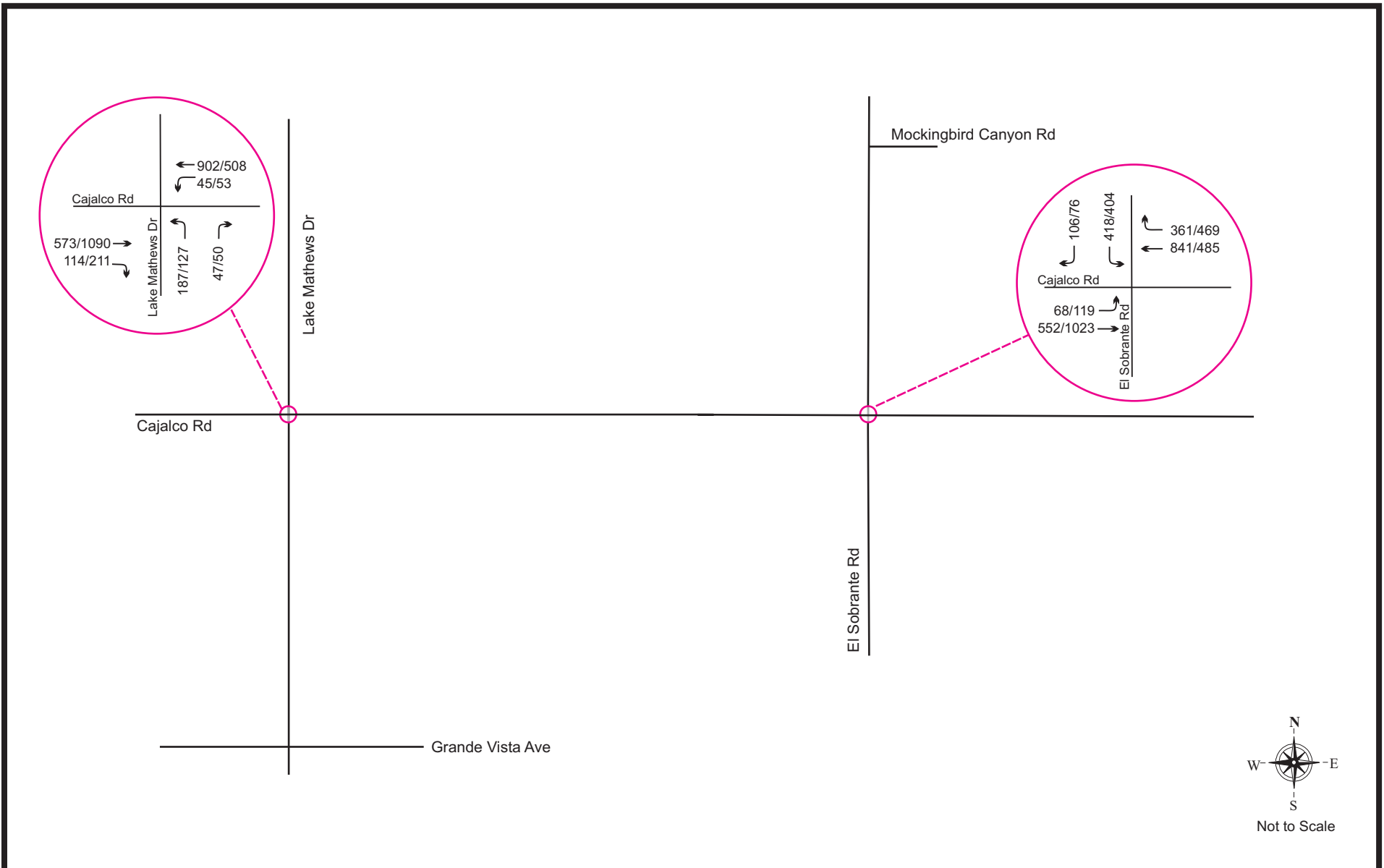

**Horizon Year (2020) AM/PM Peak Hour Traffic Intersections
Build**

Figure 6-18d

XXX/XXX AM/PM Peak Hour



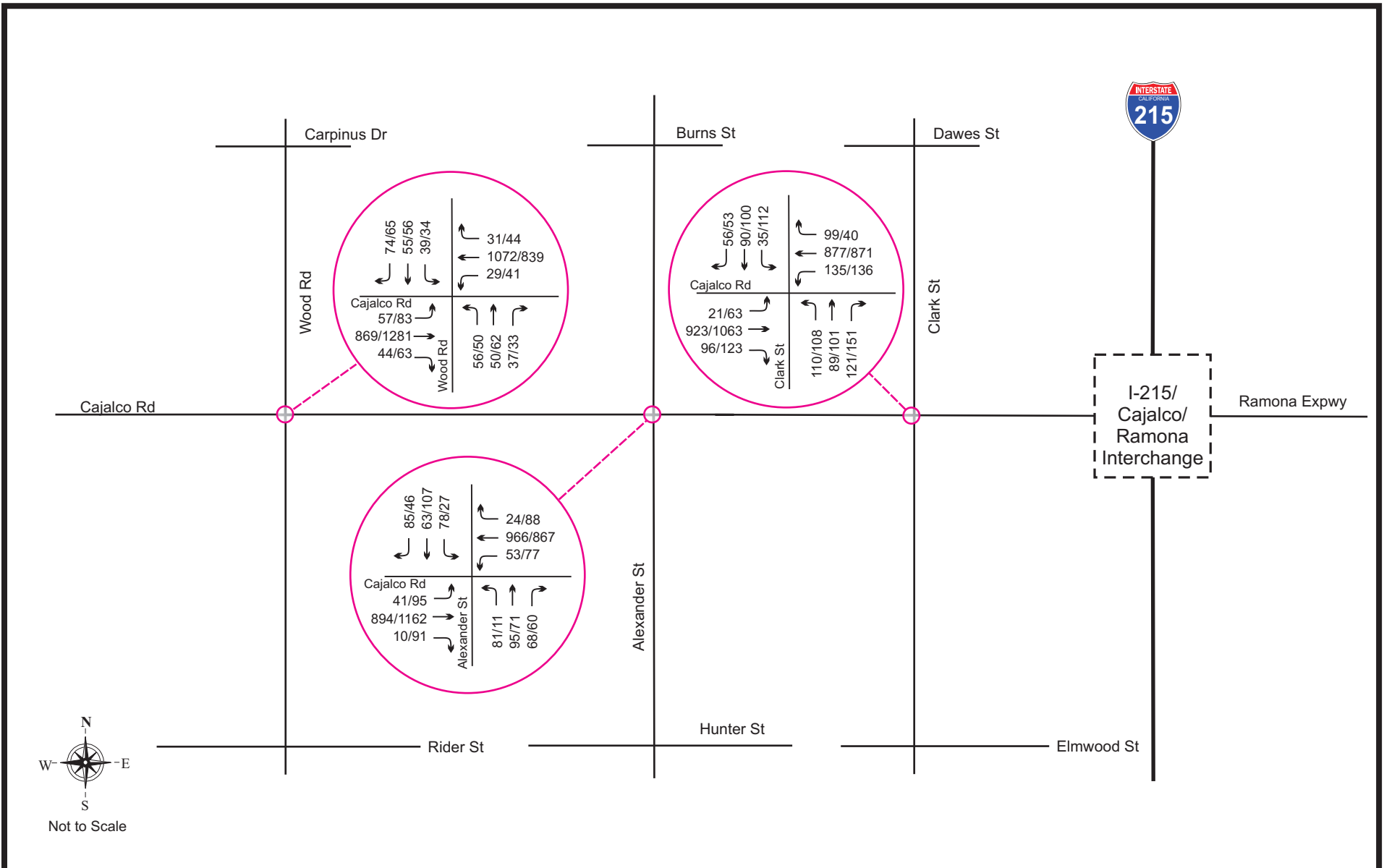

**Horizon Year (2020) AM/PM Peak Hour Traffic Intersections
Build**

Figure 6-18e

XXX/XXX AM/PM Peak Hour



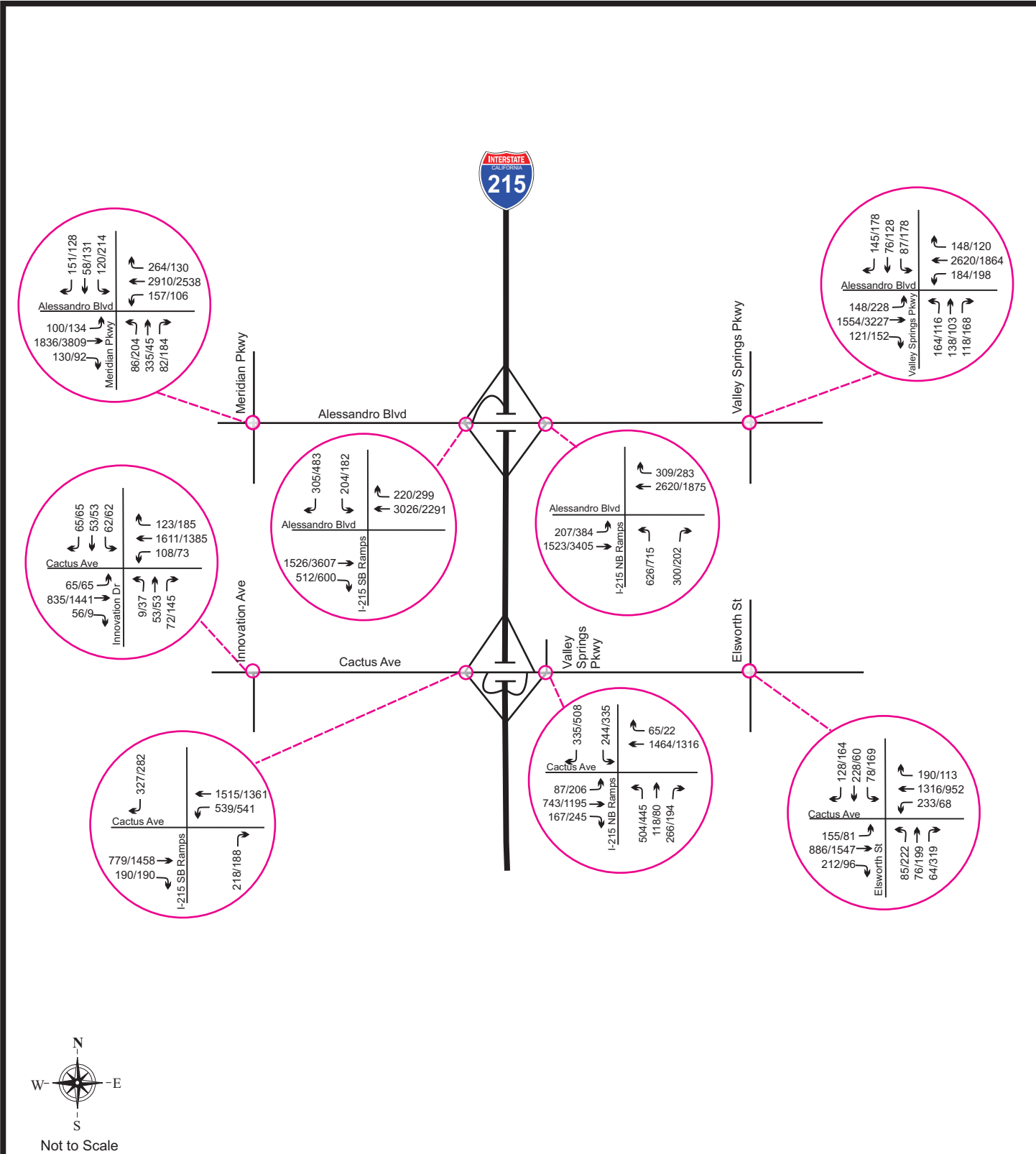

Horizon Year (2020) AM/PM Peak Hour Traffic Intersections - Build

Figure 6-18f

XXX/XXX AM/PM Peak Hour



VRPA TECHNOLOGIES, INC.

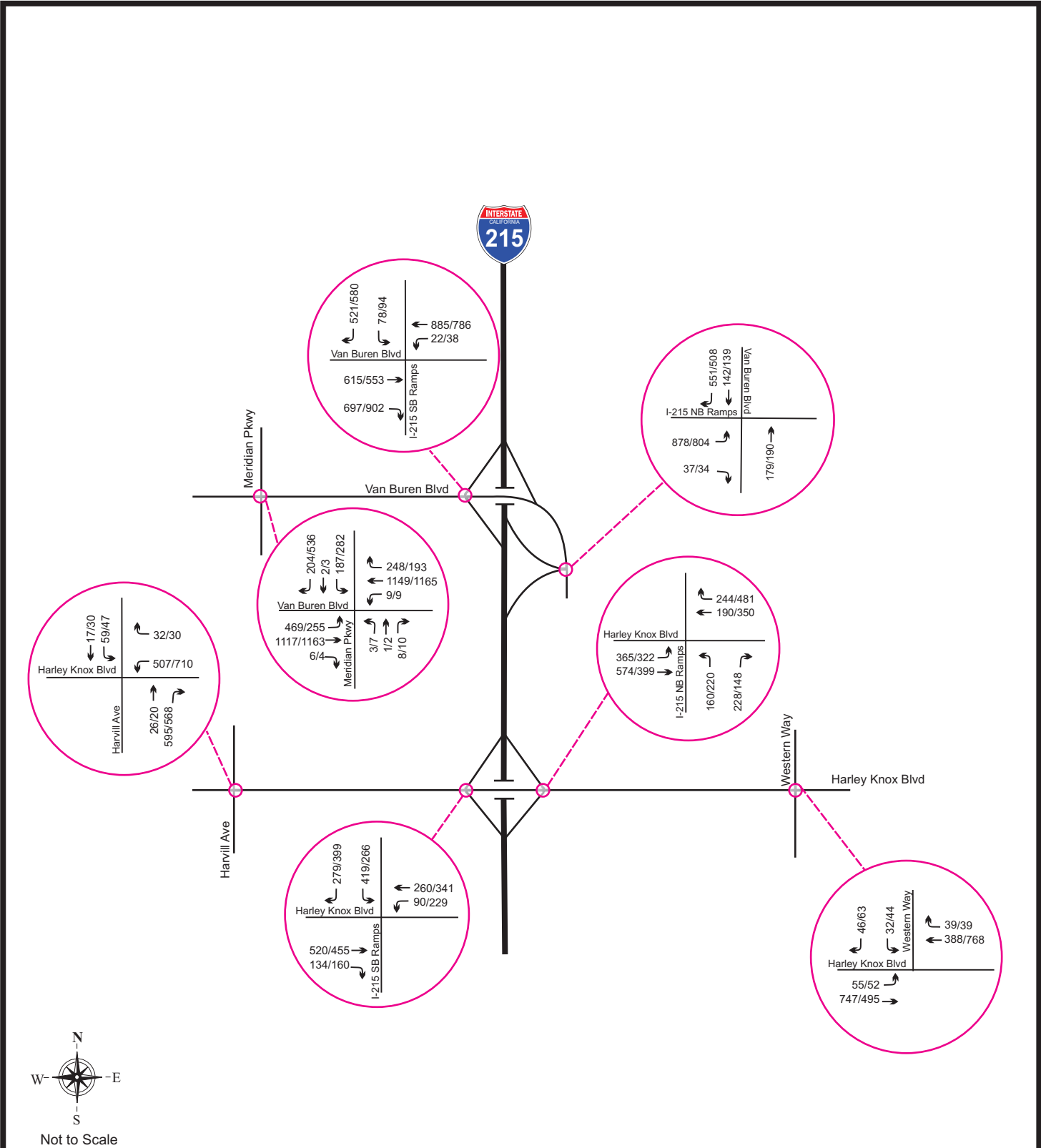

Horizon Year (2020) AM/PM Peak Hour Traffic Intersections - Build

Figure 6-18g

XXX/XXX AM/PM Peak Hour



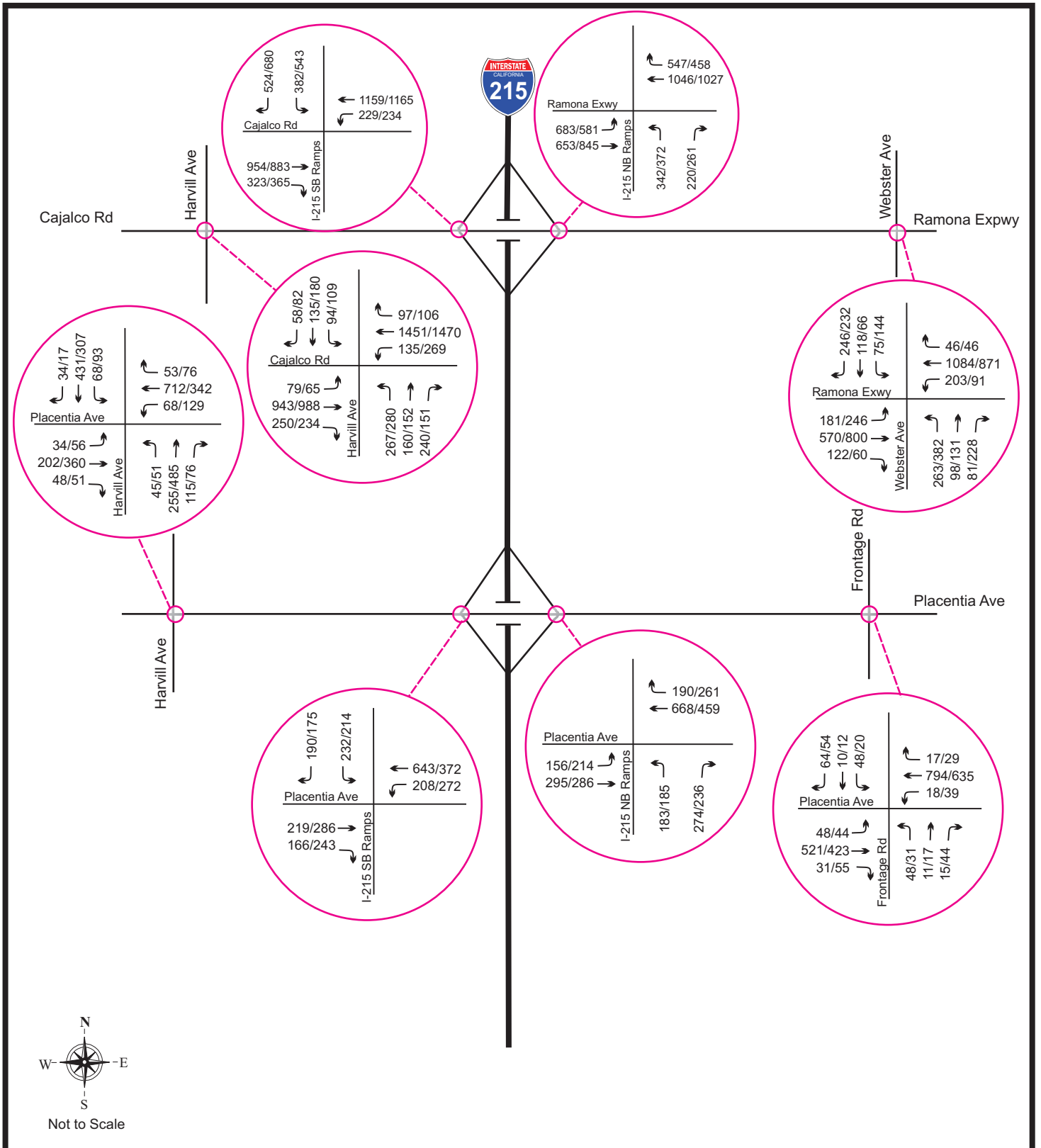

Horizon Year (2020) AM/PM Peak Hour Traffic Intersections - Build

Figure 6-18h

XXX/XXX AM/PM Peak Hour



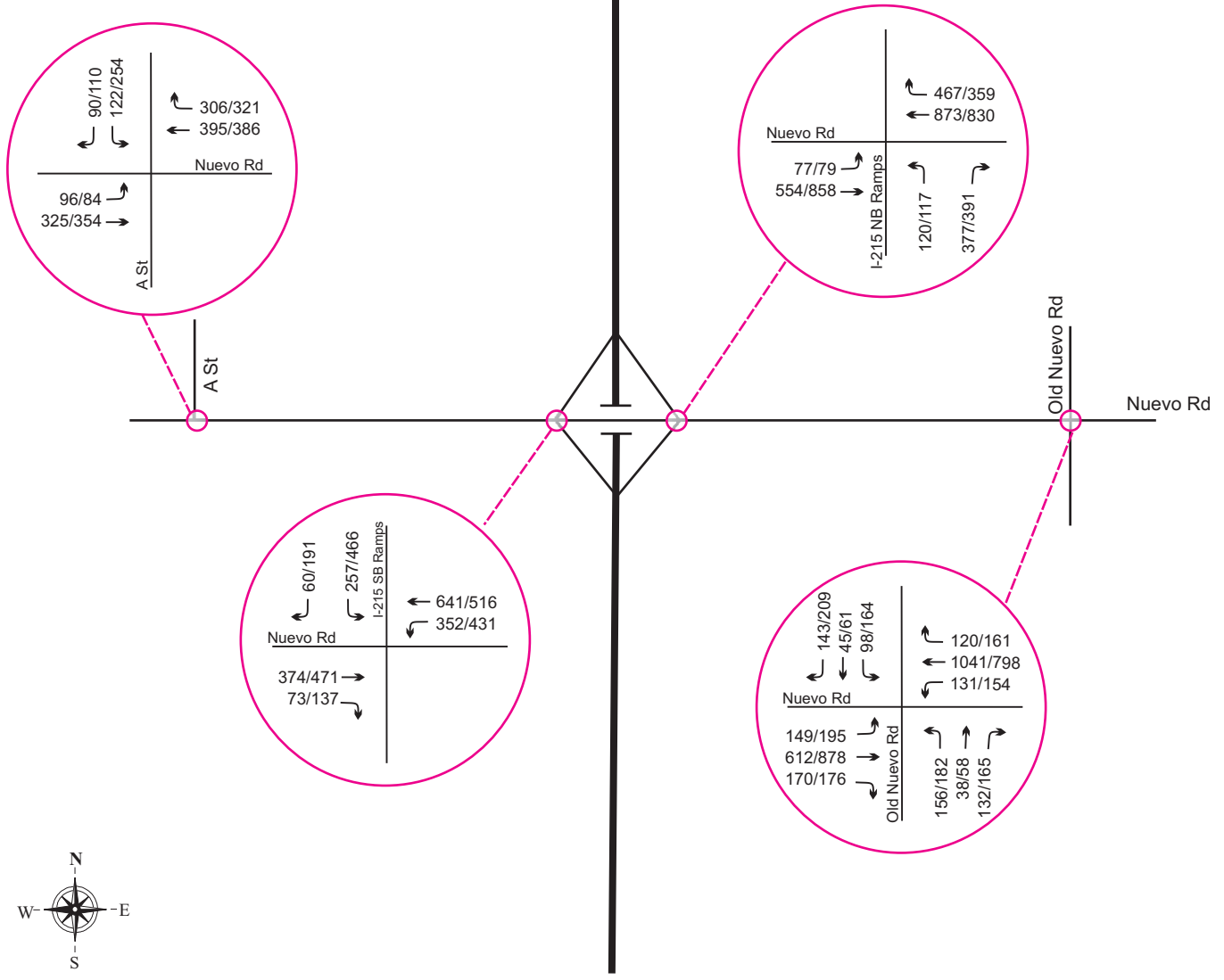

Horizon Year (2020) AM/PM Peak Hour Traffic Intersections - Build

Figure 6-18i

XXX/XXX AM/PM Peak Hour



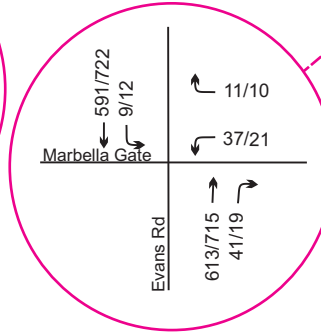
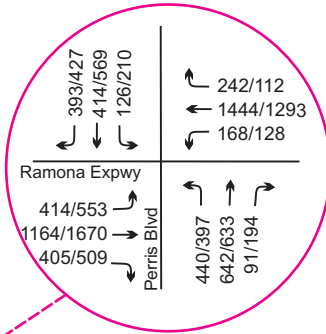
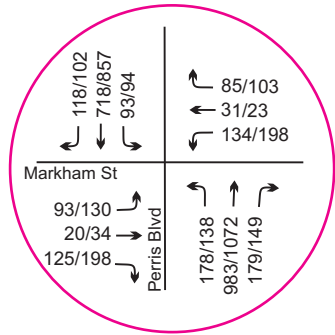

Ramona Expwy

Ramona Expwy

Evans Road

Marbella Gate

I-215/
Ramona/
Cajalco
Interchange

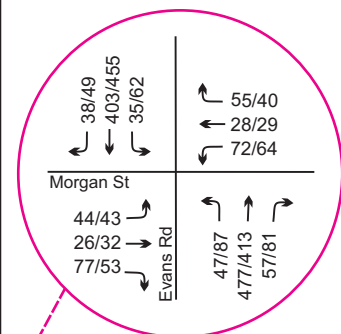
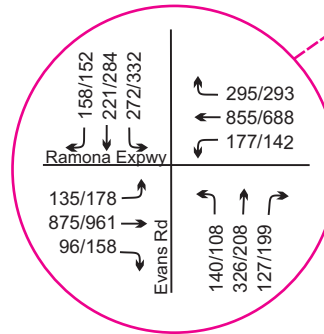
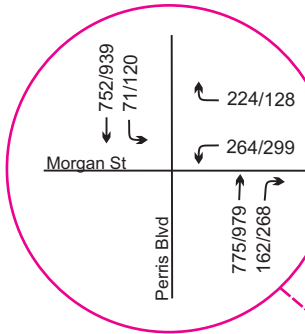

Perris Blvd

Morgan St

Morgan St



Not to Scale

Horizon Year (2020) AM/PM Peak Hour Traffic Intersections Build

Figure 6-18j

XXX/XXX AM/PM Peak Hour



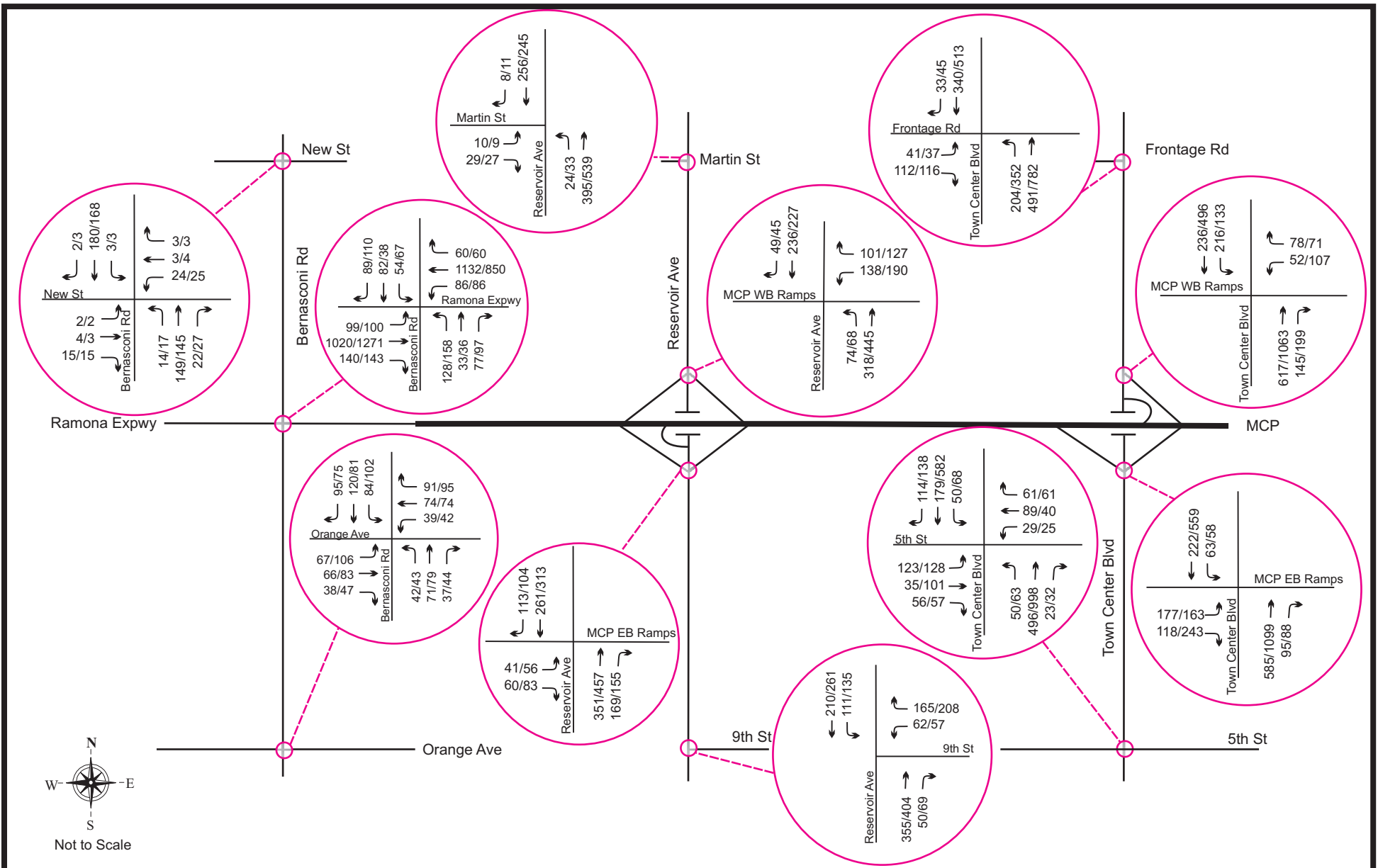

**Horizon Year (2020) AM/PM Peak Hour Traffic Intersections
Build**

Figure 6-18k

XXX/XXX AM/PM Peak Hour



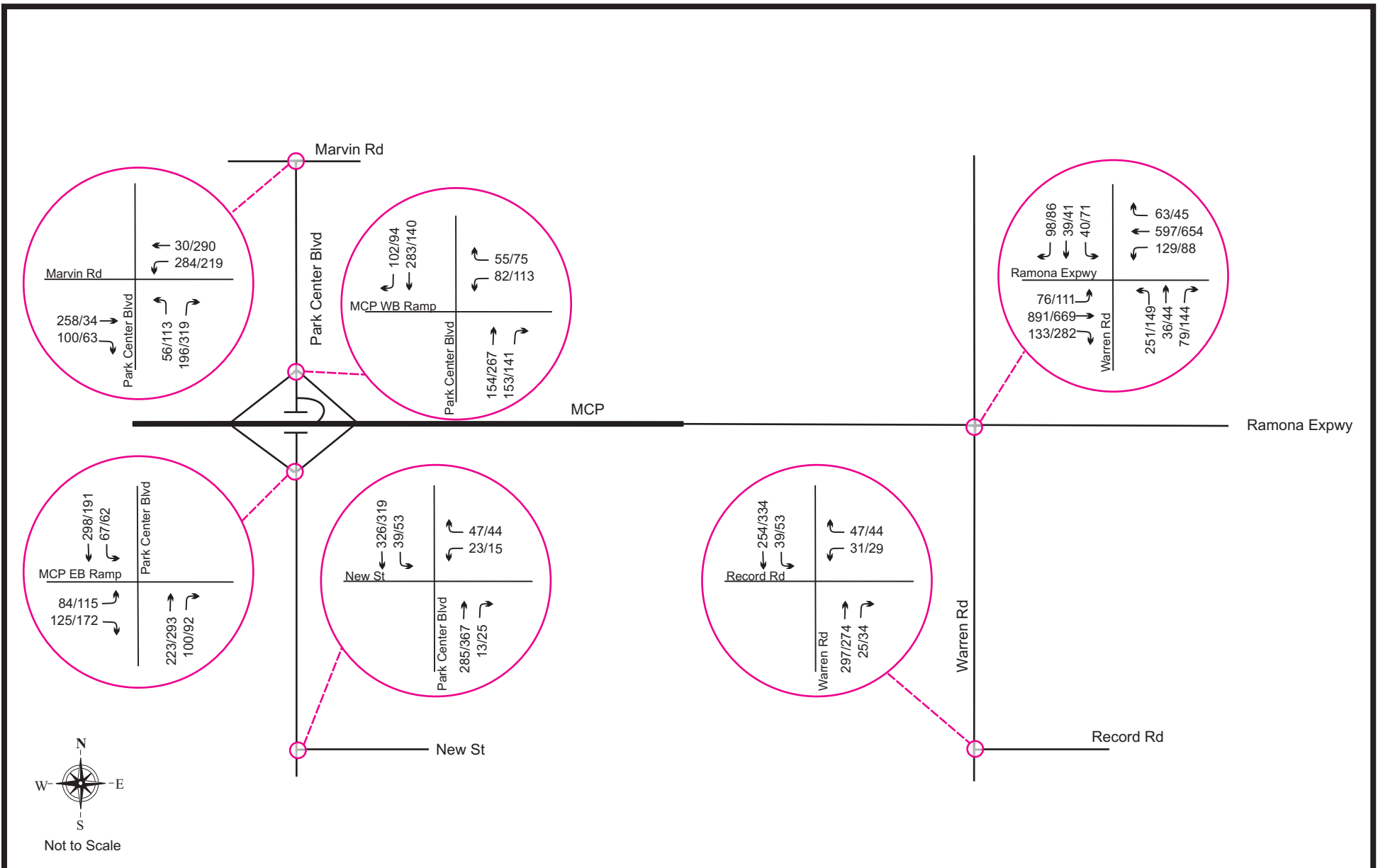

**Horizon Year (2020) AM/PM Peak Hour Traffic Intersections
Build**

Figure 6-18I

XXX/XXX AM/PM Peak Hour



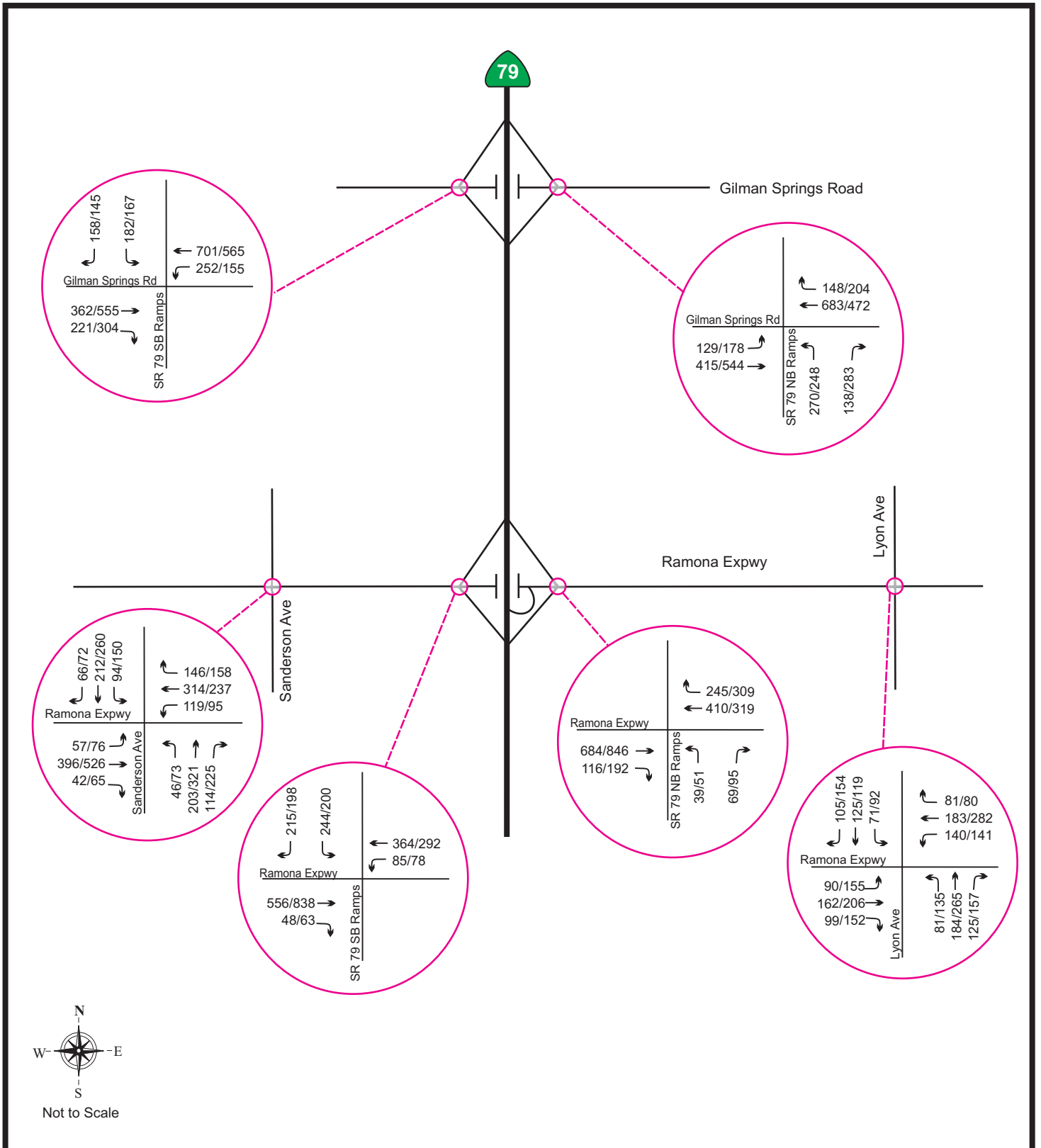

Horizon Year (2020) AM/PM Peak Hour Traffic Intersections - Build

Figure 6-18m

XXX/XXX AM/PM Peak Hour



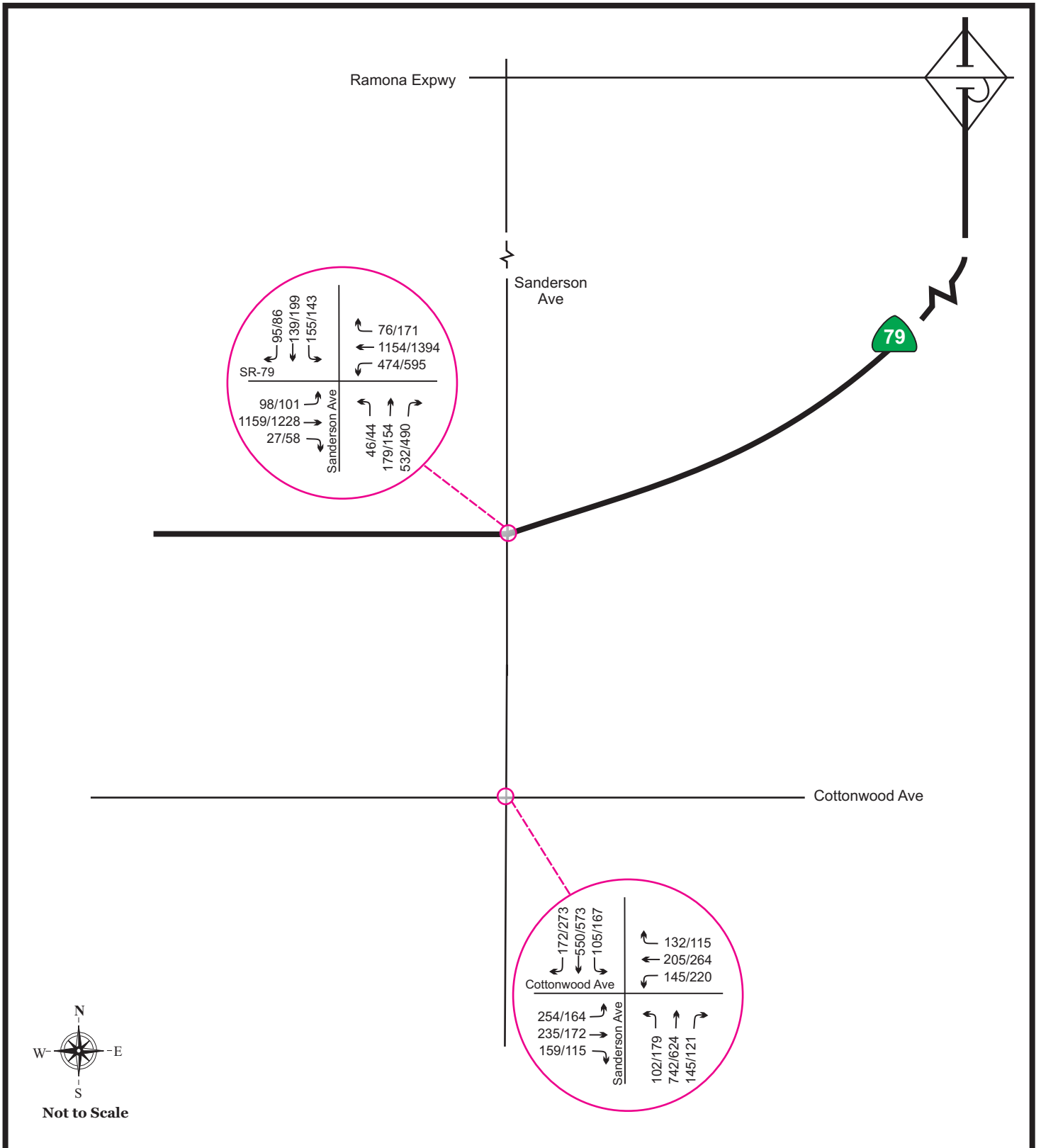

Horizon Year (2020) AM/PM Peak Hour Traffic Intersections - Build

Figure 6-18n

XXX/XXX AM/PM Peak Hour



Table 6-1
Horizon Year (2020)
Freeway and HOV Lane Capacity Analysis (1)
Interstate 15 - No Build

Northbound		Peak Hour Traffic (veh/hr)				Number of Lanes		Freeway Mainline and HOV Level of Service (2)				
		AM		PM				Freeway Capacity (3)	AM Peak Hour		PM Peak Hour	
Location	Facility	Freeway	HOV	Freeway	HOV	Freeway	HOV		LOS (4)	Density (5)	LOS (4)	Density (5)
I- 15 Mainline												
South of Temescal Canyon Rd	Freeway	6142		5654		4		8690	C	25.4	C	23.3
South of Temescal Canyon Rd	HOV		2816		2592		2		C	24.3	C	22.3
Temescal Canyon Rd On Ramp to Weirick Rd Off Ramp	Freeway	6562		6043		4		8690	D	27.5	C	25.0
Temescal Canyon Rd On Ramp to Weirick Rd Off Ramp	HOV		2816		2592		2		C	24.3	C	22.3
Weirick Rd On Ramp to Cajalco Rd Off Ramp	Freeway	6882		6334		4		8690	D	29.2	D	26.3
Weirick Rd On Ramp to Cajalco Rd Off Ramp	HOV		2816		2592		2		C	24.3	C	22.3
Cajalco Rd On Ramp to El Cerrito Rd Off Ramp	Freeway	7076		6513		4		8690	D	30.3	D	27.2
Cajalco Rd On Ramp to El Cerrito Rd Off Ramp	HOV		2816		2592		2		C	24.3	C	22.3
El Cerrito Rd On Ramp to Ontario Ave Off Ramp	Freeway	7014		6451		4		8690	D	30.0	D	26.9
El Cerrito Rd On Ramp to Ontario Ave Off Ramp	HOV		2992		2754		2		C	25.8	C	23.7
Ontario Ave On Ramp to Magnolia Ave Off Ramp	Freeway	6777		6238		4		8690	D	28.6	D	25.9
Ontario Ave On Ramp to Magnolia Ave Off Ramp	HOV		2992		2754		2		C	25.8	C	23.7
North of Magnolia Ave to SR-91	Freeway	7375		6678		4		8690	D	32.3	D	28.1
North of Magnolia Ave to SR-91	HOV		2992		2754		2		C	25.8	C	23.7

(1) Capacity Analysis shown for freeway mainline and HOV lanes. See separate page of Table 6-1 for ramps.

(2) One-lane HOV Lane density and level of service calculated using conditions for two freeway lanes and doubling the peak hour traffic.

(3) Freeway capacity is defined as the capacity at level of service E, expressed in vehicles per hour.

(4) LOS = Level of Service.

(5) Density is expressed in passenger cars/mile/lane. For facilities at level of service F, the density shown is the theoretical density that would occur if all demand could be accommodated.

Table 6-1 (cont.)
Horizon Year (2020)
Ramp Capacity Analysis (1)
Interstate 15 - No Build

Northbound		Peak Hour Traffic (veh/hr)				Number of Lanes		Ramp Level of Service			
		AM		PM				AM Peak Hour		PM Peak Hour	
Location	Facility	Freeway	Ramp	Freeway	Ramp	Freeway	Ramp	LOS (2)	Density (3)	LOS (2)	Density (3)
I - 15 Mainline											
Temescal Canyon Rd Off Ramp	Diverge	6142	210	5654	194	4	1	C	25.9	C	23.8
Temescal Canyon Rd On Ramp	Merge	5932	633	5460	583	4	1	C	22.6	C	20.8
Weirick Rd Off Ramp	Diverge	6562	541	6043	499	4	1	D	29.3	C	27.0
Weirick Rd On Ramp	Merge	6024	858	5544	790	4	1	C	22.5	C	21.3
Cajalco Rd Off Ramp	Diverge	6882	723	6334	666	4	1	D	31.6	D	29.1
Cajalco Rd EB On Ramp	Merge	6159	370	5668	340	4	1	C	22.3	C	20.9
Cajalco Rd WB On Ramp	Merge	6529	547	6008	505	4	1	C	23.5	C	22.1
El Cerrito Rd Off Ramp	Diverge	7076	546	6513	426	4	1	D	31.5	D	28.5
El Cerrito Rd On Ramp	Merge	6530	660	6087	531	4	1	C	23.5	C	22.3
Ontario Ave Off Ramp	Diverge	7014	889	6451	818	4	1	D	33.0	D	30.3
Ontario Ave On Ramp	Merge	6125	652	5633	605	4	1	C	22.5	C	21.3
Magnolia Ave Off Ramp	Diverge	6777	1121	6238	916	4	1	D	33.3	D	30.0
Magnolia Ave EB On Ramp	Merge	5656	1140	5322	901	4	1	C	22.1	C	21.0
Magnolia Ave WB On Ramp	Merge	6796	579	6223	455	4	1	C	24.1	C	22.6

(1) Capacity analysis shown for ramps only. See separate page of Table 7-2 for freeway mainline and HOV lanes.

(2) LOS = Level of Service.

(3) Density is expressed in passenger cars/mile/lane. For facilities at level of service F, the density shown is the theoretical density that would occur if all demand could be accommodated based on capacity of the adjacent freeway segment.

Table 6-1 (cont.)
 Horizon Year (2020)
 Freeway and HOV Lane Capacity Analysis (1)
 Interstate 15 - No Build

Southbound		Peak Hour Traffic (veh/hr)				Number of Lanes		Freeway Capacity (3)	Freeway Mainline and HOV Level of Service (2)			
		AM		PM					AM Peak Hour		PM Peak Hour	
Location	Facility	Freeway	HOV	Freeway	HOV	Freeway	HOV	LOS (4)	Density (5)	LOS (4)	Density (5)	
I-15 Mainline												
SR-91 to Magnolia Ave	Freeway	6819		8047		4		8690	D	28.8	E	37.6
SR-91 to Magnolia Ave	HOV		2448		3366		2		C	21.1	D	29.5
Magnolia Ave On Ramp to Ontario Ave Off Ramp	Freeway	5548		7619		4		8690	C	22.8	D	34.0
Magnolia Ave On Ramp to Ontario Ave Off Ramp	HOV		2448		3366		2		C	21.1	D	29.5
Ontario Ave On Ramp to El Cerrito Rd Off Ramp	Freeway	5887		8085		4		8690	C	24.3	E	38.0
Ontario Ave On Ramp to El Cerrito Rd Off Ramp	HOV		2448		3366		2		C	21.1	D	29.5
El Cerrito Rd On Ramp to Cajalco Rd Off Ramp	Freeway	5793		7956		4		8690	C	23.9	E	36.8
El Cerrito Rd On Ramp to Cajalco Rd Off Ramp	HOV		2304		3168		2		C	19.9	D	27.5
Cajalco Rd On Ramp to Weirick Rd Off Ramp	Freeway	5630		7742		4		8690	C	26.4	D	35.0
Cajalco Rd On Ramp to Weirick Rd Off Ramp	HOV		2304		3168		2		C	19.9	D	27.5
Weirick Rd On Ramp to Temescal Canyon Rd Off Ramp	Freeway	5371		7385		4		8690	C	22.1	D	32.3
Weirick Rd On Ramp to Temescal Canyon Rd Off Ramp	HOV		2304		3168		2		C	19.9	D	27.5
South of Temescal Canyon Rd	Freeway	5026		6910		4		8690	C	20.7	D	29.4
South of Temescal Canyon Rd	HOV		2304		3168		2		C	19.9	D	27.5

(1) Capacity Analysis shown for freeway mainline and HOV lanes. See separate page of Table 6-1 for ramps.

(2) One-lane HOV Lane density and level of service calculated using conditions for two freeway lanes and doubling the peak hour traffic.

(3) Freeway capacity is defined as the capacity at level of service E, expressed in vehicles per hour.

(4) LOS = Level of Service.

(5) Density is expressed in passenger cars/mile/lane. For facilities at level of service F, the density shown is the theoretical density that would occur if all demand could be accommodated.

Table 6-1 (cont.)
Horizon Year (2020)
Ramp Capacity Analysis (1)
Interstate 15 - No Build

Southbound		Peak Hour Traffic (veh/hr)				Number of Lanes		AM Peak Hour		PM Peak Hour	
		AM		PM							
Location	Facility	Freeway	Ramp	Freeway	Ramp	Freeway	Ramp	LOS (2)	Density (3)	LOS (2)	Density (3)
I - 15 Mainline											
Magnolia Ave Off Ramp	Diverge	6819	2084	8047	1546	4	1	F	45.0	F	45.0
Magnolia Ave On Ramp	Merge	4735	813	6501	1118	4	1	B	19.5	C	23.7
Ontario Ave Off Ramp	Diverge	5548	532	7619	732	4	1	C	25.2	D	34.6
Ontario Ave On Ramp	Merge	5016	727	6887	1000	4	1	B	20.0	C	24.4
El Cerrito Rd Off Ramp	Diverge	5887	472	8085	650	4	1	C	26.2	E	36.1
El Cerrito Rd On Ramp	Merge	5418	378	7435	521	4	1	C	20.3	C	25.8
Cajalco Rd Off Ramp	Diverge	5793	759	7956	1034	4	1	C	19.7	F	45.0
Cajalco Rd On Ramp	Merge	5034	596	6922	820	4	1	B	23.2	C	24.5
Weirick Rd Off Ramp	Diverge	5630	702	7742	966	4	1	C	26.4	E	36.4
Weirick Rd On Ramp	Merge	4928	443	6776	609	4	1	B	19.2	C	24.1
Temescal Canyon Rd Off Ramp	Diverge	5371	519	7385	713	4	1	C	24.4	D	33.6
Temescal Canyon Rd On Ramp	Merge	4852	174	6672	238	4	1	B	18.3	C	23.7

(1) Capacity analysis shown for ramps only. See separate page of Table 7-2 for freeway mainline and HOV lanes.

(2) LOS = Level of Service.

(3) Density is expressed in passenger cars/mile/lane. For facilities at level of service F, the density shown is the theoretical density that would occur if all demand could be accommodated based on capacity of the adjacent freeway segment.

Table 6-2
Opening Year (2020)
Freeway and HOV Lane Capacity Analysis (1)
Interstate 215 - No Build

Northbound		Peak Hour Traffic (veh/hr)				Number of Lanes		Freeway Mainline and HOV Lane Level of Service (2)				
		AM		PM				Freeway Capacity (3)	AM Peak Hour		PM Peak Hour	
Location	Facility	Freeway	HOV	Freeway	HOV	Freeway	HOV		LOS (4)	Density (5)	LOS (4)	Density (5)
I - 215 Mainline												
Nuevo Rd On Ramp to Cajalco/Ramona Expwy Off Ramp	Freeway	6754		6169		3		6470	F	47.0	E	40.1
Nuevo Rd On Ramp to Cajalco/Ramona Expwy Off Ramp	HOV		1800		1800		1	6470	D	32.2	D	32.2
Cajalco/Ramona Expwy On Ramp to Harley Knox Blvd Off Ramp	Freeway	7447		6564		3		6470	F	51.8	F	45.7
Cajalco/Ramona Expwy On Ramp to Harley Knox Blvd Off Ramp	HOV		1800		1800		1	6470	D	32.2	D	32.2
Harley Knox Blvd On Ramp to Van Buren Blvd Off Ramp	Freeway	7593		6869		3		6470	F	52.8	F	47.8
Harley Knox Blvd On Ramp to Van Buren Blvd Off Ramp	HOV		1800		1800		1	6470	D	32.2	D	32.2
Van Buren Blvd On Ramp to Cactus Ave Off Ramp	Freeway	7477		6837		3		6470	F	52.0	F	47.6
Van Buren Blvd On Ramp to Cactus Ave Off Ramp	HOV		1800		1800		1	6470	D	32.2	D	32.2
Cactus Ave On Ramp to Alessandro Blvd Off Ramp	Freeway	7024		6813		3		6470	F	48.9	F	47.4
Cactus Ave On Ramp to Alessandro Blvd Off Ramp	HOV		1800		1800		1	6470	D	32.2	D	32.2
North of Alessandro Blvd	Freeway	6694		6593		3		6470	F	46.6	F	45.9
North of Alessandro Blvd	HOV		1800		1800		1	6470	D	32.2	D	32.2

(1) Capacity Analysis shown for freeway mainline and HOV lanes. See separate page of Table 6-2 for ramps.

(2) One-lane HOV Lane density and level of service calculated using conditions for two freeway lanes and doubling the peak hour traffic.

(3) Freeway capacity is defined as the capacity at level of service E, expressed in vehicles per hour.

Table 6-2 (cont.)
Opening Year (2020)
Ramp Capacity Analysis (1)
Interstate 215 - No Build

Northbound		Peak Hour Traffic (veh/hr)				Number of Lanes		Ramp Level of Service			
		AM		PM				AM Peak Hour		PM Peak Hour	
Location	Facility	Freeway	Ramp	Freeway	Ramp	Freeway	Ramp	LOS (2)	Density (3)	LOS (2)	Density (3)
I - 215 Mainline											
D Street On Ramp to Nuevo Rd Off Ramp	Weave (4)	6817		6317		4		D	31.7	D	29.3
Nuevo Rd Off Ramp	Diverge (5)	6817	678	6317	697	4	2	B	12.0	B	10.9
Nuevo Rd On Ramp	Merge	6133	621	5620	549	3	1	F	47.0	D	34.9
Cajalco/Ramona Expwy Off Ramp	Diverge	6754	659	6169	721	3	1	F	47.0	D	32.8
Cajalco/Ramona Expwy On Ramp	Merge	6095	1352	5458	1106	3	1	F	51.8	F	45.7
Harley Knox Blvd Off Ramp	Diverge	7447	436	6564	460	3	1	F	51.8	E	35.9
Harley Knox Blvd On Ramp	Merge	7011	582	6094	775	3	1	F	52.8	F	47.8
Van Buren Blvd Off Ramp	Diverge	7593	865	6869	724	3	2	F	52.8	F	47.8
Van Buren Blvd EB On Ramp	Merge	6728	609	6145	530	3	1	F	52.0	F	47.6
Van Buren Blvd WB On Ramp	Merge	7337	140	6675	162	3	1	F	52.0	F	47.6
Cactus Ave Off Ramp	Diverge	7477	884	6837	684	3	1	F	52.0	F	47.6
Cactus Ave EB On Ramp	Merge	6593	167	6153	245	3	1	F	48.9	E	35.1
Cactus Ave WB On Ramp	Merge	6760	264	6398	415	3	1	F	48.9	F	47.4
Alessandro Blvd Off Ramp	Diverge	7024	915	6813	905	3	1	F	48.9	F	47.4
Alessandro Blvd On Ramp	Merge	6109	585	5908	685	3	1	F	46.6	E	37.4

(1) Capacity analysis shown for ramps only. See separate page of Table 6-2 for freeway mainline and HOV lanes.

Table 6-2 (cont.)
Opening Year (2020)
Freeway and HOV Lane Capacity Analysis (1)
Interstate 215 - No Build

Southbound		Peak Hour Traffic (veh/hr)				Number of Lanes		Freeway Mainline and HOV Lane Level of Service (2)				
		AM		PM				Freeway Capacity (3)	AM Peak Hour		PM Peak Hour	
Location	Facility	Freeway	Ramp	Freeway	Ramp	Freeway	Ramp		LOS (4)	Density (5)	LOS (4)	Density (5)
I - 215 Mainline												
North of Alessandro Blvd	Freeway	6117		8017		3		6470	E	39.3	F	55.8
North of Alessandro Blvd	HOV		1800		1800		1	6470	D	32.2	D	32.2
Alessandro Blvd On Ramp to Cactus Ave Off Ramp	Freeway	6226		8218		3		6470	E	40.9	F	57.2
Alessandro Blvd On Ramp to Cactus Ave Off Ramp	HOV		1800		1800		1	6470	D	32.2	D	32.2
Cactus Ave On Ramp to Van Buren Blvd Off Ramp	Freeway	6391		8448		3		6470	E	43.5	F	58.8
Cactus Ave On Ramp to Van Buren Blvd Off Ramp	HOV		1800		1800		1	6470	D	32.2	D	32.2
Van Buren Blvd On Ramp to Harley Knox Blvd Off Ramp	Freeway	6358		8555		3		6470	E	36.1	F	59.5
Van Buren Blvd On Ramp to Harley Knox Blvd Off Ramp	HOV		1800		1800		1	6470	D	32.2	D	32.2
Harley Knox Blvd On Ramp to Cajalco/Ramona Expwy Off Ramp	Freeway	5993		8369		3		6470	E	37.7	F	58.2
Harley Knox Blvd On Ramp to Cajalco/Ramona Expwy Off Ramp	HOV		1800		1800		1	6470	D	32.2	D	32.2
Cajalco/Ramona Expwy On Ramp to Nuevo Rd Off Ramp	Freeway	5537		7813		3		6470	D	32.9	F	54.3
Cajalco/Ramona Expwy On Ramp to Nuevo Rd Off Ramp	HOV		1800		1800		1	6470	D	32.2	D	32.2
Nuevo Rd On Ramp to D Street Off Ramp	HOV		1800		1800		1	6470	D	32.2	D	32.2

(1) Capacity Analysis shown for freeway mainline and HOV lanes. See separate page of Table 6-2 for ramps.

(2) One-lane HOV Lane density and level of service calculated using conditions for two freeway lanes and doubling the peak hour traffic.

(3) Freeway capacity is defined as the capacity at level of service E, expressed in vehicles per hour.

(4) LOS = Level of Service.

(5) Density is expressed in passenger cars/mile/lane. For facilities at level of service F, the density shown is the theoretical density that would occur if all demand could be accommodated.

Table 6-2 (cont.)
Opening Year (2020)
Freeway and Ramp Capacity Analysis (1)
Interstate 215 - No Build

Southbound		Peak Hour Traffic (veh/hr)				Number of Lanes		Ramp Level of Service			
		AM		PM				AM Peak Hour		PM Peak Hour	
Location	Facility	Freeway	Ramp	Freeway	Ramp	Freeway	Ramp	LOS (2)	Density (3)	LOS (2)	Density (3)
I - 215 Mainline											
Alessandro Blvd Off Ramp	Diverge	6117	593	8017	686	3	1	D	34.4	F	55.8
Alessandro Blvd WB On Ramp	Merge	5524	220	7331	299	3	1	D	31.8	F	57.2
Alessandro Blvd EB On Ramp	Merge	5744	482	7630	588	3	1	D	35.0	F	57.2
Cactus Ave WB Off Ramp	Diverge	6226	338	8218	309	3	1	D	34.5	F	57.2
Cactus Ave EB Off Ramp	Diverge	5888	218	7909	188	3	1	D	33.0	F	57.2
Cactus Ave On Ramp	Merge	5670	721	7611	837	3	1	E	36.5	F	58.8
Van Buren Blvd Off Ramp	Diverge	6391	621	8448	727	3	1	E	35.5	F	58.8
Van Buren Blvd On Ramp	Merge	5770	588	7721	834	3	1	E	36.0	F	59.5
Harley Knox Blvd Off Ramp	Diverge	6358	673	8555	645	3	1	E	35.5	F	59.5
Harley Knox Blvd On Ramp	Merge	5685	308	7910	459	3	1	D	33.3	F	58.2
Cajalco/Ramona Expwy Off Ramp	Diverge	5993	1097	8369	1346	3	1	D	34.8	F	58.2
Cajalco/Ramona Expwy On Ramp	Merge	4896	641	7023	790	3	1	D	32.0	F	54.3
Nuevo Rd Off Ramp	Diverge	5537	488	7813	864	3	1	D	31.9	F	54.3
Nuevo Rd On Ramp	Merge (4)	5049	531	6949	717	3	1	D	31.9	F	45.0
Nuevo Rd On Ramp to D Street Off Ramp	Weave (5)	5580		7666		4		D	27.6	E	41.3

(1) Capacity analysis shown for ramps only. See separate page of Table 6-2 for freeway mainline and HOV lanes.

(2) LOS = Level of Service.

(3) Density is expressed in passenger cars/mile/lane. For facilities at level of service F, the density shown is the theoretical density that would occur if all demand could be accommodated based on capacity of the adjacent freeway segment.

(4) Ramp capacity analysis shown for information only, since this is technically part of a weaving section.

(5) For weaving volumes, see Figure 6-7c. The ramp to ramp movement was assumed to be zero. Weaving length is 2,000 feet per the I-215 widening project.

Table 6-3
Horizon Year (2020)
Intersection Capacity Analysis - No Build
I-15 Area

Intersection	AM Peak Hour		PM Peak Hour	
	LOS	Average Delay (sec)	LOS	Average Delay (sec)
Magnolia Avenue and El Sobrante Road	F	>80.0	F	>80.0
Magnolia Avenue and I-15 Southbound Ramps	F	>80.0	F	>80.0
Magnolia Avenue and I-15 Northbound Ramps	C	21.7	B	17.1
Magnolia Avenue and El Camino Avenue	B	14.3	C	23.4
Ontario Avenue and California Avenue	C	27.9	D	48.3
Ontario Avenue and I-15 Southbound Ramps	B	10.8	B	15.2
Ontario Avenue and I-15 Northbound Ramps	C	31.0	C	28.7
Ontario Avenue and State Street	B	12.9	B	11.0
El Cerrito Road and Bedford Canyon Road	B	15.7	B	18.7
El Cerrito Road and I-15 Southbound Ramps	B	13.1	B	13.9
El Cerrito Road and I-15 Northbound Ramps	C	29.9	C	27.6
El Cerrito Road and Temescal Canyon Road	C	25.1	B	18.8
Cajalco Road and Bedford Canyon Road	B	17.1	C	26.0
Cajalco Road and I-15 Southbound Ramps	C	24.0	C	23.4
Cajalco Road and I-15 Northbound Ramps	B	12.1	B	11.6
Cajalco Road and Temescal Canyon Road	C	29.2	D	38.0
Weirick Road and Knabe Road	C	28.3	C	28.4
Weirick Road and I-15 Southbound Ramps	C	21.5	C	23.3
Weirick Road and I-15 Northbound Ramps	B	10.7	A	9.8
Weirick Road and Temescal Canyon Road	C	23.7	C	27.4
Temescal Canyon Road and Lawson Drive	A	8.6	A	7.7
Temescal Canyon Road and I-15 Southbound Ramps	B	15.4	C	23.7
Temescal Canyon Road and I-15 Northbound Ramps	C	23.3	C	25.1

Notes:

">80" – Exceeds 80 seconds

Table 6-3 (cont.)
 Horizon Year (2020)
 Intersection Capacity Analysis - No Build
 Cajalco Road, I-15 to I-215

Intersection	AM Peak Hour		PM Peak Hour	
	LOS	Average Delay (sec)	LOS	Average Delay (sec)
Eagle Valley Road and Cajalco Road	B	10.8	B	11.6
Lake Matthews Road and Cajalco Road	B	11.8	B	15.8
El Sobrante Road and Calalco Road	B	11.4	B	15.6
Wood Road and Cajalco Road	C	29.3	C	27.8
Alexander Street and Cajalco Road	B	17.3	B	13.4
Clark Street and Cajalco Road	B	17.4	B	19.9

Notes:

">80" – Exceeds 80 seconds

Table 6-3 (cont.)
Horizon Year (2020)
Intersection Capacity Analysis - No Build
I-215 Area

Intersection	AM Peak Hour		PM Peak Hour	
	LOS	Average Delay (sec)	LOS	Average Delay (sec)
Alessandro Blvd and Meridian Parkway	D	45.8	F	>80.0
Alessandro Blvd and I-215 Southbound Ramps	D	43.9	D	46.8
Alessandro Blvd and I-215 Northbound Ramps	C	23.9	D	48.0
Alessandro Blvd and Valley Springs Parkway	C	25.1	E	77.4
Cactus Avenue and Innovation Drive	B	16.8	B	18.5
Cactus Avenue and I-215 Southbound Ramps	B	18.1	B	11.3
Cactus Avenue and I-215 Northbound Ramps	C	24.3	C	20.9
Cactus Avenue and Ellsworth Street	D	47.4	C	31.6
Van Buren Boulevard and Meridian Parkway	C	28.0	C	22.0
Van Buren Boulevard and I-215 Southbound Ramps	B	10.4	B	13.0
Van Buren Boulevard and I-215 Northbound Ramps	B	18.4	B	17.5
Harley Knox Blvd and Harvill Avenue	B	14.9	B	17.2
Harley Knox Blvd and I-215 Southbound Ramps	C	26.0	C	27.2
Harley Knox Blvd and I-215 Northbound Ramps	B	16.4	C	21.2
Harley Knox Blvd and Western Way	A	6.3	A	6.7
Cajalco Road and Harvill Avenue	C	21.4	C	27.0
Cajalco Road and I-215 Southbound Ramps	C	33.1	D	38.2
Cajalco Road and I-215 Northbound Ramps	D	40.1	C	26.9
Ramona Expressway and Webster Avenue	D	45.7	D	38.0
Placentia Avenue and Harvill Avenue	C	33.5	D	37.9
Placentia Avenue and East Frontage Road	B	13.9	B	11.0
Nuevo Road and A Street	B	14.4	C	20.2
Nuevo Road and I-215 Southbound Ramps	C	29.0	E	63.6
Nuevo Road and I-215 Northbound Ramps	B	16.4	C	25.3
Nuevo Road and Old Nuevo Road	C	29.4	D	38.9

Notes:

">80" – Exceeds 80 seconds

Table 6-3 (cont.)
Horizon Year (2020)
No Build
Intersection Capacity Analysis
Ramona Expressway, I-215 to SR 79

Intersection	AM Peak Hour		PM Peak Hour	
	LOS	Average Delay (sec)	LOS	Average Delay (sec)
Perris Boulevard and Markham Street	C	32.9	D	49.4
Perris Boulevard and Ramona Expressway	E	60.7	E	64.1
Perris Boulevard and Morgan Street	B	15.7	B	19.5
Evans Road and Marbella Gate	A	2.9	A	2.4
Evans Road and Ramona Expressway	C	34.8	C	32.4
Evans Road and Morgan Street	A	9.4	A	8.7
Bernasconi Road and New Street	B	10.4	B	11.0
Bernasconi Road and Ramona Expressway	C	25.2	C	24.7
Bernasconi Road and Orange Avenue	C	30.1	C	33.8
Reservoir Avenue and Martin St	B	18.7	B	19.6
Reservoir Avenue and Ramona Expressway	C	33.1	D	38.8
Reservoir Avenue and 9th Street	B	15.9	B	15.2
Town Center Boulevard and Frontage Rd	B	11.5	A	10.0
Town Center Boulevard and Ramona Expressway	D	38.5	D	36.9
Town Center Boulevard and 5th Street	C	23.0	C	22.1
Park Center Boulevard and Marvin Road	D	35.3	C	29.6
Park Center Boulevard and Ramona Expressway	D	36.1	C	33.8
Park Center Boulevard and New Street	A	6.7	A	7.2
Warren Road and Ramona Expressway	D	38.3	C	30.8
Warren Road and Record Road	A	8.3	A	9.0
Gilman Springs Road and SR 79 Southbound Ramps	B	17.3	B	15.7
Gilman Springs Road and SR 79 Northbound Ramps	C	20.2	B	19.4
Ramona Expressway and SR 79 Southbound Ramps	B	18.5	B	17.5
Ramona Expressway and SR 79 Southbound Ramps	C	21.4	B	18.7
Ramona Expressway and Lyon Avenue	C	22.9	C	26.1
Sanderson Avenue and SR 79	D	49.2	D	45.3
Sanderson Avenue and Ramona Expressway	C	24.0	C	25.6
Sanderson Avenue and Cottonwood Avenue	C	29.8	C	31.4

Notes:

">80" – Exceeds 80 seconds

Table 6-4
Horizon Year (2020)
Freeway and HOV Lane Capacity Analysis (1)
Interstate 15 - Build

Northbound		Peak Hour Traffic (veh/hr)						Freeway Mainline and HOV Level of Service (2)				
		AM		PM		Number of Lanes		Freeway Capacity (3)	AM Peak Hour		PM Peak Hour	
		Freeway	HOV	Freeway	HOV	Freeway	HOV		LOS (4)	Density (5)	LOS (4)	Density (5)
Location	Facility											
I - 15 Mainline												
South of Temescal Canyon Rd	Freeway	6142		5654		4		8690	C	25.4	C	23.3
South of Temescal Canyon Rd	HOV		2816		2592		2		C	24.3	C	22.3
Temescal Canyon Rd On Ramp to Weirick Rd Off Ramp	Freeway	6565		6043		4		8690	D	27.5	C	25.0
Temescal Canyon Rd On Ramp to Weirick Rd Off Ramp	HOV		2816		2592		2		C	24.3	C	22.3
Weirick Rd On Ramp to Cajalco Rd Off Ramp	Freeway	6882		6334		4		8690	D	29.2	D	26.3
Weirick Rd On Ramp to Cajalco Rd Off Ramp	HOV		2816		2592		2		C	24.3	C	22.3
Cajalco Rd On Ramp to El Cerrito Rd Off Ramp	Freeway	7094		6529		4		8690	D	30.5	D	27.3
Cajalco Rd On Ramp to El Cerrito Rd Off Ramp	HOV		2816		2592		2		C	24.3	C	22.3
El Cerrito Rd On Ramp to Ontario Ave Off Ramp	Freeway	7032		6467		4		8690	D	30.1	D	27.0
El Cerrito Rd On Ramp to Ontario Ave Off Ramp	HOV		2992		2754		2		C	25.8	C	23.7
Ontario Ave On Ramp to Magnolia Ave Off Ramp	Freeway	6795		6254		4		8690	D	28.7	C	26.0
Ontario Ave On Ramp to Magnolia Ave Off Ramp	HOV		2992		2754		2		C	25.8	C	23.7
North of Magnolia Ave to SR-91	Freeway	7393		6694		4		8690	D	32.4	D	28.2
North of Magnolia Ave to SR-91	HOV		2992		2754		2		C	25.8	C	23.7

(1) Capacity Analysis shown for freeway mainline and HOV lanes. See separate page of Table 6-4 for ramps.

(2) One-lane HOV Lane density and level of service calculated using conditions for two freeway lanes and doubling the peak hour traffic.

(3) Freeway capacity is defined as the capacity at level of service E, expressed in vehicles per hour.

(4) LOS = Level of Service.

(5) Density is expressed in passenger cars/mile/lane. For facilities at level of service F, the density shown is the theoretical density that would occur if all demand could be accommodated.

Table 6-4
Horizon Year (2020)
Ramp Capacity Analysis (1)
Interstate 15 - Build

Northbound		Peak Hour Traffic (veh/hr)				Number of Lanes		Ramp Level of Service			
		AM		PM				AM Peak Hour		PM Peak Hour	
Location	Facility	Freeway	Ramp	Freeway	Ramp	Freeway	Ramp	LOS (2)	Density (3)	LOS (2)	Density (3)
I - 15 Mainline											
Temescal Canyon Rd Off Ramp	Diverge	6142	210	5654	194	4	1	C	25.9	C	23.8
Temescal Canyon Rd On Ramp	Merge	5932	633	5460	583	4	1	C	22.0	C	20.8
Weirick Rd Off Ramp	Diverge	6565	541	6043	499	4	1	D	29.3	C	27.0
Weirick Rd On Ramp	Merge	6024	858	5544	790	4	1	C	22.5	C	21.3
Cajalco Rd Off Ramp	Diverge	6882	723	6334	666	4	1	D	31.6	D	29.1
Cajalco Rd EB On Ramp	Merge	6159	370	5668	340	4	1	C	22.3	C	20.9
Cajalco Rd WB On Ramp	Merge	6529	565	6008	521	4	1	C	23.5	C	22.1
El Cerrito Rd Off Ramp	Diverge	7094	546	6529	426	4	1	D	31.5	D	28.6
El Cerrito Rd On Ramp	Merge	6548	660	6103	531	4	1	C	23.6	C	22.3
Ontario Ave Off Ramp	Diverge	7032	889	6467	818	4	1	D	33.1	D	30.4
Ontario Ave On Ramp	Merge	6143	652	5649	605	4	1	C	22.6	C	21.3
Magnolia Ave Off Ramp	Diverge	6795	1121	6254	916	4	1	D	33.3	D	30.0
Magnolia Ave EB On Ramp	Merge	5674	1140	5338	901	4	1	C	22.1	C	21.0
Magnolia Ave WB On Ramp	Merge	6814	579	6239	455	4	1	C	24.2	C	22.6

(1) Capacity analysis shown for ramps only. See separate page of Table 6-4 for freeway mainline and HOV lanes.

(2) LOS = Level of Service.

(3) Density is expressed in passenger cars/mile/lane. For facilities at level of service F, the density shown is the theoretical density that would occur if all demand could be accommodated based on capacity of the adjacent freeway segment.

Table 6-4 (cont.)
Horizon Year (2020)
Freeway and HOV Lane Capacity Analysis (1)
Interstate 15 - Build

Southbound		Peak Hour Traffic (veh/hr)				Number of Lanes		Freeway Capacity (3)	Freeway Mainline and HOV Level of Service (2)			
		AM		PM					AM Peak Hour		PM Peak Hour	
Location	Facility	Freeway	HOV	Freeway	HOV	Freeway	HOV	LOS (4)	Density (5)	LOS (4)	Density (5)	
I - 15 Mainline												
SR-91 to Magnolia Ave	Freeway	6835		8065		4		8690	D	28.9	E	37.8
SR-91 to Magnolia Ave	HOV		2448		3366		2		C	21.1	D	29.5
Magnolia Ave On Ramp to Ontario Ave Off Ramp	Freeway	5564		7637		4		8690	C	22.9	D	34.2
Magnolia Ave On Ramp to Ontario Ave Off Ramp	HOV		2448		3366		2		C	21.1	D	29.5
Ontario Ave On Ramp to El Cerrito Rd Off Ramp	Freeway	5903		8103		4		8690	C	24.4	E	38.2
Ontario Ave On Ramp to El Cerrito Rd Off Ramp	HOV		2448		3366		2		C	21.1	D	29.5
El Cerrito Rd On Ramp to Cajalco Rd Off Ramp	Freeway	5809		7974		4		8690	C	24.0	E	37.0
El Cerrito Rd On Ramp to Cajalco Rd Off Ramp	HOV		2304		3168		2		C	19.9	D	27.5
Cajalco Rd On Ramp to Weirick Rd Off Ramp	Freeway	5630		7742		4		8690	C	23.2	D	35.0
Cajalco Rd On Ramp to Weirick Rd Off Ramp	HOV		2304		3168		2		C	19.9	D	27.5
Weirick Rd On Ramp to Temescal Canyon Rd Off Ramp	Freeway	5371		7385		4		8690	C	22.1	D	32.3
Weirick Rd On Ramp to Temescal Canyon Rd Off Ramp	HOV		2304		3168		2		C	19.9	D	27.5
South of Temescal Canyon Rd	Freeway	5026		6910		4		8690	C	20.7	D	29.4
South of Temescal Canyon Rd	HOV		2304		3168		2		C	19.9	D	27.5

(1) Capacity Analysis shown for freeway mainline and HOV lanes. See separate page of Table 6-4 for ramps.

(2) One-lane HOV Lane density and level of service calculated using conditions for two freeway lanes and doubling the peak hour traffic.

(3) Freeway capacity is defined as the capacity at level of service E, expressed in vehicles per hour.

(4) LOS = Level of Service.

(5) Density is expressed in passenger cars/mile/lane. For facilities at level of service F, the density shown is the theoretical density that would occur if all demand could be accommodated.

Table 6-4 (cont.)
Horizon Year (2020)
Ramp Capacity Analysis (1)
Interstate 15 - Build

Southbound		Peak Hour Traffic (veh/hr)				Number of Lanes		Ramp Level of Service			
		AM		PM				AM Peak Hour		PM Peak Hour	
Location	Facility	Freeway	Ramp	Freeway	Ramp	Freeway	Ramp	LOS (2)	Density (3)	LOS (2)	Density (3)
I - 15 Mainline											
Magnolia Ave Off Ramp	Diverge	6835	2084	8065	1546	4	1	F	45.0	F	45.0
Magnolia Ave On Ramp	Merge	4751	813	6519	1118	4	1	B	19.6	C	23.7
Ontario Ave Off Ramp	Diverge	5564	532	7637	732	4	1	C	25.2	D	34.7
Ontario Ave On Ramp	Merge	5032	727	6905	1000	4	1	C	20.0	C	24.4
El Cerrito Rd Off Ramp	Diverge	5903	472	8103	650	4	1	C	26.3	E	36.2
El Cerrito Rd On Ramp	Merge	5431	378	7453	521	4	1	C	20.3	C	25.8
Cajalco Rd Off Ramp	Diverge	5809	775	7974	1052	4	1	C	27.5	F	45.0
Cajalco Rd On Ramp	Merge	5034	596	6922	820	4	1	B	19.7	C	24.5
Weirick Rd Off Ramp	Diverge	5630	702	7742	966	4	1	C	26.4	E	36.4
Weirick Rd On Ramp	Merge	4928	443	6776	609	4	1	B	19.1	C	24.1
Temescal Canyon Rd Off Ramp	Diverge	5371	519	7385	713	4	1	C	24.4	D	33.6
Temescal Canyon Rd On Ramp	Merge	4852	174	6672	238	4	1	B	18.3	C	23.7

(1) Capacity analysis shown for ramps only. See separate page of Table 6-4 for freeway mainline and HOV lanes.

(2) LOS = Level of Service.

(3) Density is expressed in passenger cars/mile/lane. For facilities at level of service F, the density shown is the theoretical density that would occur if all demand could be accommodated based on capacity of the adjacent freeway segment.

Table 6-5
Opening Year (2020)
Freeway and HOV Lane Capacity Analysis (1)
Interstate 215 - Build

Northbound		Peak Hour Traffic (veh/hr)				Number of Lanes		Freeway Mainline and HOV Lane Level of Service (2)					
		AM		PM				Freeway Capacity (3)	AM Peak Hour		PM Peak Hour		
		Location	Facility	Freeway	HOV	Freeway	HOV		Freeway	HOV	LOS (4)	Density (5)	LOS (4)
I - 215 Mainline													
Nuevo Rd On Ramp to Placentia Ave Off Ramp		Freeway	7104		6368		4		8690	D	30.5	D	26.5
Nuevo Rd On Ramp to Placentia Ave Off Ramp		HOV		1800		1800		1	8690	D	32.2	D	32.2
Placentia Ave On Ramp to Cajalco/Ramona Expwy Off Ramp		Freeway	6993		6422		4		8690	D	29.8	D	26.8
Placentia Ave On Ramp to Cajalco/Ramona Expwy Off Ramp		HOV		1800		1800		1	8690	D	32.2	D	32.2
Cajalco/Ramona Expwy On Ramp to Harley Knox Blvd Off Ramp		Freeway	7661		6828		4		8690	D	34.4	D	28.9
Cajalco/Ramona Expwy On Ramp to Harley Knox Blvd Off Ramp		HOV		1800		1800		1	8690	D	32.2	D	32.2
Harley Knox Blvd On Ramp to Van Buren Blvd Off Ramp		Freeway	7882		7263		4		8690	E	36.2	D	31.5
Harley Knox Blvd On Ramp to Van Buren Blvd Off Ramp		HOV		1800		1800		1	8690	D	32.2	D	32.2
Van Buren Blvd On Ramp to Cactus Ave Off Ramp		Freeway	7668		7103		3		6470	F	53.3	F	49.4
Van Buren Blvd On Ramp to Cactus Ave Off Ramp		HOV		1800		1800		1	6470	D	32.2	D	32.2
Cactus Ave On Ramp to Alessandro Blvd Off Ramp		Freeway	7196		6996		3		6470	F	50.0	F	48.7
Cactus Ave On Ramp to Alessandro Blvd Off Ramp		HOV		1800		1800		1	6470	D	32.2	D	32.2
North of Alessandro Blvd		Freeway	6786		6746		3		6470	F	47.2	F	46.9
North of Alessandro Blvd		HOV		1800		1800		1	6470	D	32.2	D	32.2

(1) Capacity Analysis shown for freeway mainline and HOV lanes. See separate page of Table 6-5 for ramps.

(2) One-lane HOV Lane density and level of service calculated using conditions for two freeway lanes and doubling the peak hour traffic.

(3) Freeway capacity is defined as the capacity at level of service E, expressed in vehicles per hour.

(4) LOS = Level of Service.

(5) Density is expressed in passenger cars/mile/lane. For facilities at level of service F, the density shown is the theoretical density that would occur if all demand could be accommodated.

Table 6-5 (cont.)
Opening Year (2020)
Ramp Capacity Analysis (1)
Interstate 215 - Build

Northbound		Peak Hour Traffic (veh/hr)				Number of Lanes		Ramp Level of Service			
		AM		PM				AM Peak Hour		PM Peak Hour	
Location	Facility	Freeway	Ramp	Freeway	Ramp	Freeway	Ramp	LOS (2)	Density (3)	LOS (2)	Density (3)
I - 215 Mainline											
D Street On Ramp to Nuevo Rd Off Ramp	Weave (4)	7057		6438		4		D	32.0	D	29.0
Nuevo Rd Off Ramp	Diverge (5)	7057	497	6438	508	4	2	B	11.3	A	9.9
Nuevo Rd On Ramp	Merge	6560	544	5930	438	4	1	C	23.5	C	21.8
Placentia Ave Off Ramp	Diverge	7104	457	6368	421	4	1	D	31.1	C	27.9
Placentia Ave On Ramp	Merge	6647	346	5947	475	4	1	C	23.7	C	21.9
Cajalco/Ramona Expwy Off Ramp	Diverge	6993	562	6422	633	4	1	D	31.2	D	29.3
Cajalco/Ramona Expwy On Ramp	Merge	6431	1230	5789	1039	4	1	C	23.6	C	22.2
Harley Knox Blvd Off Ramp	Diverge	7661	388	6828	368	4	1	D	33.0	D	29.5
Harley Knox Blvd On Ramp	Merge	7273	609	6460	803	4	1	C	25.3	C	23.4
Van Buren Blvd Off Ramp	Diverge	7882	915	7263	838	4	2	B	16.2	B	14.2
Van Buren Blvd EB On Ramp	Merge	6967	551	6425	508	3	1	F	53.3	F	49.4
Van Buren Blvd WB On Ramp	Merge	7518	150	6933	170	3	1	F	53.3	F	49.4
Cactus Ave Off Ramp	Diverge	7668	888	7103	719	3	1	F	53.3	F	49.4
Cactus Ave EB On Ramp	Merge	6780	167	6384	245	3	1	F	50.0	E	35.1
Cactus Ave WB On Ramp	Merge	6947	249	6629	367	3	1	F	50.0	F	48.7
Alessandro Blvd Off Ramp	Diverge	7196	926	6996	917	3	1	F	50.0	F	48.7
Alessandro Blvd On Ramp	Merge	6270	516	6025	667	3	1	F	47.2	F	46.9

(1) Capacity analysis shown for ramps only. See separate page of Table 6-5 for freeway mainline and HOV lanes.

(2) LOS = Level of Service.

(3) Density is expressed in passenger cars/mile/lane. For facilities at level of service F, the density shown is the theoretical density that would occur if all demand could be accommodated based on capacity of the adjacent freeway segment.

(4) For weaving volumes, see Figure 6-17c. The ramp to ramp movement was assumed to be zero. Weaving length is 2,000 feet per the I-215 widening project.

(5) Ramp capacity analysis shown for information only, since this is technically part of a weaving section.

Table 6-5 (cont.)
Opening Year (2020)
Freeway and HOV Lane Capacity Analysis (1)
Interstate 215 - Build

Southbound		Peak Hour Traffic (veh/hr)				Number of Lanes		Freeway Mainline and HOV Lane Level of Service (2)				
		AM		PM				Freeway Capacity (3)	AM Peak Hour		PM Peak Hour	
Location	Facility	Freeway	HOV	Freeway	HOV	Freeway	HOV		LOS (4)	Density (5)	LOS (4)	Density (5)
I - 215 Mainline												
North of Alessandro Blvd	Freeway	6069		8108		3		6470	E	38.7	F	56.4
North of Alessandro Blvd	HOV		1800		1800		1	6470	D	32.2	D	32.2
Alessandro Blvd On Ramp to Cactus Ave Off Ramp	Freeway	6292		8342		3		6470	E	41.9	F	58.0
Alessandro Blvd On Ramp to Cactus Ave Off Ramp	HOV		1800		1800		1	6470	D	32.2	D	32.2
Cactus Ave On Ramp to Van Buren Blvd Off Ramp	Freeway	6476		8603		3		6470	E	45.0	F	59.8
Cactus Ave On Ramp to Van Buren Blvd Off Ramp	HOV		1800		1800		1	6470	D	32.2	D	32.2
Van Buren Blvd On Ramp to Harley Knox Blvd Off Ramp	Freeway	6596		8869		4		8690	D	27.6	F	45.9
Van Buren Blvd On Ramp to Harley Knox Blvd Off Ramp	HOV		1800		1800		1	8690	D	32.2	D	32.2
Harley Knox Blvd On Ramp to Cajalco/Ramona Expwy Off Ramp	Freeway	6122		8593		4		8690	C	25.4	E	43.7
Harley Knox Blvd On Ramp to Cajalco/Ramona Expwy Off Ramp	HOV		1800		1800		1	8690	D	32.2	D	32.2
Cajalco/Ramona Expwy On Ramp to Placentia Ave Off Ramp	Freeway	5768		7969		4		8690	C	23.8	E	36.9
Cajalco/Ramona Expwy On Ramp to Placentia Ave Off Ramp	HOV		1800		1800		1	8690	D	32.2	D	32.2
Placentia Ave On Ramp to Nuevo Rd Off Ramp	Freeway	5720		8095		4		8690	C	23.6	E	38.1
Placentia Ave On Ramp to Nuevo Rd Off Ramp	HOV		1800		1800		1	8690	D	32.2	D	32.2

(1) Capacity Analysis shown for freeway mainline and HOV lanes. See separate page of Table 6-2 for ramps.

(2) One-lane HOV Lane density and level of service calculated using conditions for two freeway lanes and doubling the peak hour traffic.

(3) Freeway capacity is defined as the capacity at level of service E, expressed in vehicles per hour.

(4) LOS = Level of Service.

(5) Density is expressed in passenger cars/mile/lane. For facilities at level of service F, the density shown is the theoretical density that would occur if all demand could be accommodated.

Table 6-5 (cont.)
Opening Year (2020)
Ramp Capacity Analysis
Interstate 215 - Build

Southbound		Peak Hour Traffic (veh/hr)				Number of Lanes		Ramp Level of Service			
		AM		PM				AM Peak Hour		PM Peak Hour	
Location	Facility	Freeway	Ramp	Freeway	Ramp	Freeway	Ramp	LOS (1)	Density (2)	LOS (1)	Density (2)
I - 215 Mainline											
Alessandro Blvd Off Ramp	Diverge	6069	509	8108	665	3	1	D	34.1	F	56.4
Alessandro Blvd WB On Ramp	Merge	5560	220	7443	299	3	1	D	32.0	F	58.0
Alessandro Blvd EB On Ramp	Merge	5780	512	7742	600	3	1	E	35.4	F	58.0
Cactus Ave WB Off Ramp	Diverge	6292	327	8342	282	3	1	D	34.7	F	58.0
Cactus Ave EB Off Ramp	Diverge	5965	218	8060	188	3	1	D	33.3	F	58.0
Cactus Ave On Ramp	Merge	5747	729	7872	731	3	1	E	37.0	F	59.8
Van Buren Blvd Off Ramp	Diverge	6476	599	8603	674	3	1	E	35.8	F	59.8
Van Buren Blvd On Ramp	Merge (4)	5877	719	7929	940	3	1	E	37.5	F	45.9
Harley Knox Blvd Off Ramp	Diverge	6596	698	8869	665	4	1	D	30.3	F	45.9
Harley Knox Blvd On Ramp	Merge	5898	224	8204	389	4	1	C	21.4	C	28.0
Cajalco/Ramona Expwy Off Ramp	Diverge	6122	906	8593	1223	4	1	D	29.5	F	45.0
Cajalco/Ramona Expwy On Ramp	Merge	5216	552	7370	599	4	1	C	20.1	C	25.7
Placentia Ave Off Ramp	Diverge	5768	422	7969	389	4	1	C	25.5	D	34.3
Placentia Ave On Ramp	Merge	5346	374	7580	515	4	1	C	20.1	C	26.2
Nuevo Rd Off Ramp	Diverge	5720	317	8095	657	3	1	D	32.4	F	45.0
Nuevo Rd On Ramp	Merge (5)	5403	425	7438	568	3	1	D	32.8	F	45.0
Nuevo Rd On Ramp to D Street Off Ramp	Weave (6)	5828		8006		4		C	27.9	E	42.1

(1) Capacity analysis shown for ramps only. See separate page of Table 7-2 for freeway mainline and HOV lanes.

(2) LOS = Level of Service.

(3) Density is expressed in passenger cars/mile/lane. For facilities at level of service F, the density shown is the theoretical density that would occur if all demand could be accommodated based on capacity of the adjacent freeway segment.

(4) Level of service and density of downstream freeway since lanes are added to the freeway at this point.

(5) Ramp capacity analysis shown for information only, since this is technically part of a weaving section.

(6) For weaving volumes, see Figure 6-17c. The ramp to ramp movement was assumed to be zero. Weaving length is 2,000 feet per the I-215 widening project.

Table 6-6
Horizon Year (2020)
Freeway Capacity Analysis (1)
Mid County Parkway - Build

Eastbound		Peak Hour Traffic (veh/hr)		Number of Lanes	Capacity (2)	Freeway Mainline Level of Service			
Location	Facility	AM	PM			AM Peak Hour		PM Peak Hour	
						LOS (3)	Density (4)	LOS (3)	Density (4)
Mid County Parkway									
West of Reservoir Ave	Freeway	1273	1880	2	4290	A	11.0	B	16.2
Reservoir Ave On Ramp to Town Center Blvd Off Ramp	Freeway	1454	2000	2	4290	B	12.5	B	17.2
Town Center Blvd On Ramp to Park Center Blvd Off Ramp	Freeway	1317	1740	2	4290	B	11.3	B	15.0
East of Park Center Blvd	Freeway	1275	1607	2	4290	A	11.0	B	13.9

(1) Capacity Analysis shown for freeway mainline. See separate page of Table 6-6 for ramps.

(2) Freeway capacity is defined as the capacity at level of service E, expressed in vehicles per hour

(3) LOS = Level of Service

(4) Density is expressed in passenger cars/mile per lane.

Table 6-6 (cont.)
Horizon Year (2020)
Ramp Capacity Analysis (1)
Mid County Parkway - Build

Eastbound		Peak Hour Traffic (veh/hr)				Number of Lanes		Ramp Level of Service			
		AM		PM				AM Peak Hour		PM Peak Hour	
Location	Facility	Freeway	Ramp	Freeway	Ramp	Freeway	Ramp	LOS (2)	Density (3)	LOS (2)	Density (3)
Mid County Parkway											
Reservoir Ave Off Ramp	Diverge	1273	113	1880	139	2	1	B	11.6	B	17.3
Reservoir Ave SB On Ramp	Merge	1172	101	1741	104	2	1	B	13.1	B	17.9
Reservoir Ave NB On Ramp	Merge	1285	169	1845	155	2	1	B	14.6	B	19.2
Town Center Blvd Off Ramp	Diverge	1454	295	2000	406	2	1	B	13.3	B	18.4
Town Center Blvd On Ramp	Merge	1159	158	1594	146	2	1	B	13.4	B	17.0
Park Center Blvd Off Ramp	Diverge	1317	209	1740	287	2	1	B	12.1	B	16.0
Park Center Blvd On Ramp	Merge	1108	167	1453	154	2	1	B	13.1	B	15.9

(1) Capacity analysis shown for ramps only. See separate page of Table 6-6 for freeway mainline and HOV lanes.

(2) LOS = Level of Service.

(3) Density is expressed in passenger cars/mile/lane. For facilities at level of service F, the density shown is the theoretical density that would occur if all demand could be accommodated based on capacity of the adjacent freeway segment.

Table 6-6 (cont.)
Horizon Year (2020)
Freeway Capacity Analysis (1)
Mid County Parkway - Build

Westbound		Peak Hour Traffic (veh/hr)			Freeway Mainline Level of Service				
Location	Facility	AM	PM	Number of Lanes	Capacity (2)	AM Peak Hour		PM Peak Hour	
						LOS (3)	Density (4)	LOS (3)	Density (4)
Mid County Parkway									
East of Park Center Blvd	Freeway	1429	1435	2	4290	B	12.3	B	12.4
Park Center Blvd On Ramp to Town Center Blvd Off Ramp	Freeway	1547	1482	2	4290	B	13.3	B	12.8
Town Center Blvd On Ramp to Reservoir Ave Off Ramp	Freeway	1778	1636	2	4290	B	15.3	B	14.1
West of Reservoir Ave	Freeway	1662	1432	2	4290	B	14.3	B	12.3

(1) Capacity Analysis shown for freeway mainline. See separate page of Table 6-6 for ramps.

(2) Freeway capacity is defined as the capacity at level of service E, expressed in vehicles per hour

(3) LOS = Level of Service

(4) Density is expressed in passenger cars/mile per lane.

Table 6-6 (cont.)
Horizon Year (2020)
Ramp Capacity Analysis (1)
Mid County Parkway - Build

Westbound		Peak Hour Traffic (veh/hr)				Number of Lanes		Freeway Mainline and Ramp Level of Service			
		AM		PM				AM Peak Hour		PM Peak Hour	
Location	Facility	Freeway	Ramp	Freeway	Ramp	Freeway	Ramp	LOS (2)	Density (3)	LOS (2)	Density (3)
Mid County Parkway											
Park Center Blvd Off Ramp	Diverge	1429	137	1435	188	2	1	B	13.1	B	13.2
Park Center Blvd NB On Ramp	Merge	1292	153	1247	141	2	1	B	14.5	B	14.0
Park Center Blvd SB On Ramp	Merge	1445	102	1388	94	2	1	B	15.4	B	14.9
Town Center Blvd Off Ramp	Diverge	1547	130	1482	178	2	1	B	14.2	B	13.6
Town Center Blvd On Ramp	Merge	1417	361	1304	332	2	1	B	17.2	B	16.0
Reservoir Ave Off Ramp	Diverge	1778	239	1636	317	2	1	B	16.4	B	15.0
Reservoir Ave On Ramp	Merge	1539	123	1319	113	2	1	B	16.4	B	14.4

(1) Capacity analysis shown for ramps only. See separate page of Table 6-6 for freeway mainline and HOV lanes.

(2) LOS = Level of Service.

(3) Density is expressed in passenger cars/mile/lane. For facilities at level of service F, the density shown is the theoretical density that would occur if all demand could be accommodated based on capacity of the adjacent freeway segment.

Table 6-7
Horizon Year (2020)
Intersection Capacity Analysis - Build
I-15 Area

Intersection	AM Peak Hour		PM Peak Hour	
	LOS	Average Delay (sec)	LOS	Average Delay (sec)
Magnolia Avenue and El Sobrante Road	F	>80.0	F	>80.0
Magnolia Avenue and I-15 Southbound Ramps	F	>80.0	F	>80.0
Magnolia Avenue and I-15 Northbound Ramps	C	21.7	B	17.1
Magnolia Avenue and El Camino Avenue	B	14.3	C	23.4
Ontario Avenue and California Avenue	C	27.9	D	48.3
Ontario Avenue and I-15 Southbound Ramps	B	10.8	B	15.2
Ontario Avenue and I-15 Northbound Ramps	C	31.0	C	28.7
Ontario Avenue and State Street	B	12.9	B	11.0
El Cerrito Road and Bedford Canyon Road	B	15.7	B	18.7
El Cerrito Road and I-15 Southbound Ramps	B	13.1	B	13.9
El Cerrito Road and I-15 Northbound Ramps	C	29.9	C	27.6
El Cerrito Road and Temescal Canyon Road	C	25.1	B	18.8
Cajalco Road and Bedford Canyon Road	B	17.1	C	26.1
Cajalco Road and I-15 Southbound Ramps	C	24.0	C	23.5
Cajalco Road and I-15 Northbound Ramps	B	12.3	B	11.6
Cajalco Road and Temescal Canyon Road	C	29.0	D	37.9
Weirick Road and Knabe Road	C	28.3	C	28.4
Weirick Road and I-15 Southbound Ramps	C	21.5	C	23.3
Weirick Road and I-15 Northbound Ramps	B	10.7	A	9.8
Weirick Road and Temescal Canyon Road	C	23.7	C	27.4
Temescal Canyon Road and Lawson Drive	A	8.6	A	7.7
Temescal Canyon Road and I-15 Southbound Ramps	B	15.4	C	23.7
Temescal Canyon Road and I-15 Northbound Ramps	C	23.3	C	25.1

Notes:

">80" – Exceeds 80 seconds

Table 6-7 (cont.)
 Horizon Year (2020)
 Intersection Capacity Analysis - Build
 Cajalco Road, I-15 to I-215

Intersection	AM Peak Hour		PM Peak Hour	
	LOS	Average Delay (sec)	LOS	Average Delay (sec)
Eagle Valley Road and Cajalco Road	B	10.7	B	11.7
Lake Matthews Road and Cajalco Road	B	11.4	B	16.2
El Sobrante Road and Calalco Road	B	11.6	B	10.7
Wood Road and Cajalco Road	B	19.4	B	19.0
Alexander Street and Cajalco Road	B	17.3	B	13.8
Clark Street and Cajalco Road	B	17.9	B	19.7

Notes:

">80" – Exceeds 80 seconds

Table 6-7 (cont.)
Horizon Year (2020)
Intersection Capacity Analysis - Build
I-215 Area

Intersection	AM Peak Hour		PM Peak Hour	
	LOS	Average Delay (sec)	LOS	Average Delay (sec)
Alessandro Blvd and Meridian Parkway	D	37.5	F	>80.0
Alessandro Blvd and I-215 Southbound Ramps	B	10	C	25.6
Alessandro Blvd and I-215 Northbound Ramps	C	22.8	D	40.8
Alessandro Blvd and Valley Springs Parkway	C	24.3	D	52.6
Cactus Avenue and Innovation Drive	B	16.8	B	17.1
Cactus Avenue and I-215 Southbound Ramps	B	14.1	B	13.8
Cactus Avenue and I-215 Northbound Ramps	C	24.5	C	22.7
Cactus Avenue and Ellsworth Street	D	47.9	C	32.3
Van Buren Boulevard and Meridian Parkway	C	26.8	C	31.9
Van Buren Boulevard and I-215 Southbound Ramps	B	11.5	B	11.1
Van Buren Boulevard and I-215 Northbound Ramps	B	18.9	B	18.6
Harley Knox Blvd and Harvill Avenue	B	14.5	B	13.6
Harley Knox Blvd and I-215 Southbound Ramps	C	24.3	C	23.1
Harley Knox Blvd and I-215 Northbound Ramps	B	17.8	C	20.9
Harley Knox Blvd and Western Way	A	6.0	A	7.6
Cajalco Road and Harvill Avenue	C	29.8	C	32.0
Cajalco Road and I-215 Southbound Ramps	C	25.4	C	32.5
Cajalco Road and I-215 Northbound Ramps	D	44.9	C	33.4
Ramona Expressway and Webster Avenue	D	42.3	D	38.9
Placentia Avenue and Harvill Avenue	C	31.2	D	36.6
Placentia Avenue and I-215 Southbound Ramps	B	14.3	B	14.6
Placentia Avenue and I-215 Northbound Ramps	B	15.5	B	16.0
Placentia Avenue and East Frontage Road	B	10.8	A	9.3
Nuevo Road and A Street	B	12.1	B	17.9
Nuevo Road and I-215 Southbound Ramps	C	20.3	C	31.1
Nuevo Road and I-215 Northbound Ramps	B	10.7	B	16.7
Nuevo Road and Old Nuevo Road	C	30.3	C	33.4

Notes:

">80" – Exceeds 80 seconds

Table 6-7 (cont.)
Horizon Year (2020)
Intersection Capacity Analysis - Build
Ramona Expressway, I-215 to SR 79

Intersection	AM Peak Hour		PM Peak Hour	
	LOS	Average Delay (sec)	LOS	Average Delay (sec)
Perris Blvd and Markham St	C	31.2	D	46.6
Perris Blvd and Ramona Expressway	D	46.9	D	50.1
Perris Blvd and Morgan St	B	15.6	B	19.2
Evans Road and Marbella Gate	A	3.1	A	2.4
Evans Road and Ramona Expressway	C	34.8	C	32.4
Evans Road and Morgan St	A	9.6	A	9.0
Bernasconi Road and New St	B	11.3	B	10.9
Bernasconi Road and Ramona Expressway	C	23.3	C	24.7
Bernasconi Road and Orange Avenue	C	29.6	C	34.0
Reservoir Avenue and Martin St	D	39.4	C	33.1
Reservoir Avenue and MCP Westbound Ramps	B	14.9	B	16.5
Reservoir Avenue and MCP Eastbound Ramps	A	4.3	A	4.7
Reservoir Avenue and 9th Street	B	14.3	B	13.4
Town Center Boulevard and Frontage Rd	B	15.1	B	14.7
Town Center Boulevard and MCP Westbound Ramps	A	4.7	A	5.2
Town Center Boulevard and MCP Eastbound Ramps	B	12.8	A	9.0
Town Center Boulevard and 5th Street	C	23.9	C	22.0
Park Center Boulevard and Marvin Road	D	35.2	C	30.2
Park Center Boulevard and MCP Westbound Ramps	A	7.0	A	9.7
Park Center Boulevard and MCP Eastbound Ramps	B	10.9	B	13.0
Park Center Boulevard and New Street	A	6.5	A	6.8
Warren Road and Ramona Expressway	C	33.9	C	30.2
Warren Road and Record Road	A	8.1	A	9.1
Gilman Springs Road and SR 79 Southbound Ramps	B	17.1	B	15.3
Gilman Springs Road and SR 79 Northbound Ramps	C	20.1	C	17.7
Sanderson Ave and Ramona Expressway	C	24.5	C	26.8
Ramona Expressway and SR 79 Southbound Ramps	B	17.9	B	17.0
Ramona Expressway and SR 79 Northbound Ramps	C	21.9	C	21.4
SR 79 and Sanderson Ave	D	50.0	D	47.9
Lyon and Ramona Expressway	C	22.9	C	25.9
Sanderson Ave and Cottonwood Avenue	C	29.8	C	31.4

Notes:

">80" – Exceeds 80 seconds

7.0 HORIZON YEAR (2040) CONDITIONS

This Chapter provides analysis of expected 2040 No Build and Build traffic conditions. As described in Chapter 2, the analysis includes three alignment alternatives.

2040 NO BUILD TRAFFIC CONDITIONS

Traffic forecasts for No Build traffic conditions are provided in Figures 7-1 through 7-7. These traffic forecasts are common to both the No Build/Existing Conditions scenario and the No Build/County General Plan scenario. Figures 7-6 and 7-7 provide lane geometry assumptions for No Build conditions, which is also common to the two scenarios described above. Capacity analysis for No Build conditions that are common to these two scenarios is shown in Tables 7-1 and 7-2.

Figure 7-8 provides lane geometry assumptions for the No Build/Existing Conditions scenario, which assumes that no improvements beyond existing conditions along the Ramona Expressway from Interstate 215 (I-215) to State Route 79 (SR-79) will be constructed. Capacity analysis for this scenario is shown in Table 7-3.

Figure 7-9 provides lane geometry assumptions for the No Build/County General Plan scenario, which assumes improvements along the Ramona Expressway from I-215 to SR-79 consistent with the Riverside County General Plan Circulation Element. Capacity analysis for this scenario is shown in Table 7-4.

2040 ALTERNATIVE 4 MODIFIED TRAFFIC CONDITIONS

Traffic forecasts and lane geometry assumptions for Alternative 4 Modified are documented in Figures 7-10 through 7-23. Capacity analysis is shown in Tables 7-5 through 7-8.

2040 ALTERNATIVE 5 MODIFIED TRAFFIC CONDITIONS

Traffic forecasts and lane geometry assumptions for Alternative 5 Modified are documented in Figures 7-24 through 7-37. Capacity analysis is shown in Tables 7-9 through 7-12.

2040 ALTERNATIVE 9 MODIFIED TRAFFIC CONDITIONS

Traffic forecasts and lane geometry assumptions for Alternative 9 Modified are documented in Figures 7-38 through 7-52. Capacity analysis is shown in Tables 7-13 through 7-17.

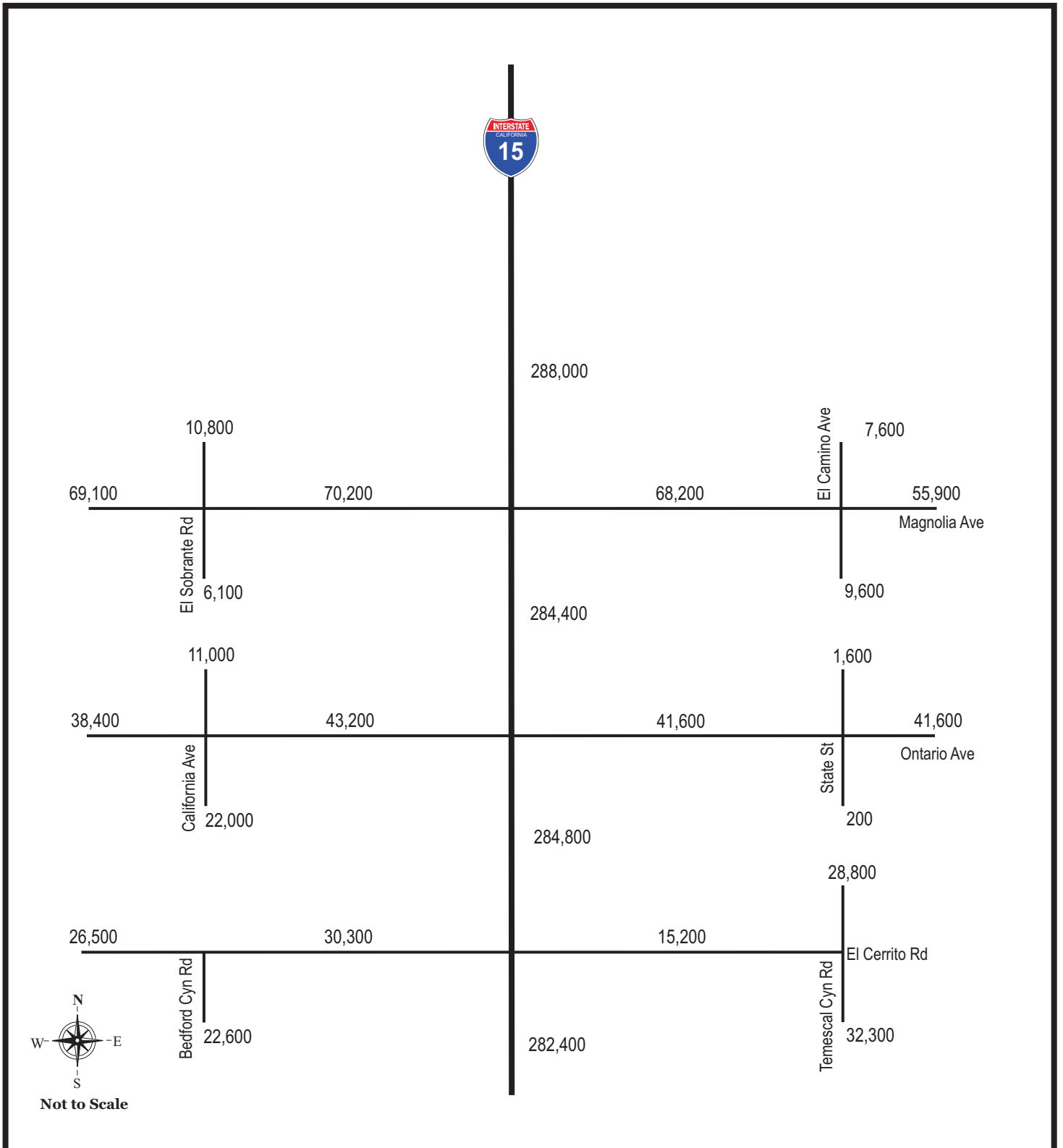

Horizon Year (2040) ADT - Freeway and Street Segments MCP Area - No Build

Figure 7-1a

Legend:

XX,XXX Average Daily Traffic



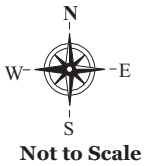
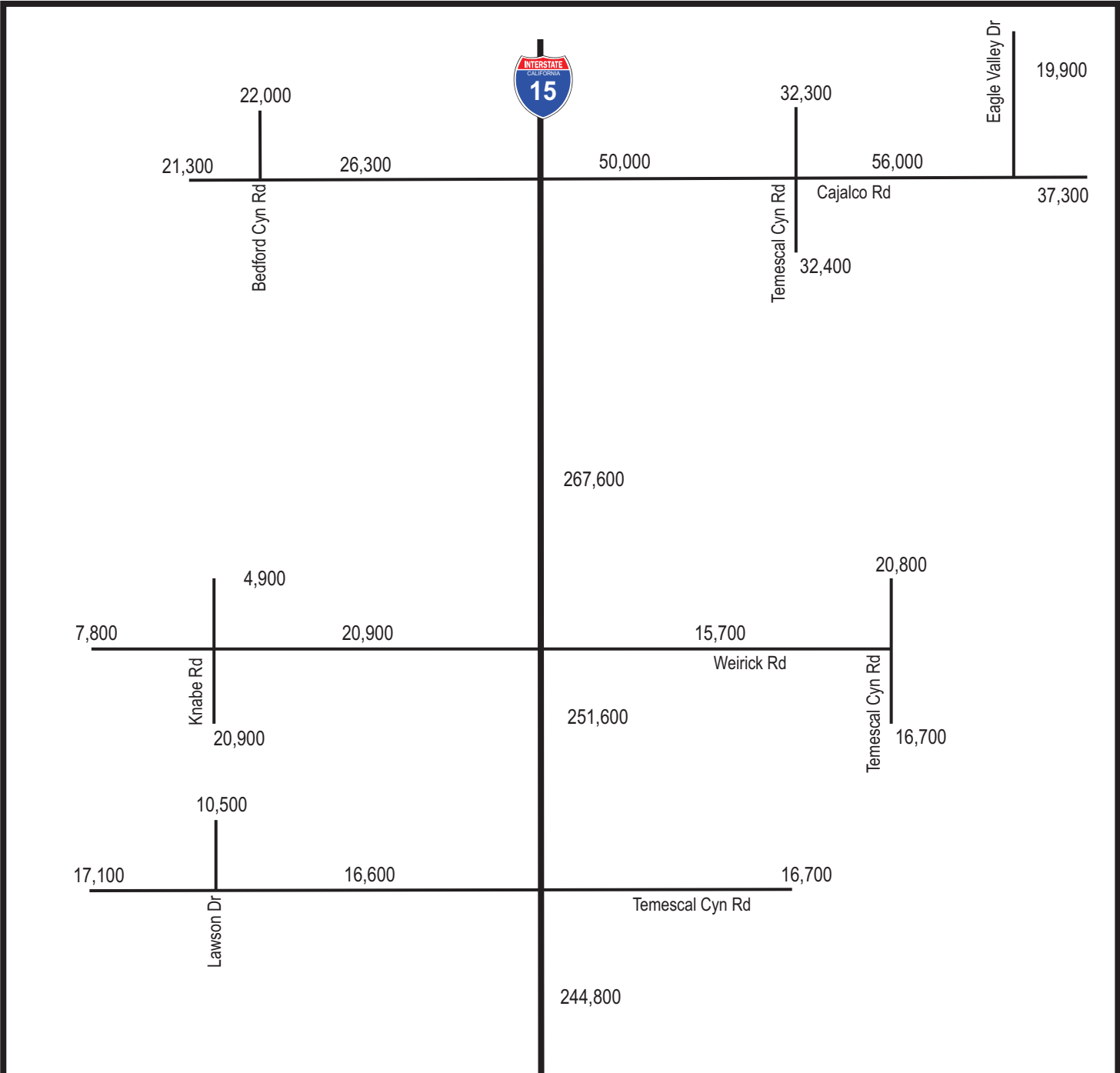

Horizon Year (2040) ADT - Freeway and Street Segments MCP Area - No Build

Figure 7-1b

Legend:

XX,XXX Average Daily Traffic



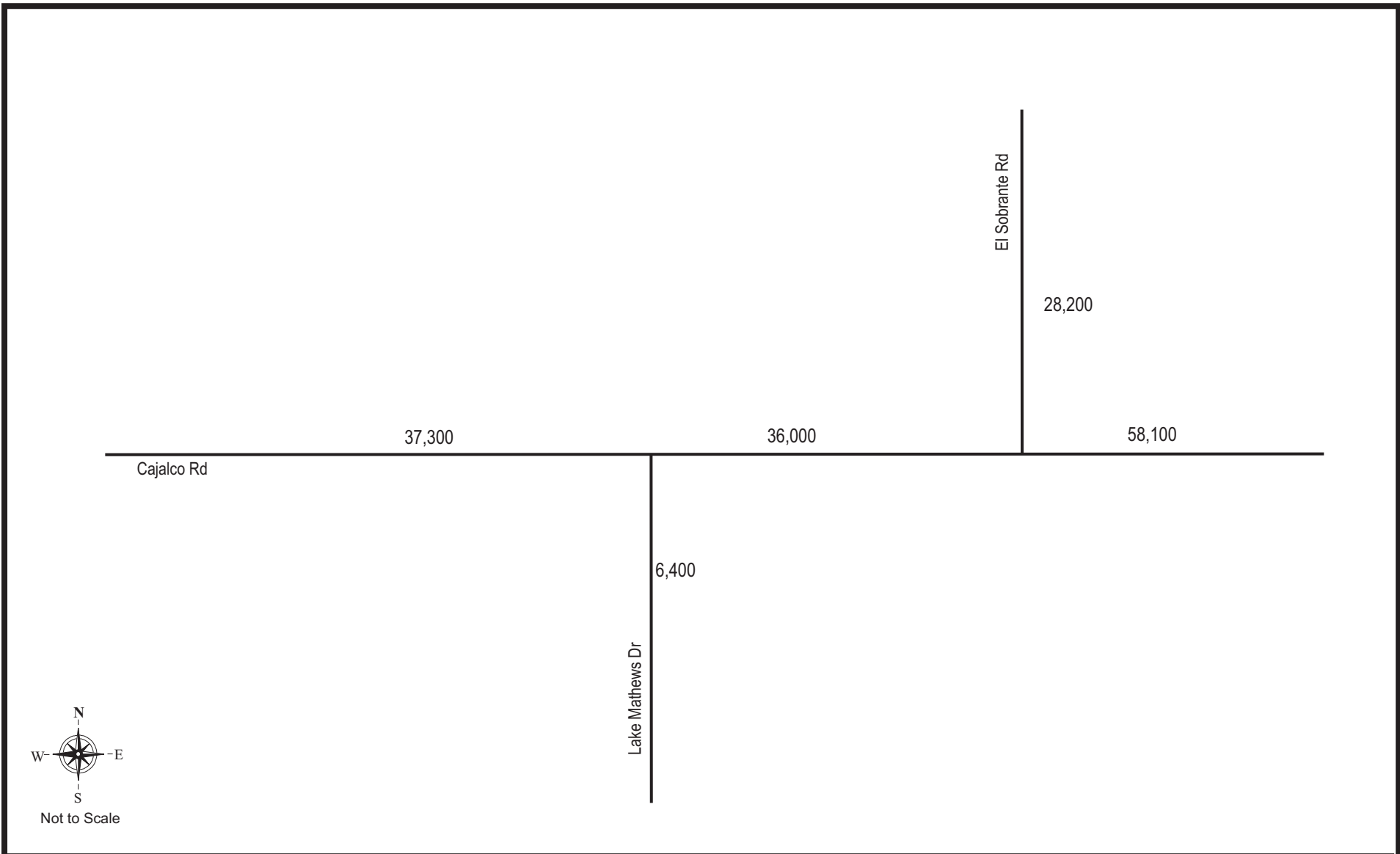

Horizon Year (2040) ADT - Freeway and Street Segments MCP Area - No Build

Figure 7-1c

Legend:

XX,XXX Average Daily Traffic



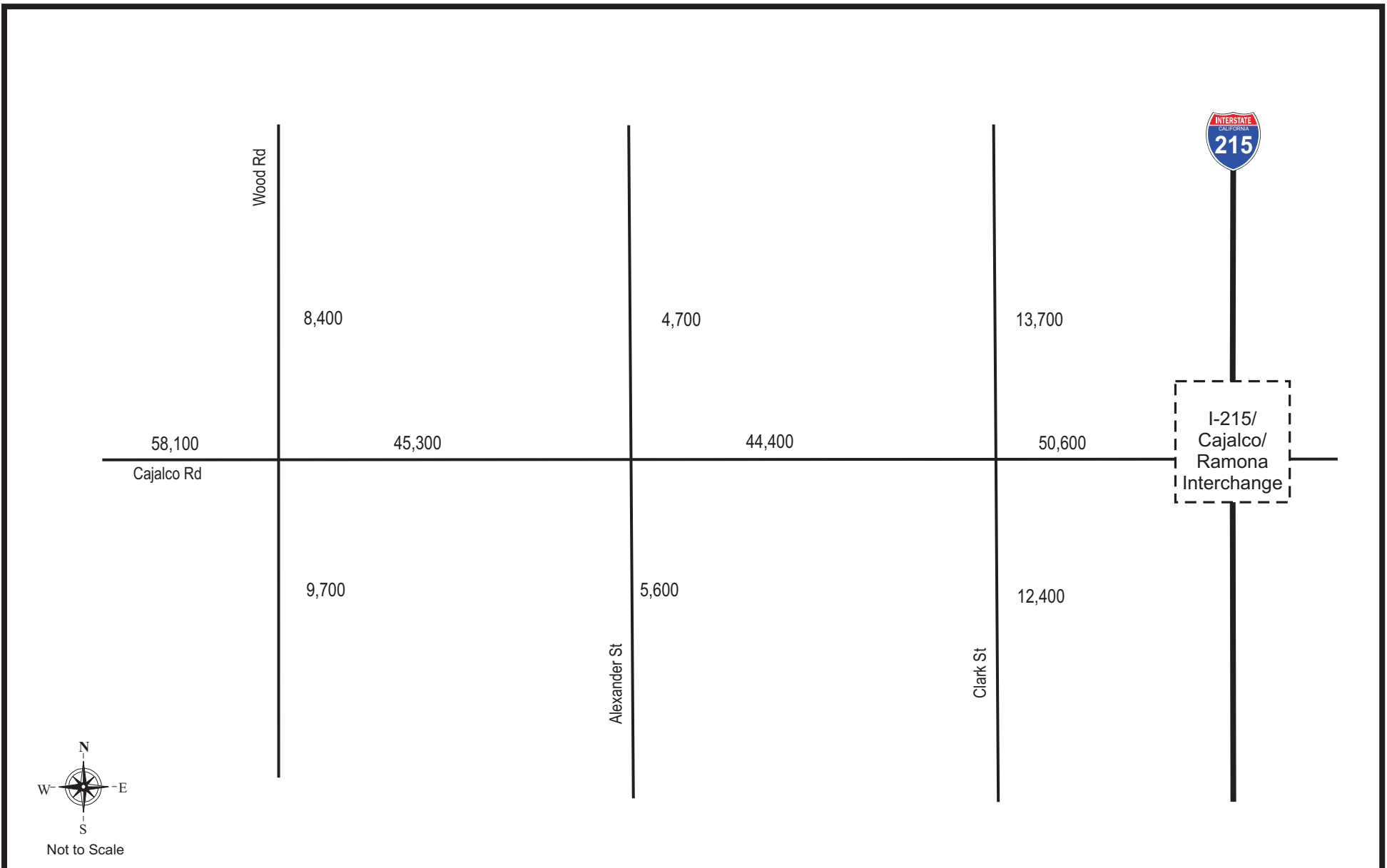

Horizon Year (2040) ADT - Freeway and Street Segments MCP Area - No Build

Figure 7-1d

Legend:

XX,XXX Average Daily Traffic



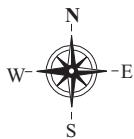
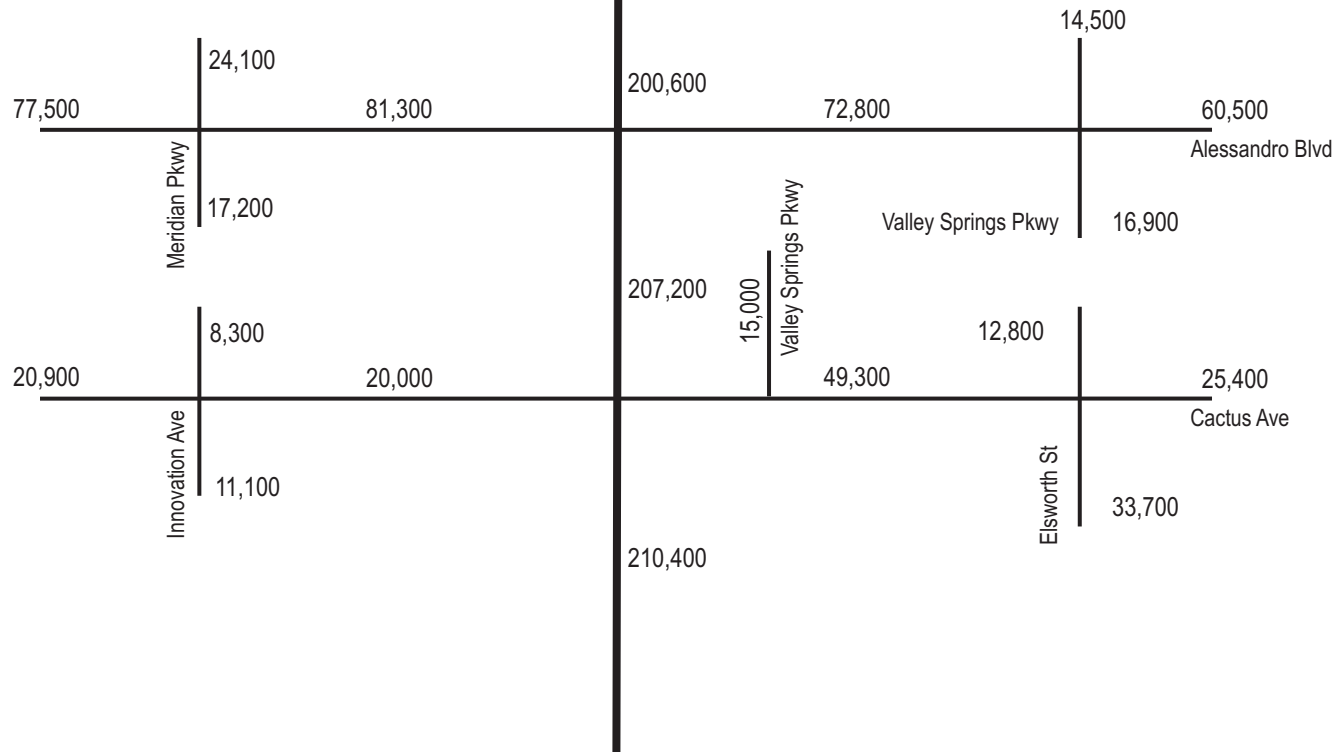

Not to Scale

Horizon Year (2040) ADT - Freeway and Street Segments MCP Area - No Build

Figure 7-1e

Legend:

XX,XXX Average Daily Traffic



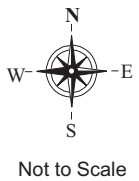

Horizon Year (2040) ADT - Freeway and Street Segments MCP Area - No Build

Figure 7-1f

Legend:

XX,XXX Average Daily Traffic



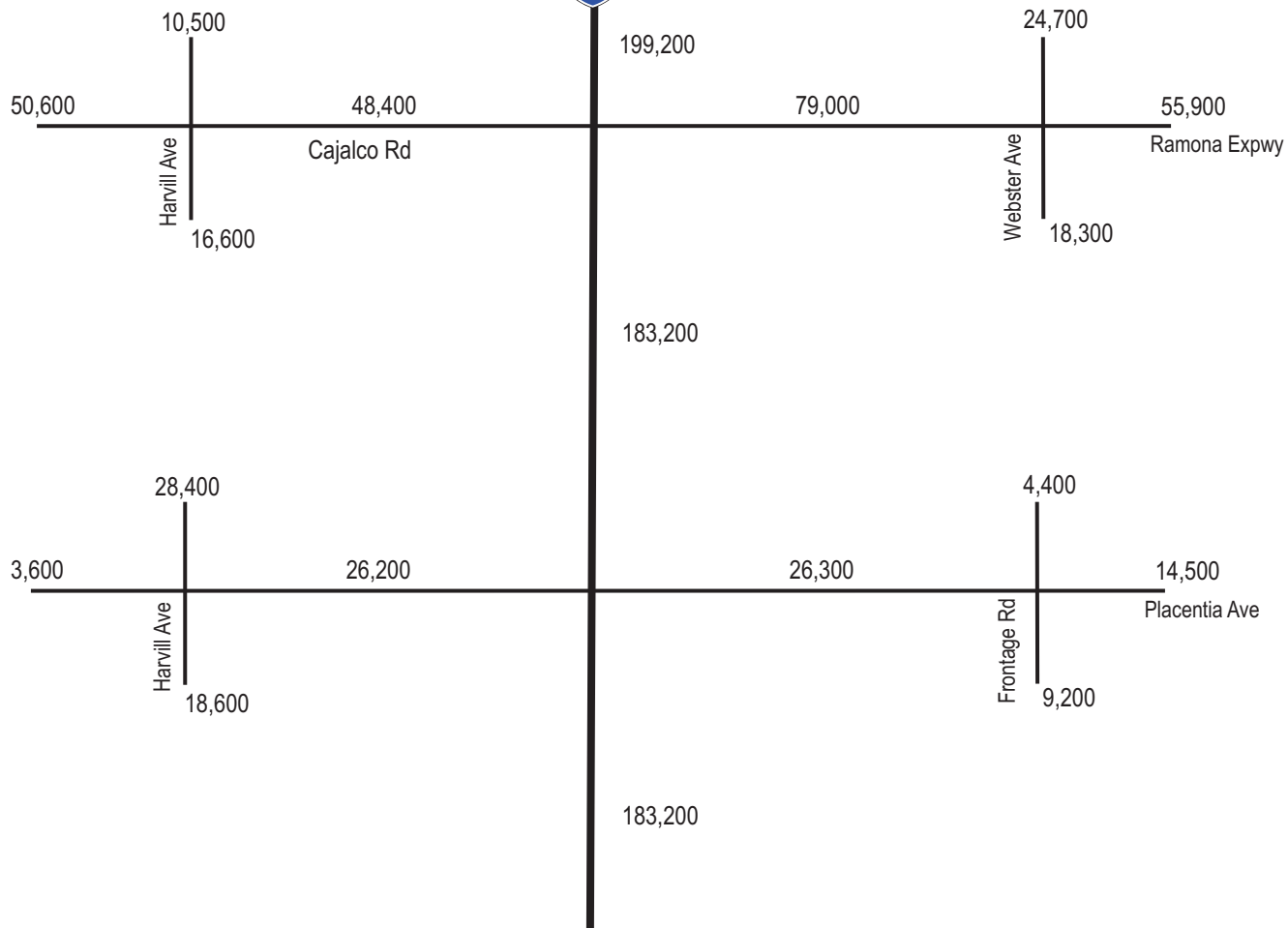

Horizon Year (2040) ADT - Freeway and Street Segments MCP Area - No Build

Figure 7-1g

Legend:

XX,XXX Average Daily Traffic



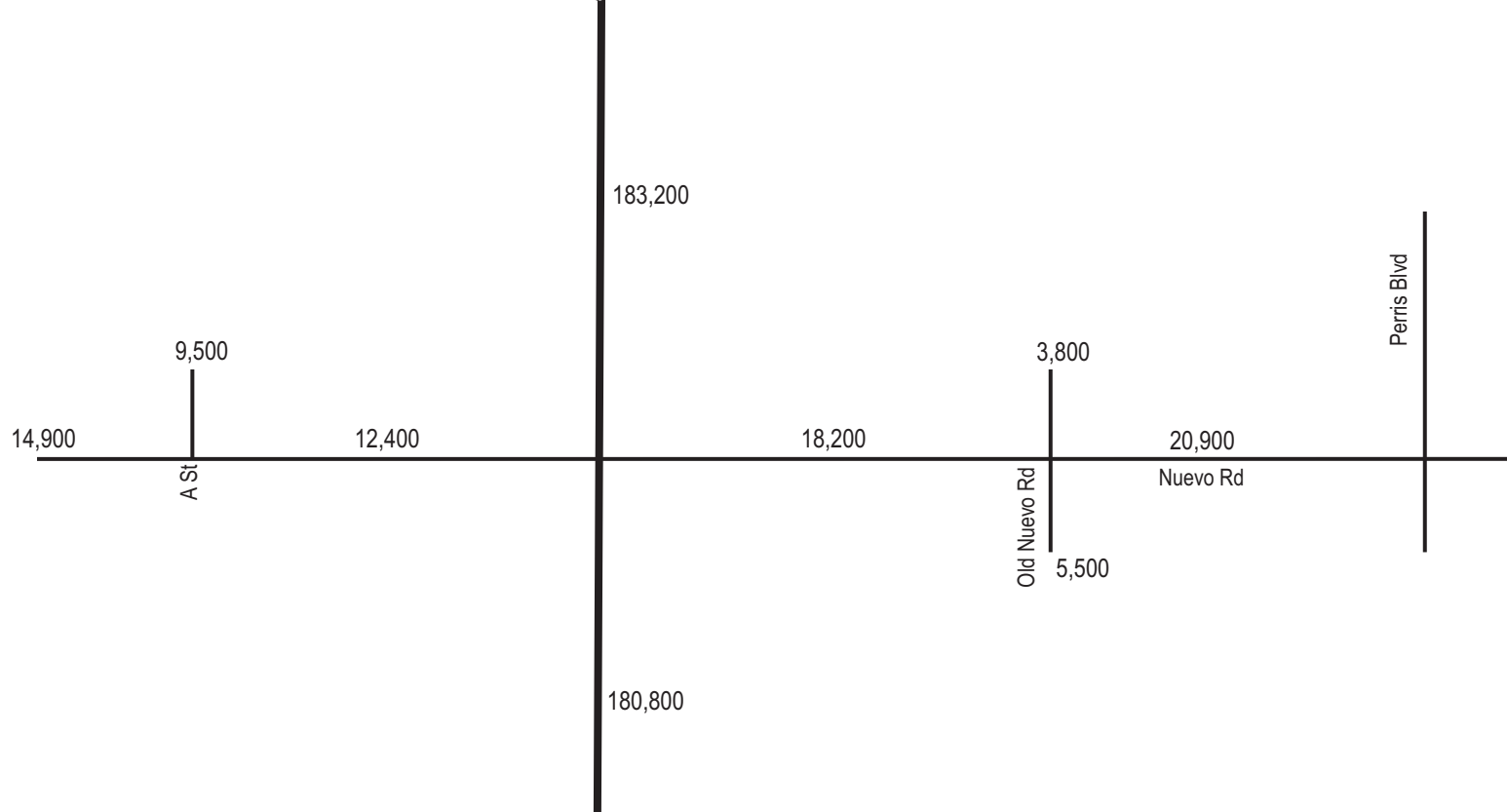

Not to Scale

Horizon Year (2040) ADT - Freeway and Street Segments MCP Area - No Build

Figure 7-1h

Legend:

XX,XXX Average Daily Traffic



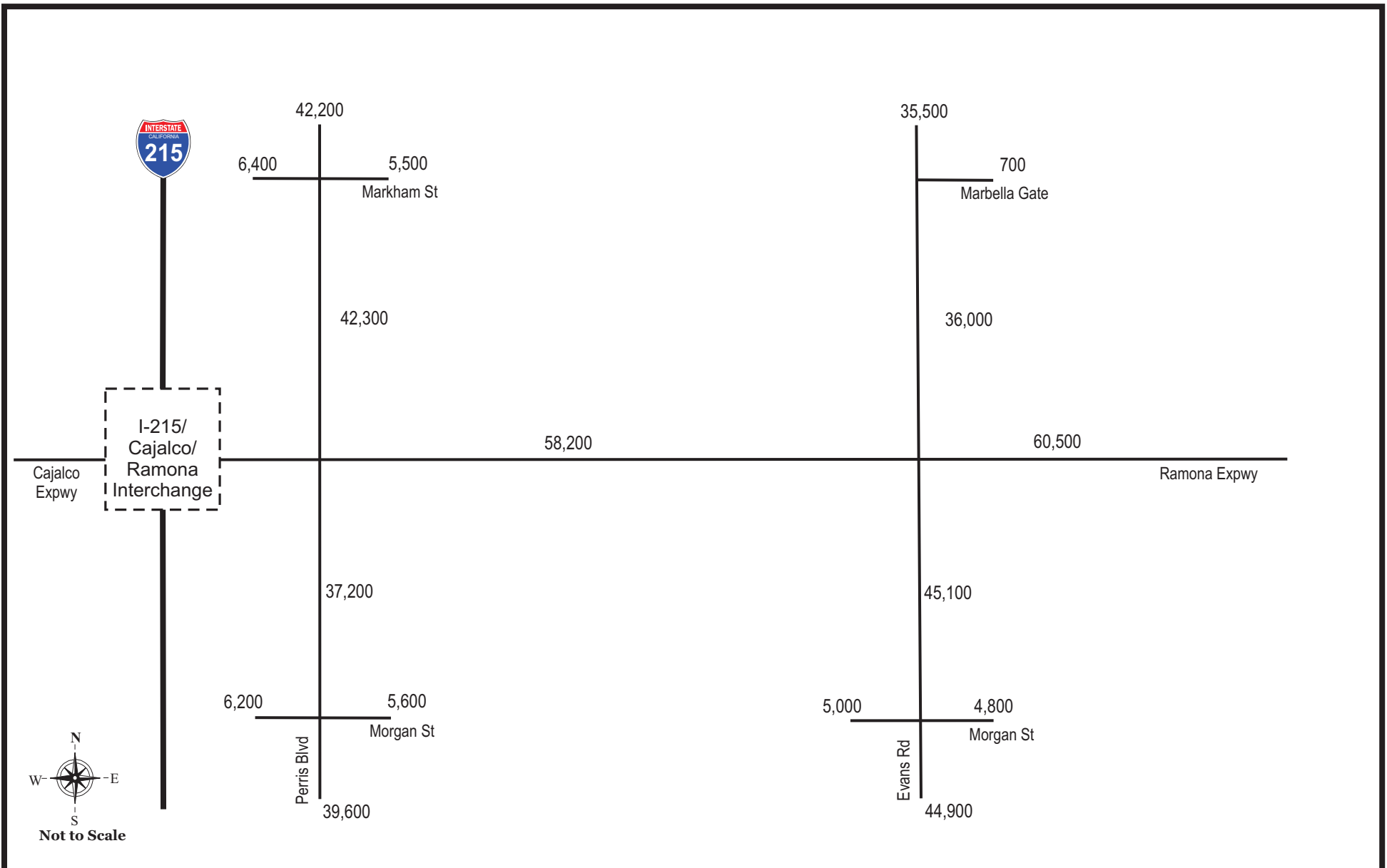

Horizon Year (2040) ADT - Freeway and Street Segments MCP Area - No Build

Figure 7-1i

Legend:

XX,XXX Average Daily Traffic



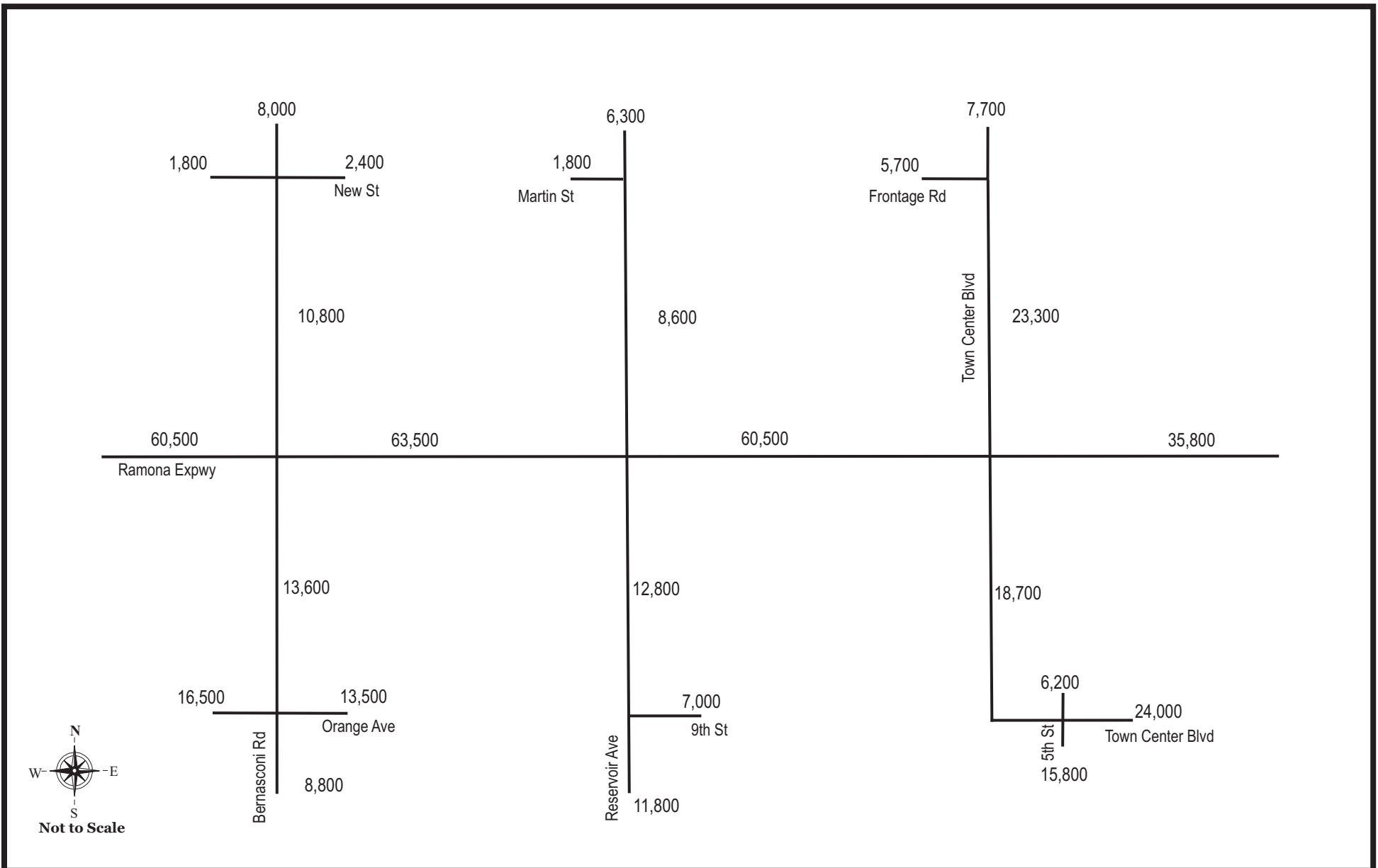

Horizon Year (2040) ADT - Freeway and Street Segments MCP Area - No Build

Figure 7-1j

Legend:

XX,XXX Average Daily Traffic



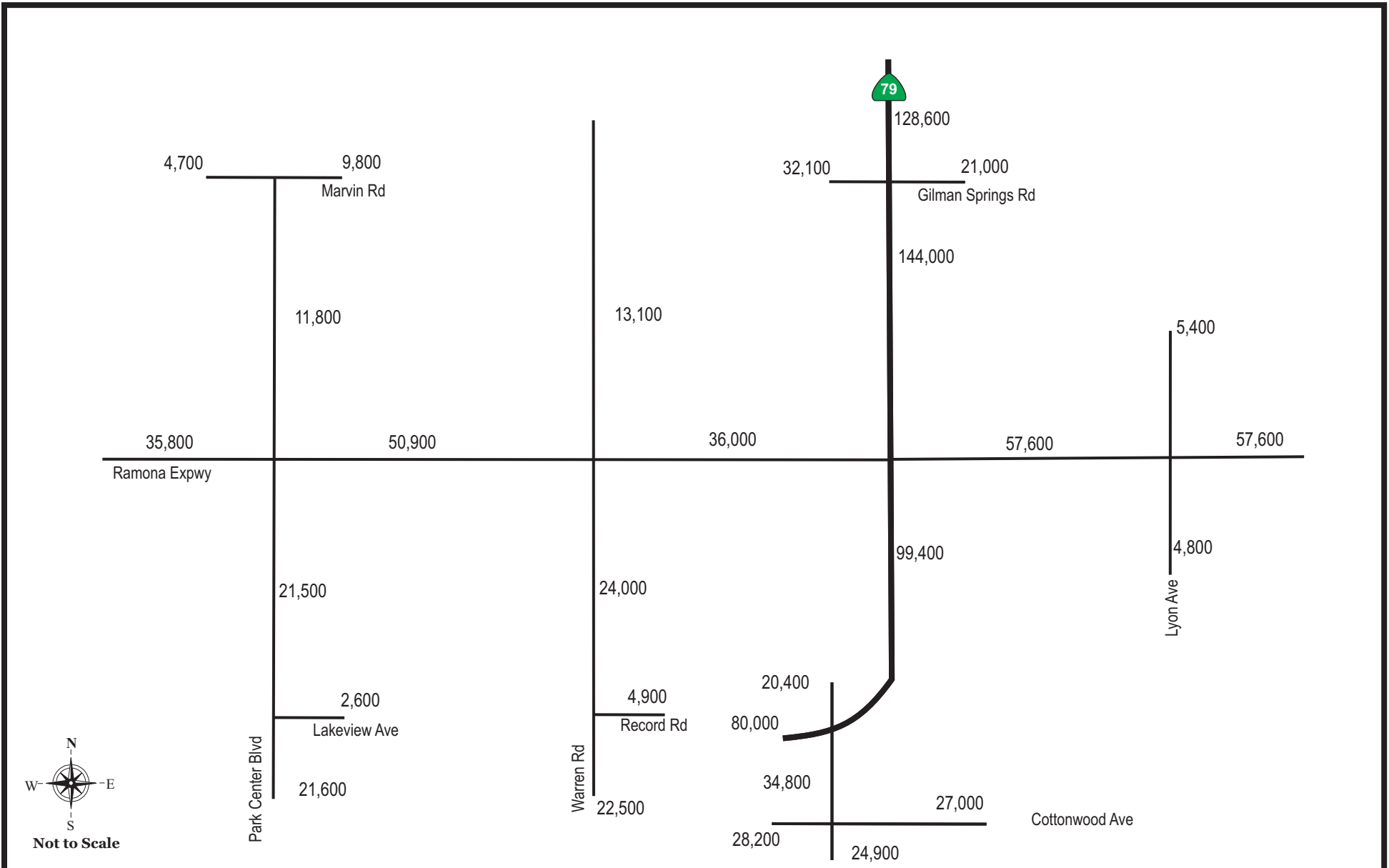

Horizon Year (2040) ADT - Freeway and Street Segments MCP Area - No Build

Figure 7-1k

Legend:

XX,XXX Average Daily Traffic



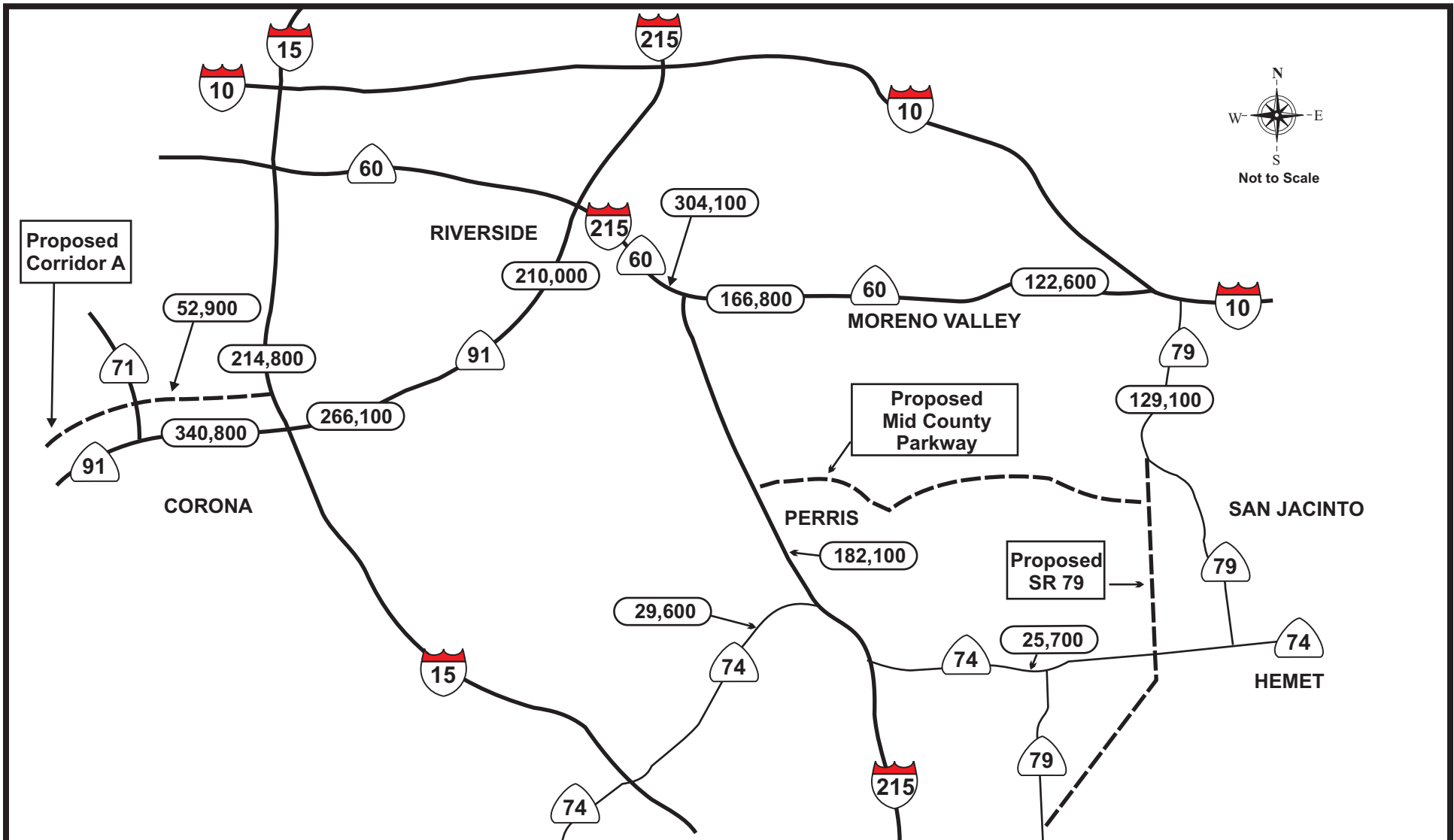

Horizon Year (2040) ADT Freeway and Street Segments Outside MCP Area - No Build

Figure 7-2

Legend

- Existing Limited Access Roadway
- Existing Arterial Roadway
- - - Proposed Limited Access Roadway
- (XXX,XXX) Average Daily Traffic



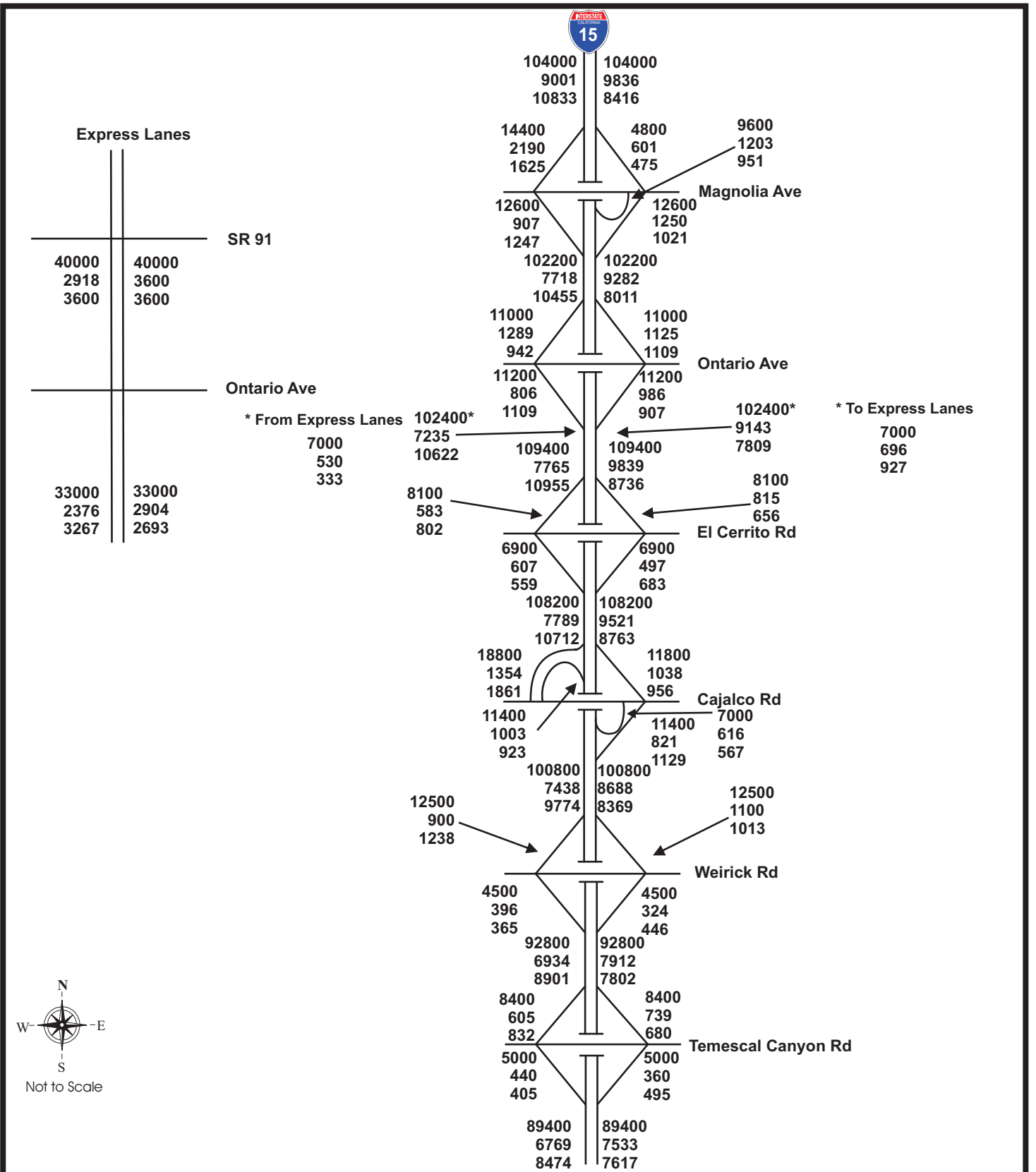

**Horizon Year (2040) Freeway and Ramp Traffic
Interstate 15 - No Build**

Figure 7-3

Legend

- XXXXX** ADT
- XXXX** AM Peak Hour
- XXXX** PM Peak Hour



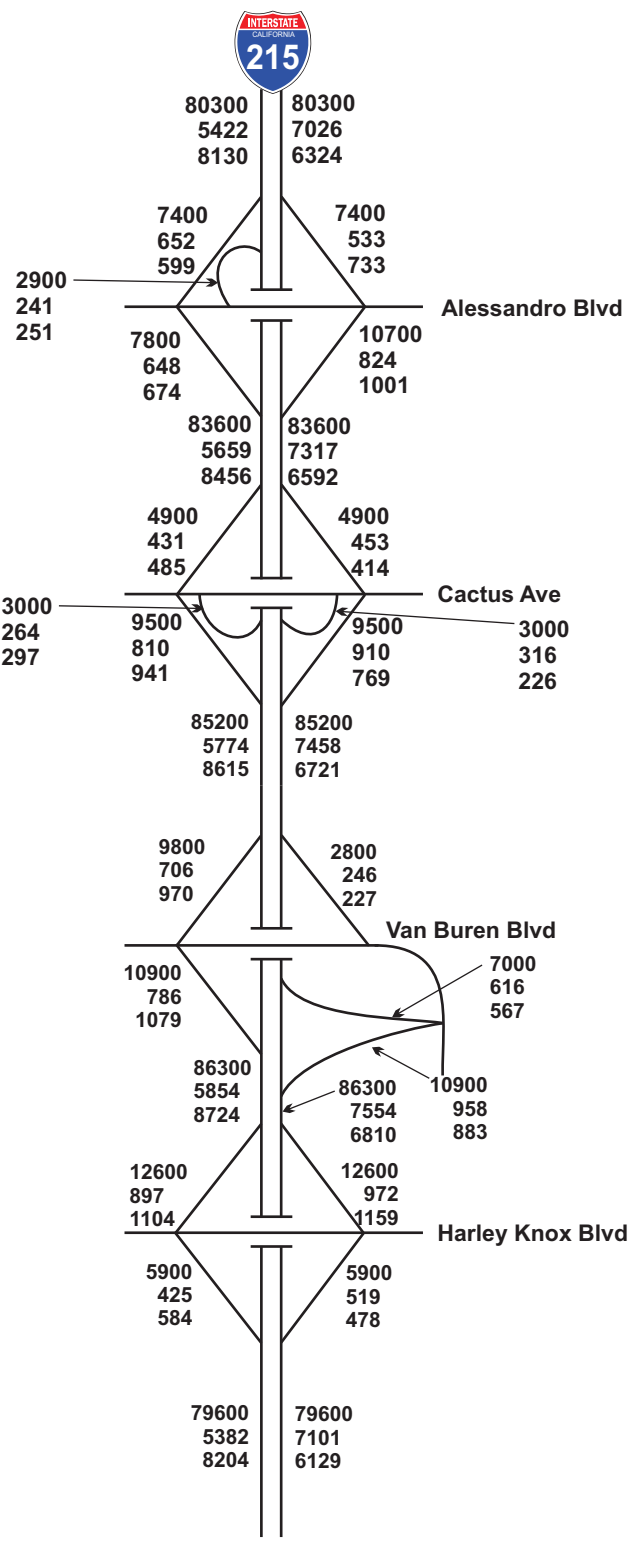
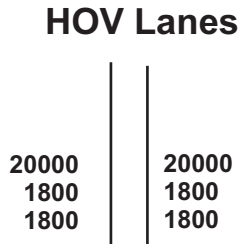

**Horizon Year (2040)
Freeway and Ramp Traffic
Interstate 215 - No Build**

Figure 7-4a

Legend

XXXXX Average Daily Traffic
 XXX AM Peak Hour Traffic
 XXX PM Peak Hour Traffic



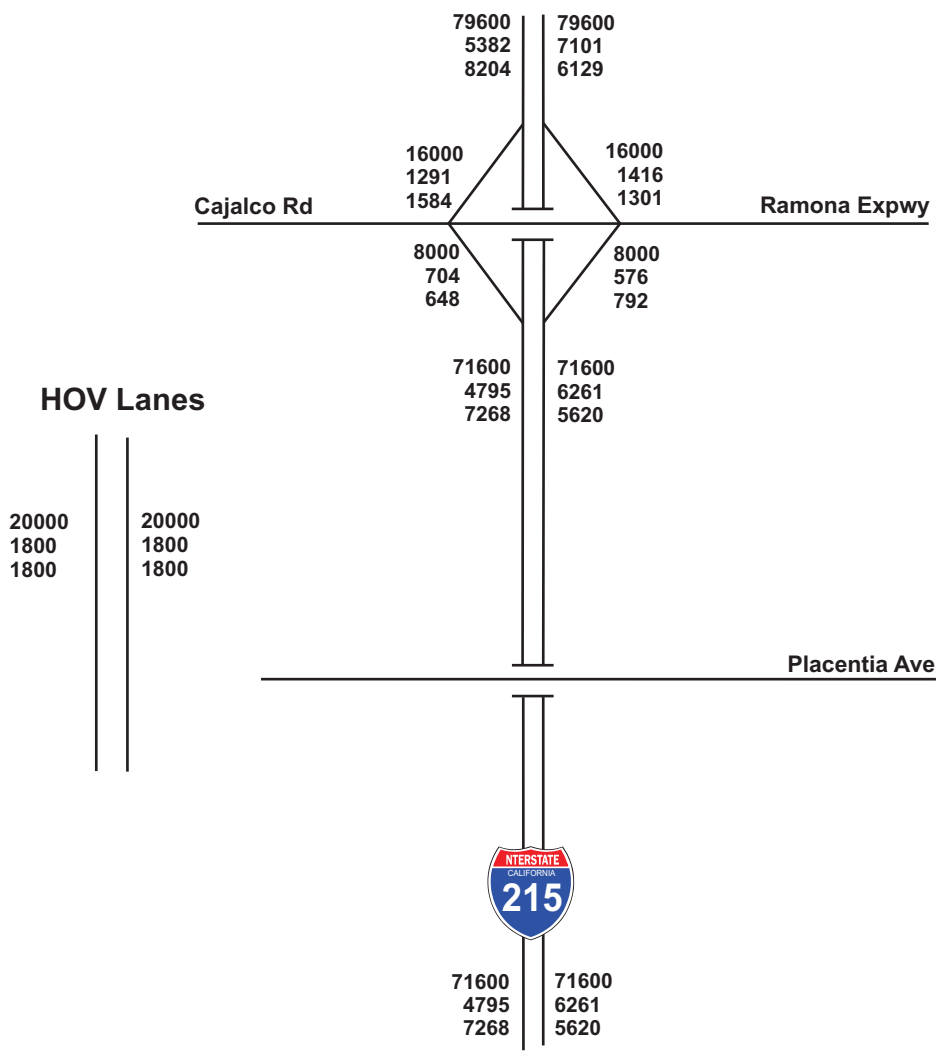

**Horizon Year (2040)
Freeway and Ramp Traffic
Interstate 215 - No Build**

Figure 7-4b

Legend

- XXXXX Average Daily Traffic
- XXX AM Peak Hour Traffic
- XXX PM Peak Hour Traffic



**HOV Lanes
(North of Nuevo Road Only)**

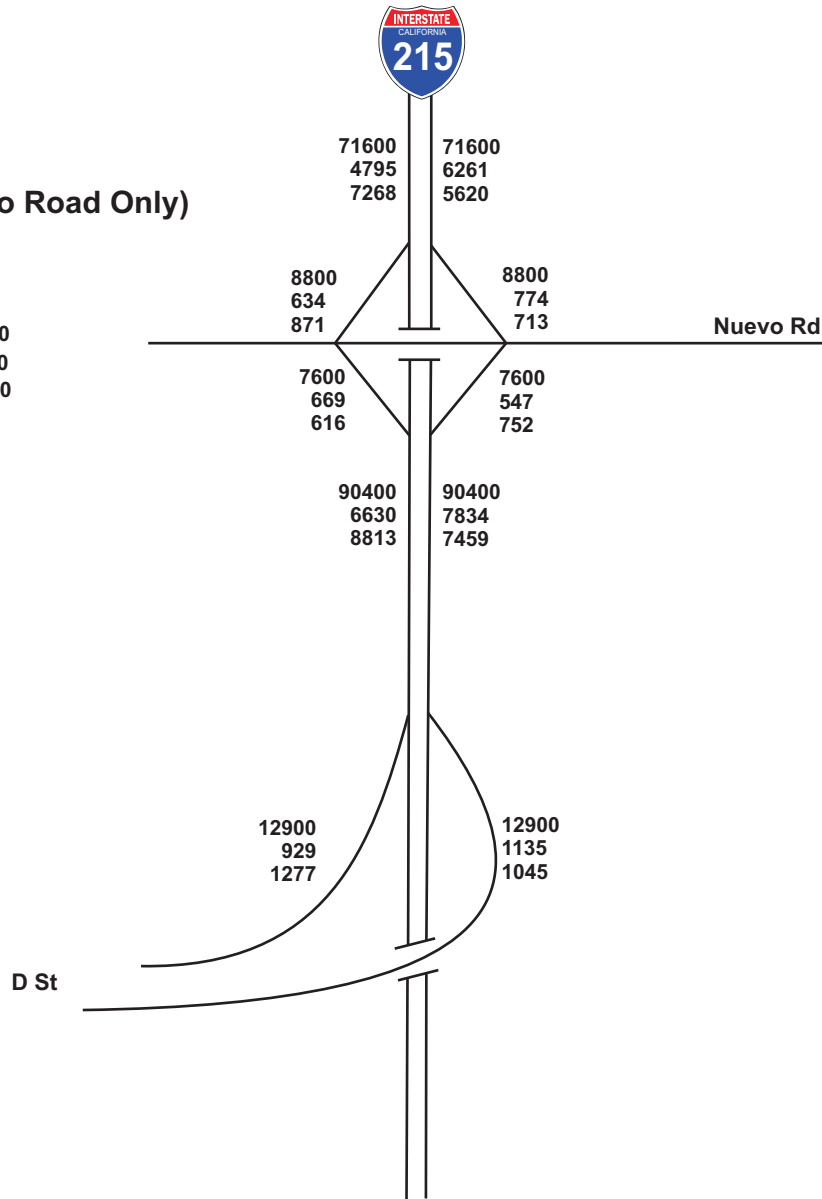
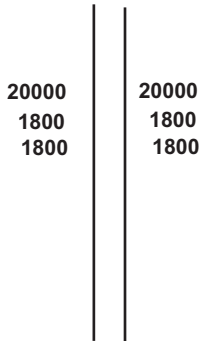

**Horizon Year (2040)
Freeway and Ramp Traffic
Interstate 215 - No Build**

Figure 7-4c

Legend

- XXXXXX Average Daily Traffic
- XXX AM Peak Hour Traffic
- XXX PM Peak Hour Traffic



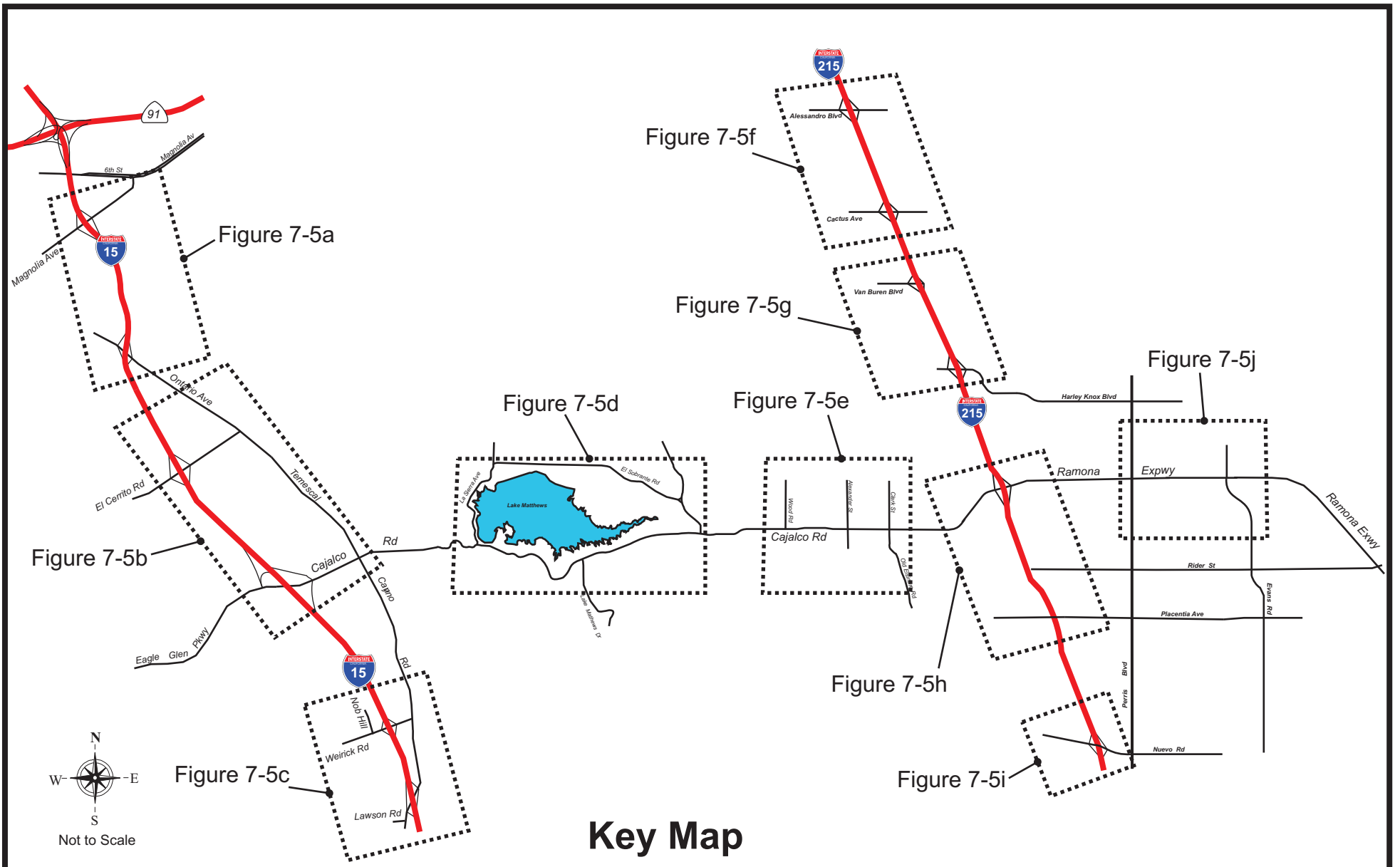

Horizon Year (2040) AM/PM Peak Hour Traffic - Intersections - No Build

Figure 7-5

Legend:

 **Figure Areas**



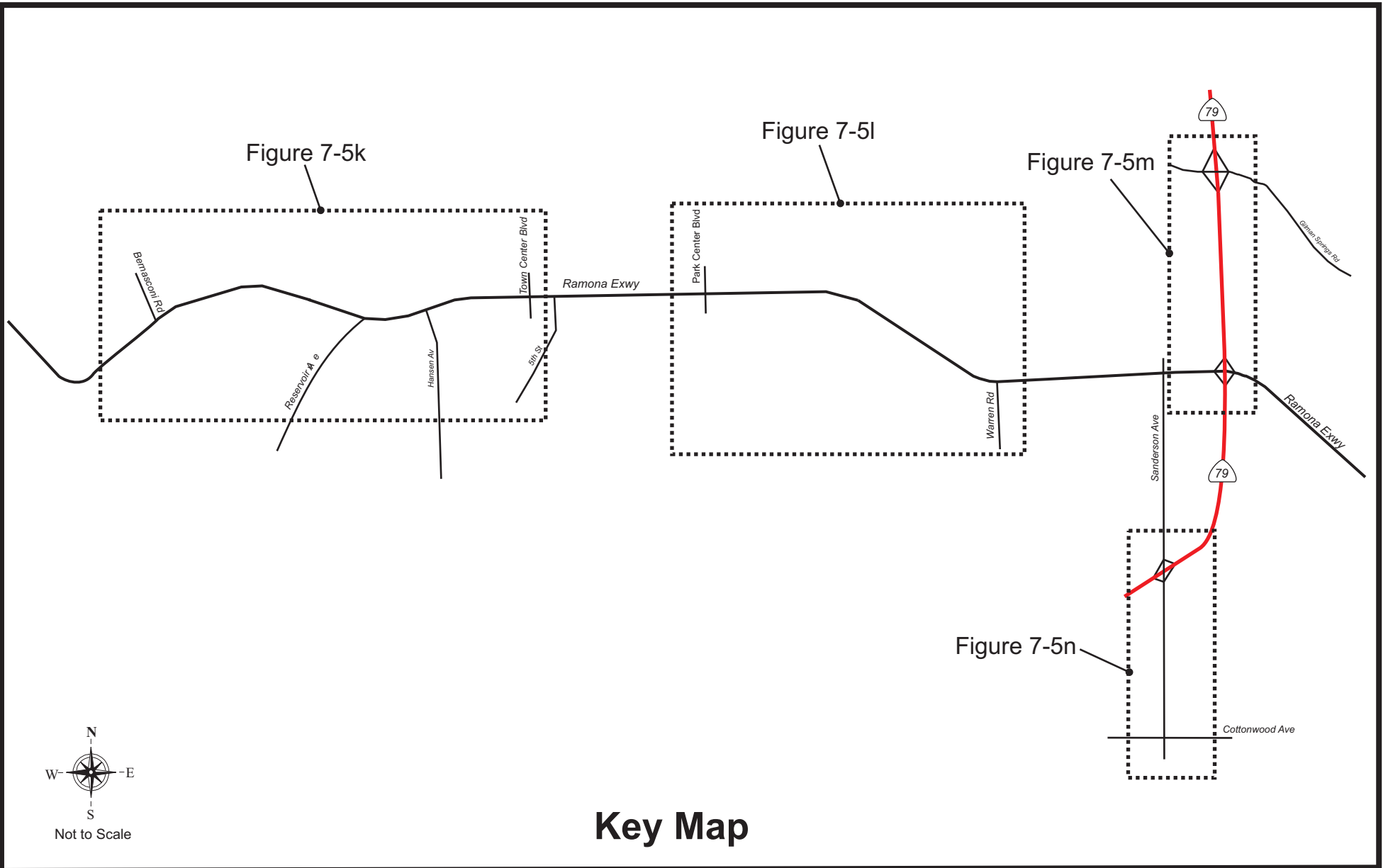

Key Map

Horizon Year (2040) AM/PM Peak Hour Traffic - Intersections - No Build

Figure 7-5 (cont.)

Legend:

 **Figure Areas**



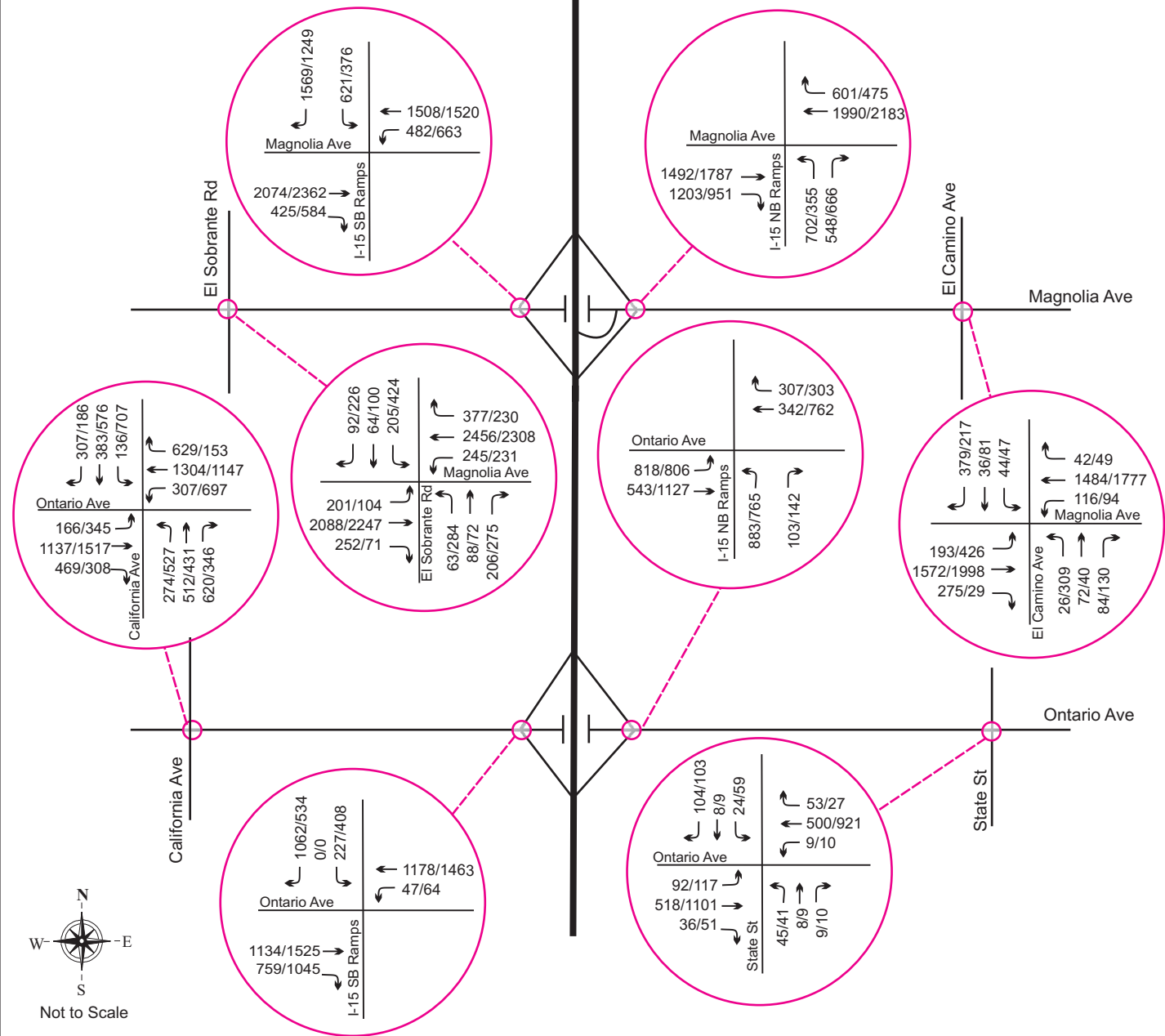

Horizon Year (2040) AM/PM Peak Hour Traffic Intersections - No Build

Figure 7-5a

XXX/XXX AM/PM Peak Hour



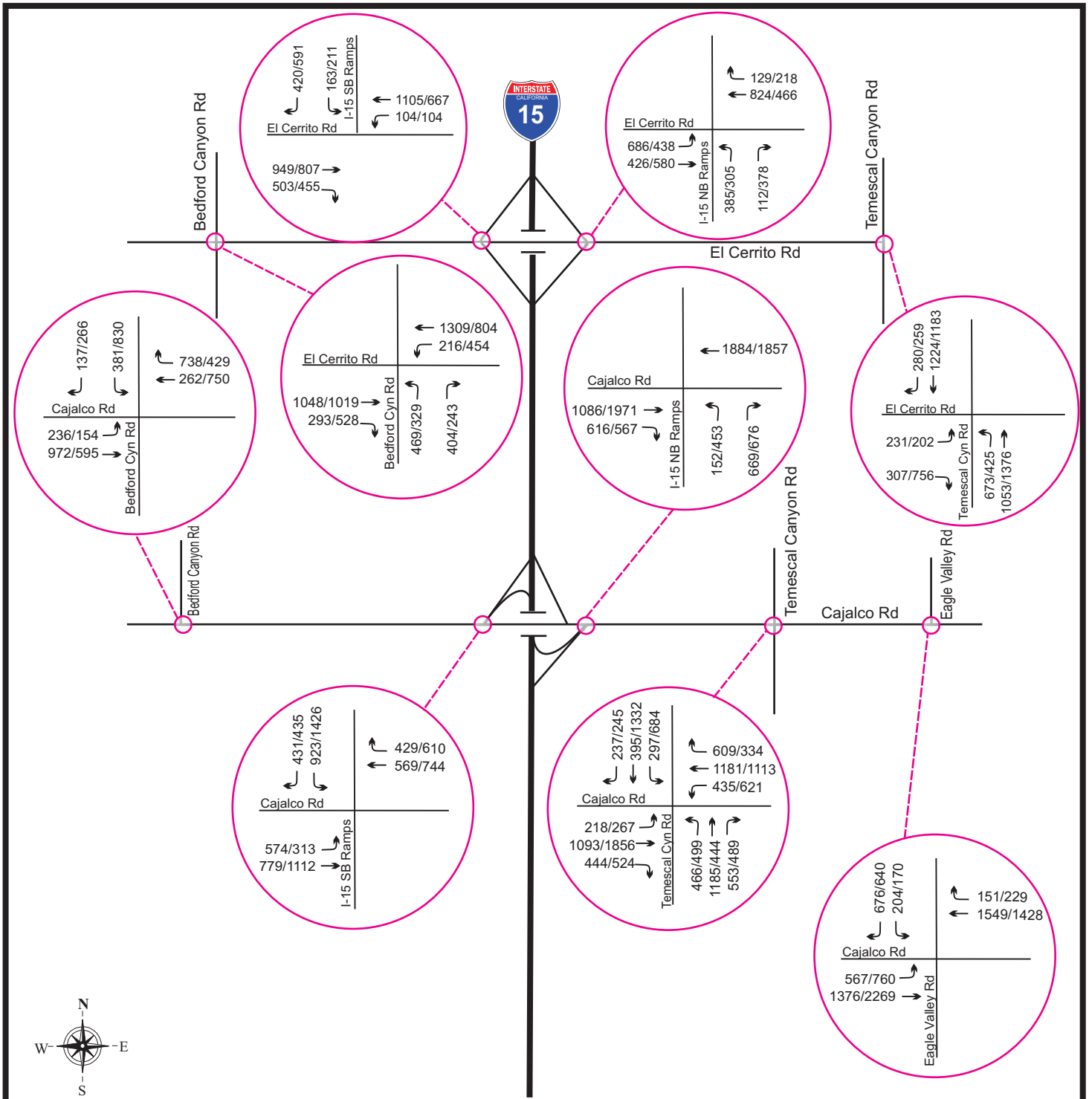

Horizon Year (2040) AM/PM Peak Hour Traffic Intersections - No Build

Figure 7-5b

XXX/XXX AM/PM Peak Hour



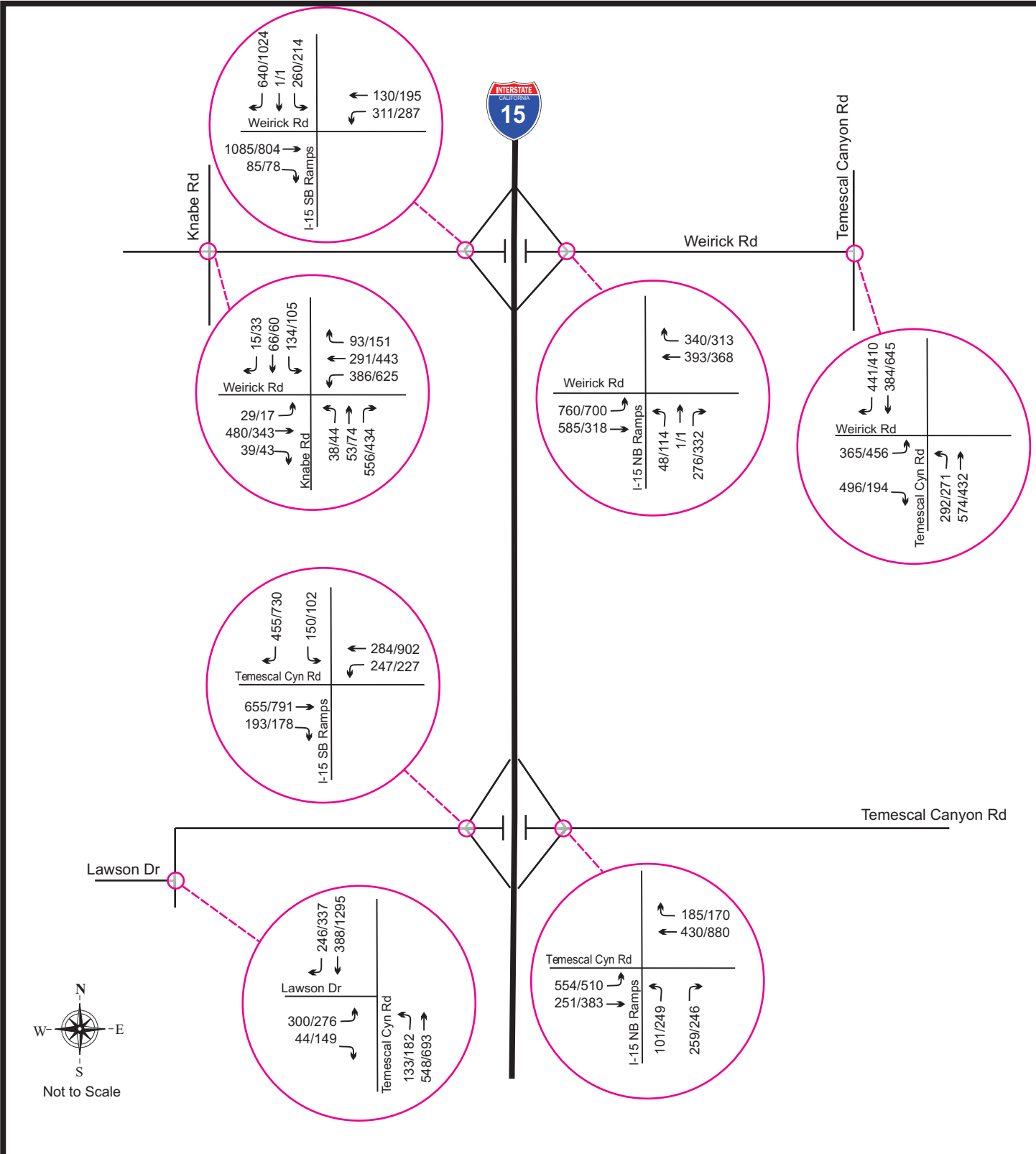

Horizon Year (2040) AM/PM Peak Hour Traffic Intersections - No Build

Figure 7-5c

XXX/XXX AM/PM Peak Hour



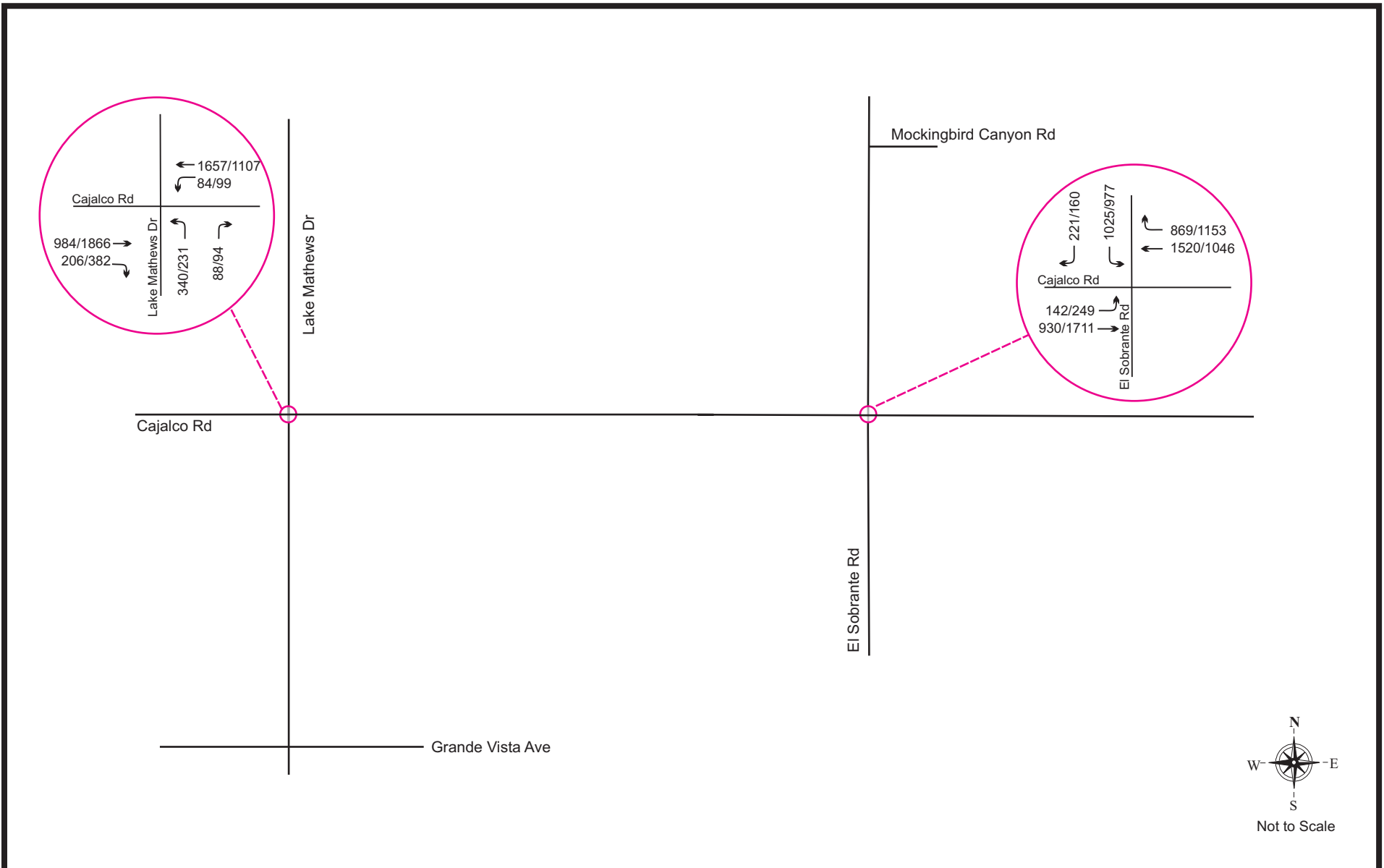

**Horizon Year (2040) AM/PM Peak Hour Traffic Intersections
No Build**

Figure 7-5d

XXX/XXX AM/PM Peak Hour



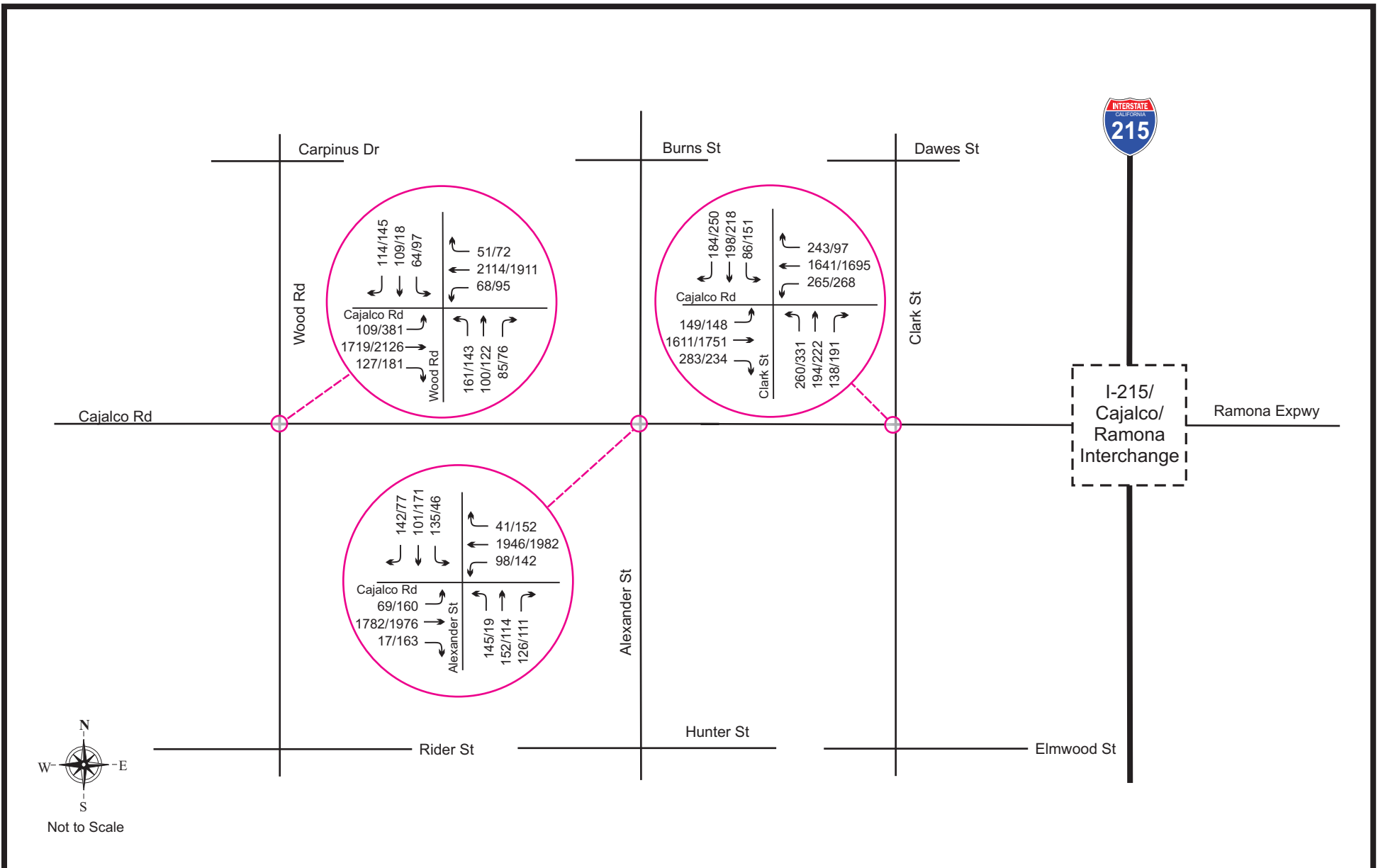

Horizon Year (2040) AM/PM Peak Hour Traffic Intersections No Build

Figure 7-5e

XXX/XXX AM/PM Peak Hour



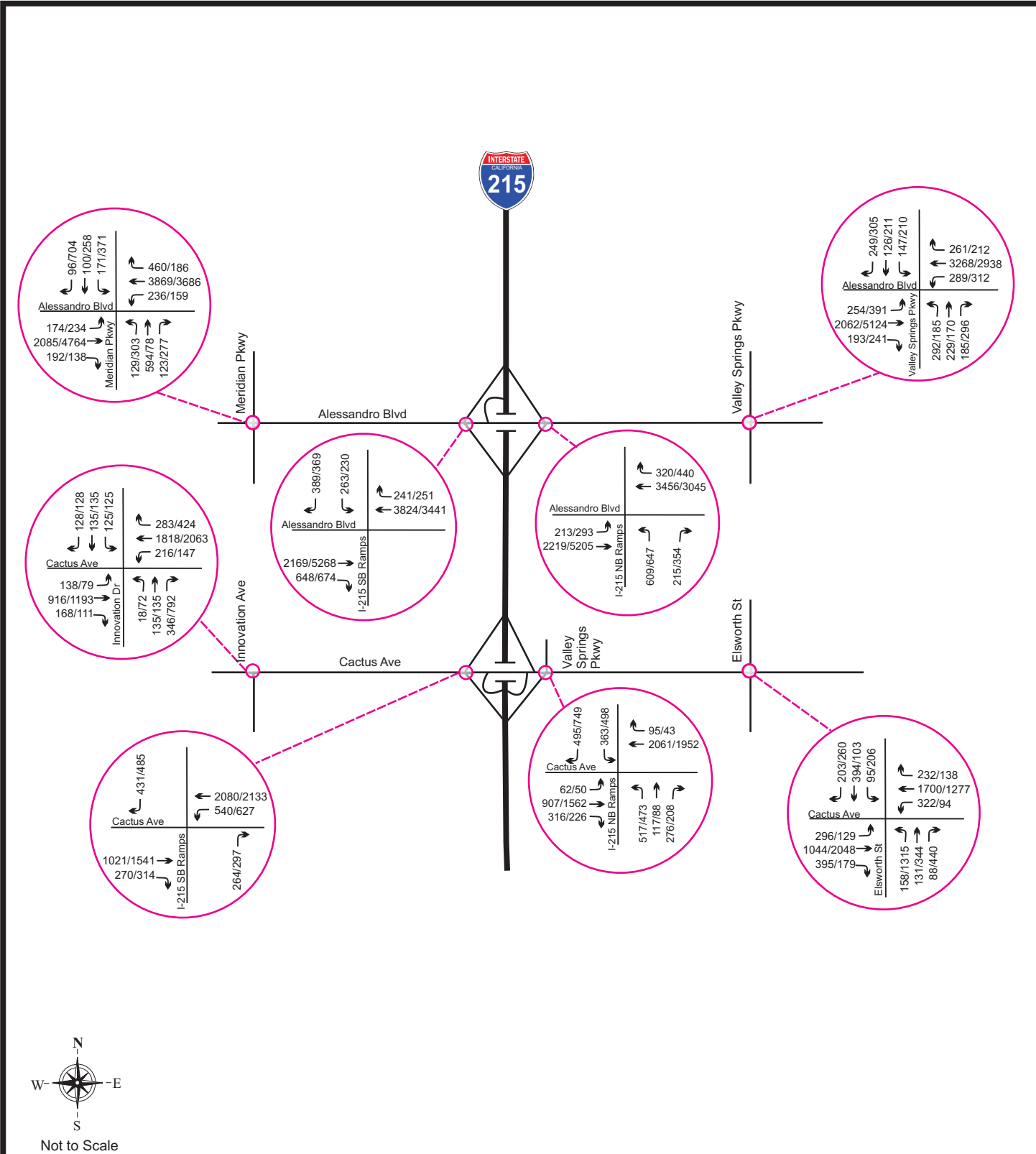

Horizon Year (2040) AM/PM Peak Hour Traffic Intersections - No Build

Figure 7-5f

XXX/XXX AM/PM Peak Hour



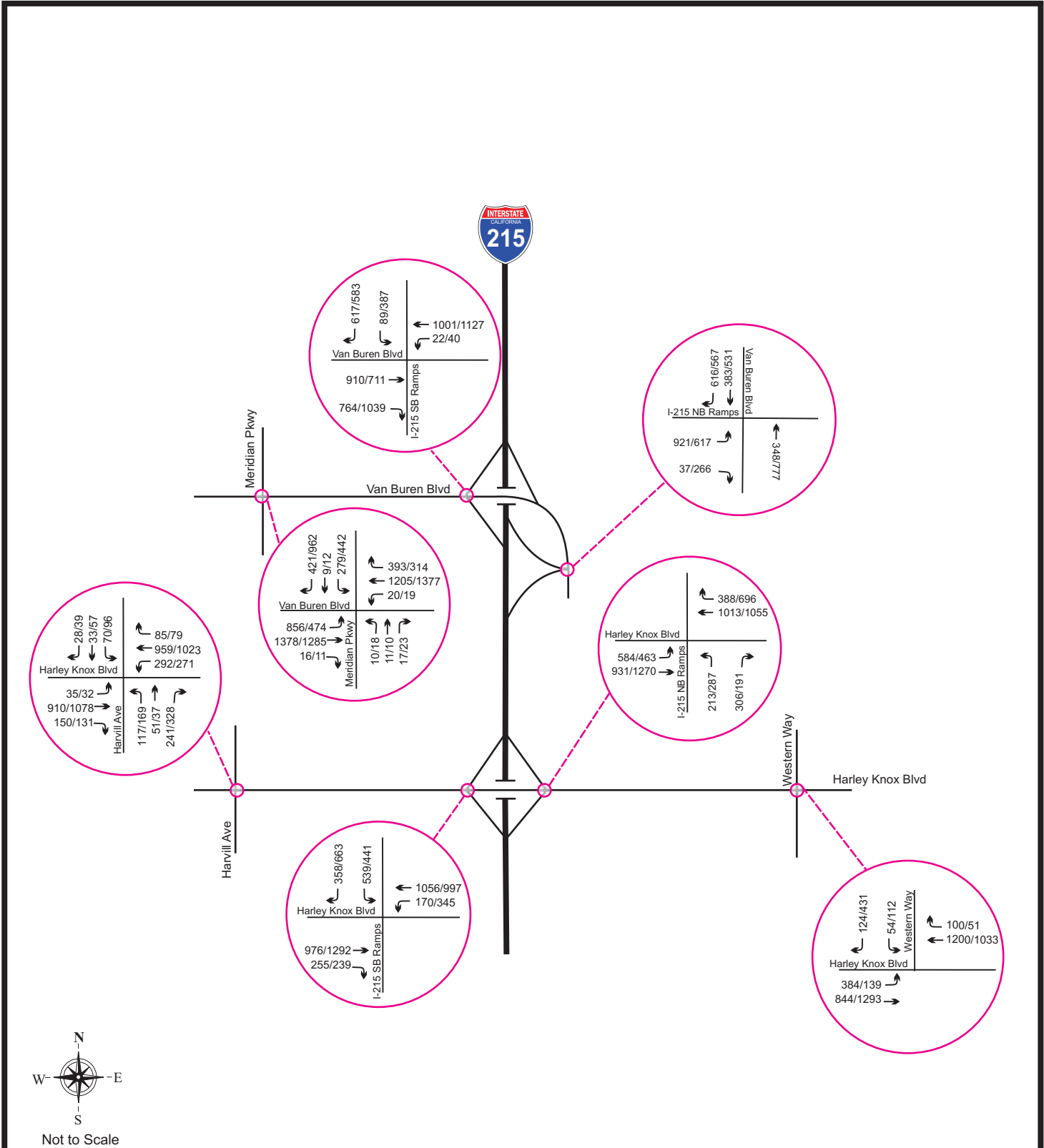

Horizon Year (2040) AM/PM Peak Hour Traffic Intersections - No Build

Figure 7-5g

XXX/XXX AM/PM Peak Hour



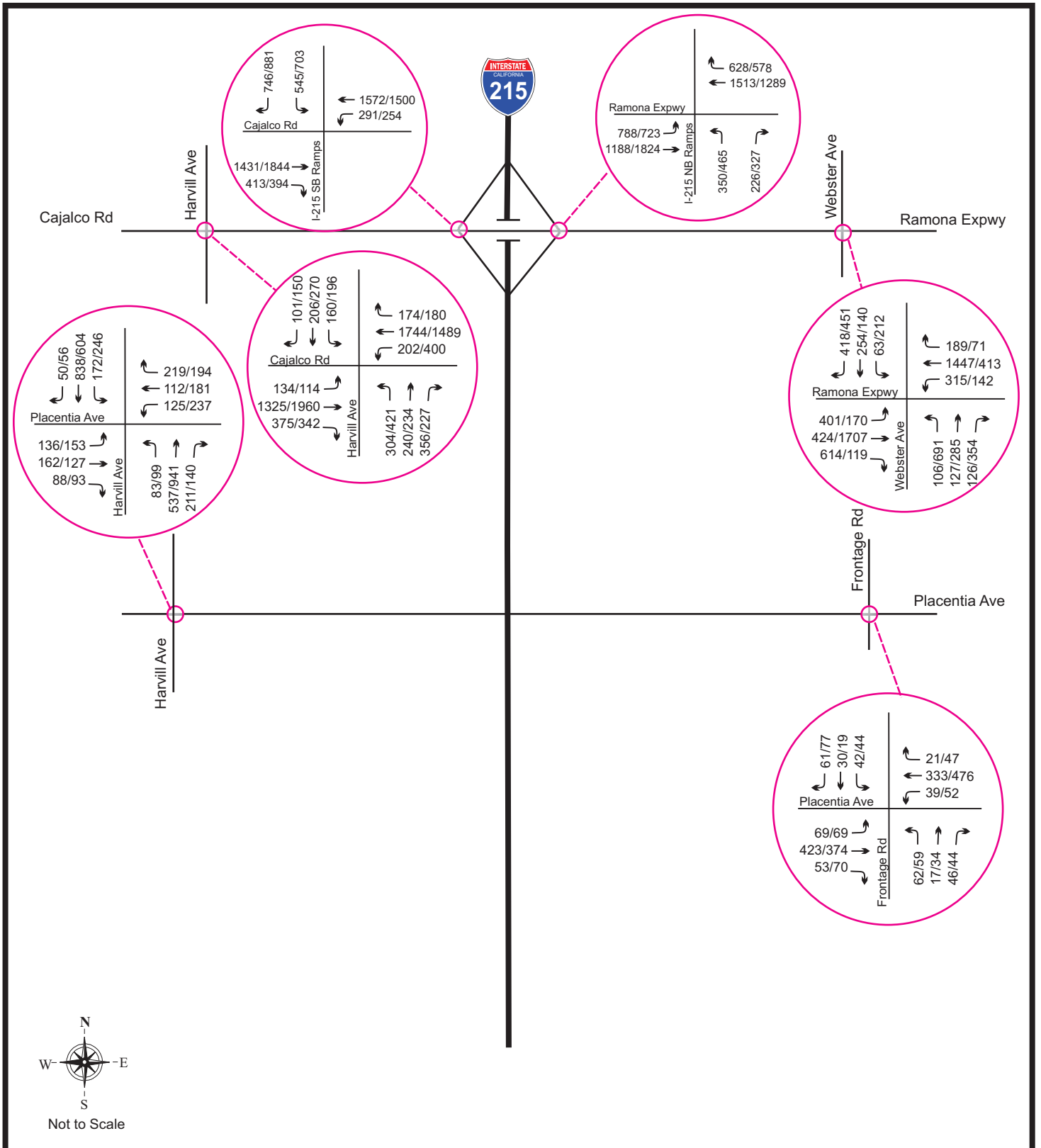

Horizon Year (2040) AM/PM Peak Hour Traffic Intersections - No Build

Figure 7-5h

XXX/XXX AM/PM Peak Hour



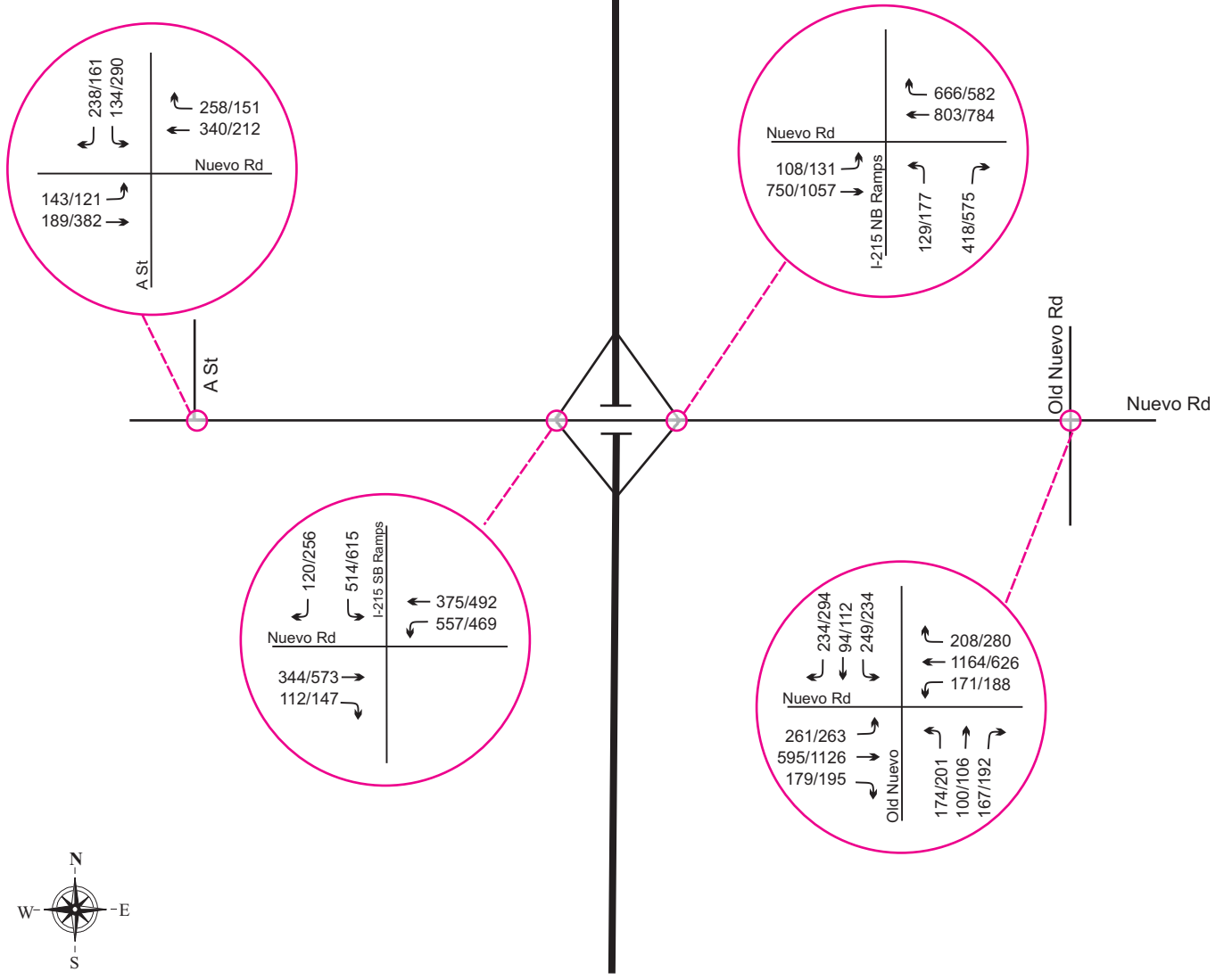

Horizon Year (2040) AM/PM Peak Hour Traffic Intersections - No Build

Figure 7-5i

XXX/XXX AM/PM Peak Hour



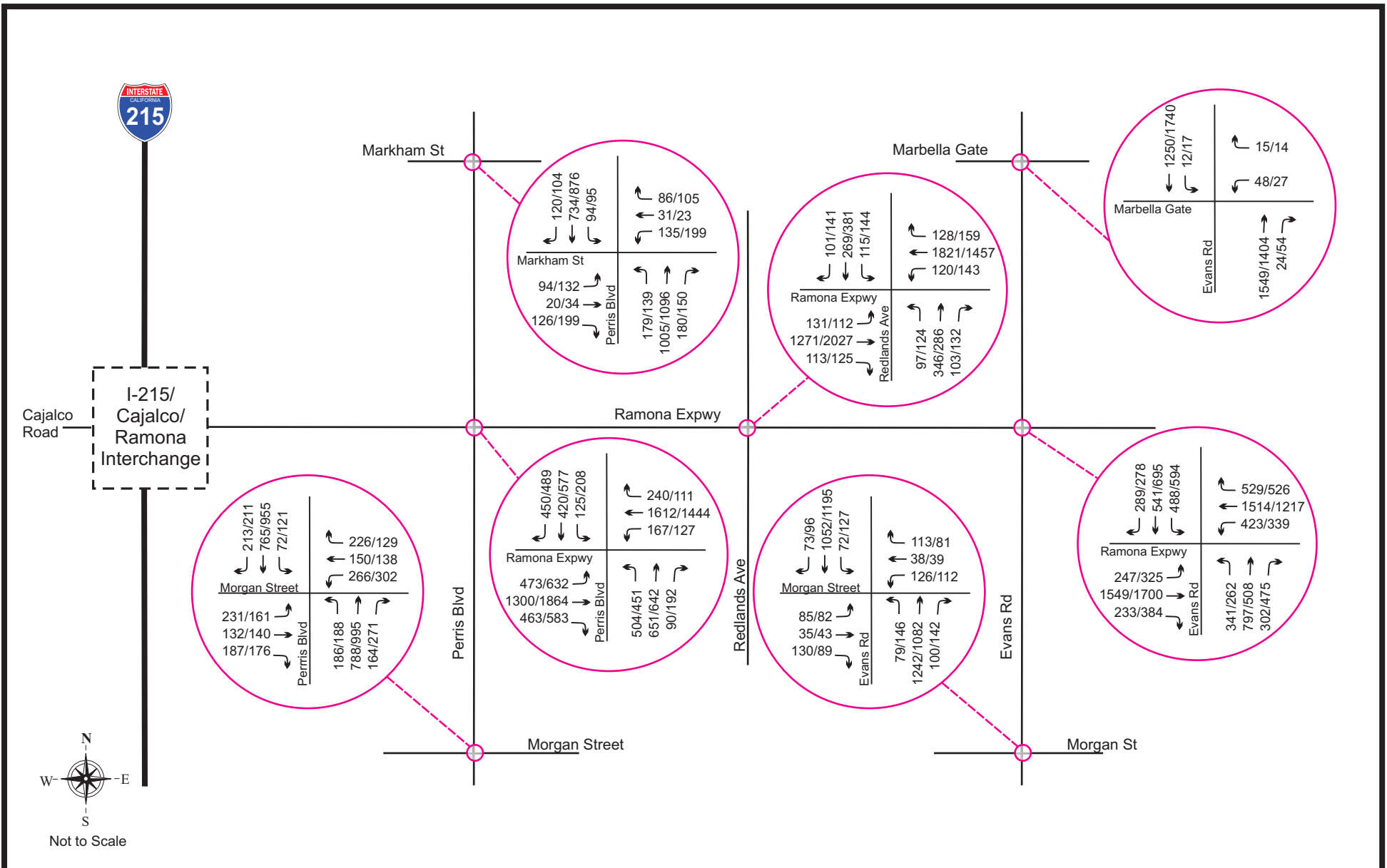

**Horizon Year (2040) AM/PM Peak Hour Traffic Intersections
No Build**

Figure 7-5j

XXX/XXX AM/PM Peak Hour



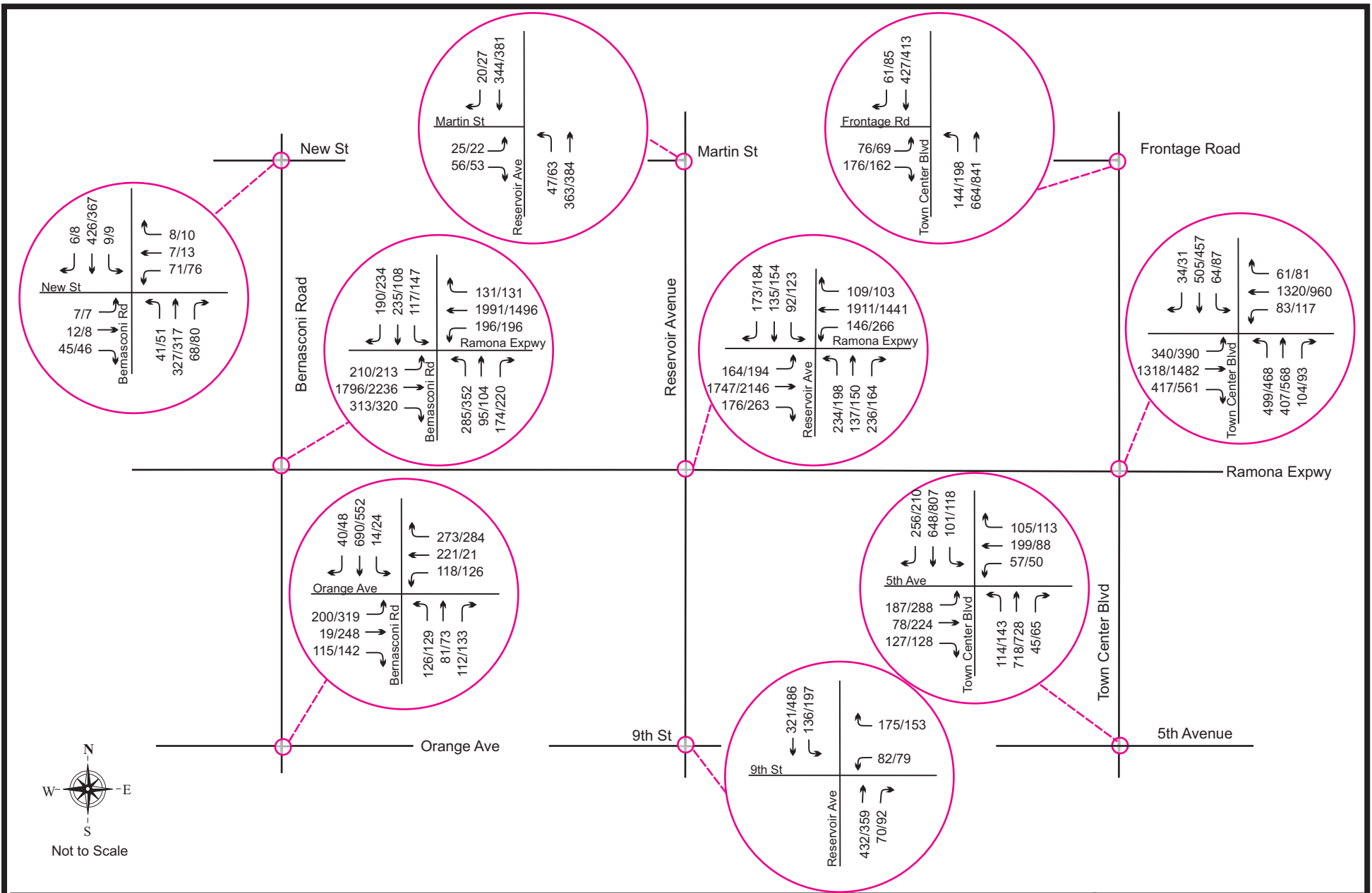

Horizon Year (2040) AM/PM Peak Hour Traffic Intersections - No Build

Figure 7-5k

XXX/XXX AM/PM



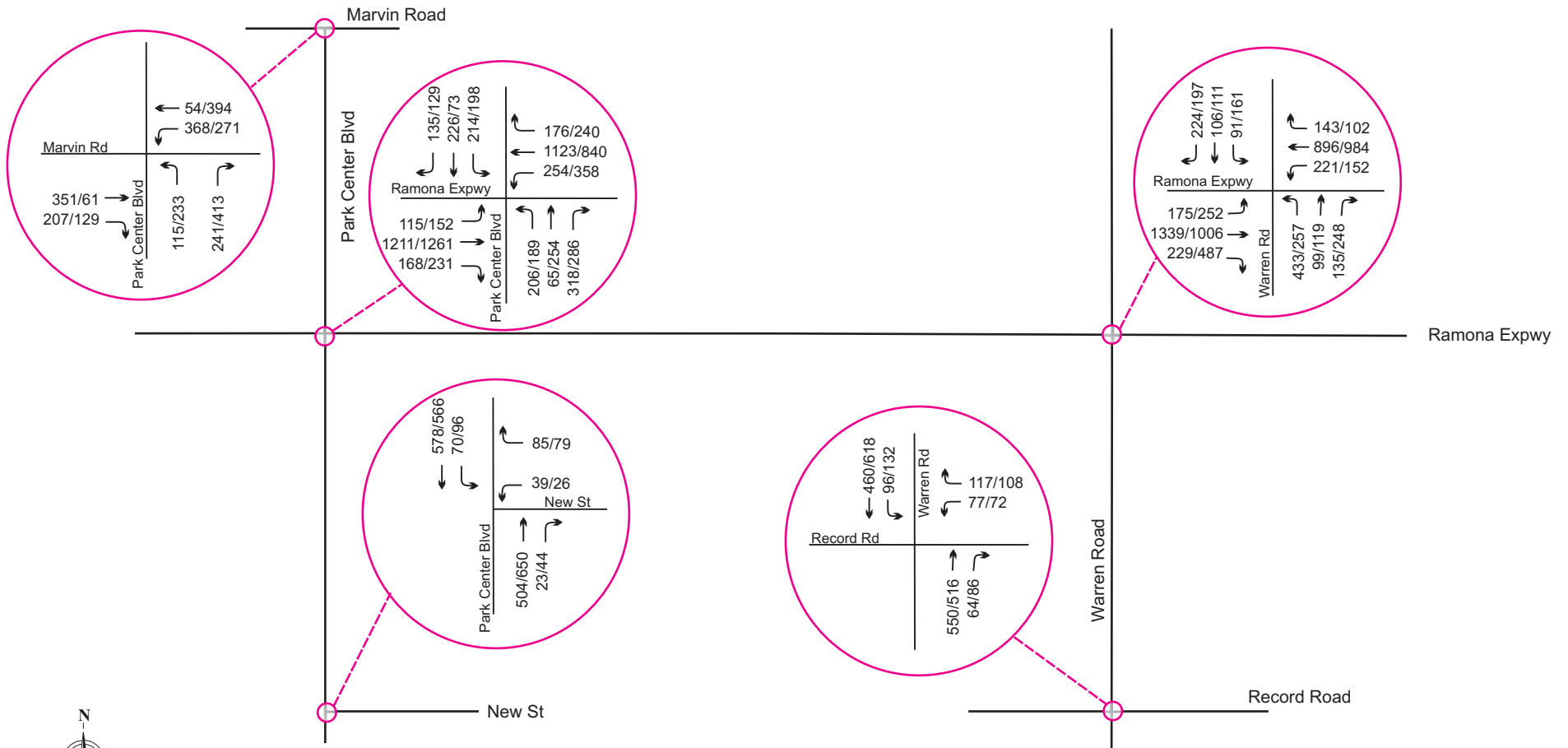

**Horizon Year (2040) AM/PM Peak Hour Traffic Intersections
No Build**

Figure 7-5I

XXX/XXX AM/PM Peak Hour



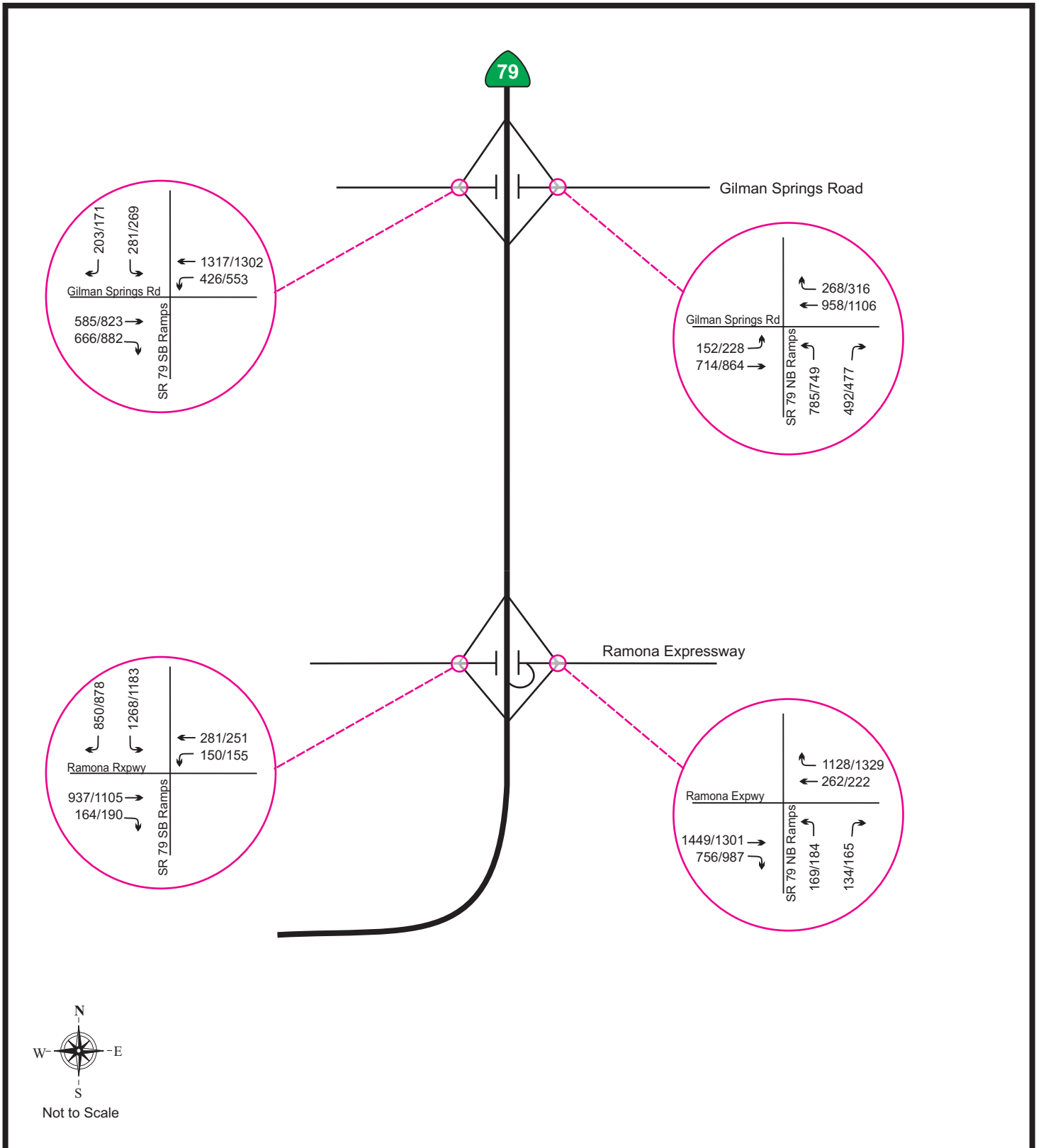

Horizon Year (2040) AM/PM Peak Hour Traffic Intersections - No Build

Figure 7-5m

XXX/XXX AM/PM Peak Hour



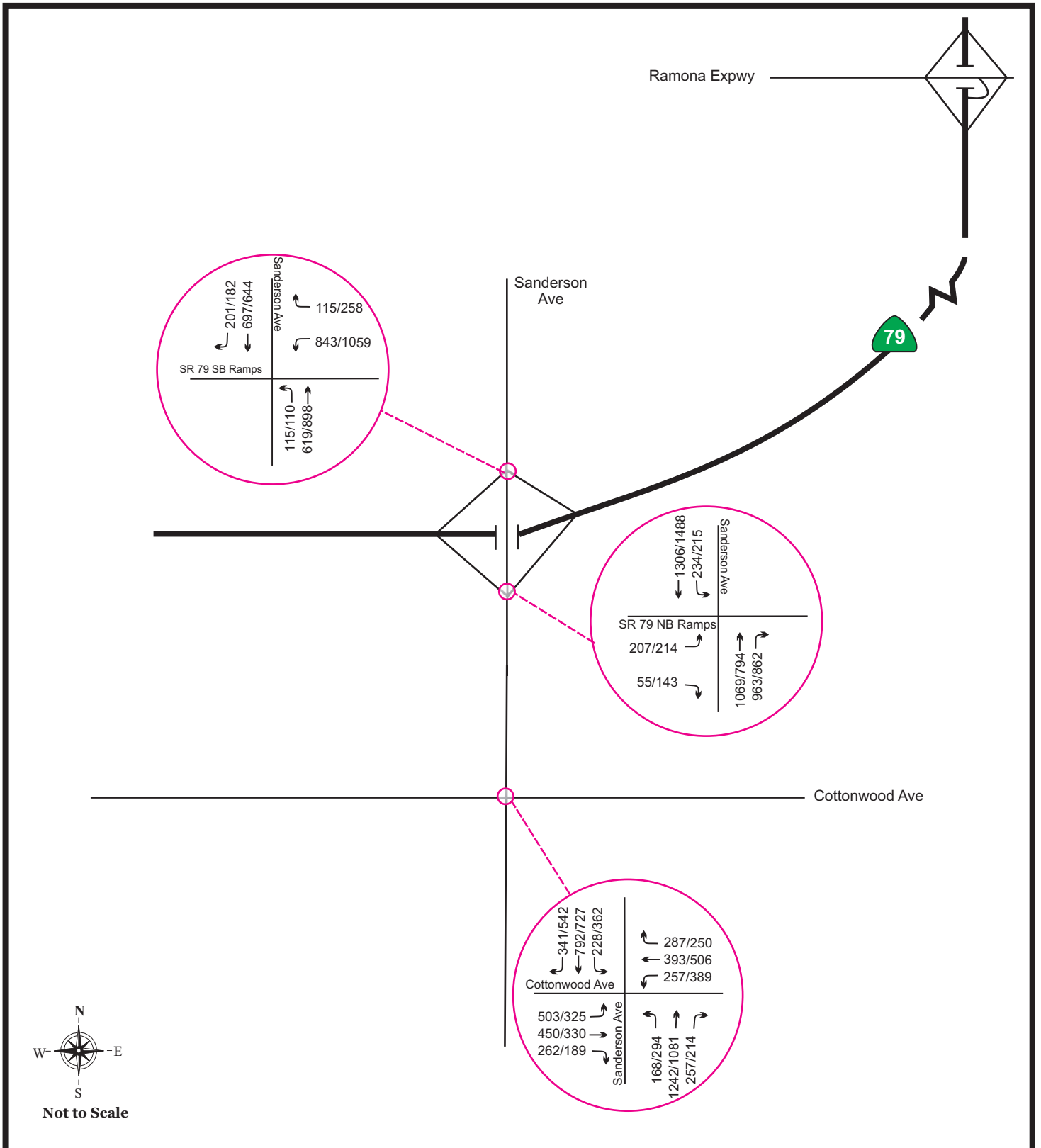

Horizon Year (2040) AM/PM Peak Hour Traffic Intersections - No Build

Figure 7-5n

XXX/XXX AM/PM Peak Hour



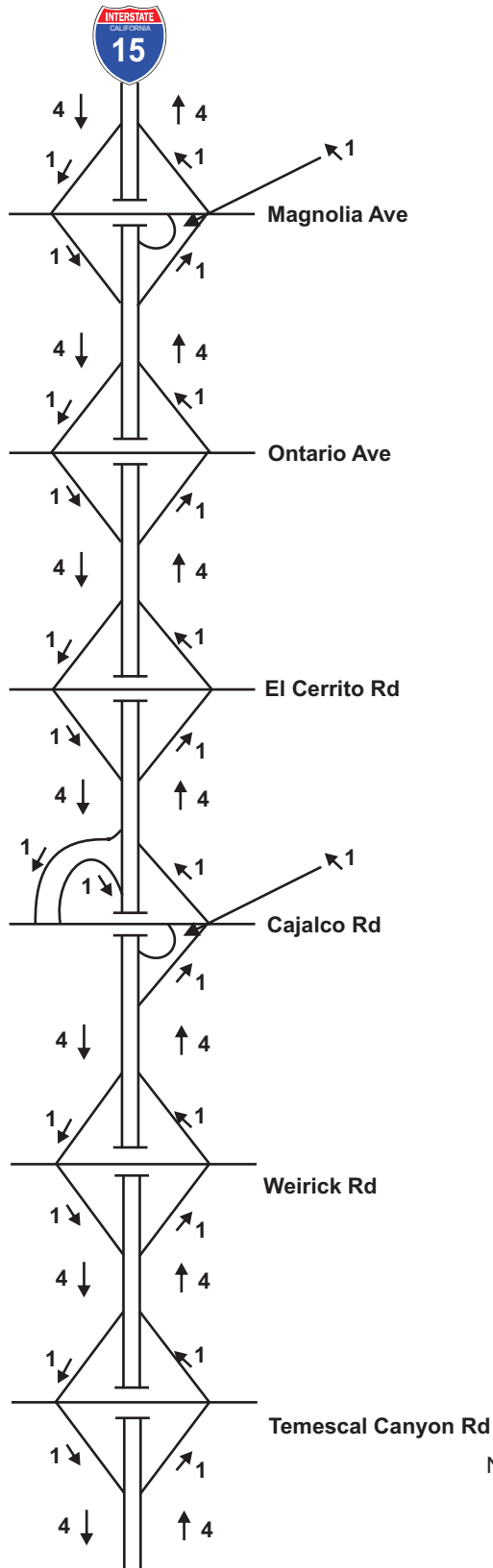

Note:
Two Express Lanes
in each direction of travel
will be provided in addition to
the lanes indicated on I-15.

Horizon Year (2040) Freeway Mainline Lane Geometry Interstate 15 - No Build

Figure 7-6

Legend

- Direction of Travel
- X : Number of Lanes (Mixed Flow)



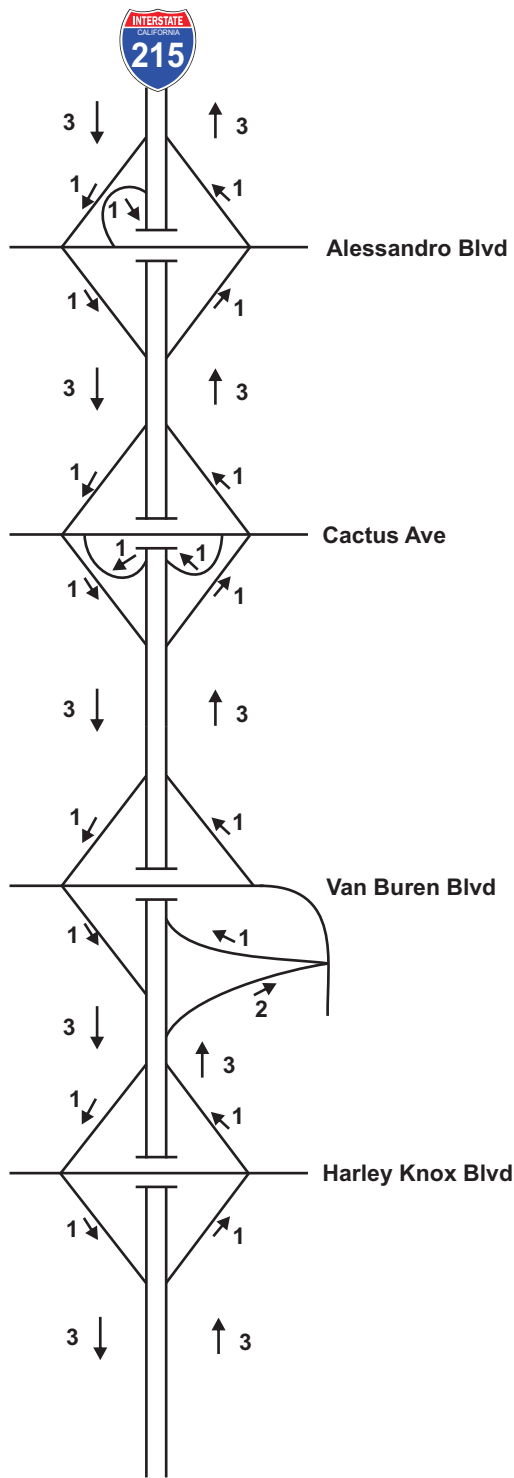

Note:
 One HOV Lane in each direction of travel will be provided in addition to the lanes indicated on I-215.

**Horizon Year (2040)
 Freeway Mainline Lane Geometry
 Interstate 215 - No Build**

Figure 7-7a

Legend
 → Direction of Travel
 X : Number of Lanes (Mixed Flow)



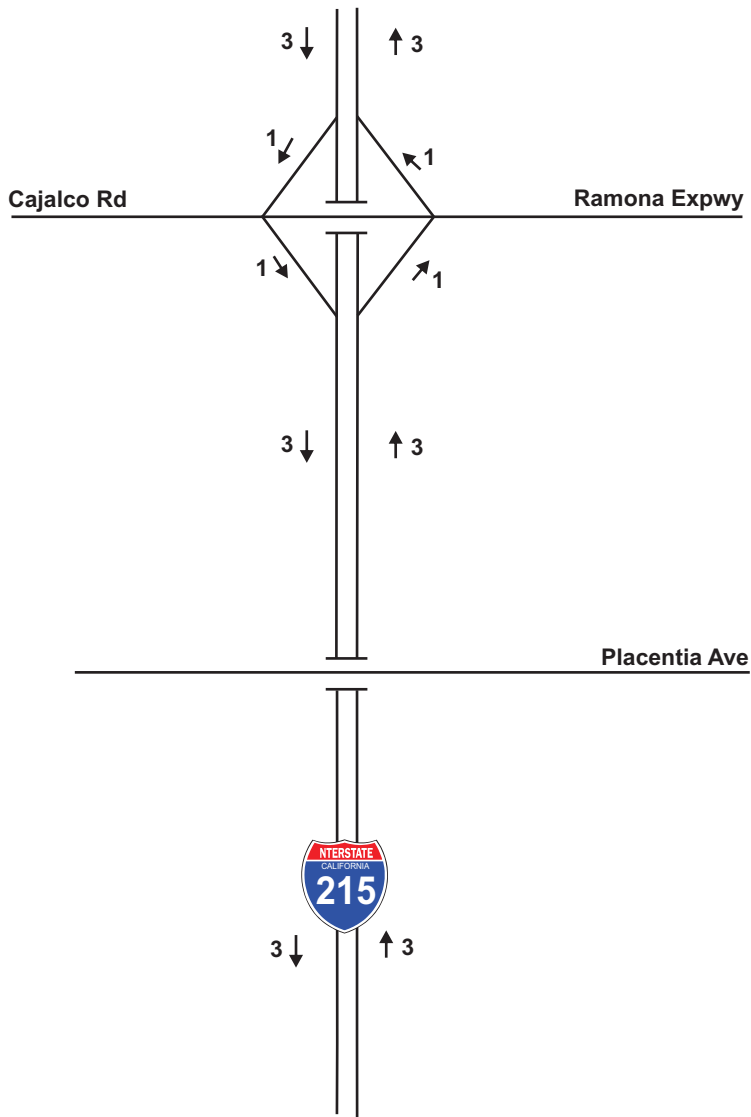

Note:
 One HOV Lane in each direction of travel will be provided in addition to the lanes indicated on I-215.

**Horizon Year (2040)
 Freeway Mainline Lane Geometry
 Interstate 215 - No Build**

Figure 7-7b

Legend
 → Direction of Travel
 X : Number of Lanes (Mixed Flow)



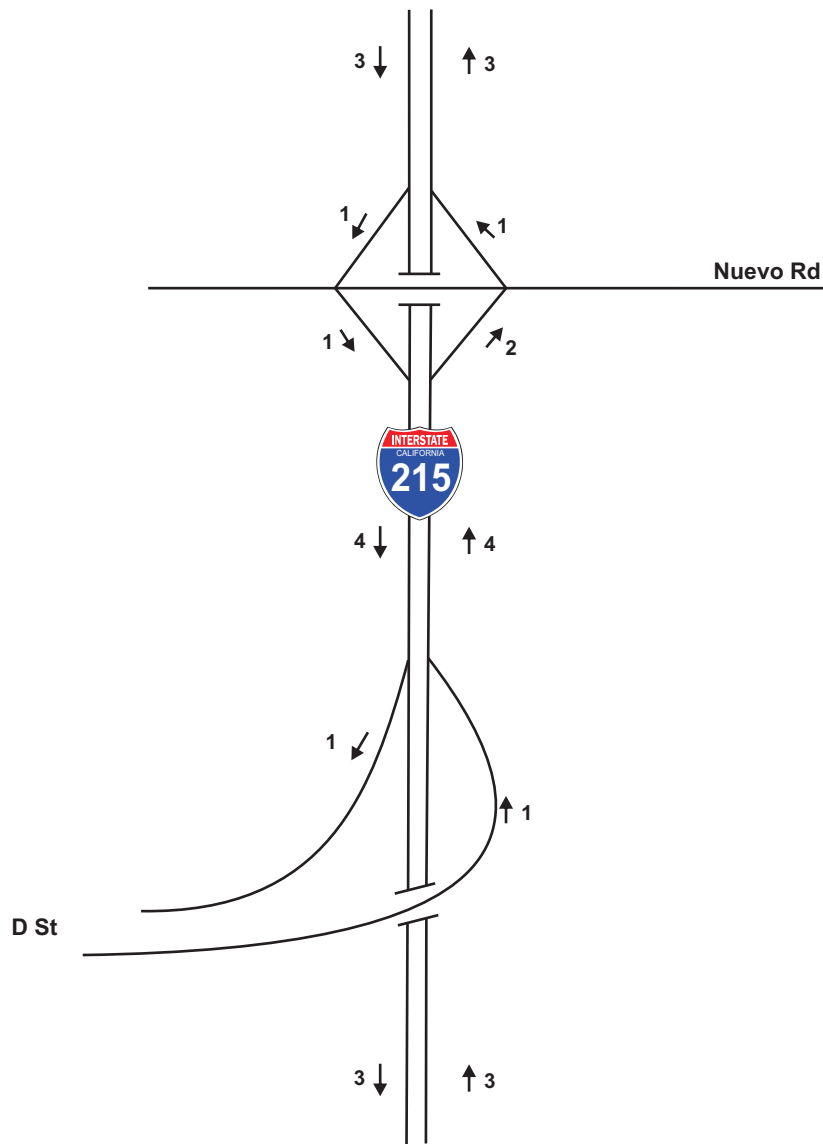

Note:
 One HOV Lane in each direction of travel will be provided North of Nuevo Road in addition to the lanes indicated on I-215.

**Horizon Year (2040)
 Freeway Mainline Lane Geometry
 Interstate 215 - No Build**

Figure 7-7c

Legend
 → Direction of Travel
 X : Number of Lanes (Mixed Flow)



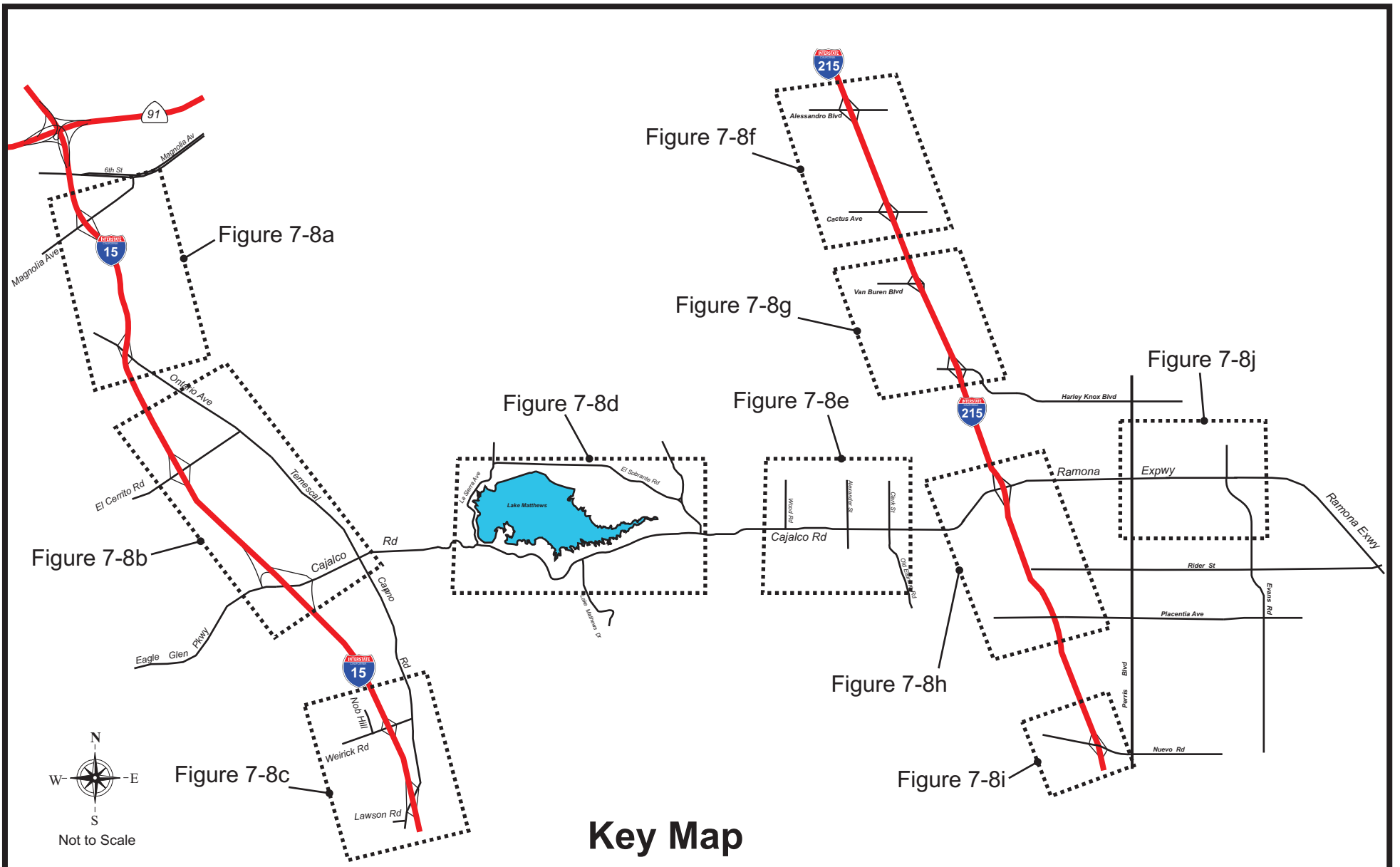

**Horizon Year (2040) Intersection Lane Geometry
No Build/Existing Conditions**

Figure 7-8



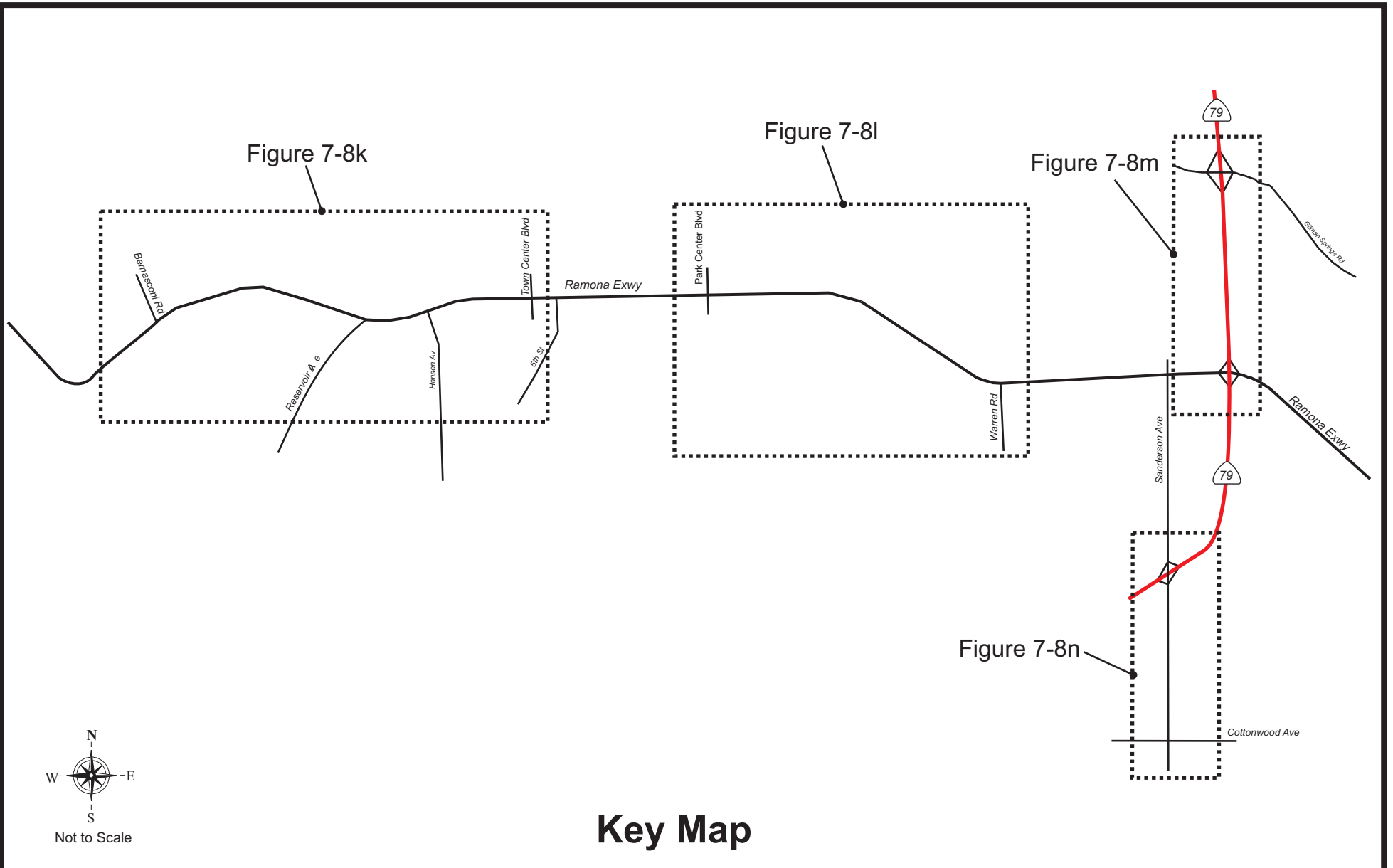

Key Map

**Horizon Year (2040) Intersection Lane Geometry
No Build/Existing Conditions**

Figure 7-8 (cont.)

Legend:

 Figure Areas



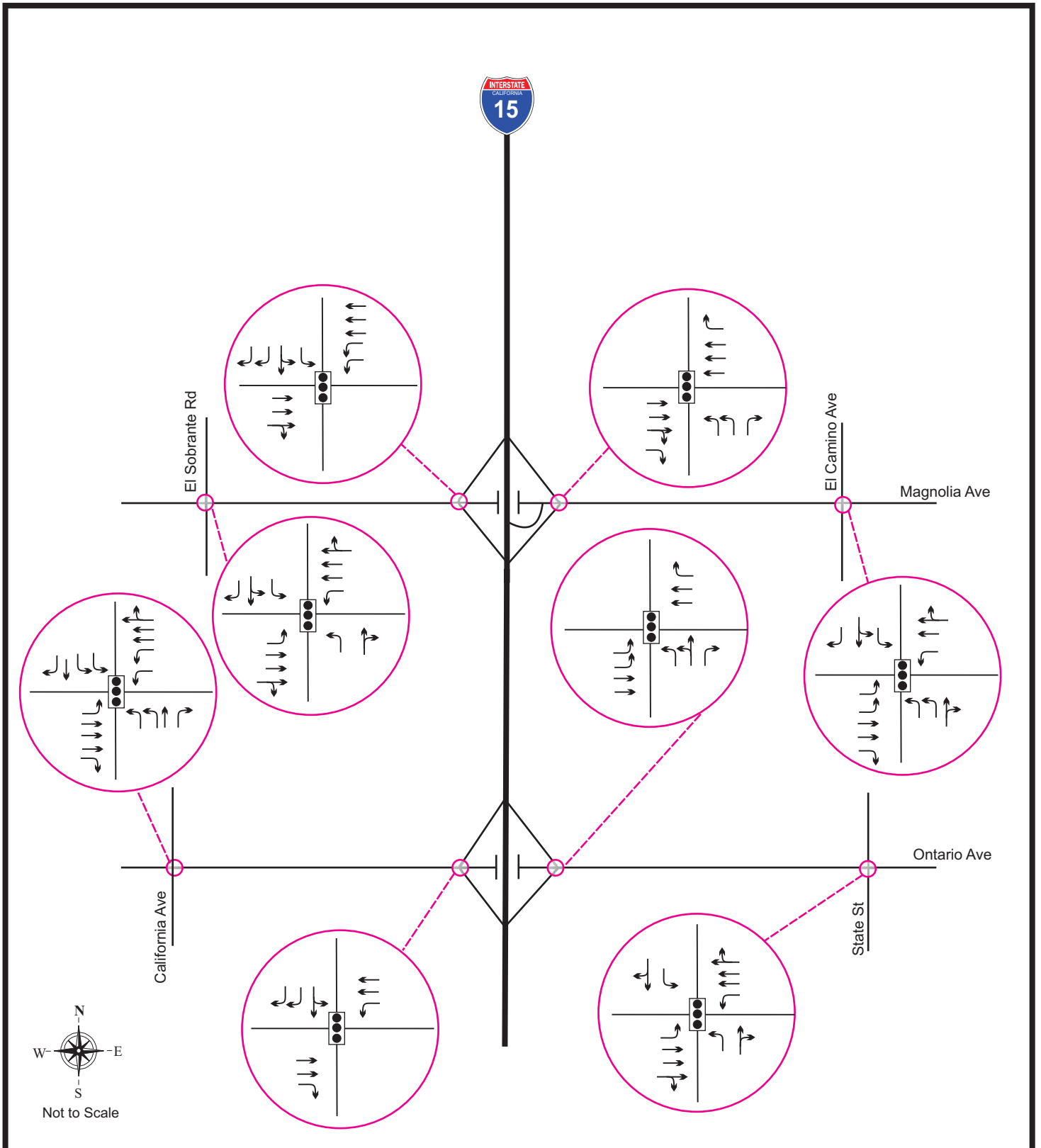

Horizon Year (2040) Intersection Lane Geometry - No Build/Existing Conditions

Figure 7-8a

Legend:



Signal



Traffic Lane



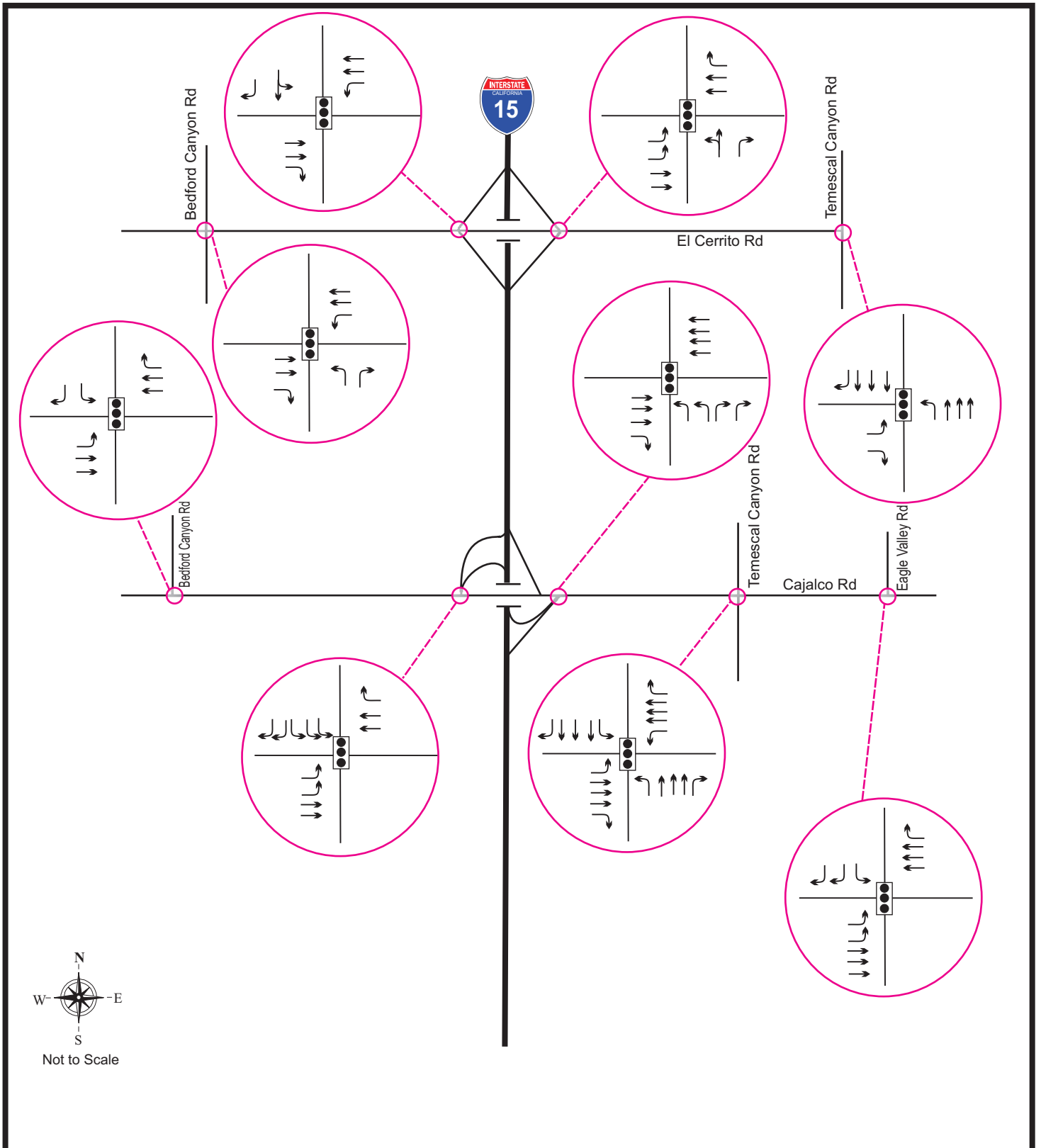

**Horizon Year (2040) Intersection
Lane Geometry - No Build/Existing Conditions**

Figure 7-8b

Legend:



Signal



Traffic Lane



VRPA TECHNOLOGIES, INC.

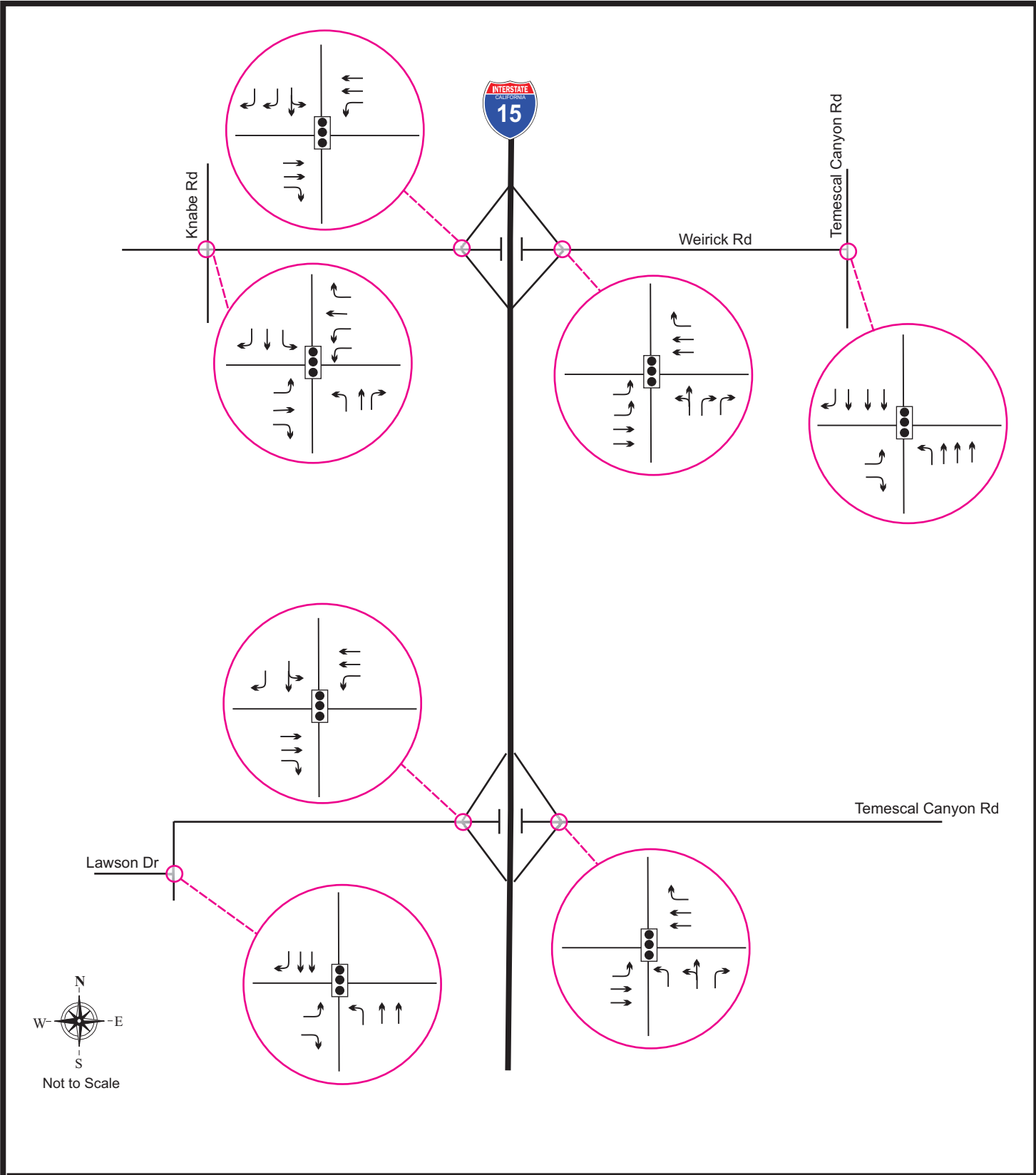

**Horizon Year (2040) Intersection
Lane Geometry - No Build/Existing Conditions**

Figure 7-8c

Legend:

-  Signal
-  Traffic Lane





**Horizon Year (2040) Intersection
Lane Geometry - No Build/Existing Conditions**

Figure 7-8d

Legend:

-  Signal
-  Traffic Lane



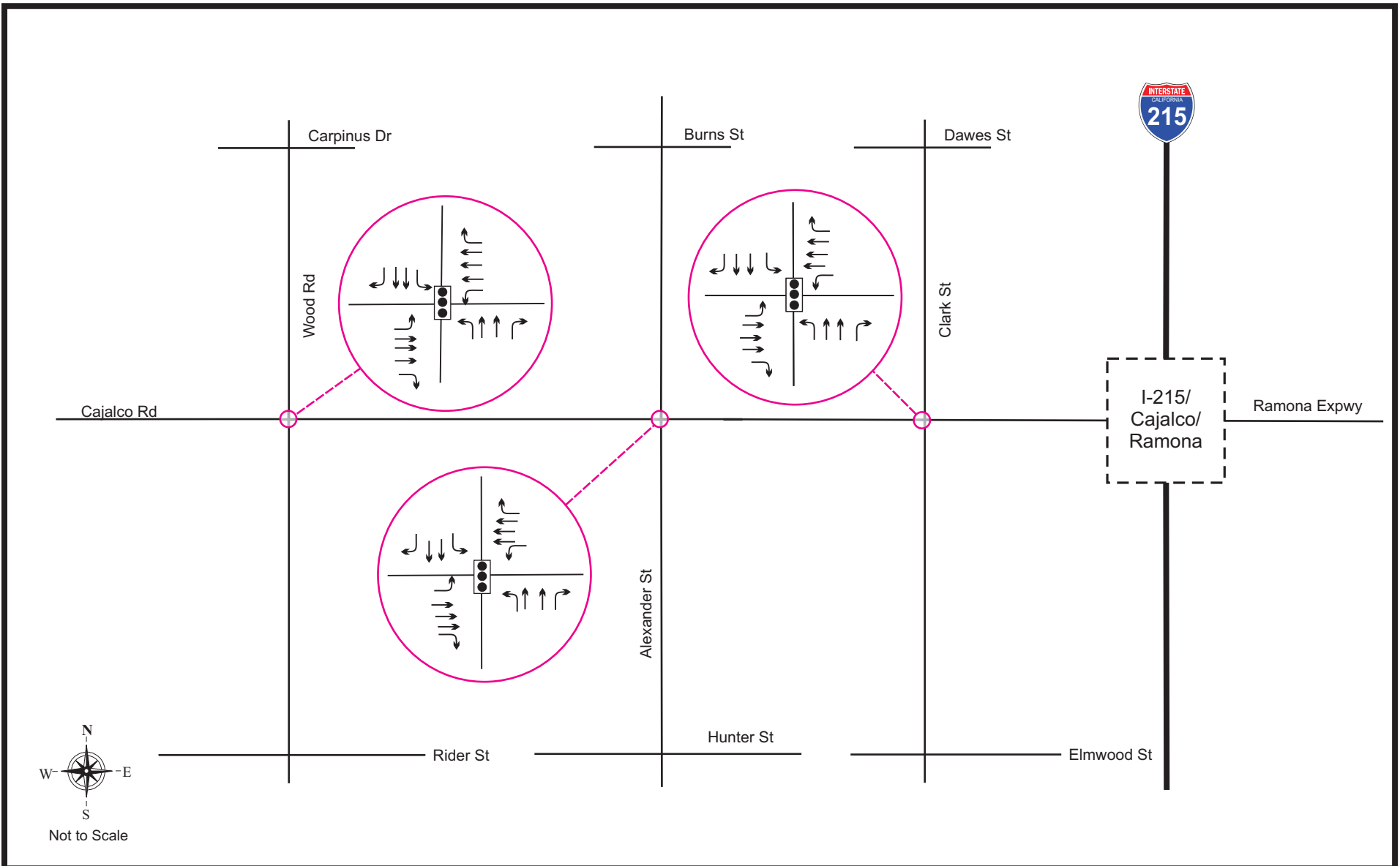

**Horizon Year (2040) Intersection
Lane Geometry - No Build/Existing Conditions**

Figure 7-8e

Legend:

-  Signal
-  Traffic Lane



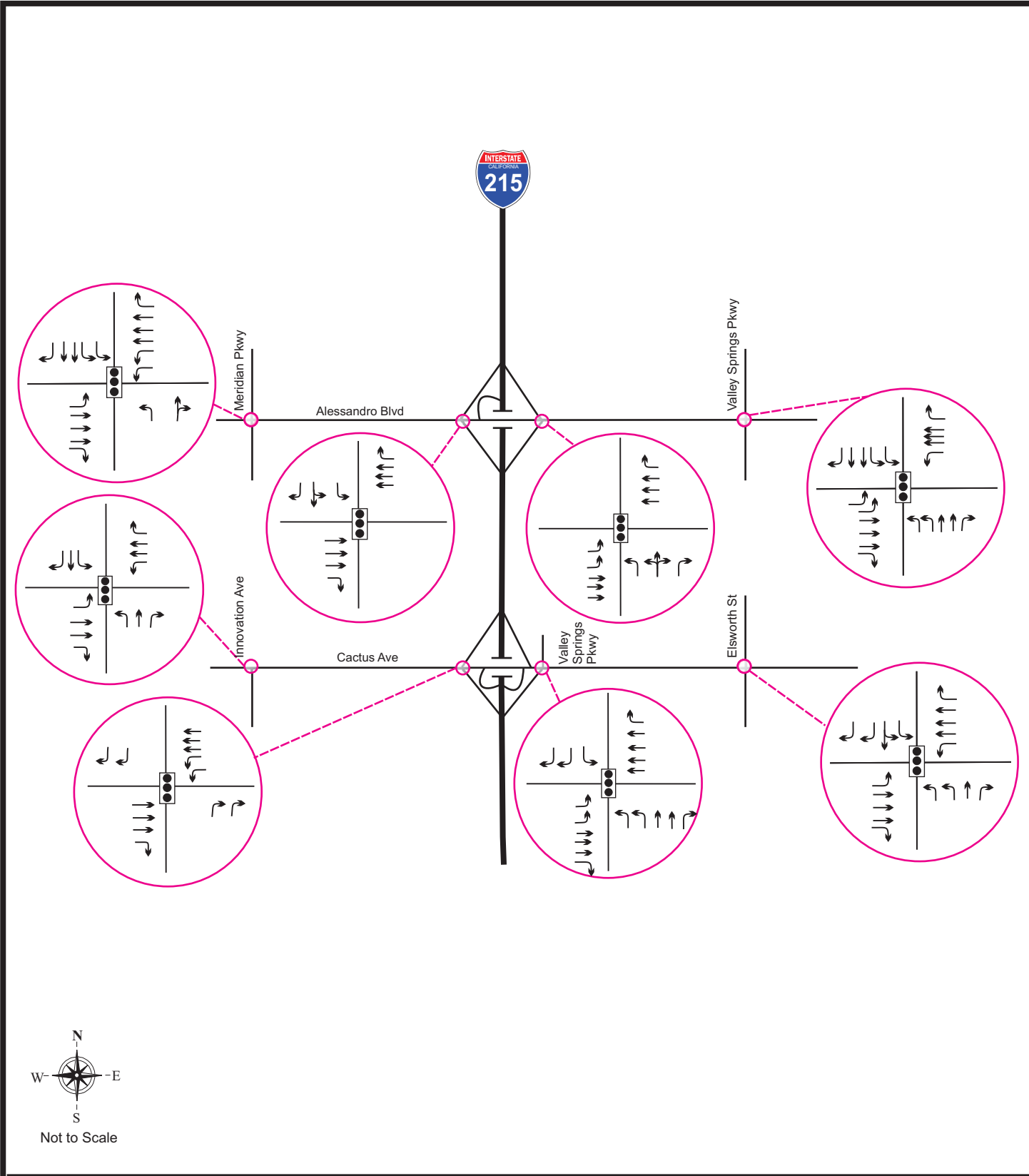

**Horizon Year (2040) Intersection
Lane Geometry - No Build/Existing Conditions**

Figure 7-8f

Legend:

-  Signal
-  Traffic Lane



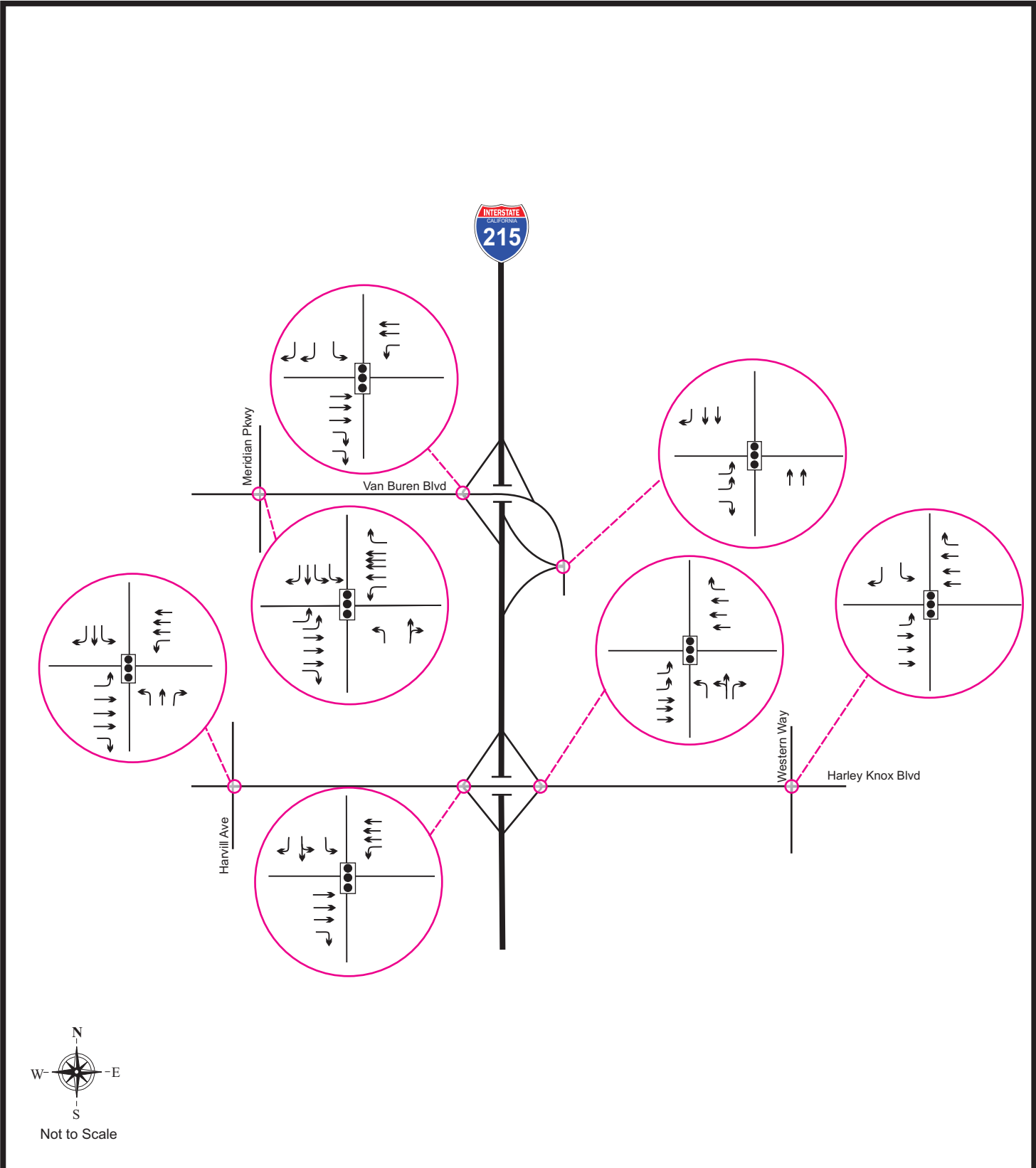

**Horizon Year (2040) Intersection
Lane Geometry - No Build/Existing Conditions**

Figure 7-8g

Legend:

-  Signal
-  Traffic Lane



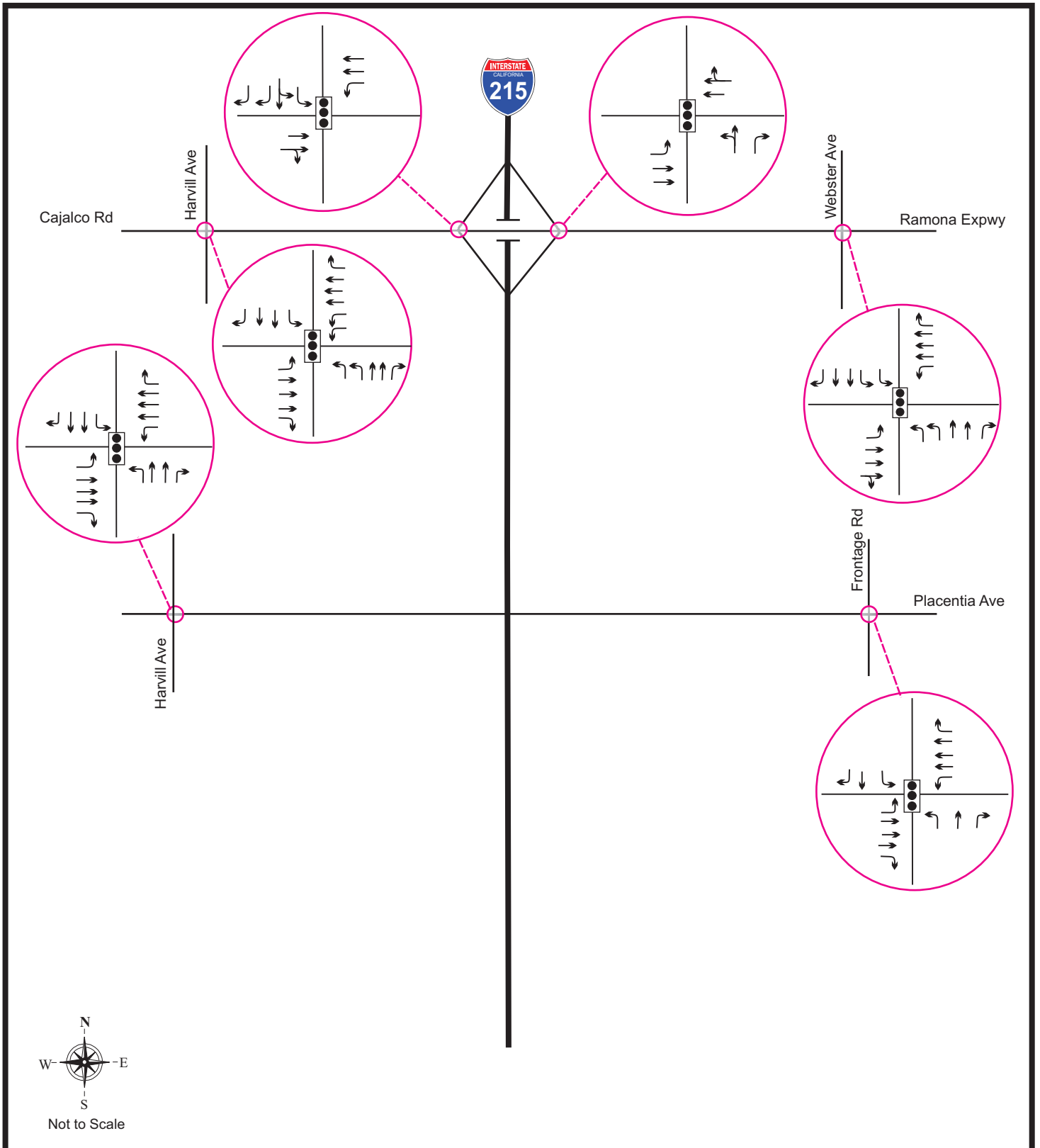

Horizon Year (2040) Intersection Lane Geometry - No Build/Existing Conditions

Figure 7-8h

Legend:



Signal



Traffic Lane



VRPA TECHNOLOGIES, INC.

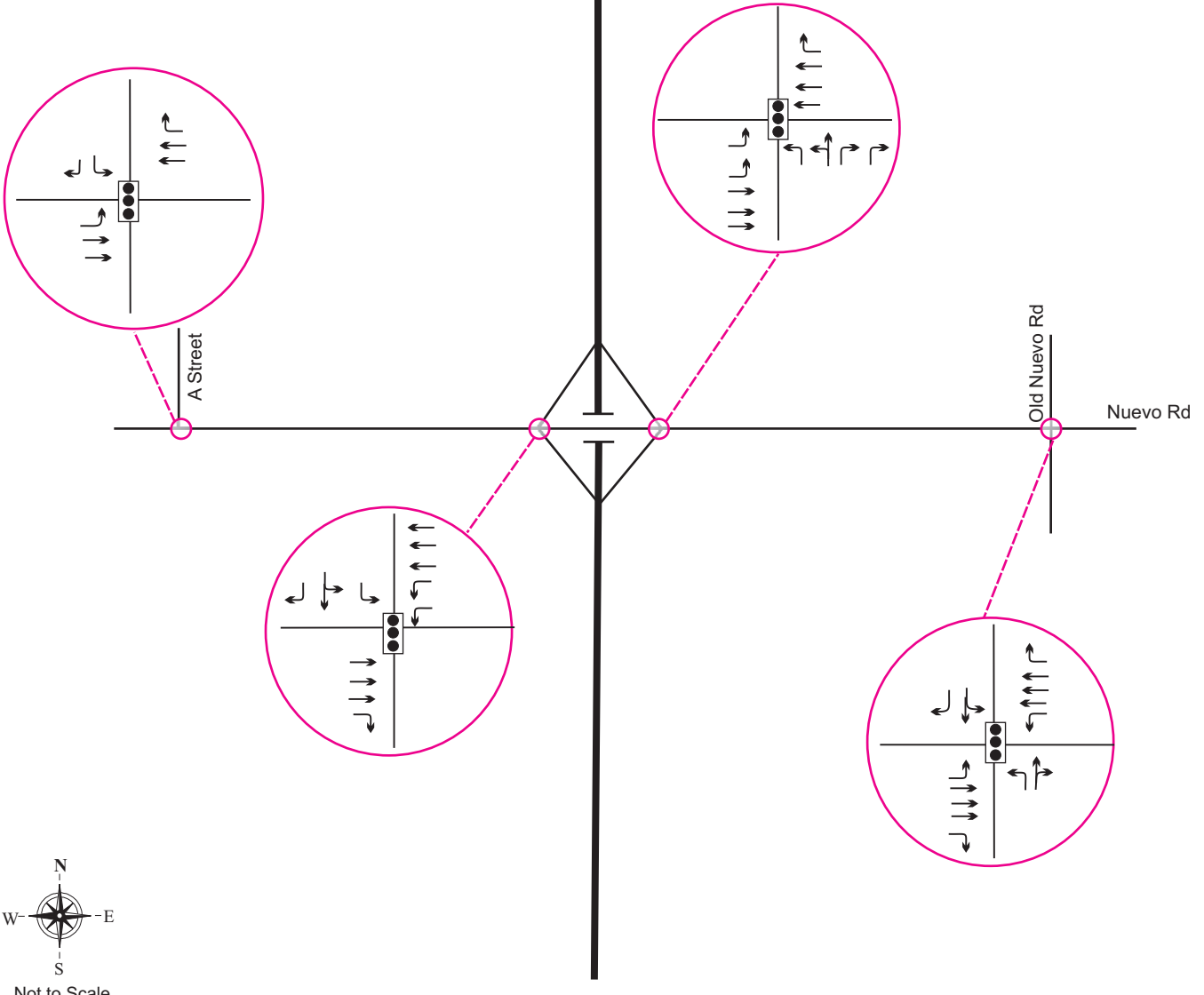

Horizon Year (2040) Intersection Lane Geometry - No Build/Existing Conditions

Figure 7-8i

Legend:



Signal



Traffic Lane



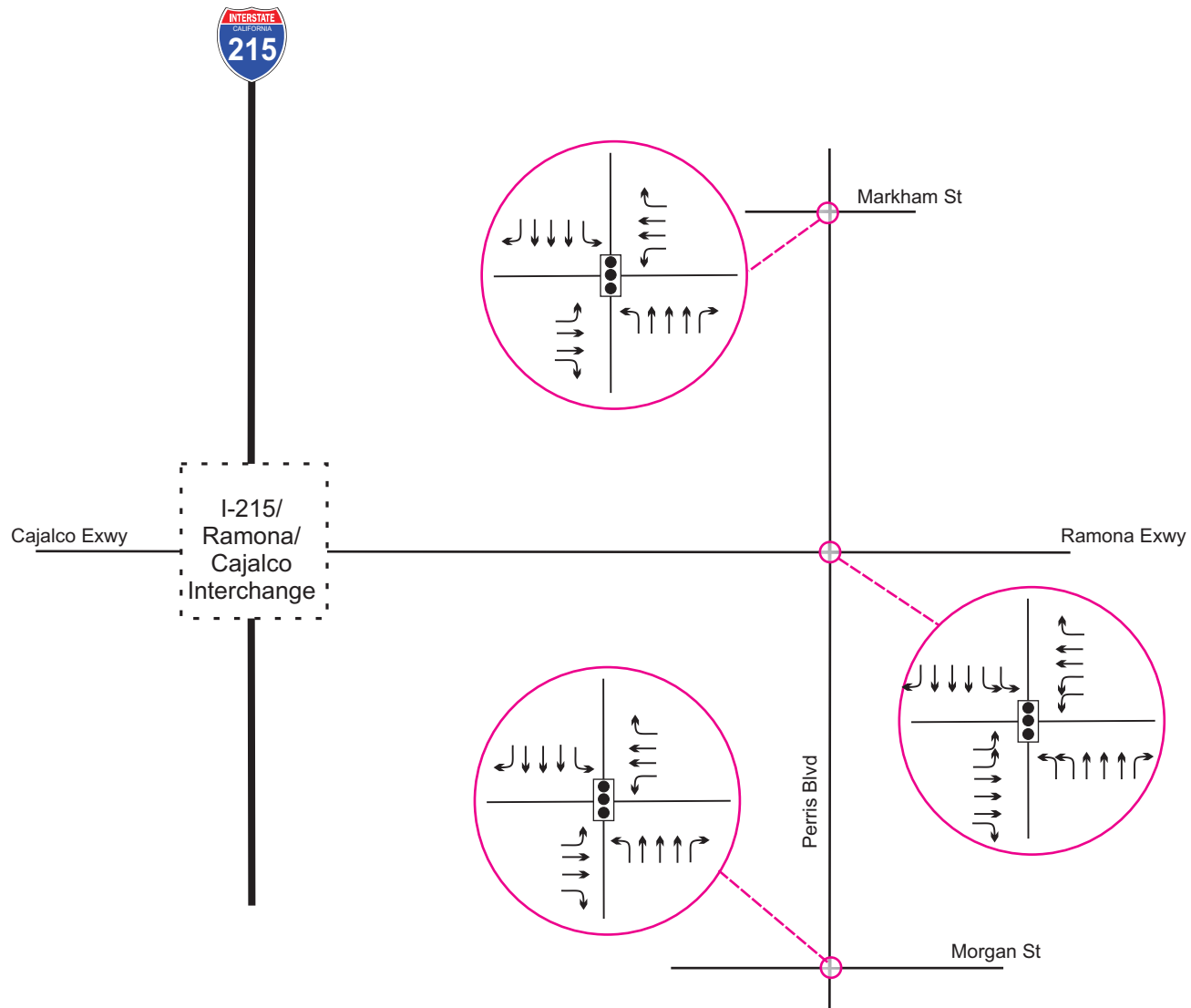

**Horizon Year (2040) Intersection
Lane Geometry - No Build/Existing Conditions**

Figure 7-8j

Legend:

-  Signal
-  Traffic Lane



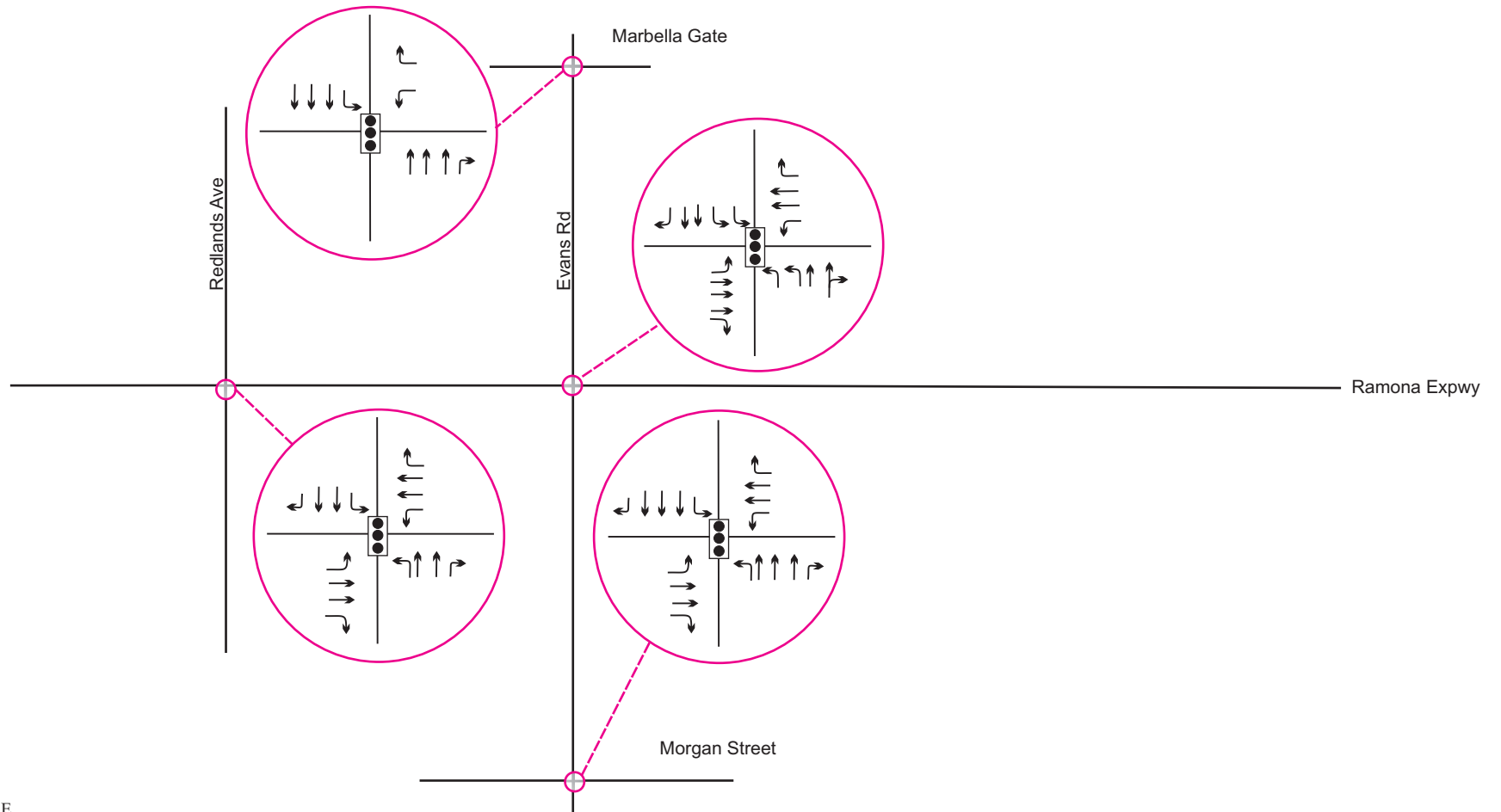

**Horizon Year (2040) Intersection
Lane Geometry - No Build/Existing Conditions**

Figure 7-8k

Legend:



Signal



Traffic Lane



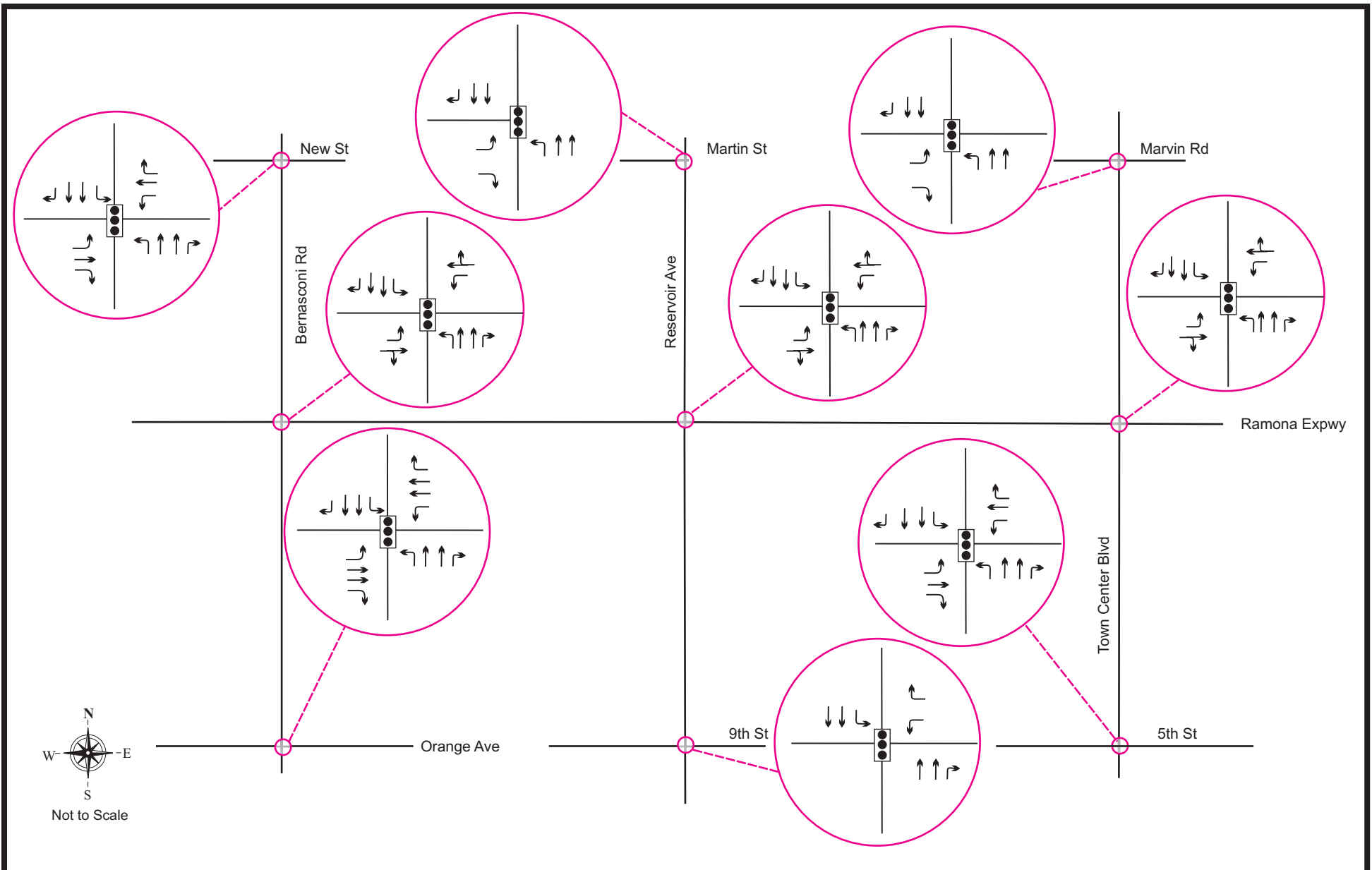

**Horizon Year (2040) Intersection
Lane Geometry - No Build/Existing Conditions**

Figure 7-8I

Legend:



Signal



Traffic Lane



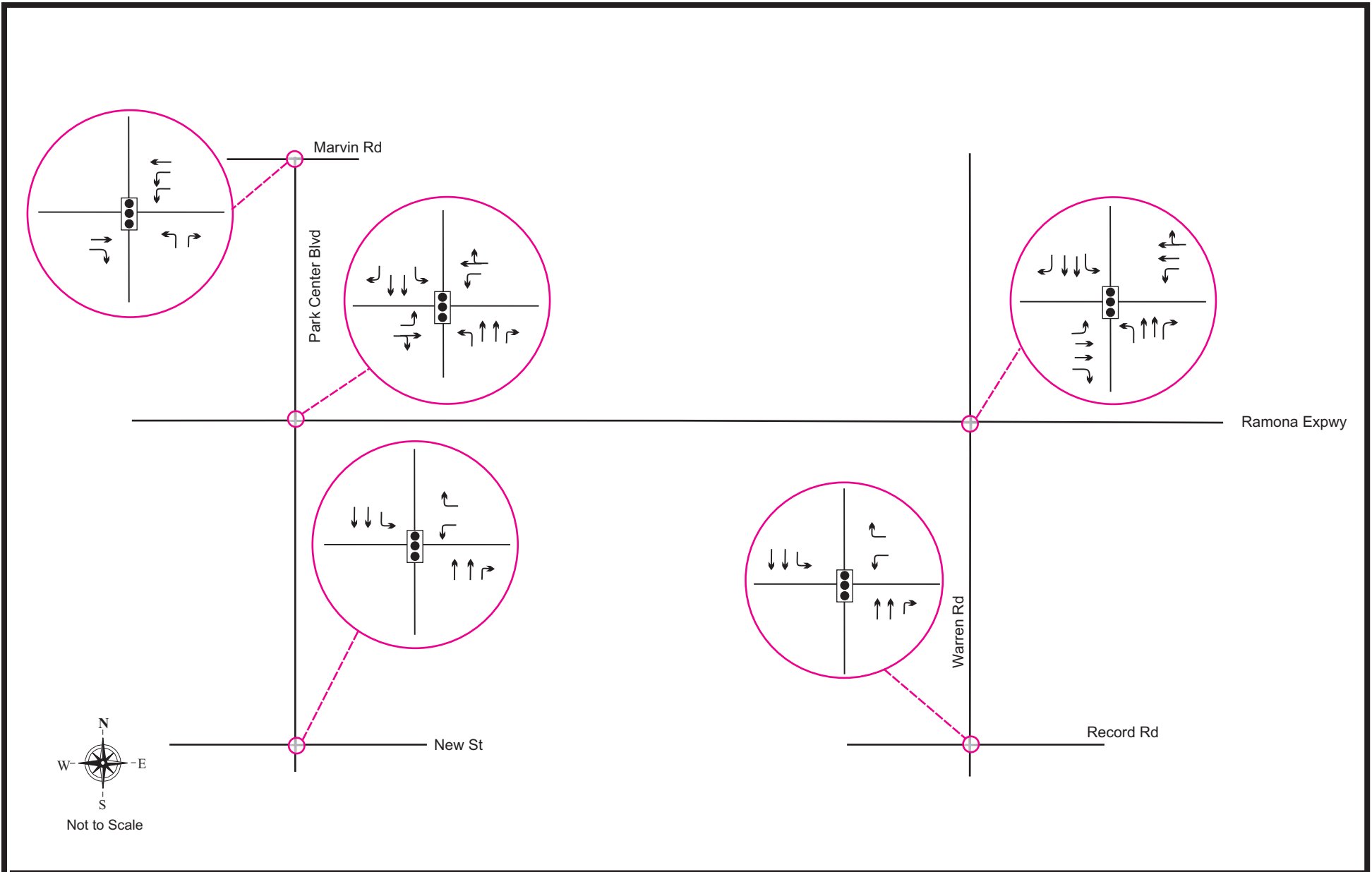

**Horizon Year (2040) Intersection
Lane Geometry - No Build/Existing Conditions**

Figure 7-8m

Legend:

-  Signal
-  Traffic Lane



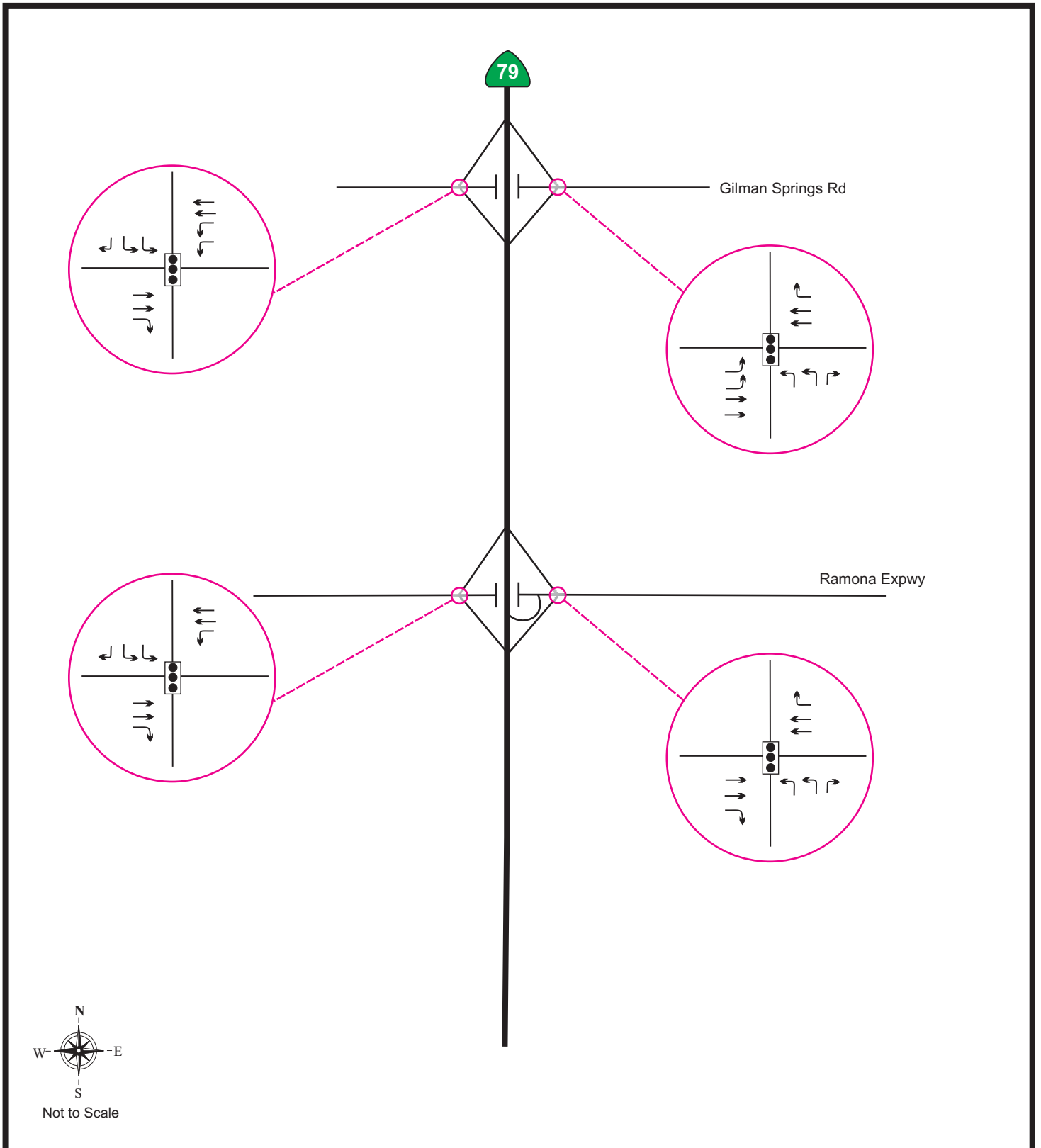

**Horizon Year (2040) Intersection
Lane Geometry - No Build/Existing Conditions**

Figure 7-8n

Legend:



Signal



Traffic Lane



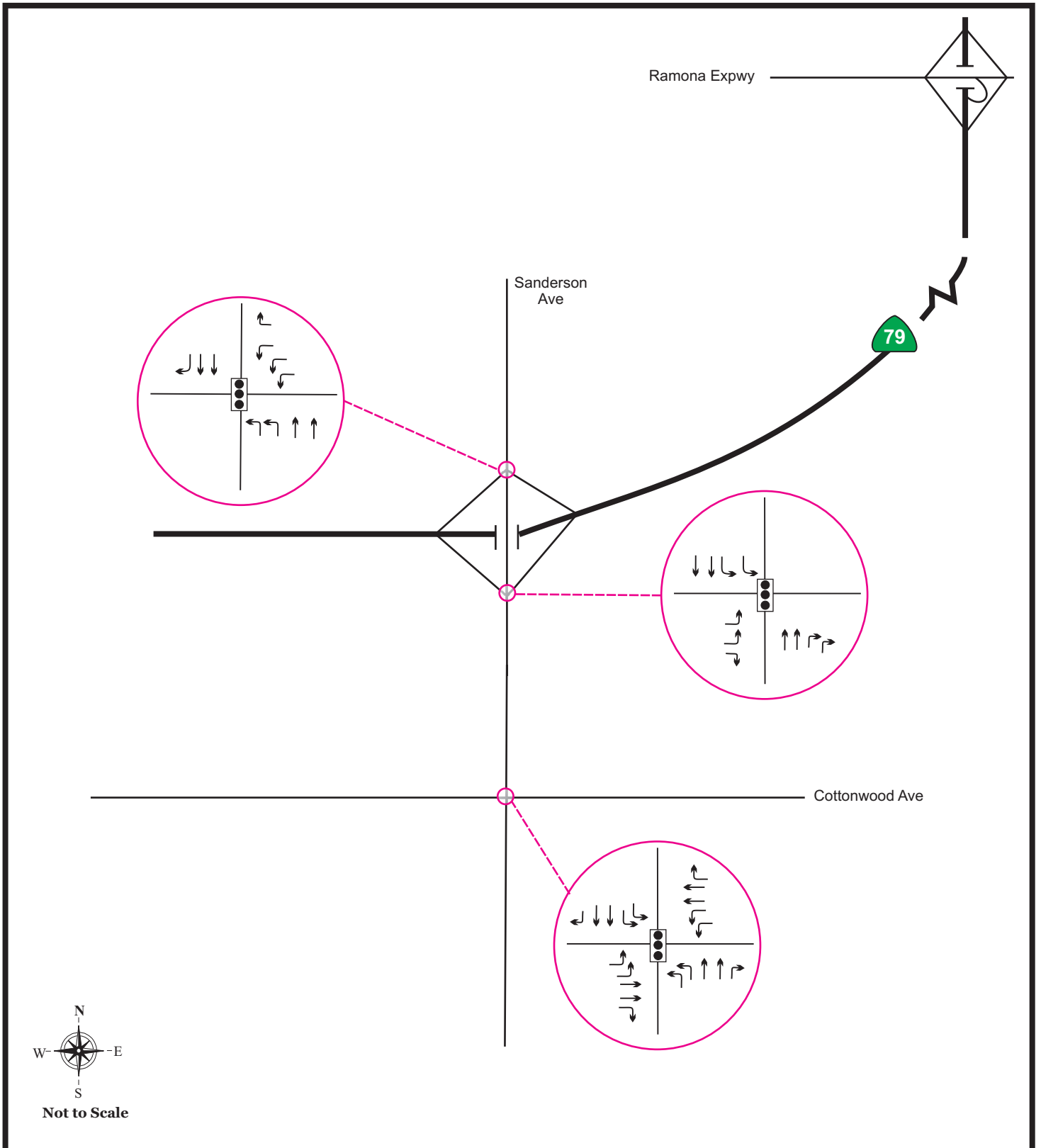

**Horizon Year (2040) Intersection
Lane Geometry - No Build/Existing Conditions**

Figure 7-8o

Legend:



Signal



Traffic Lane



VRPA TECHNOLOGIES, INC.

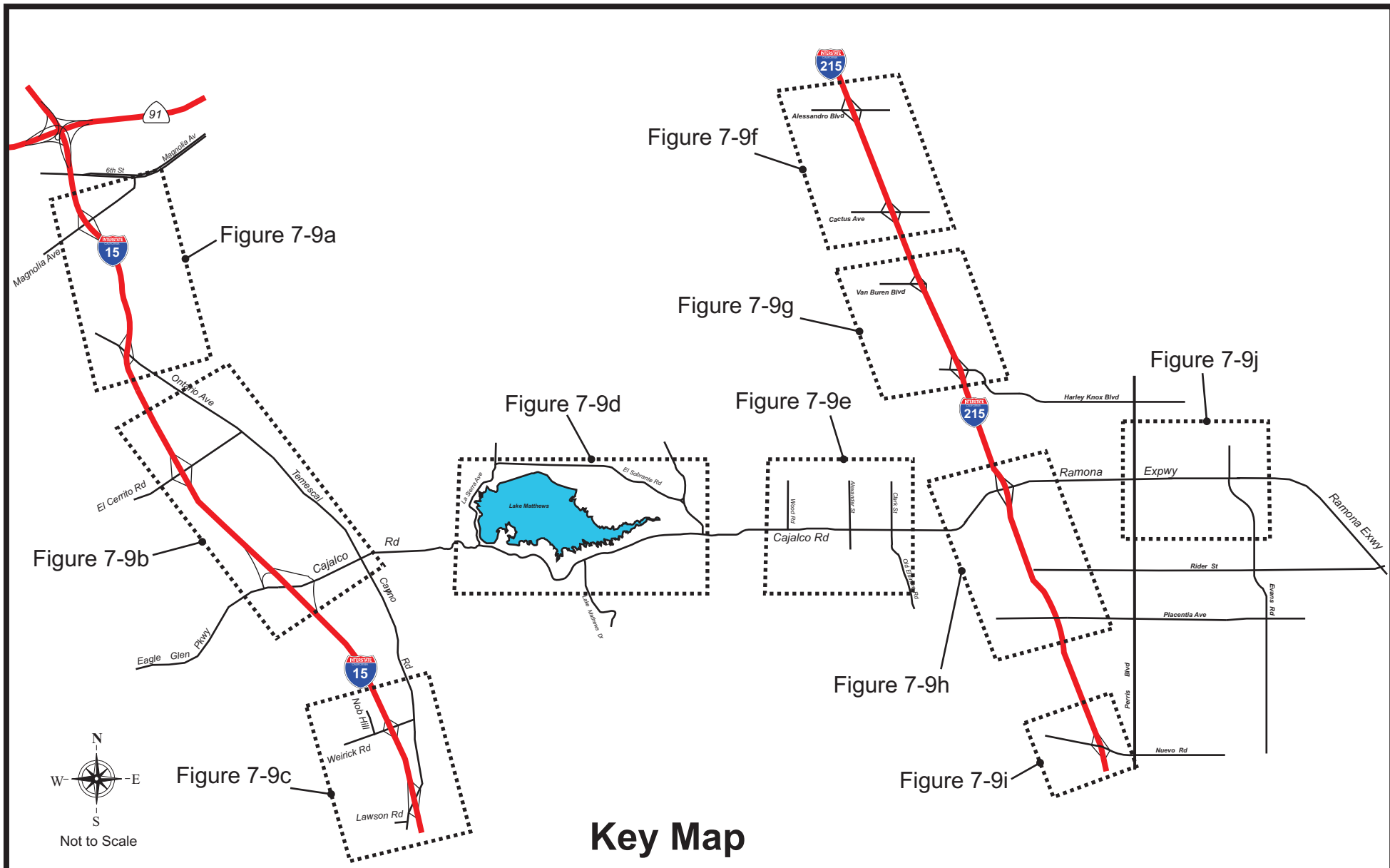

**Horizon Year (2040) Intersection Lane Geometry
No Build/County General Plan**

Figure 7-9

Legend:

 **Figure Areas**



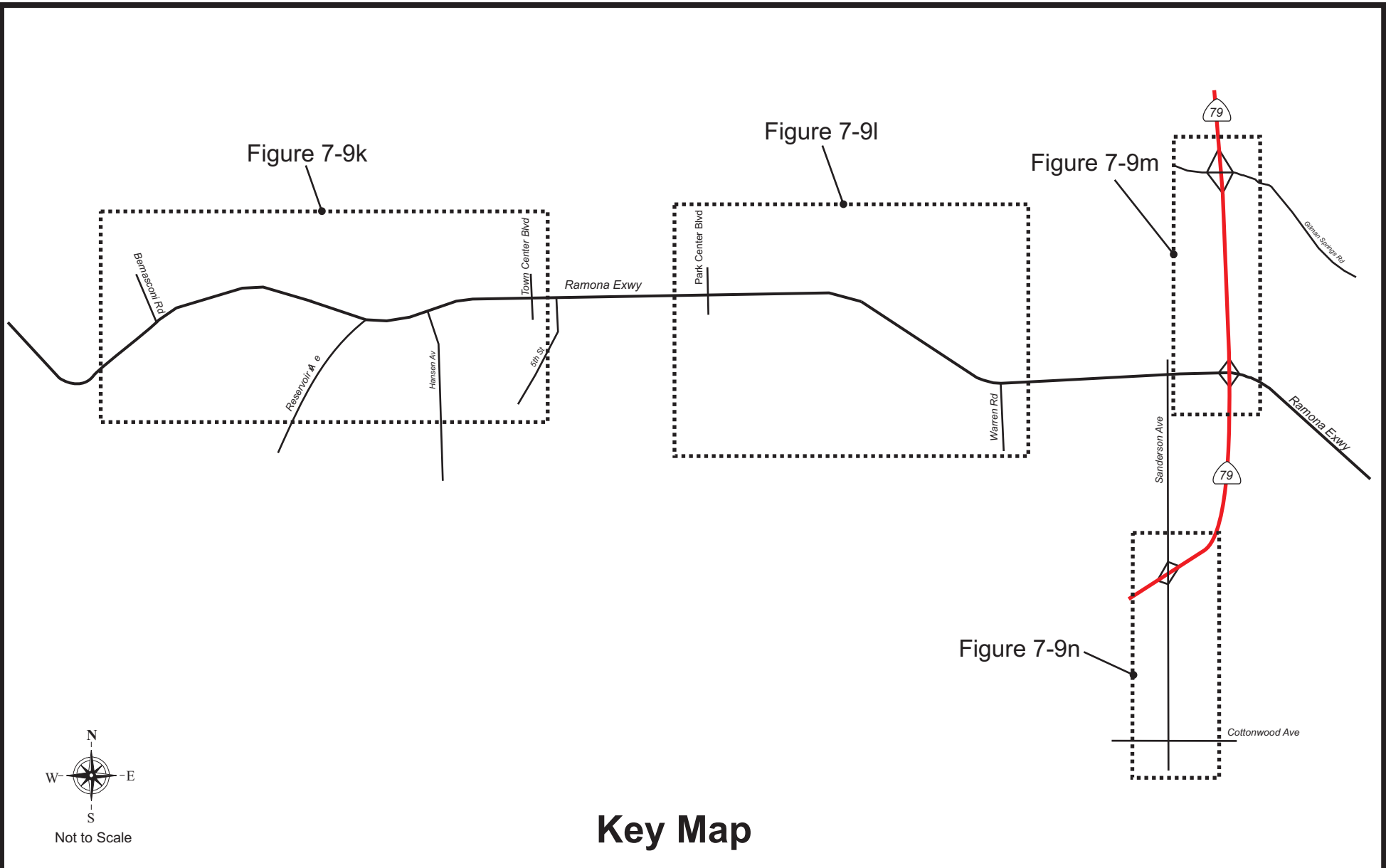

Key Map

**Horizon Year (2040) Intersection Lane Geometry
No Build/County General Plan**

Figure 7-9 (cont.)

Legend:

 Figure Areas



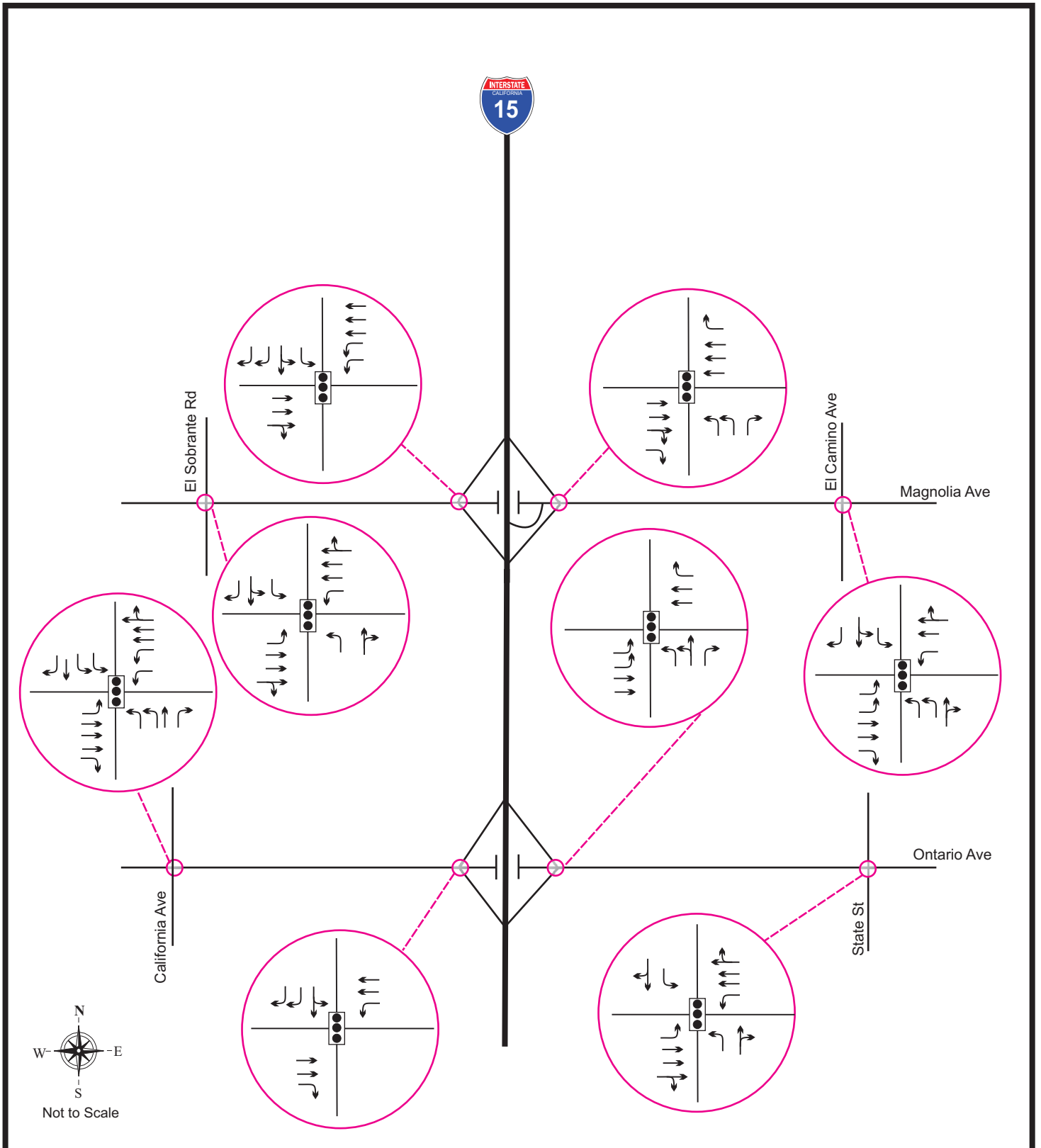

**Horizon Year (2040) Intersection
Lane Geometry - No Build/County General Plan**

Figure 7-9a

Legend:



Signal



Traffic Lane



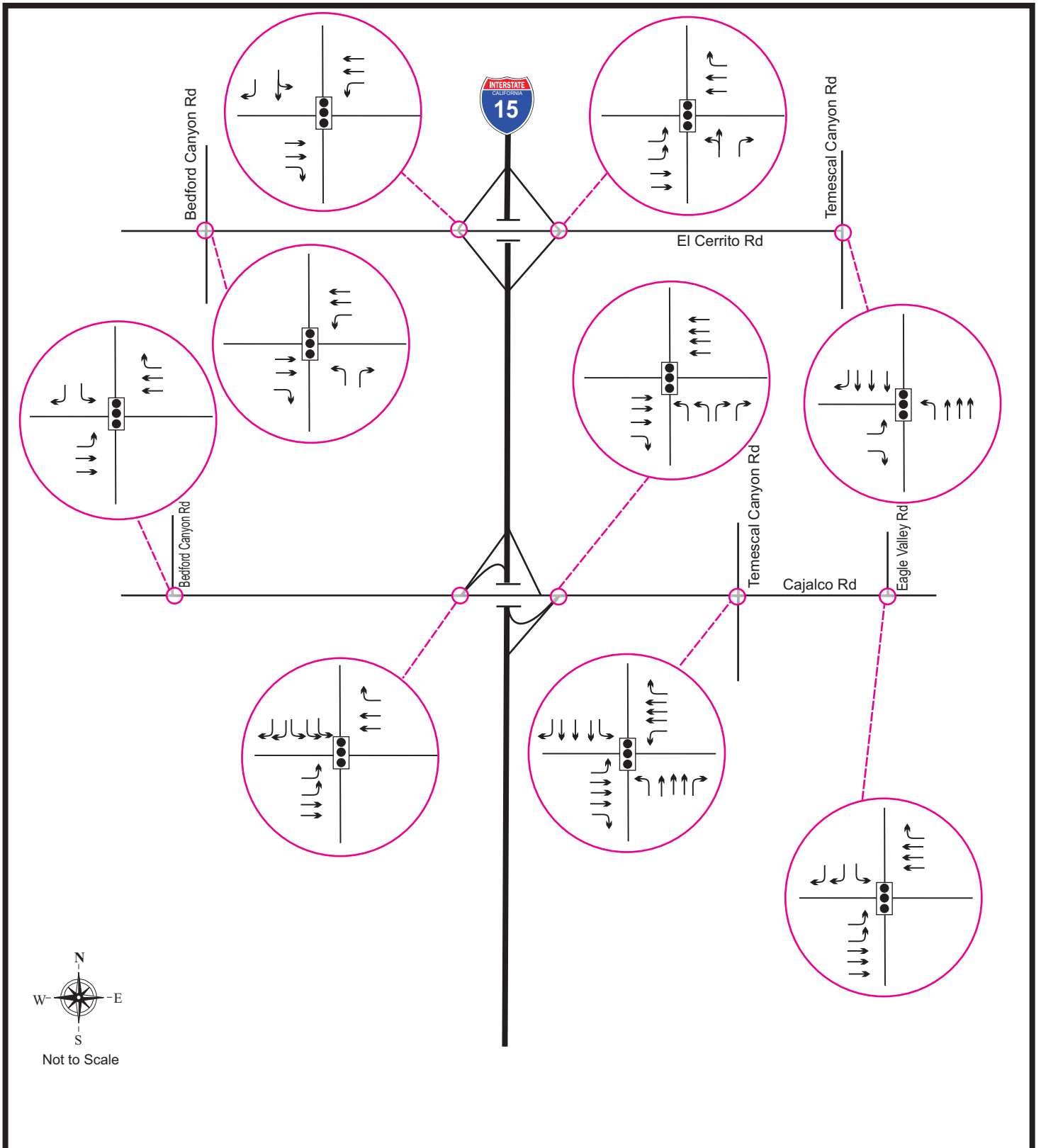

**Horizon Year (2040) Intersection
Lane Geometry - No Build/County General Plan**

Figure 7-9b

Legend:



Signal



Traffic Lane



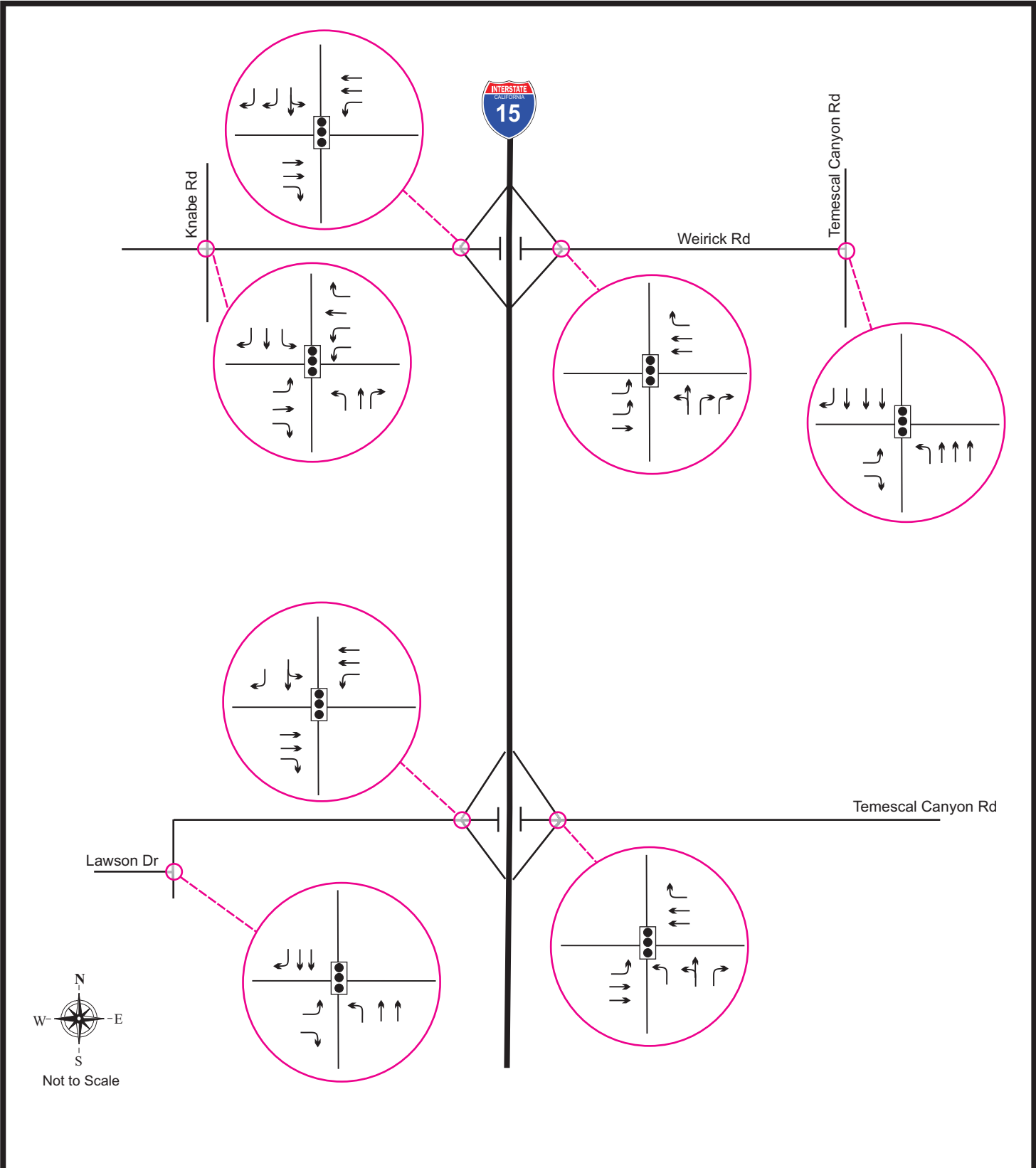

**Horizon Year (2040) Intersection
Lane Geometry - No Build/County General Plan**

Figure 7-9c

Legend:

-  Signal
-  Traffic Lane



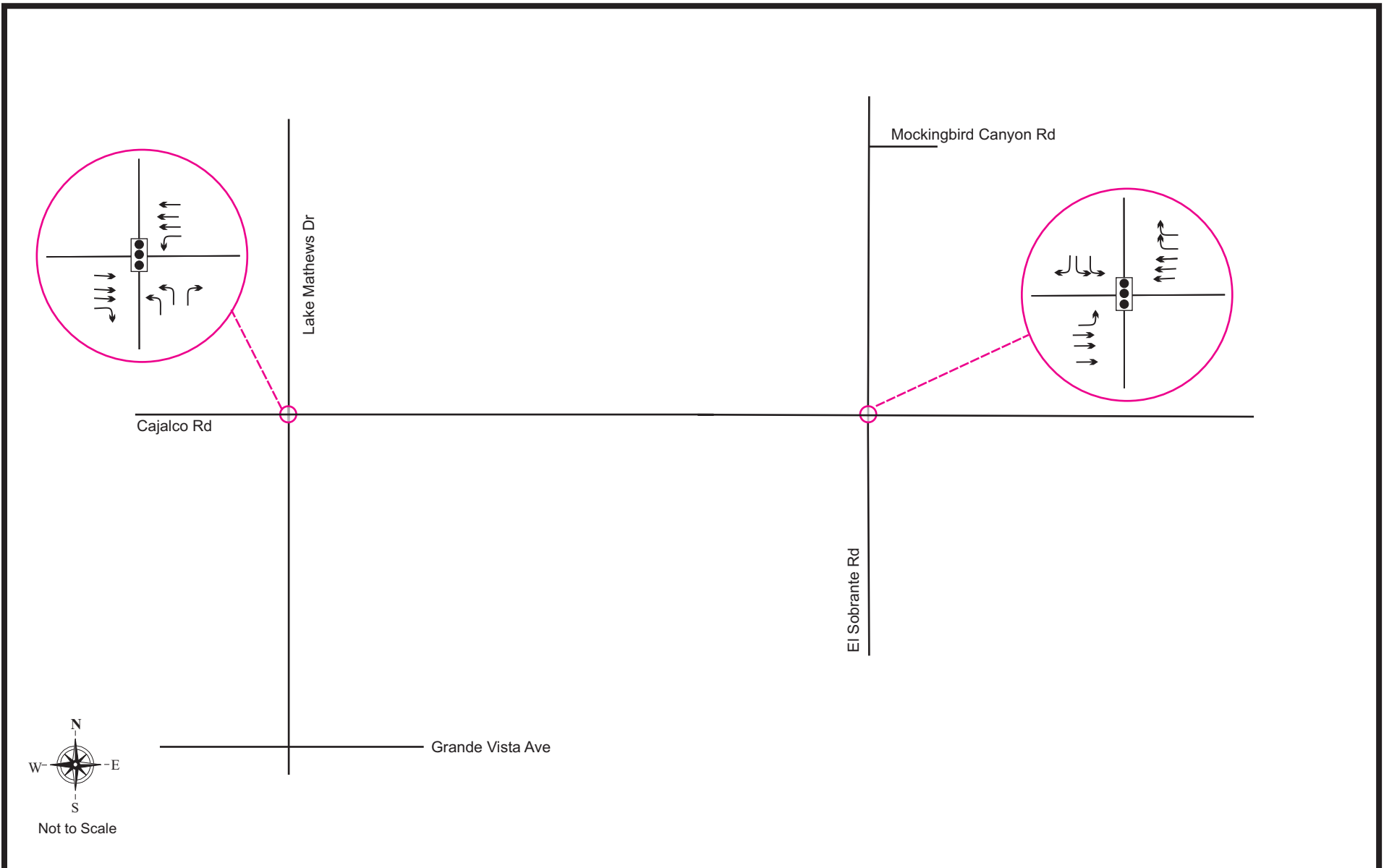

**Horizon Year (2040) Intersection
Lane Geometry - No Build/County General Plan**

Figure 7-9d

Legend:

-  Signal
-  Traffic Lane



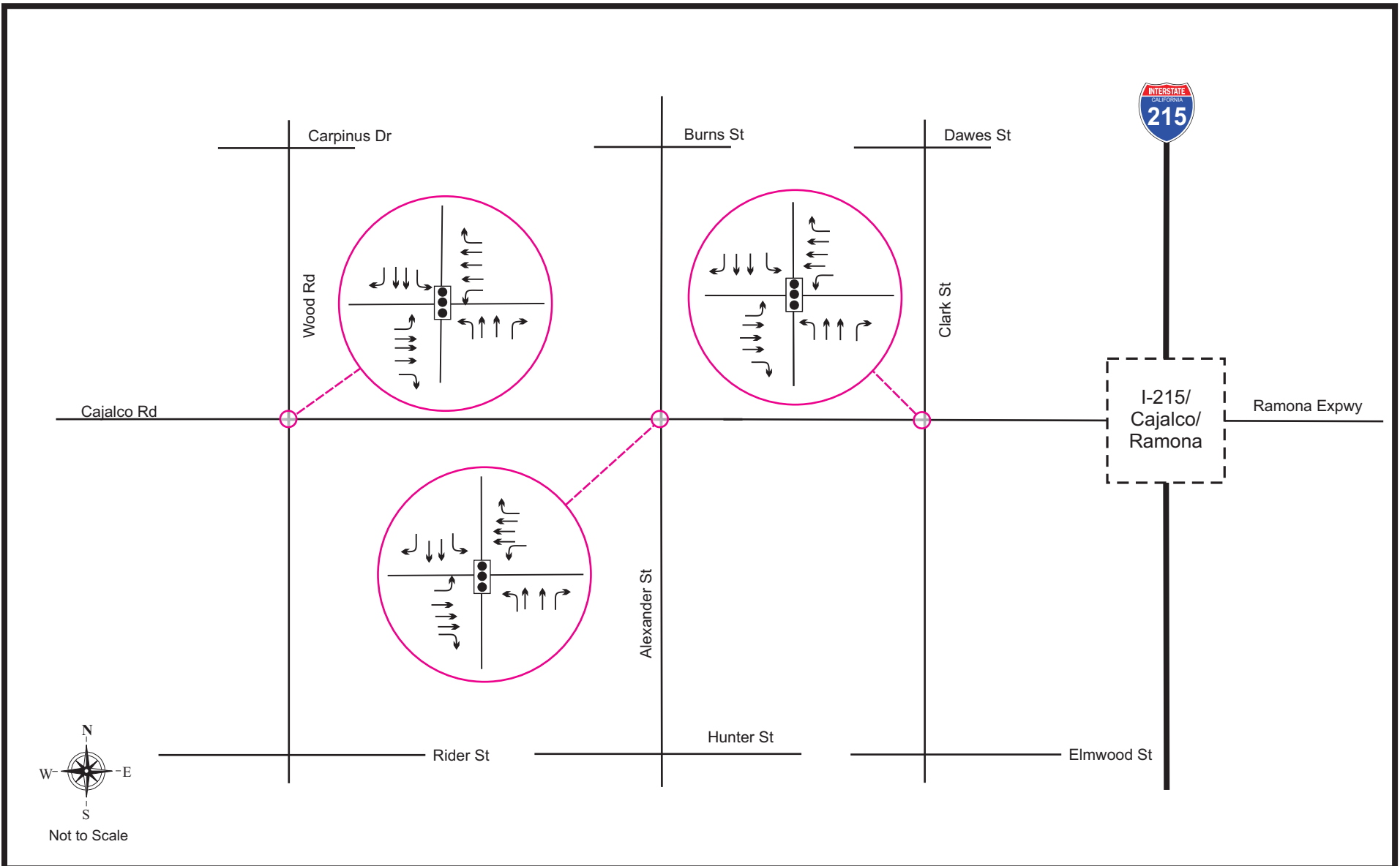

**Horizon Year (2040) Intersection
Lane Geometry - No Build/County General Plan**

Figure 7-9e

Legend:

-  Signal
-  Traffic Lane



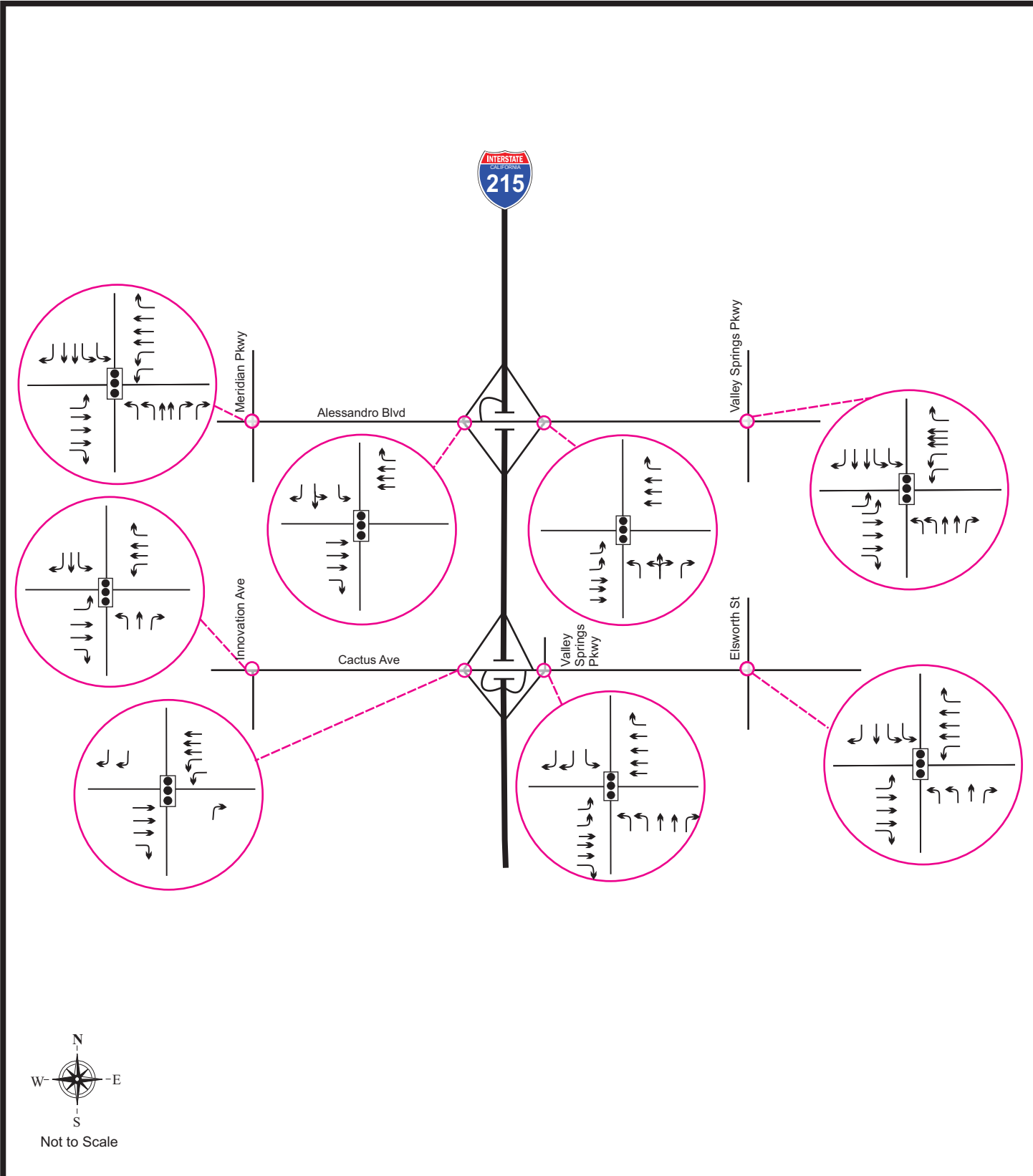

**Horizon Year (2040) Intersection
Lane Geometry - No Build/County General Plan**

Figure 7-9f

Legend:

-  Signal
-  Traffic Lane



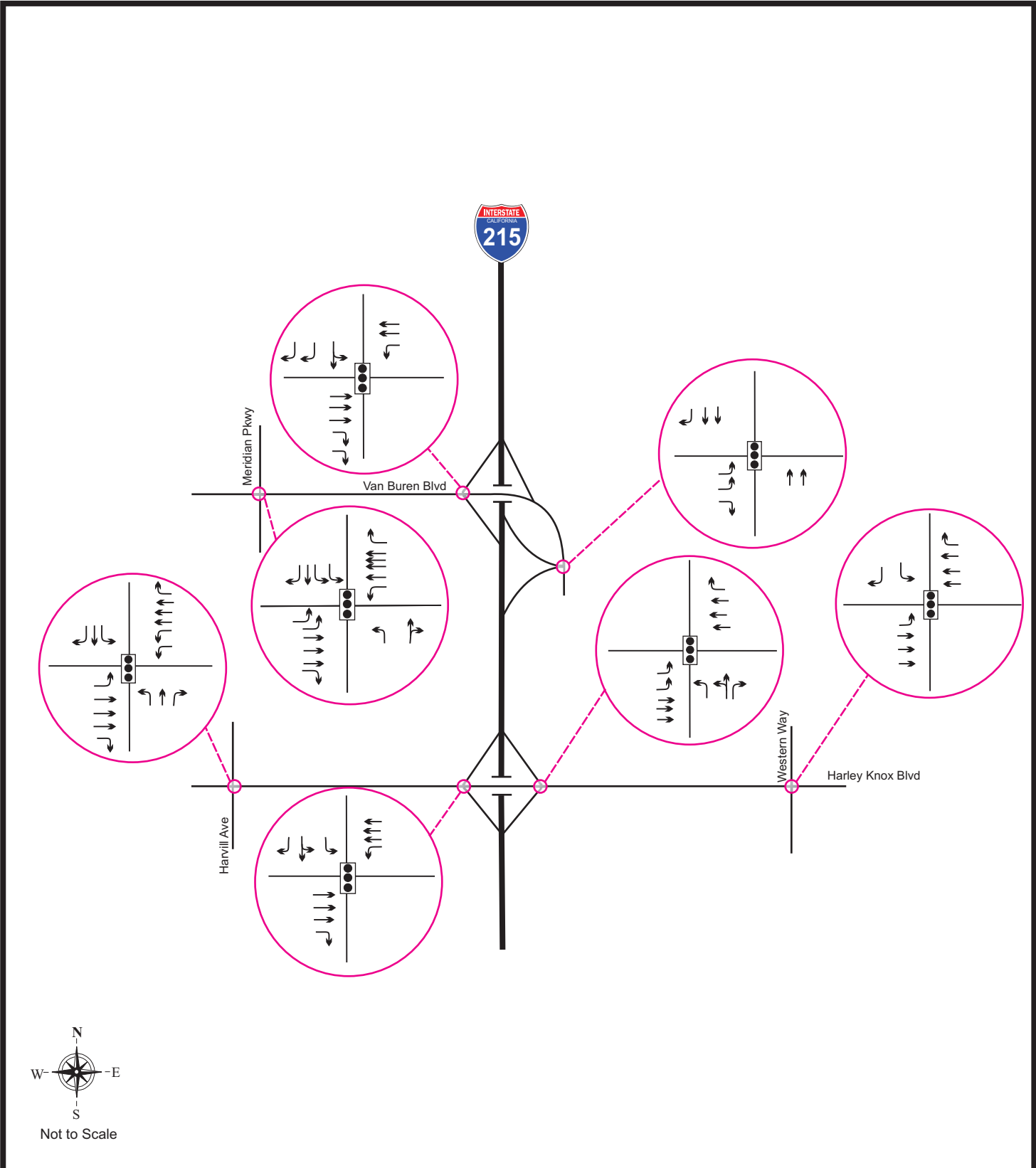

**Horizon Year (2040) Intersection
Lane Geometry - No Build/County General Plan**

Figure 7-9g

Legend:

-  Signal
-  Traffic Lane



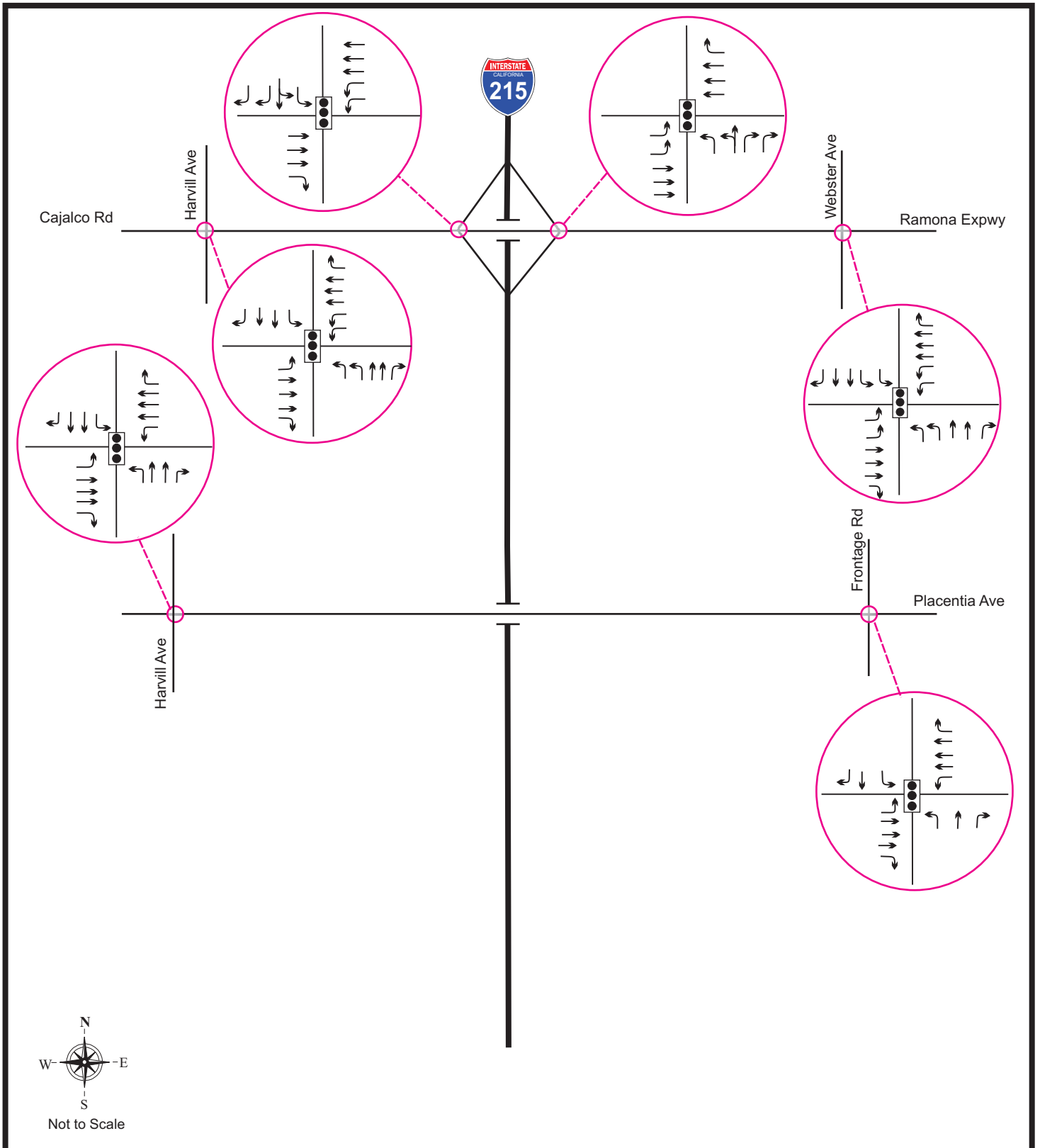

**Horizon Year (2040) Intersection
Lane Geometry - No Build/County General Plan**

Figure 7-9h

Legend:



Signal



Traffic Lane



VRPA TECHNOLOGIES, INC.

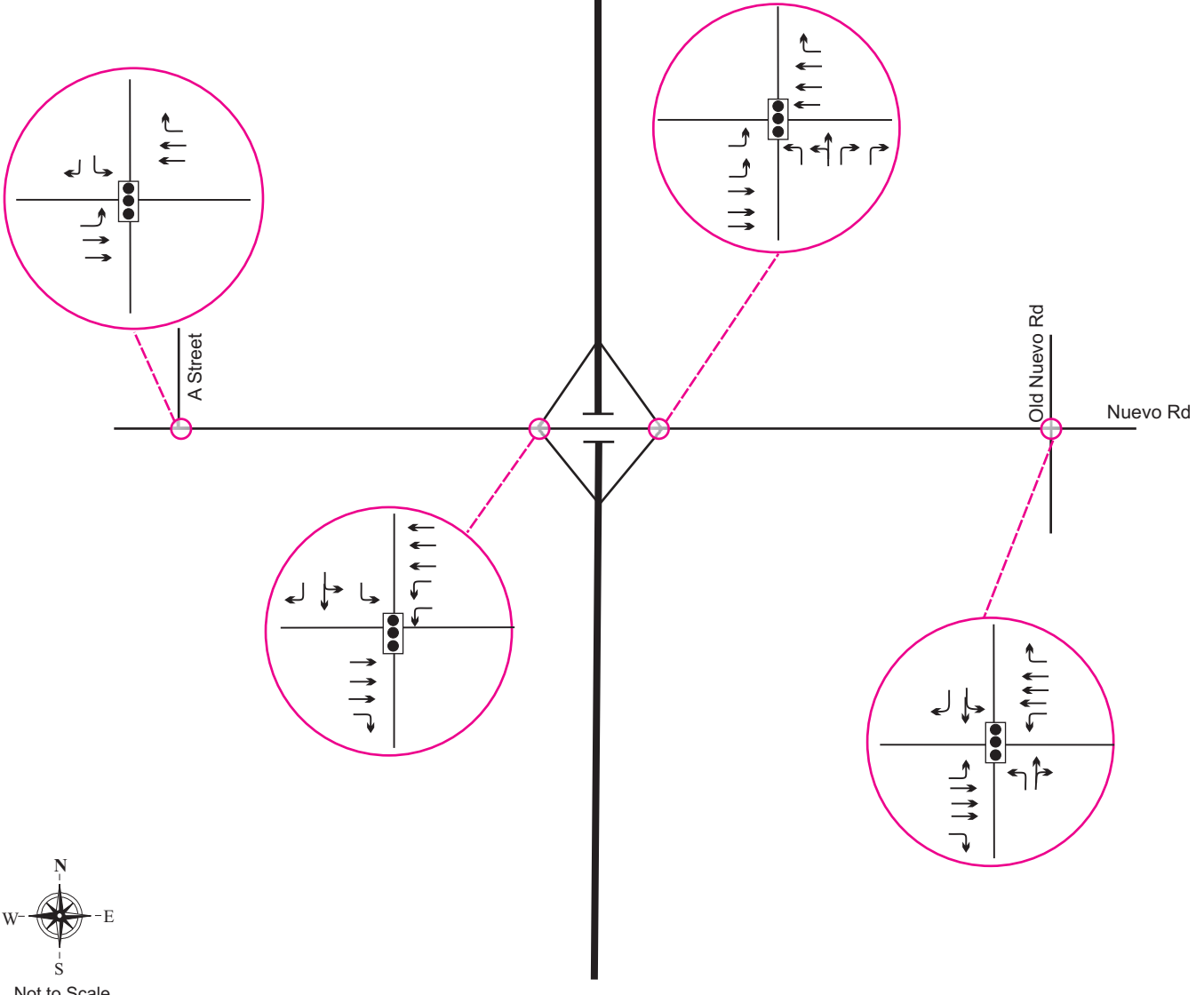

**Horizon Year (2040) Intersection
Lane Geometry - No Build/County General Plan**

Figure 7-9i

Legend:



Signal



Traffic Lane



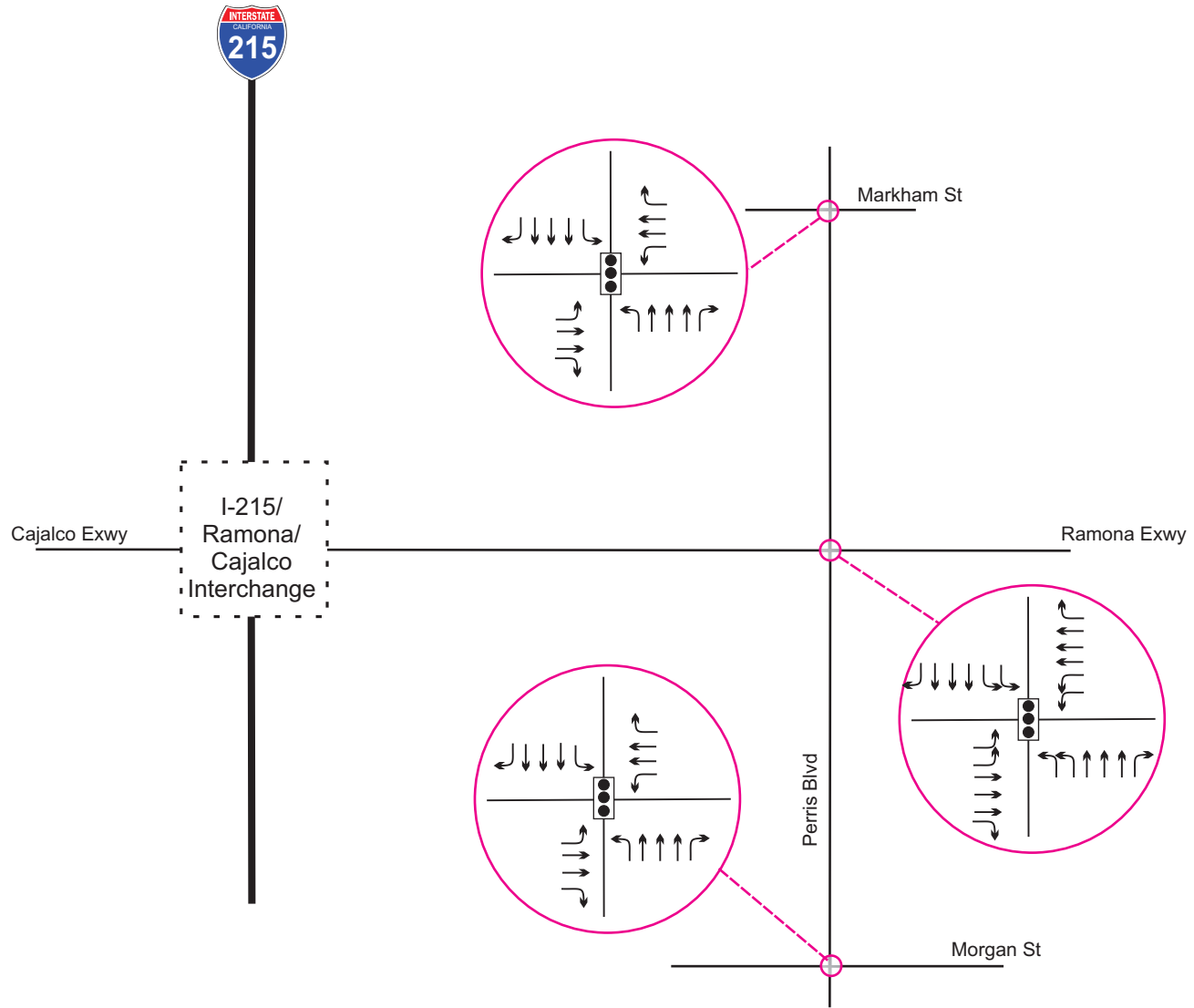

**Horizon Year (2040) Intersection
Lane Geometry - No Build/County General Plan**

Figure 7-9j

Legend:

-  Signal
-  Traffic Lane



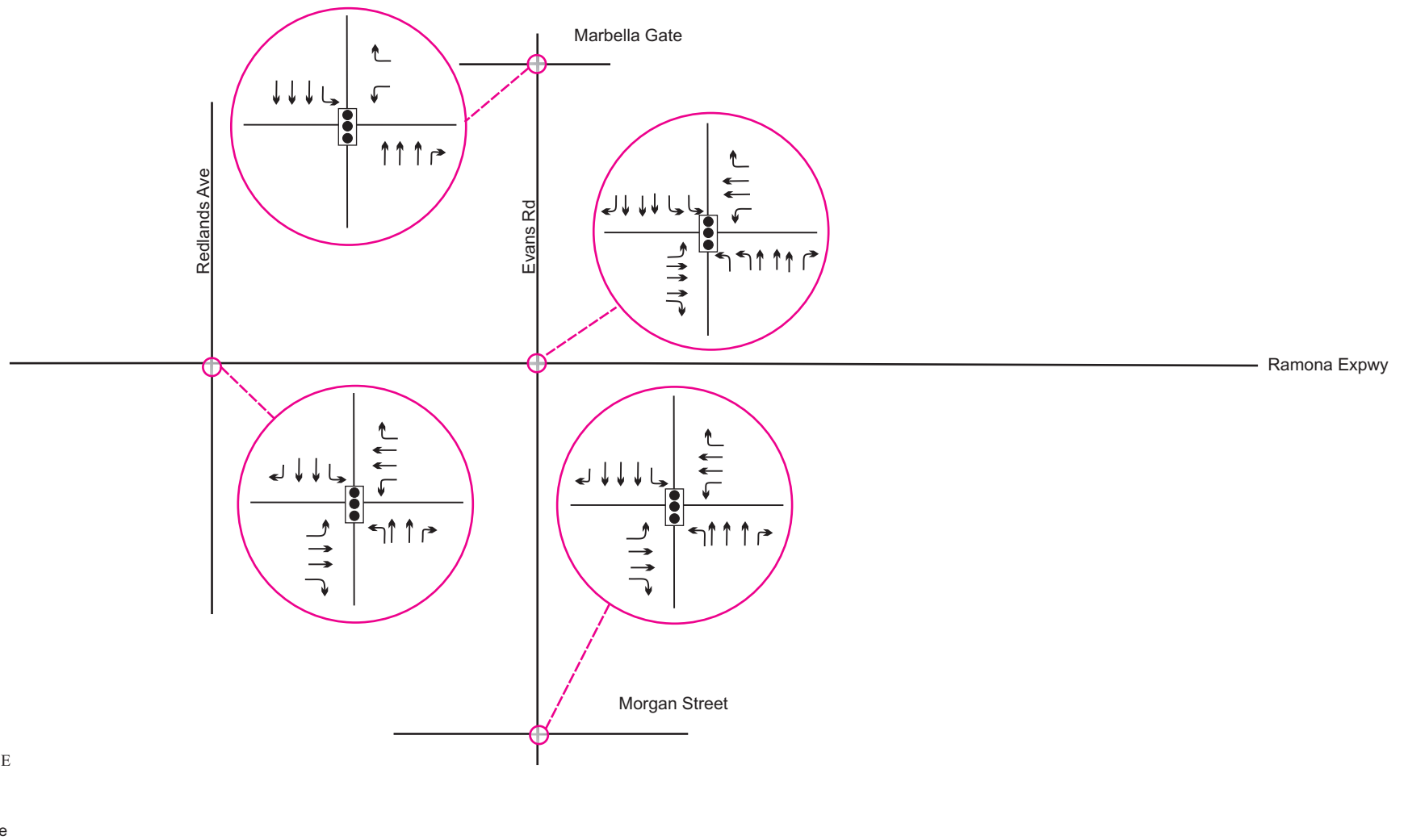

**Horizon Year (2040) Intersection
Lane Geometry - No Build/County General Plan**

Figure 7-9k

Legend:

-  Signal
-  Traffic Lane



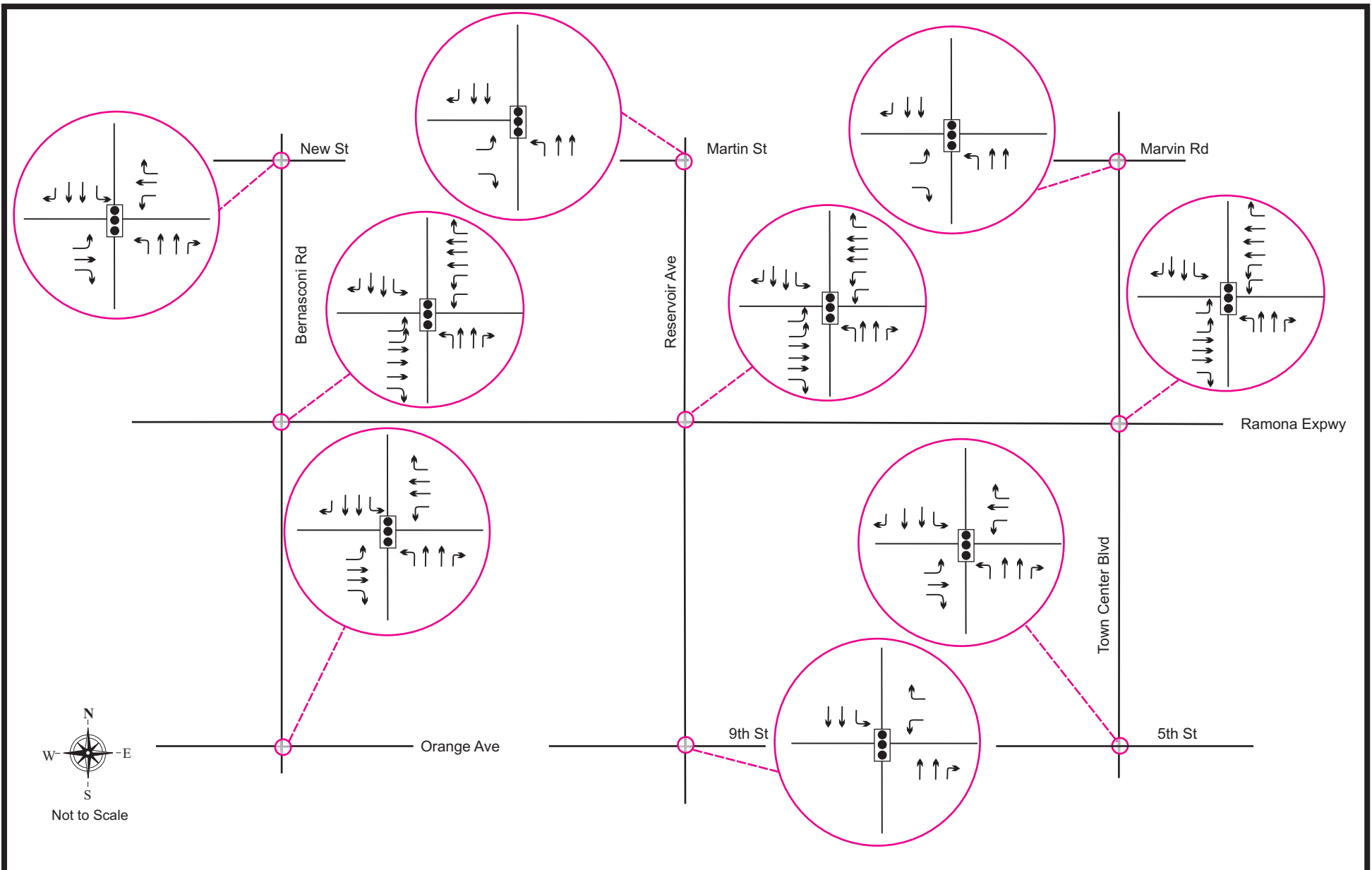

**Horizon Year (2040) Intersection
Lane Geometry - No Build/County General Plan**

Figure 7-9I

Legend:



Signal



Traffic Lane



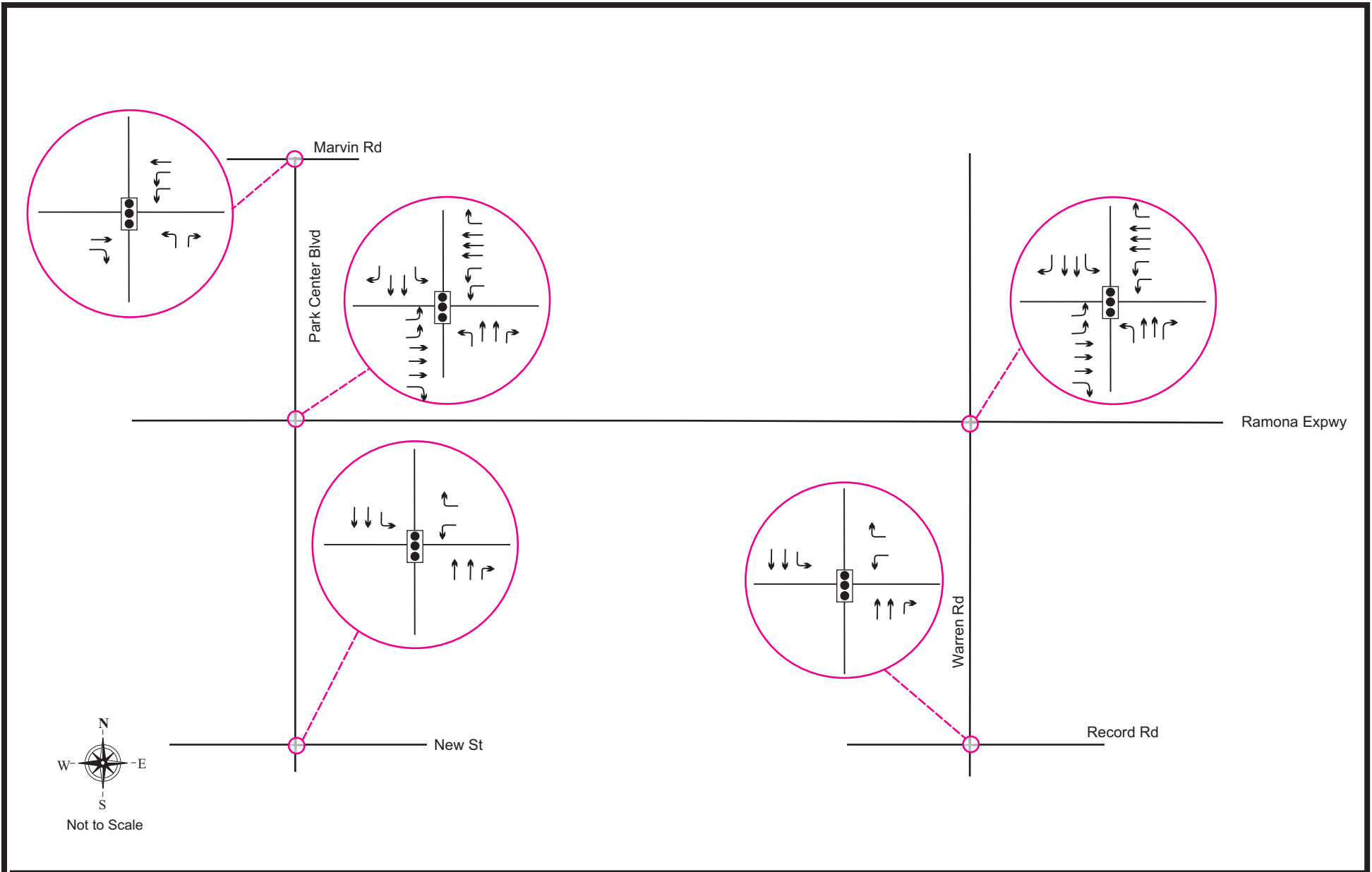

**Horizon Year (2040) Intersection
Lane Geometry - No Build/County General Plan**

Figure 7-9m

Legend:

-  Signal
-  Traffic Lane



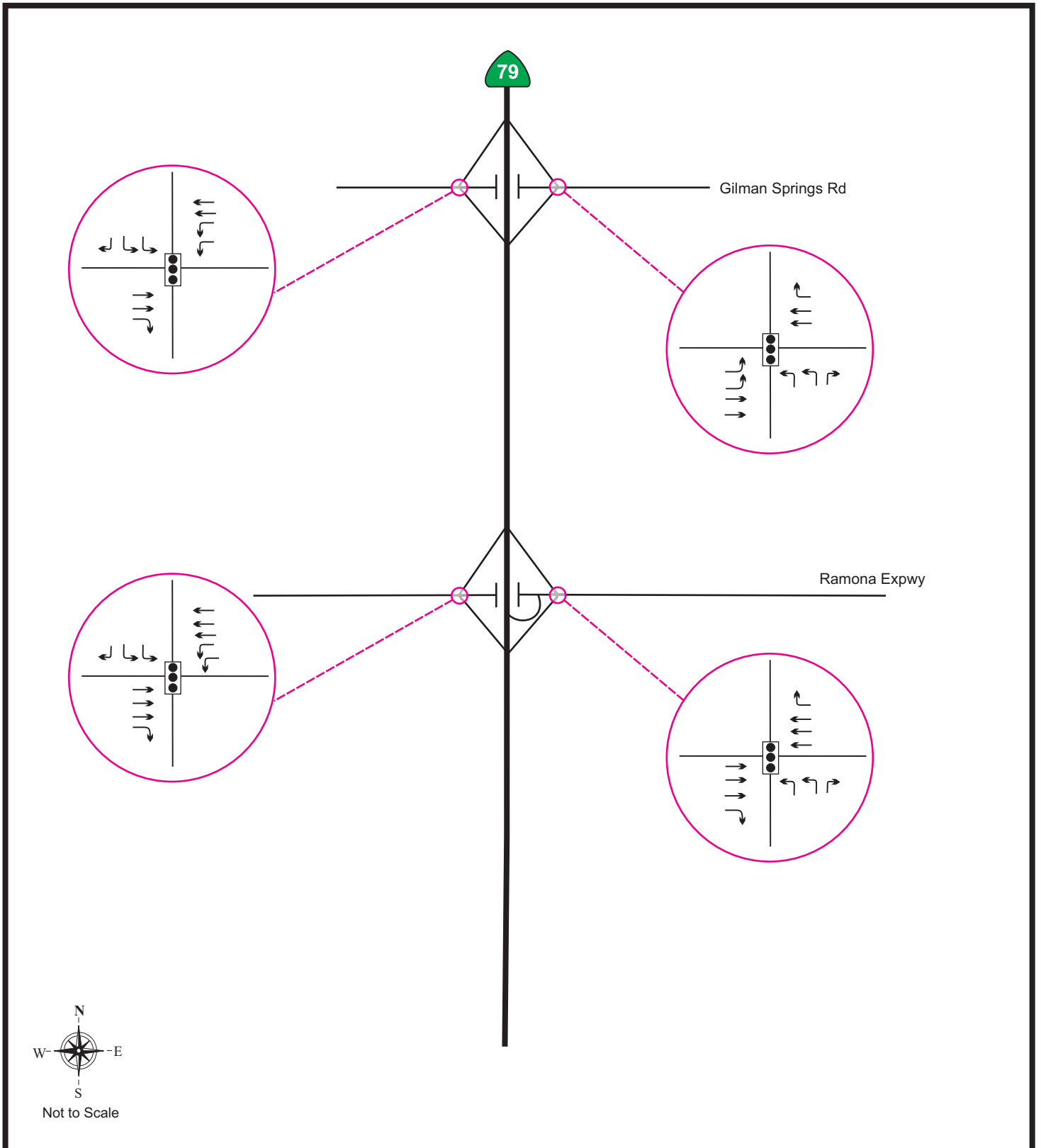

Horizon Year (2040) Intersection Lane Geometry - No Build/County General Plan

Figure 7-9n

Legend:

-  Signal
-  Traffic Lane



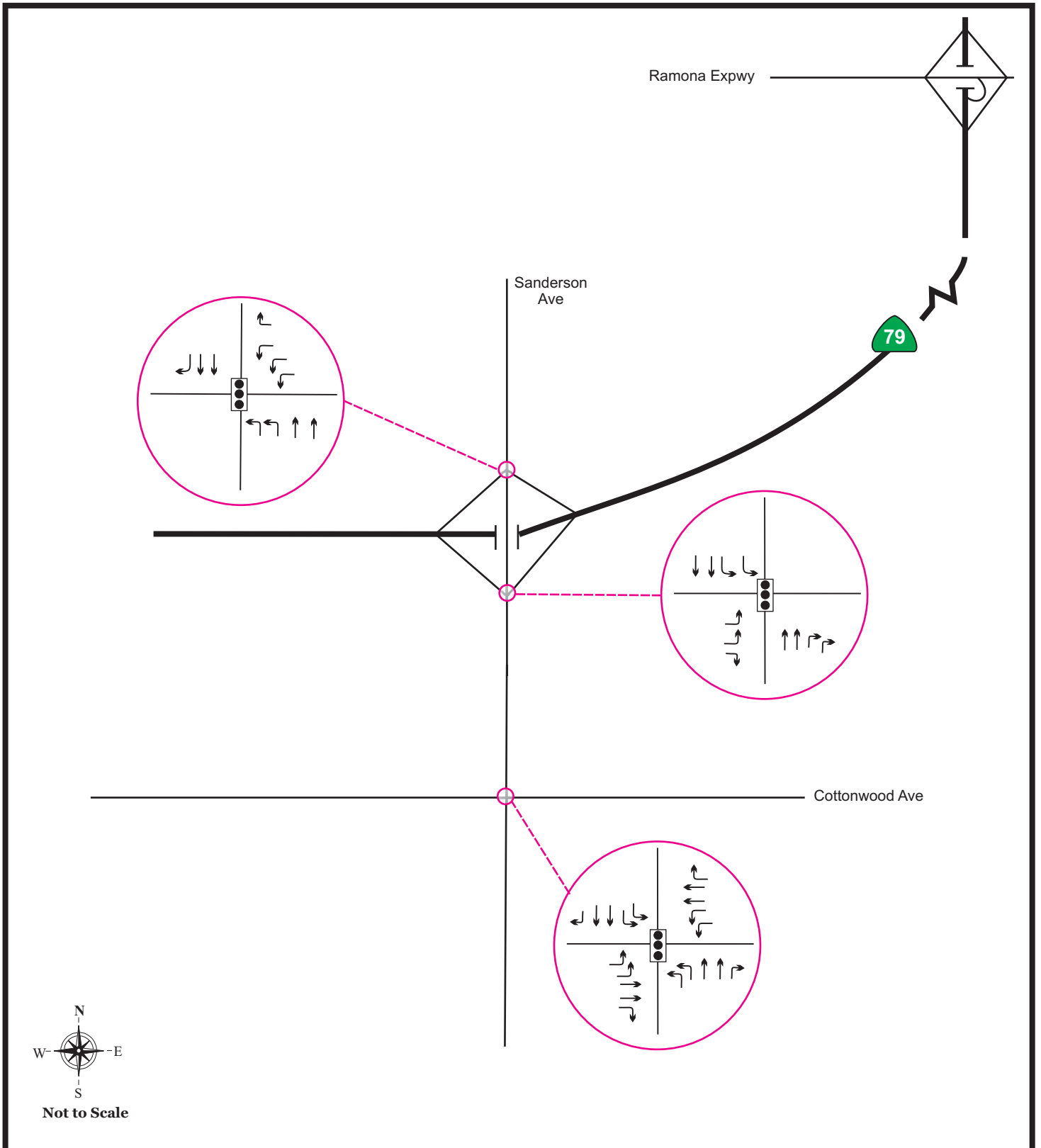

**Horizon Year (2040) Intersection
Lane Geometry - No Build/County General Plan**

Figure 7-9o

Legend:



Signal



Traffic Lane



VRPA TECHNOLOGIES, INC.

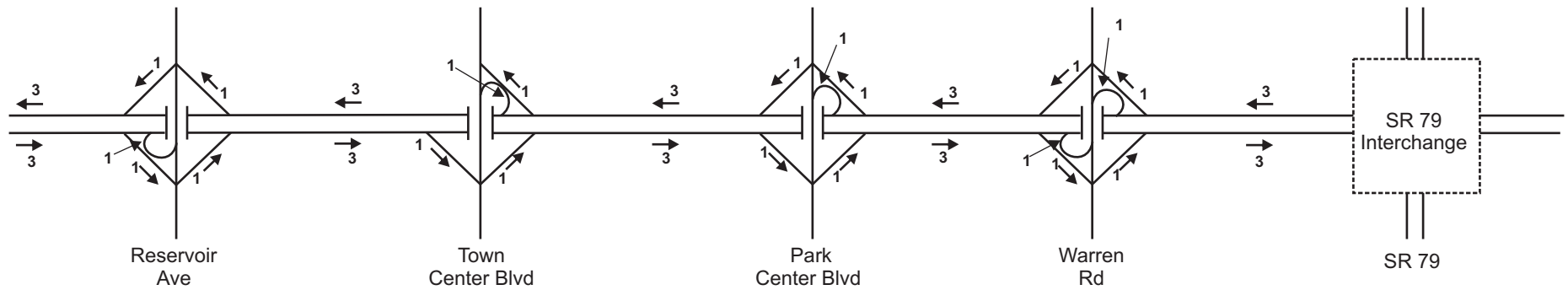
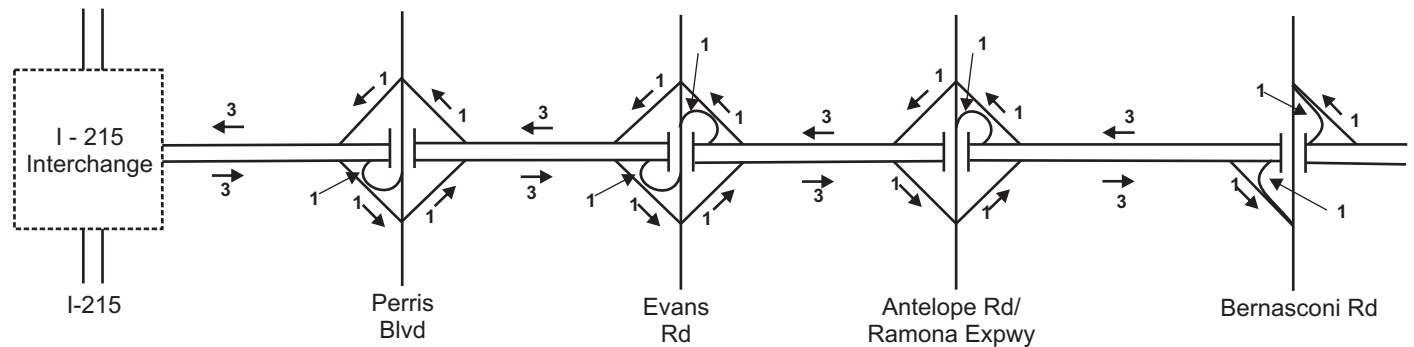

**Horizon Year (2040) Freeway Mainline Lane Geometry
Mid County Parkway - Alternative 4 Modified**

Figure 7-10

Legend

←^x Number of Lanes



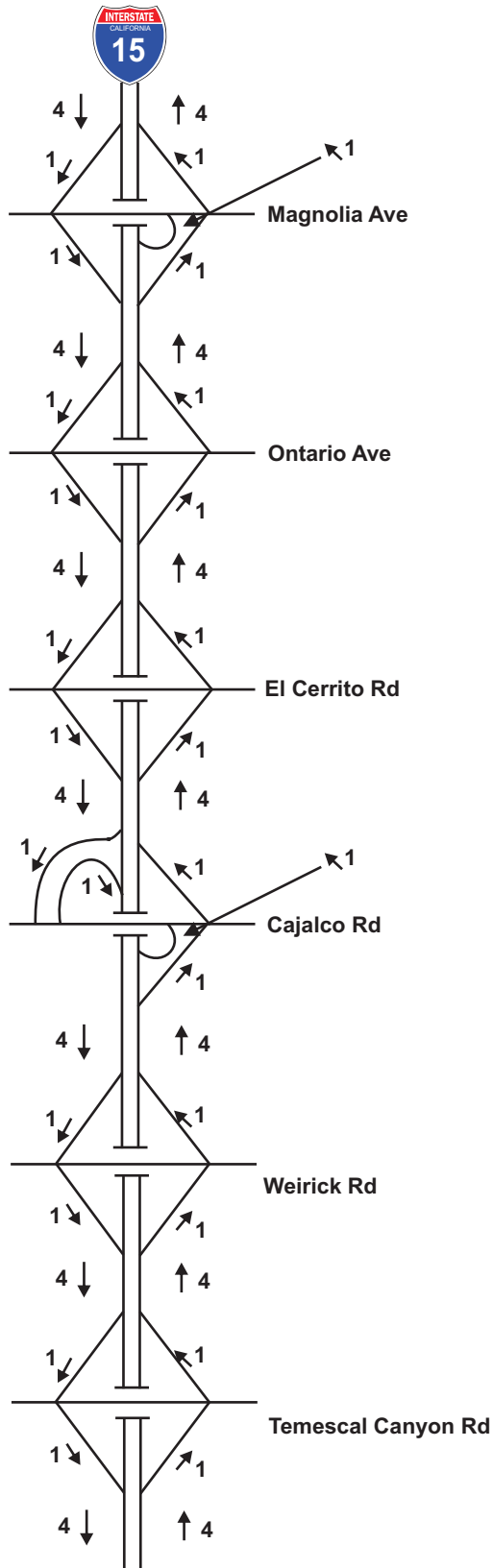

Note:
Two Express Lanes in each direction of travel will be provided in addition to the lanes indicated on I-15.

**Horizon Year (2040) Freeway Mainline Lane Geometry
Interstate 15 - Alternative 4 Modified**

Figure 7-11

Legend

- Direction of Travel
- X : Number of Lanes (Mixed Flow)



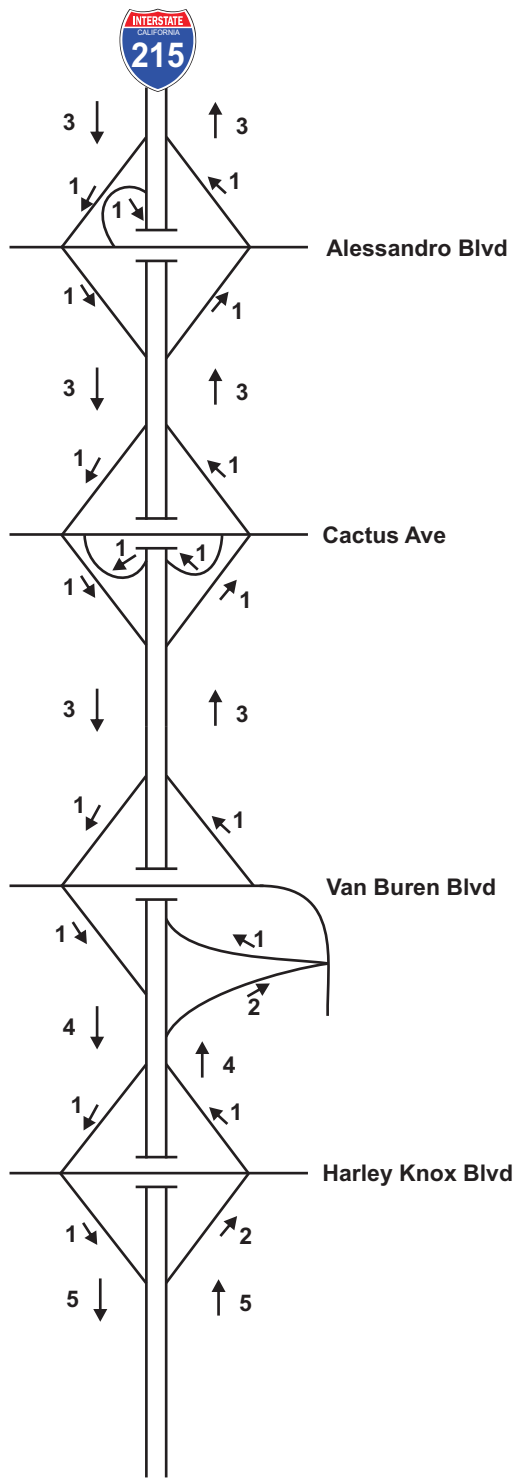

Note:
 One HOV Lane in each direction of travel will be provided in addition to the lanes indicated on I-215.

**Horizon Year (2040)
 Freeway Mainline Lane Geometry
 Interstate 215 - Alternative 4 Modified**

Figure 7-12a

Legend
 → Direction of Travel
 X : Number of Lanes (Mixed Flow)



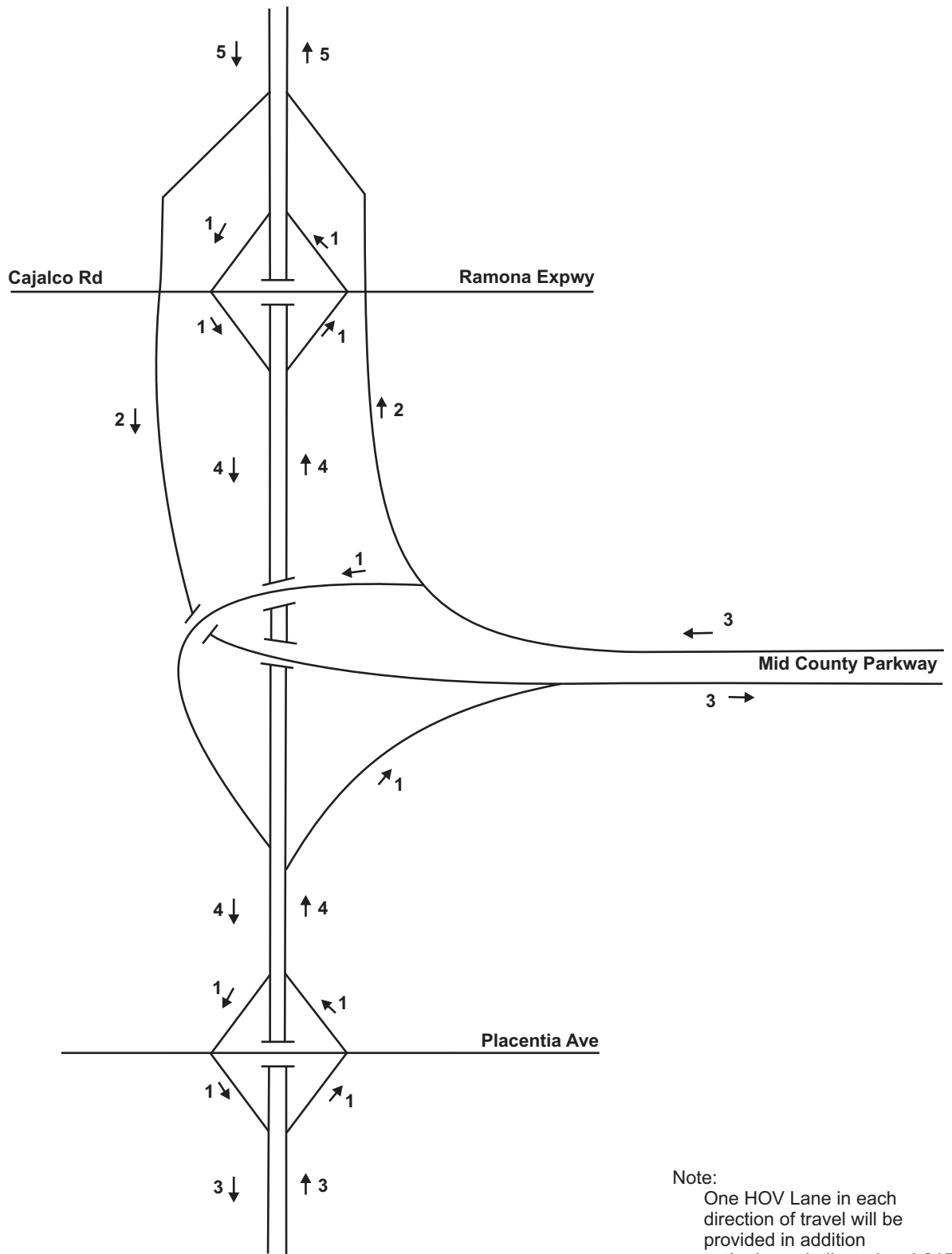

Note:
 One HOV Lane in each direction of travel will be provided in addition to the lanes indicated on I-215.

**Horizon Year (2040)
 Freeway Mainline Lane Geometry
 Interstate 215 - Alternative 4 Modified**

Figure 7-12b

Legend
 → Direction of Travel
 X : Number of Lanes (Mixed Flow)



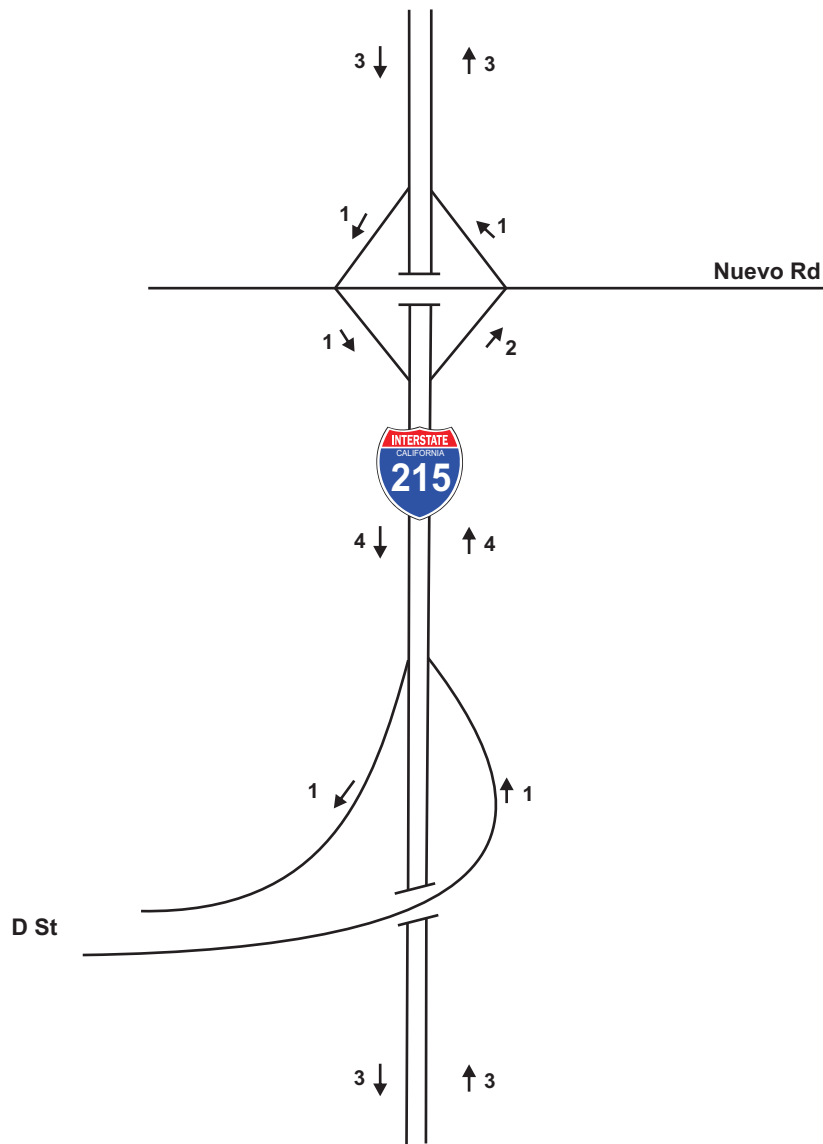

Note:
 One HOV Lane in each direction of travel will be provided North of Nuevo Rd in addition to the lanes indicated on I-215.

**Horizon Year (2040)
 Freeway Mainline Lane Geometry
 Interstate 215 - Alternative 4 Modified**

Figure 7-12c

Legend
 → Direction of Travel
 X : Number of Lanes (Mixed Flow)



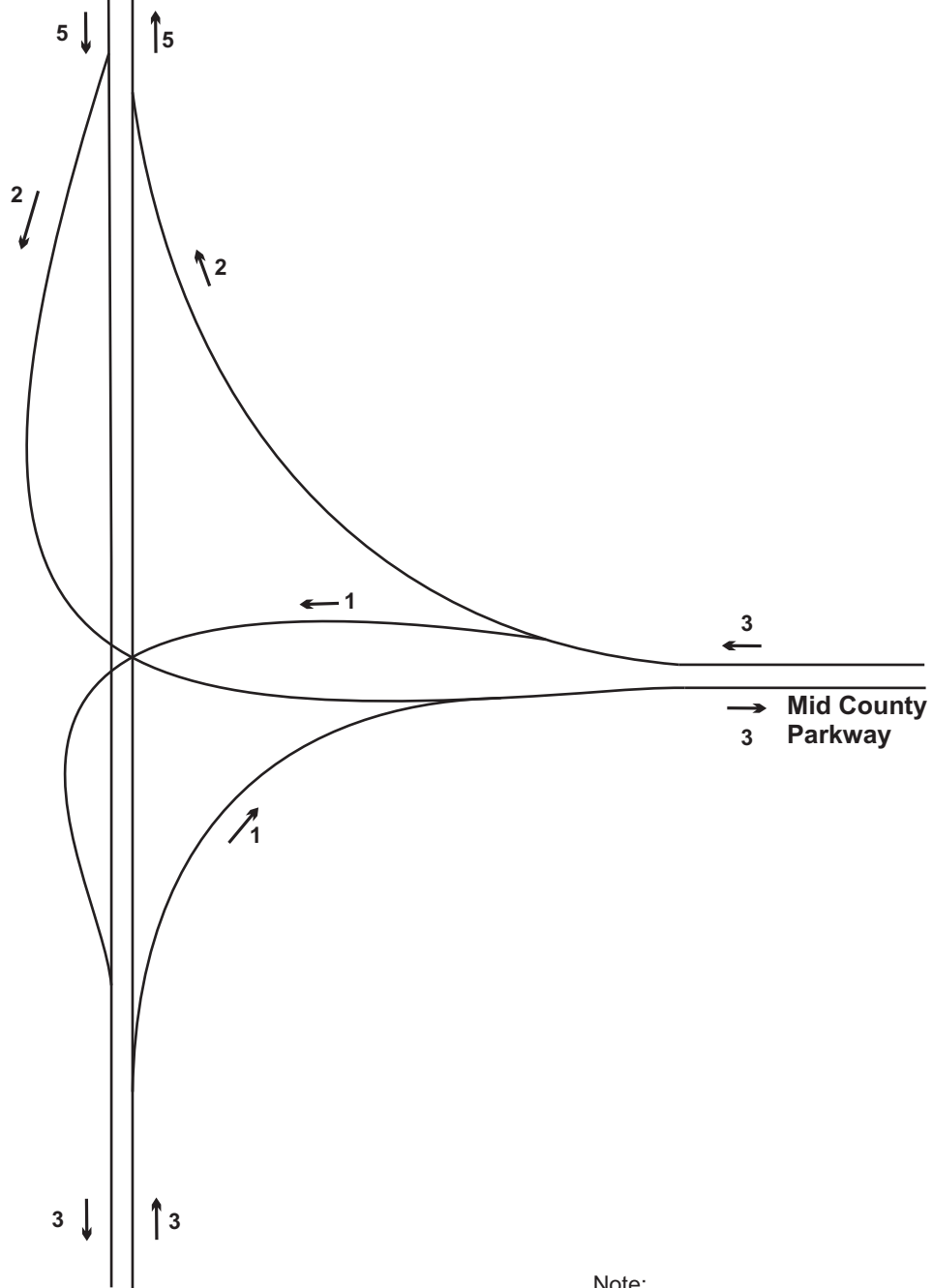

Note:
 One HOV Lane in each direction of travel will be provided in addition to the lanes indicated on I-215.

**Horizon Year (2040) MCP/I-215 Interchange Area
 Lane Geometry - Alternative 4 Modified**

Figure 7-13

Legend
 → Direction of Travel
 X : Number of Lanes (Mixed Flow)



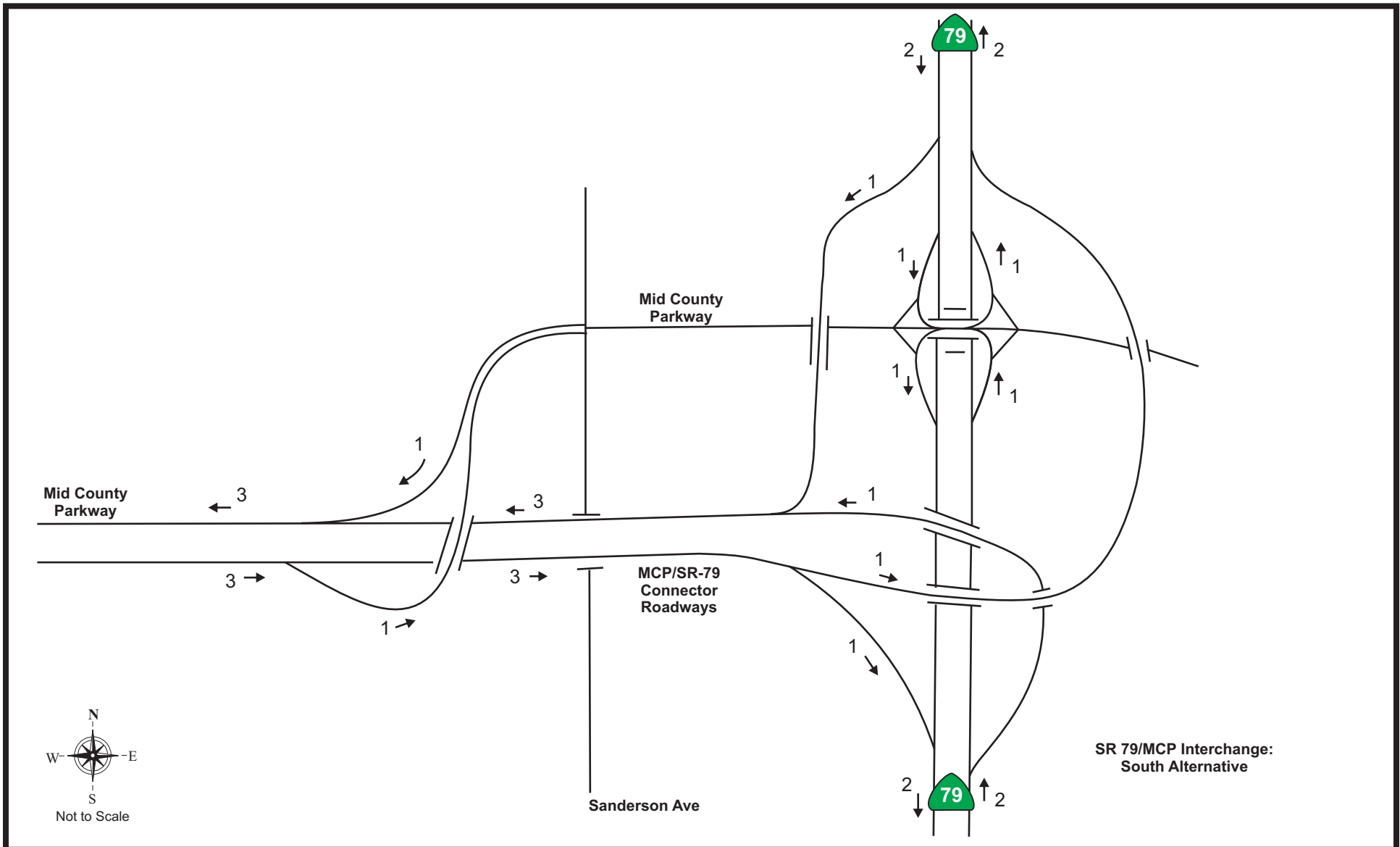

**Horizon Year (2040) MCP/SR-79 Interchange Area
Lane Geometry - Alternative 4 Modified**

Figure 7-14

Legend

← Number of Lanes
X



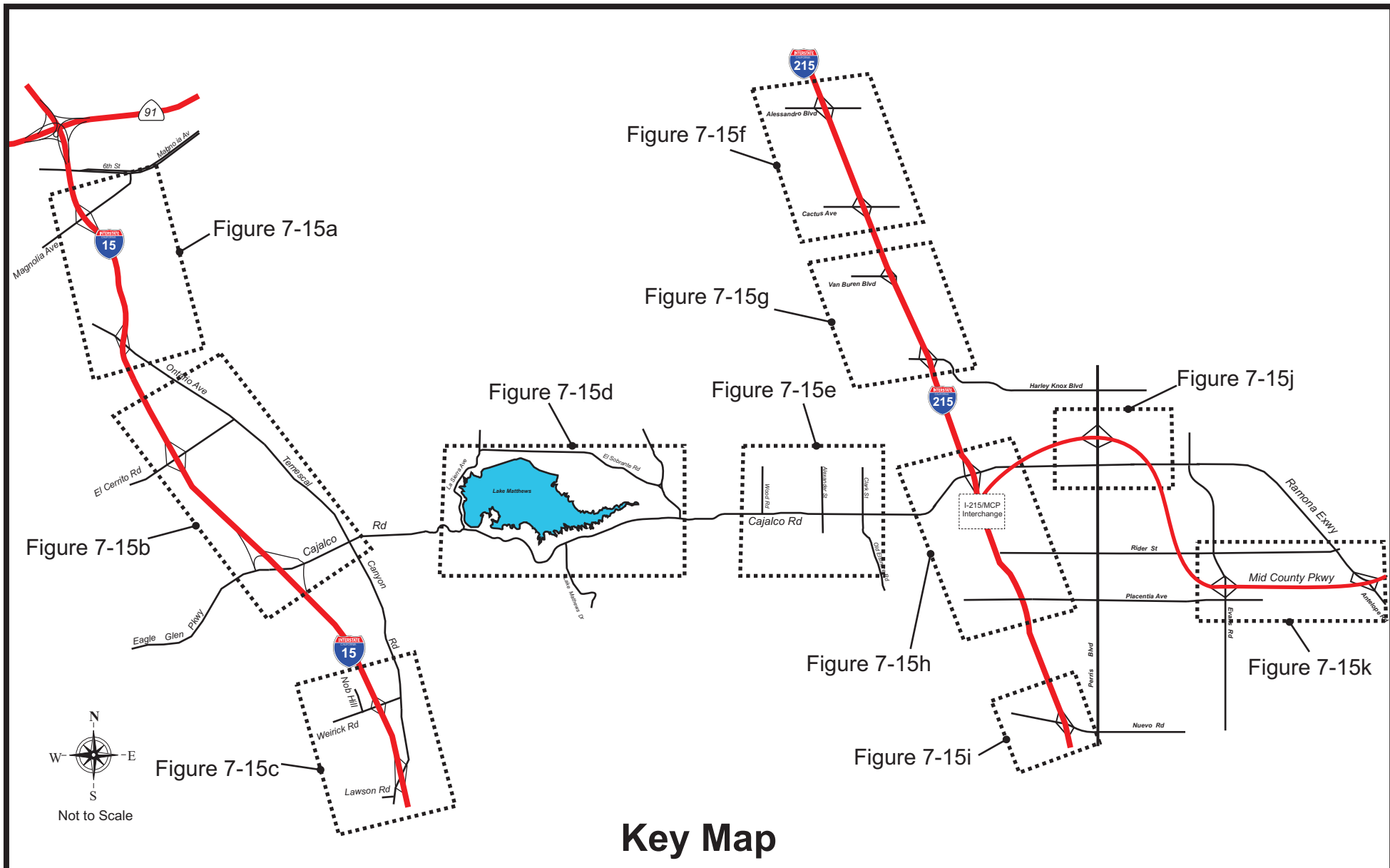

**Horizon Year (2040) Intersection Lane Geometry
Alternative 4 Modified**

Figure 7-15

Legend:

 Figure Areas



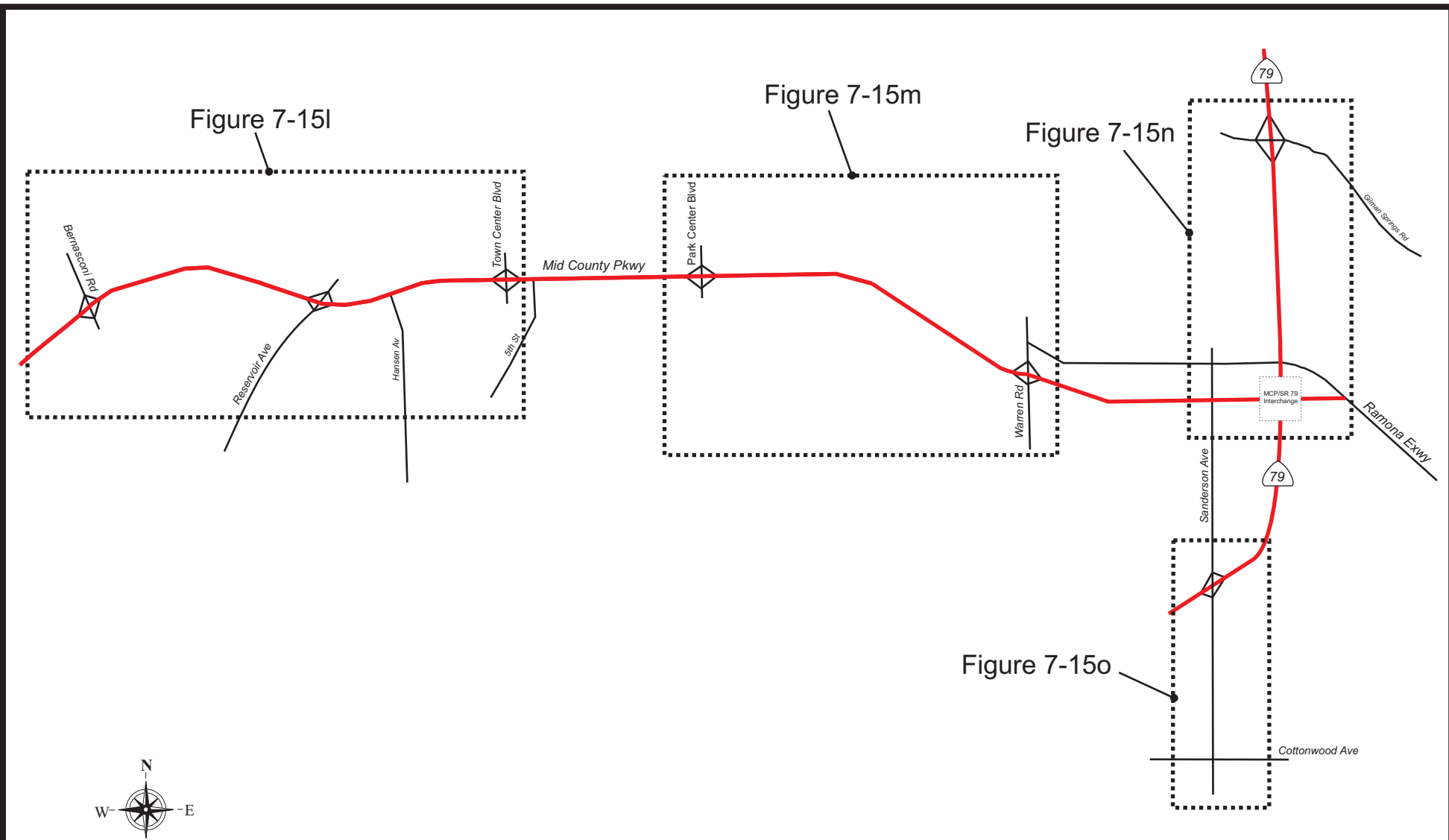

Key Map

**Horizon Year (2040) Intersection Lane Geometry
Alternative 4 Modified**

Figure 7-15 (cont.)

Legend:

 Figure Areas



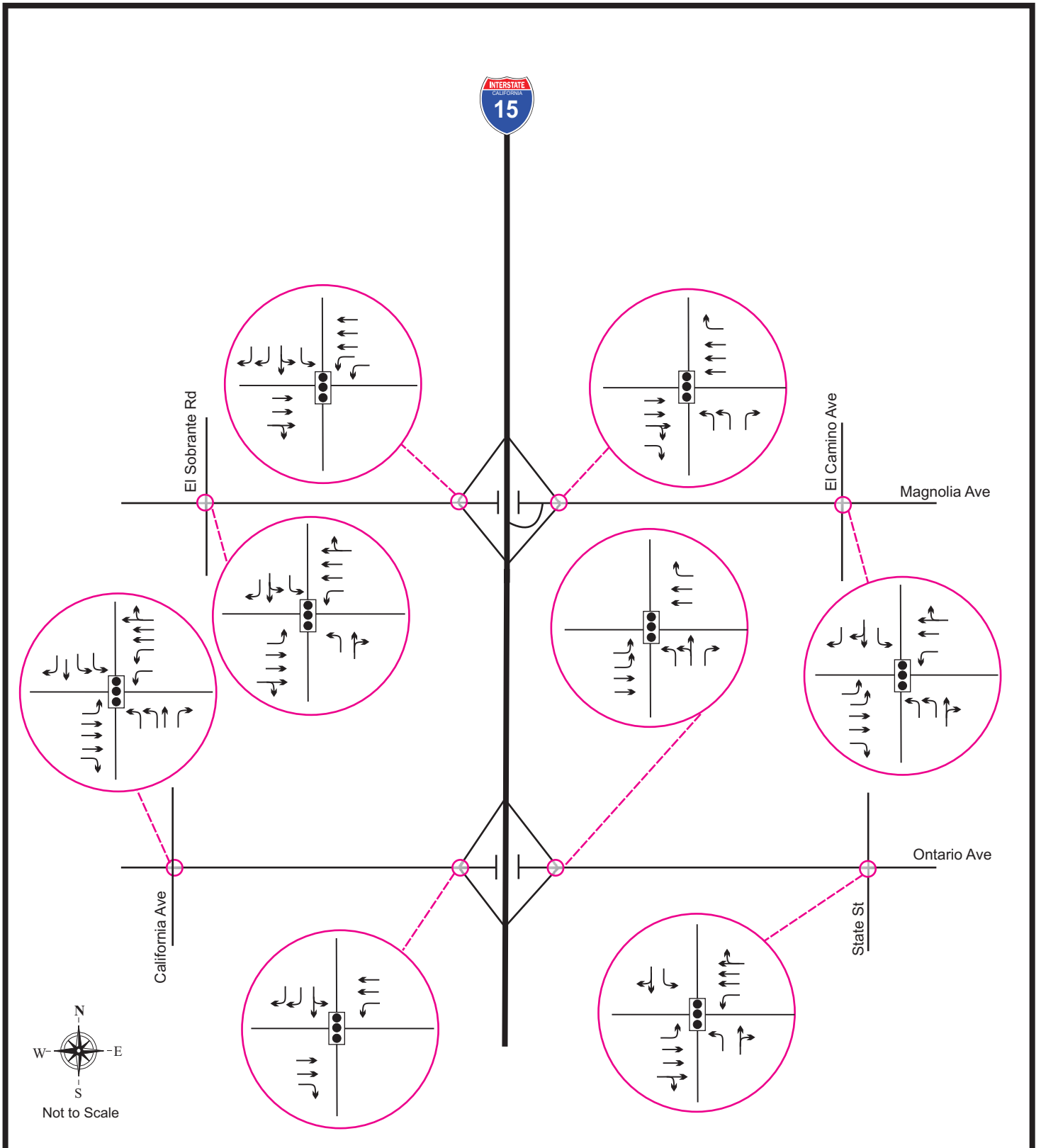

**Horizon Year (2040) Intersection
Lane Geometry - Alternative 4 Modified**

Figure 7-15a

Legend:



Signal



Traffic Lane



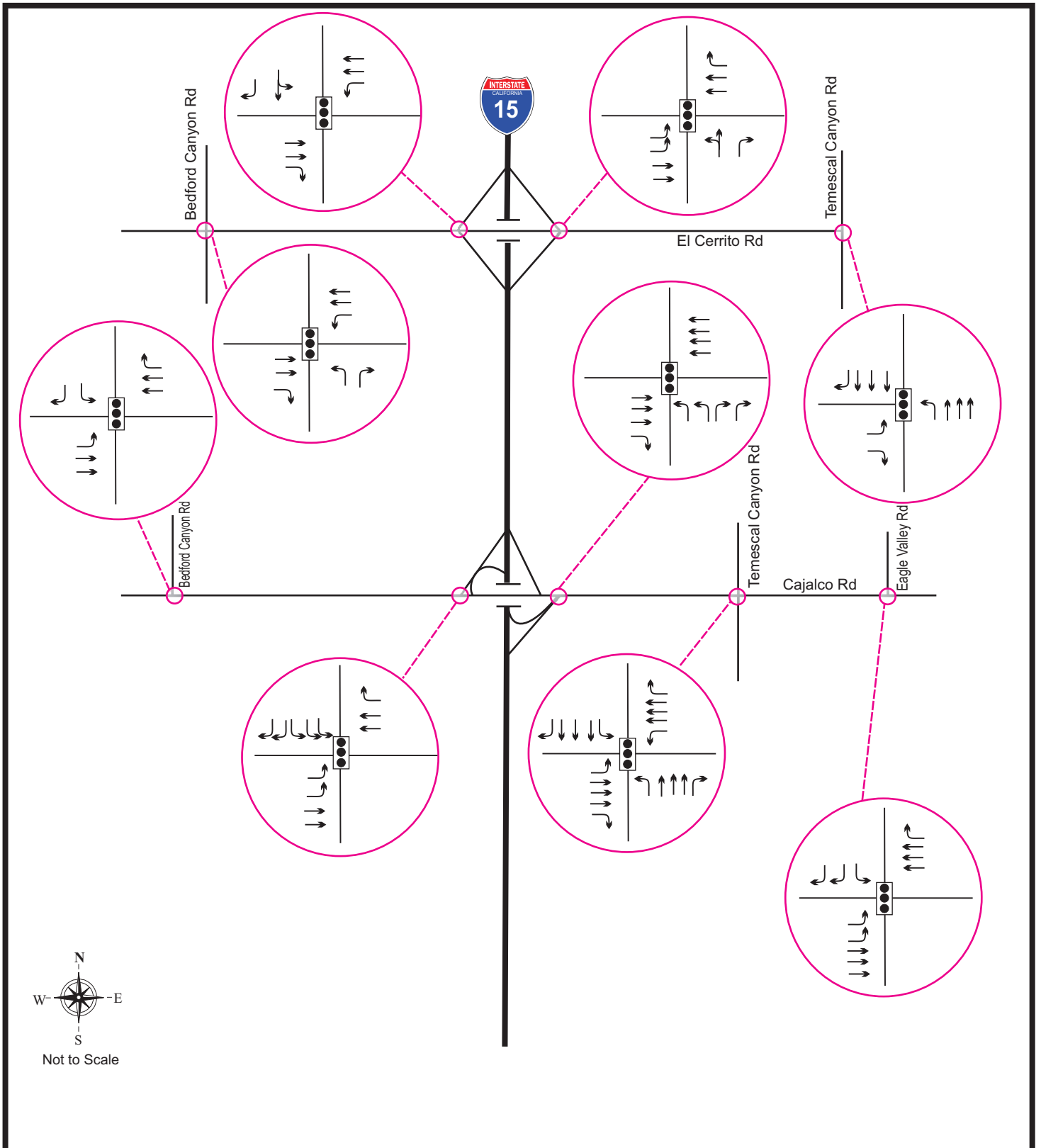

**Horizon Year (2040) Intersection
Lane Geometry - Alternative 4 Modified**

Figure 7-15b

Legend:



Signal



Traffic Lane



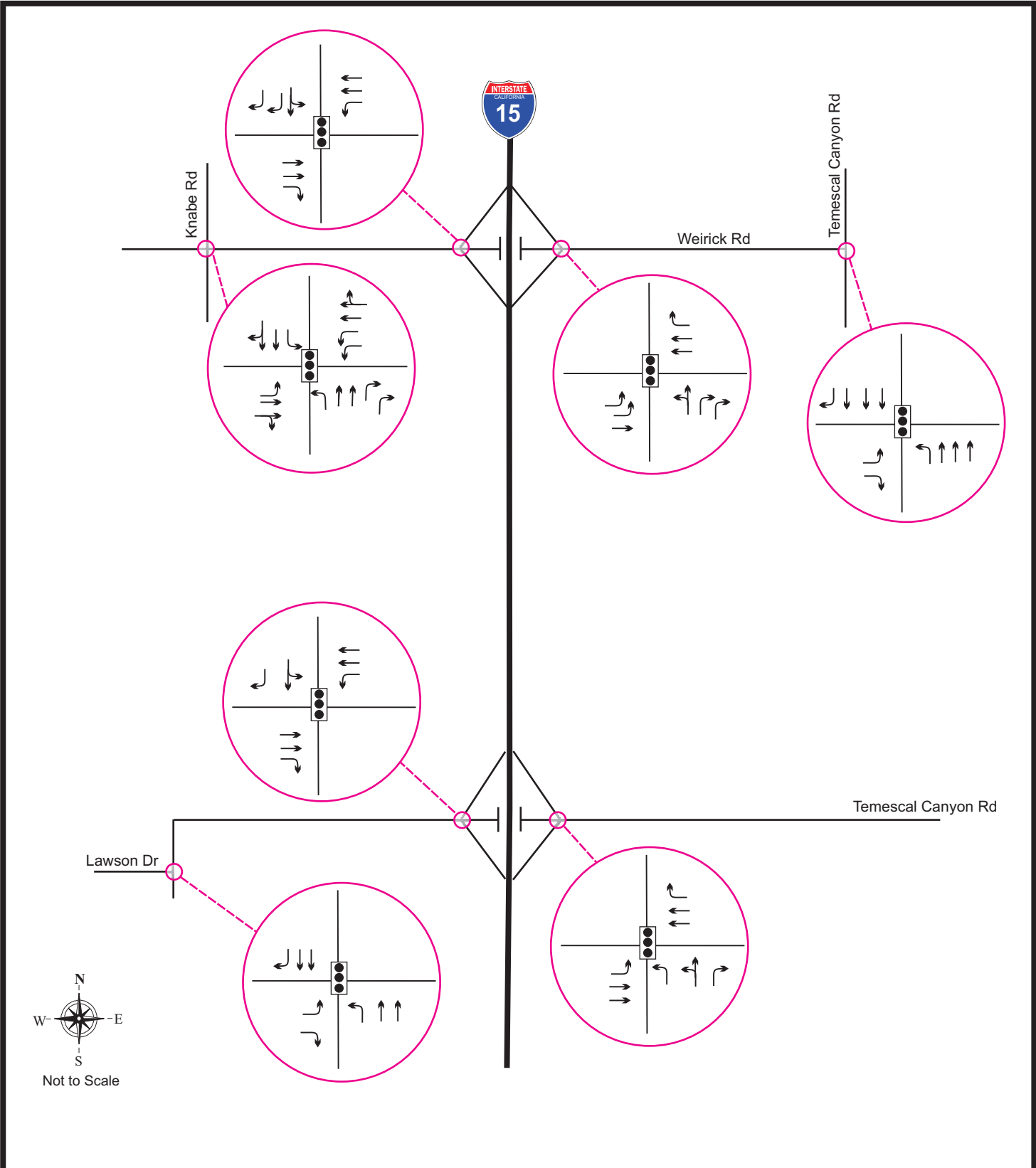

**Horizon Year (2040) Intersection
Lane Geometry - Alternative 4 Modified**

Figure 7-15c

Legend:

-  Signal
-  Traffic Lane



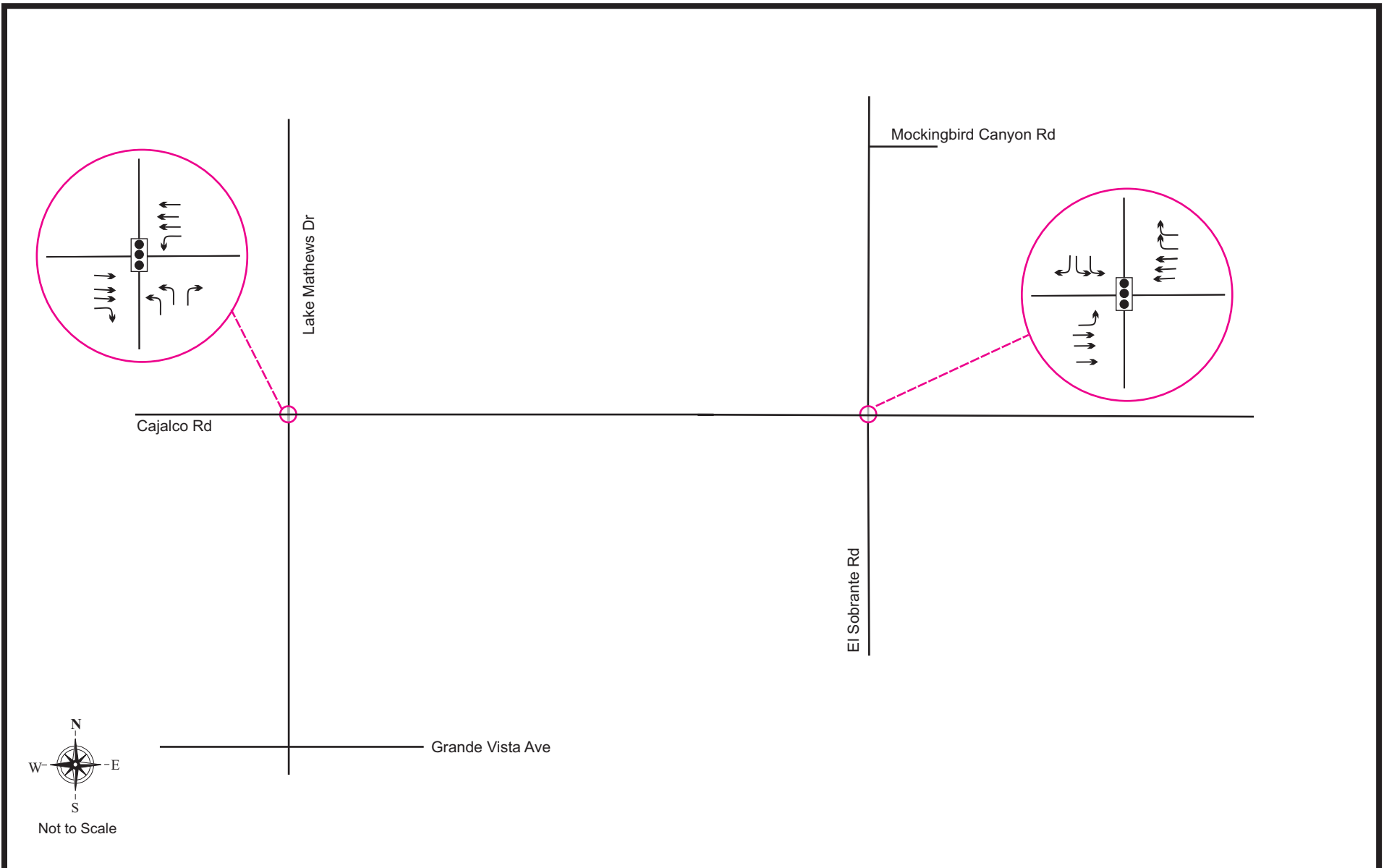

**Horizon Year (2040) Intersection
Lane Geometry - Alternative 4 Modified**

Figure 7-15d

Legend:

-  Signal
-  Traffic Lane



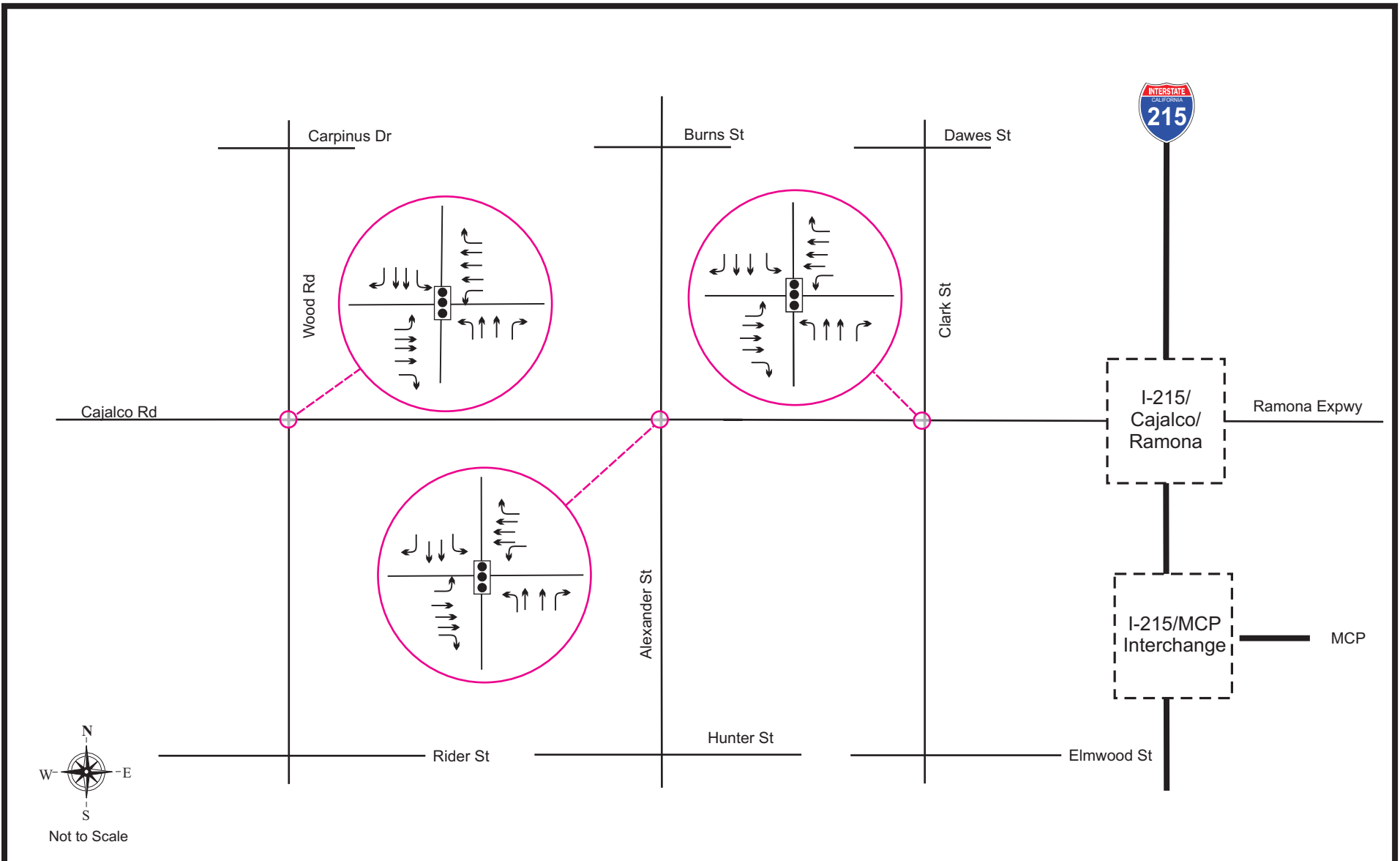

**Horizon Year (2040) Intersection
Lane Geometry - Alternative 4 Modified**

Figure 7-15e

Legend:

-  Signal
-  Traffic Lane



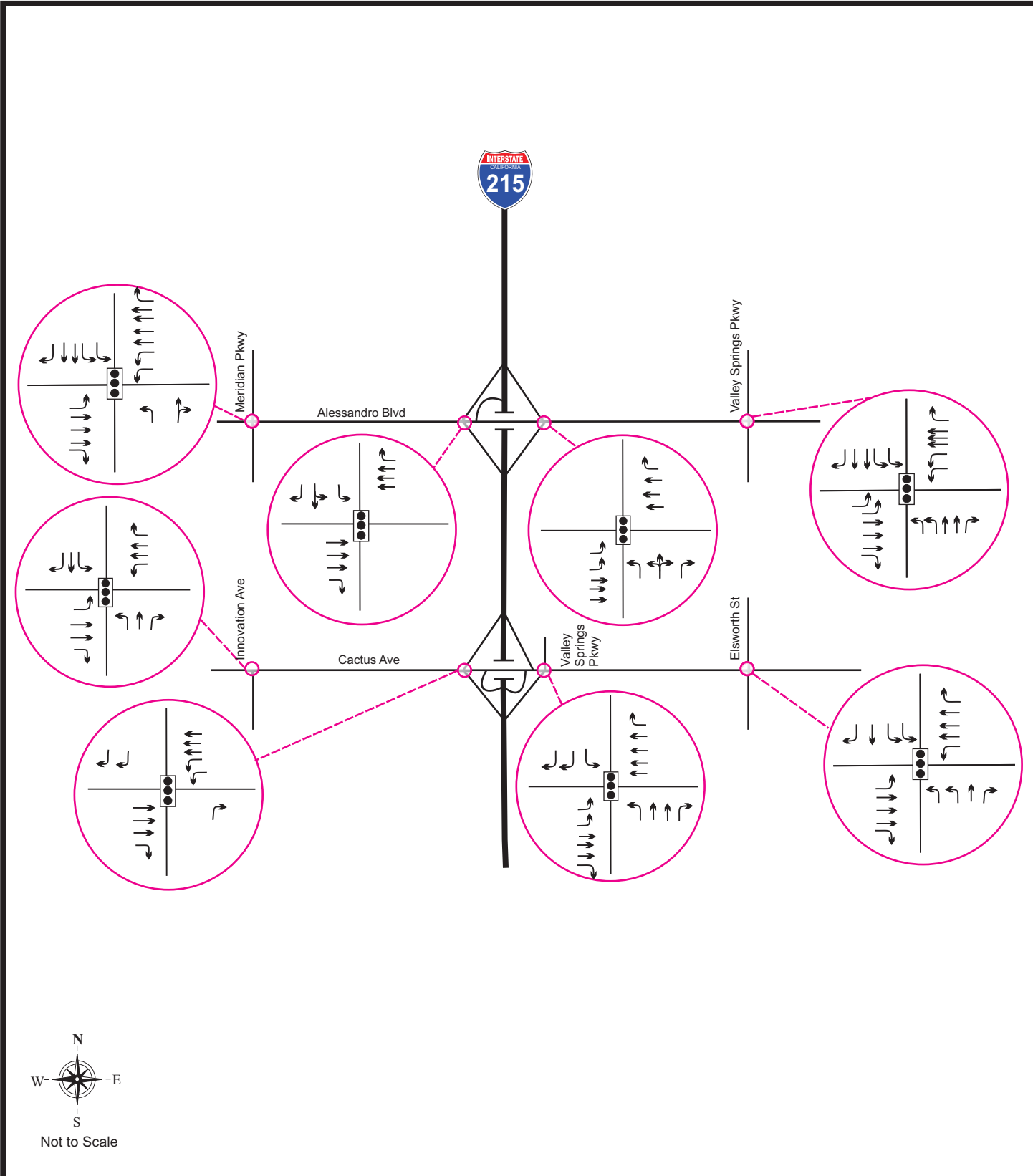

**Horizon Year (2040) Intersection
Lane Geometry - Alternative 4 Modified**

Figure 7-15f

Legend:

-  Signal
-  Traffic Lane



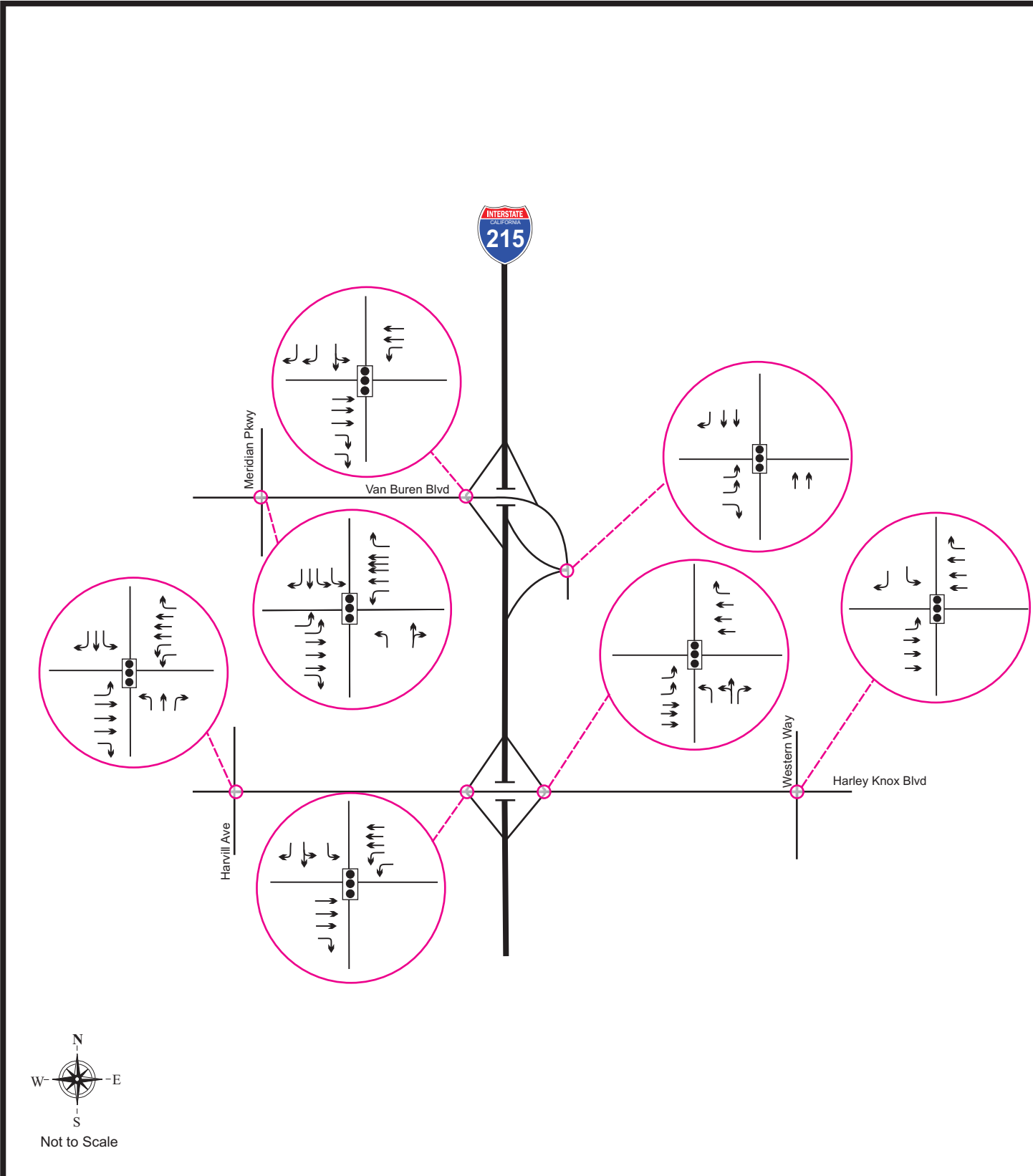

**Horizon Year (2040) Intersection
Lane Geometry - Alternative 4 Modified**

Figure 7-15g

Legend:

-  Signal
-  Traffic Lane



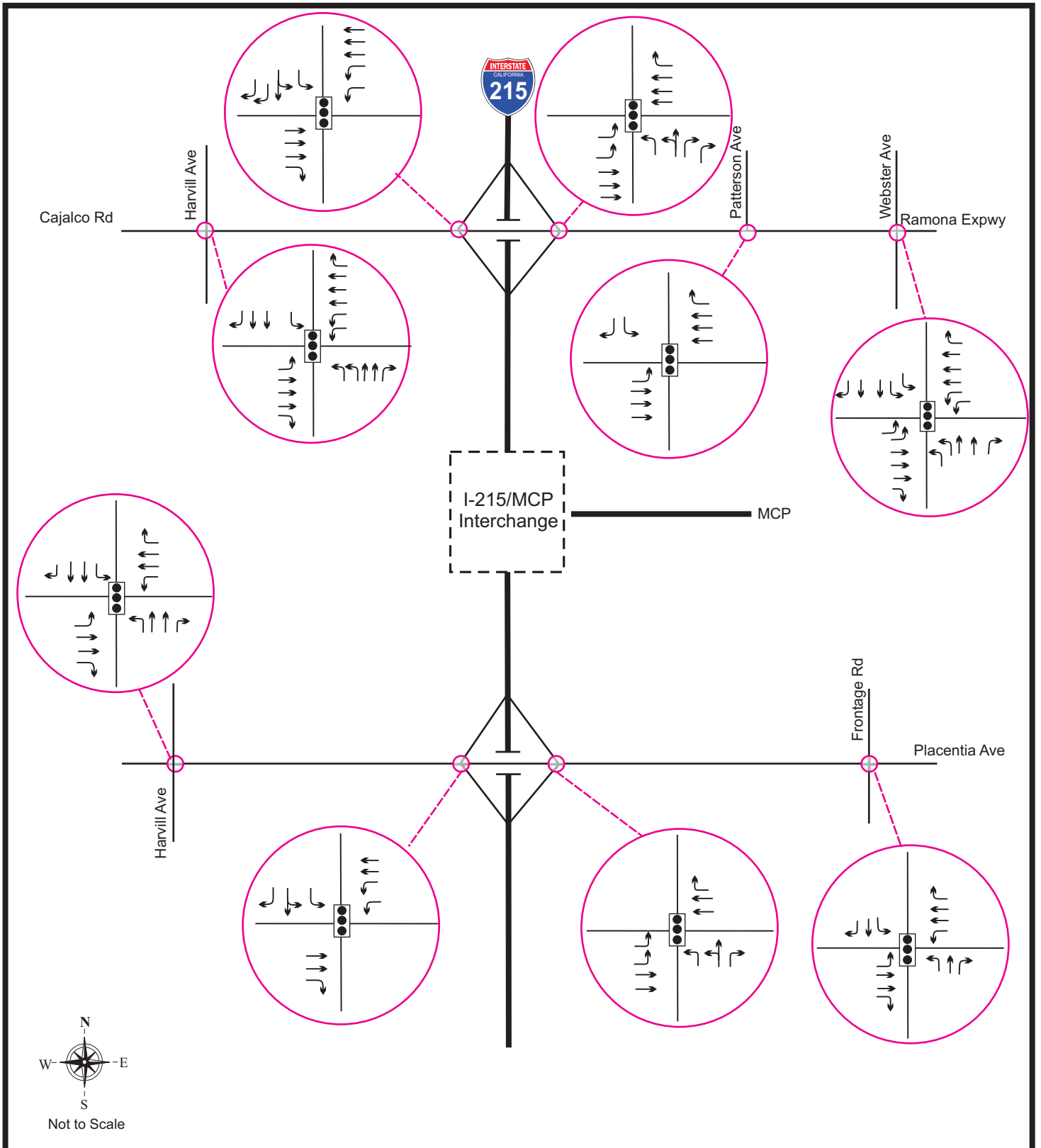

**Horizon Year (2040) Intersection
Lane Geometry - Alternative 4 Modified**

Figure 7-15h

Legend:



Signal



Traffic Lane



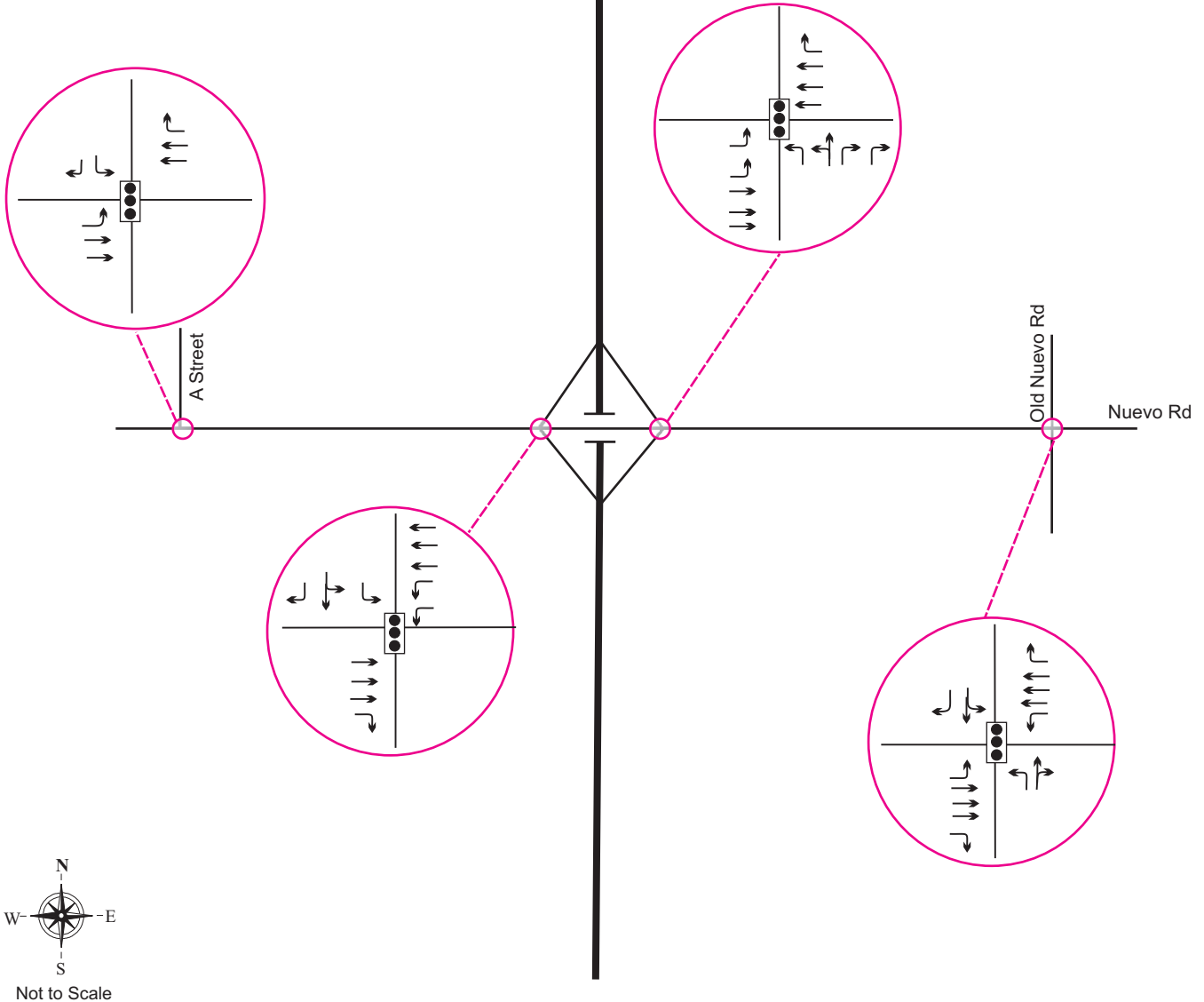

**Horizon Year (2040) Intersection
Lane Geometry - Alternative 4 Modified**

Figure 7-15i

Legend:



Signal



Traffic Lane



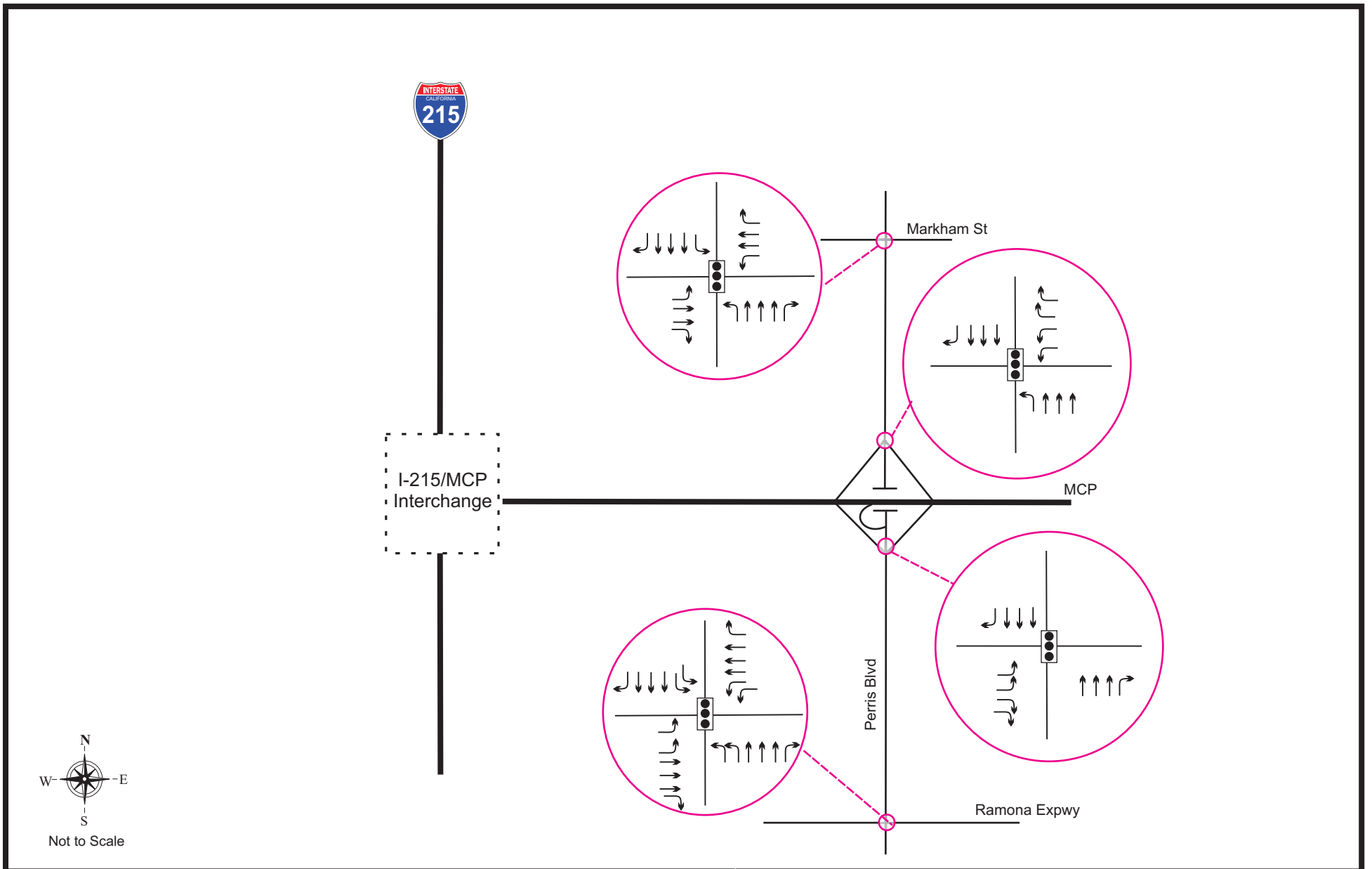

**Horizon Year (2040) Intersection
Lane Geometry - Alternative 4 Modified**

Figure 7-15j

Legend:

-  Signal
-  Traffic Lane



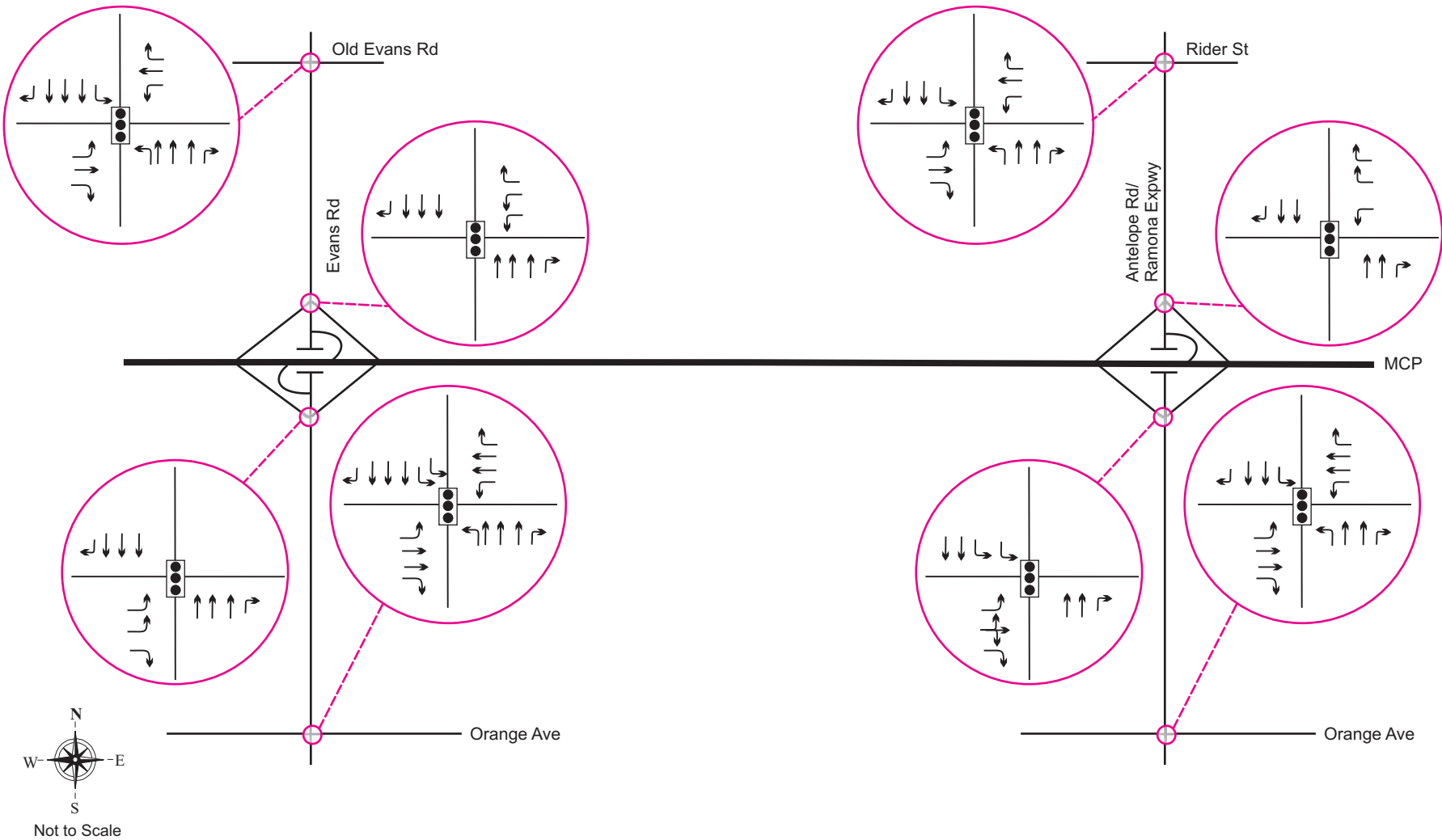

**Horizon Year (2040) Intersection
Lane Geometry - Alternative 4 Modified**

Figure 7-15k

Legend:

-  Signal
-  Traffic Lane



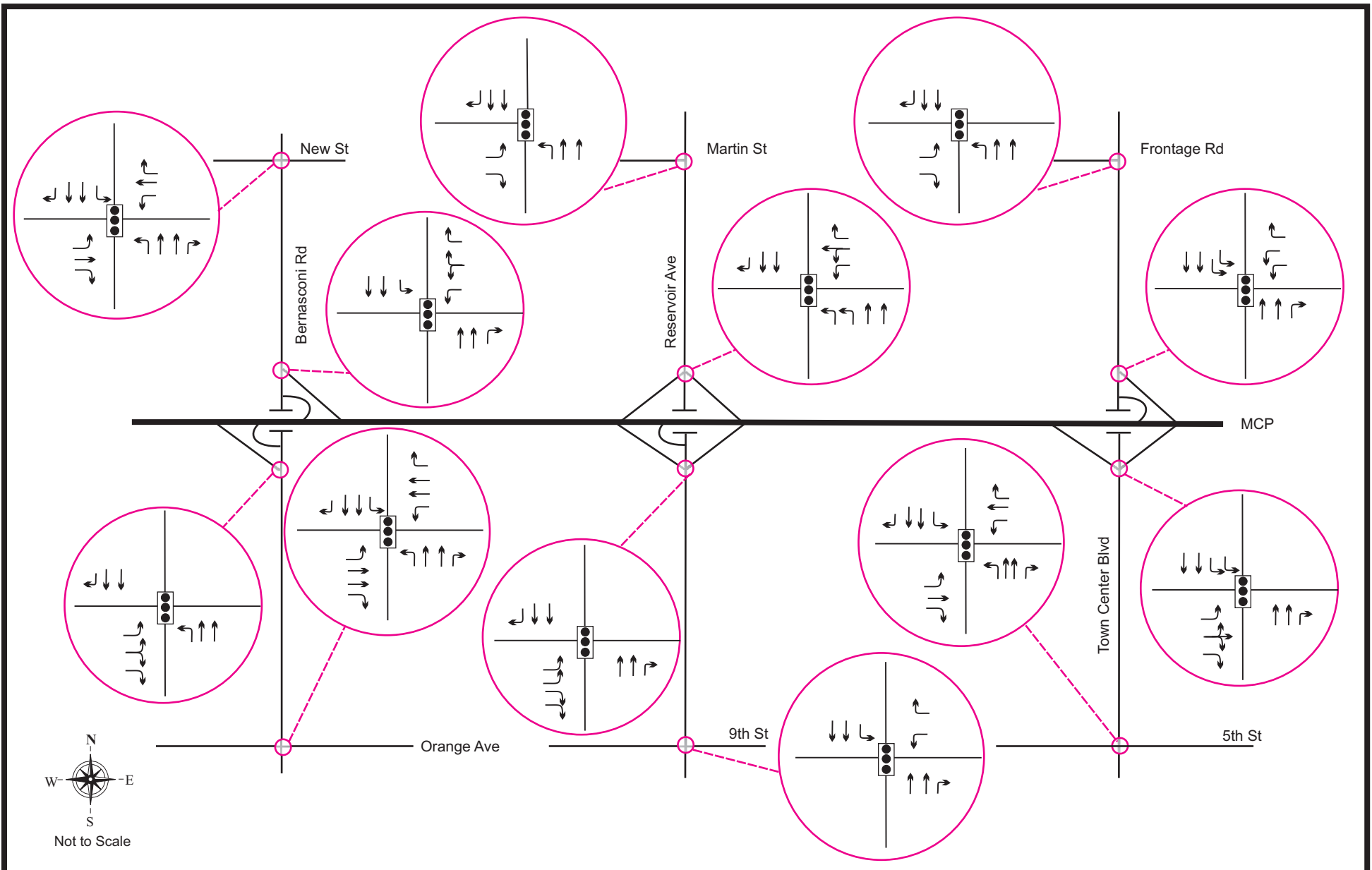

**Horizon Year (2040) Intersection
Lane Geometry - Alternative 4 Modified**

Figure 7-15I

Legend:

-  Signal
-  Traffic Lane



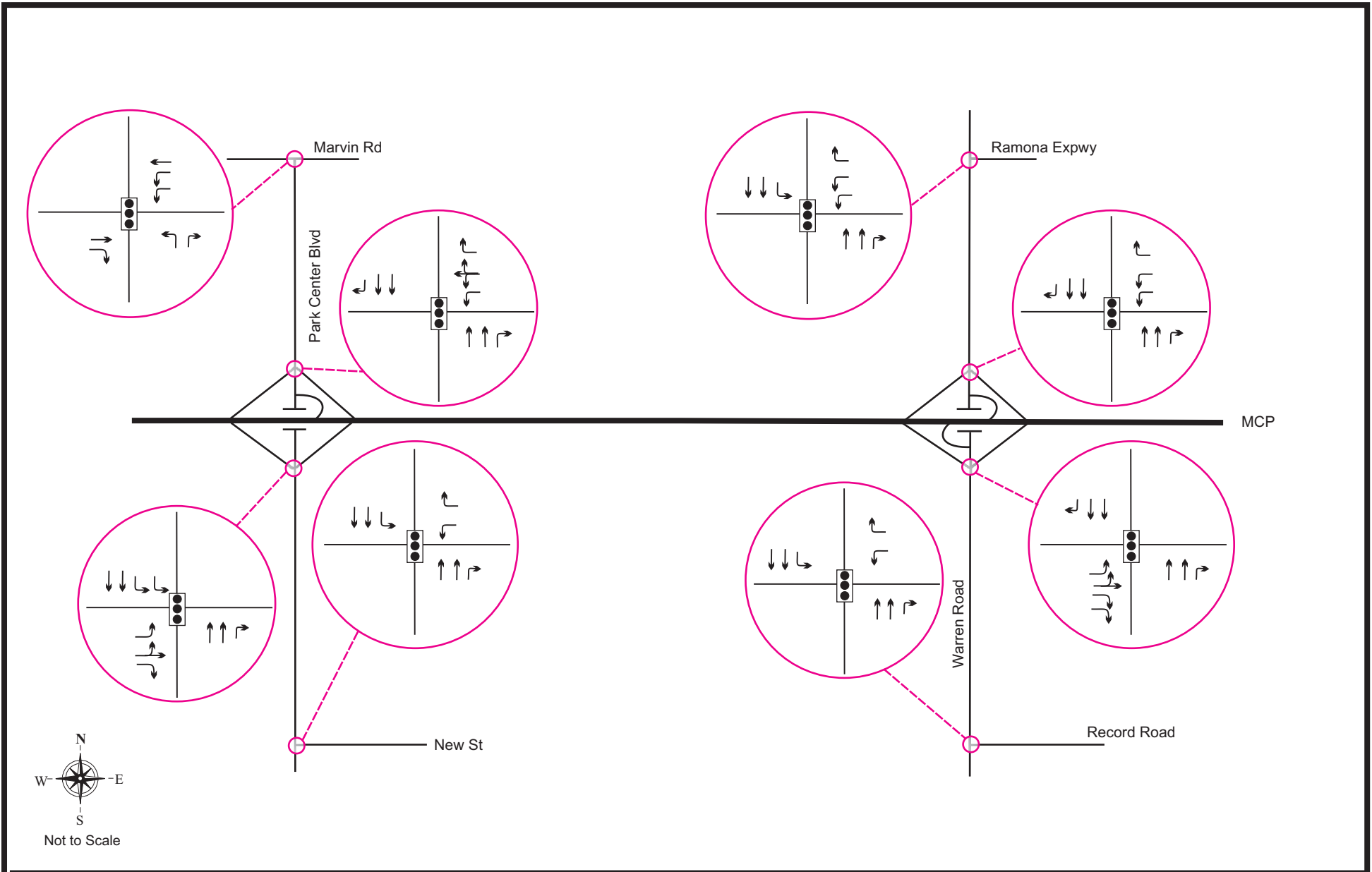

**Horizon Year (2040) Intersection
Lane Geometry - Alternative 4 Modified**

Figure 7-15m

Legend:

-  Signal
-  Traffic Lane



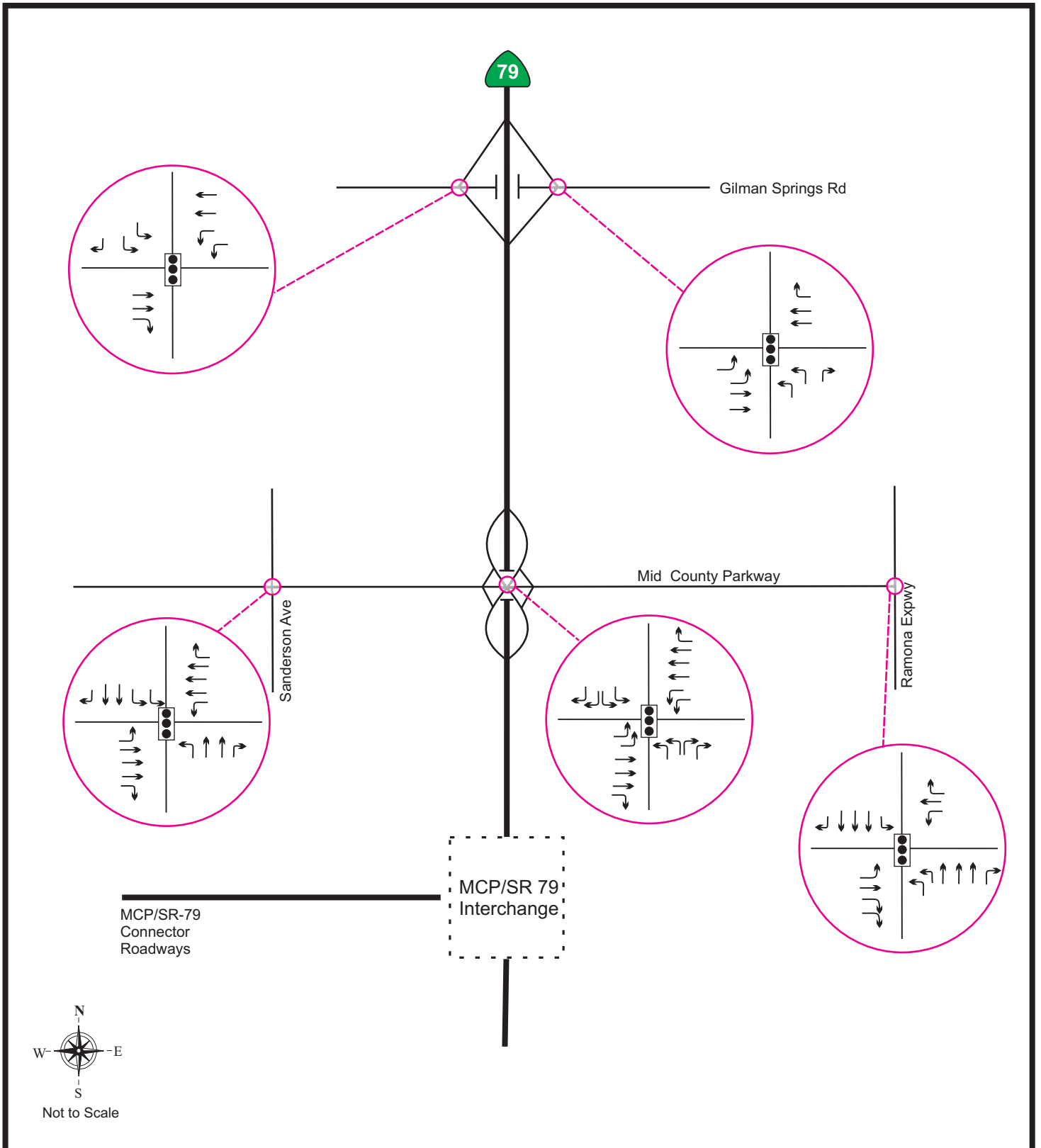

Horizon Year (2040) Intersection Lane Geometry - Alternative 4 Modified

Figure 7-15n



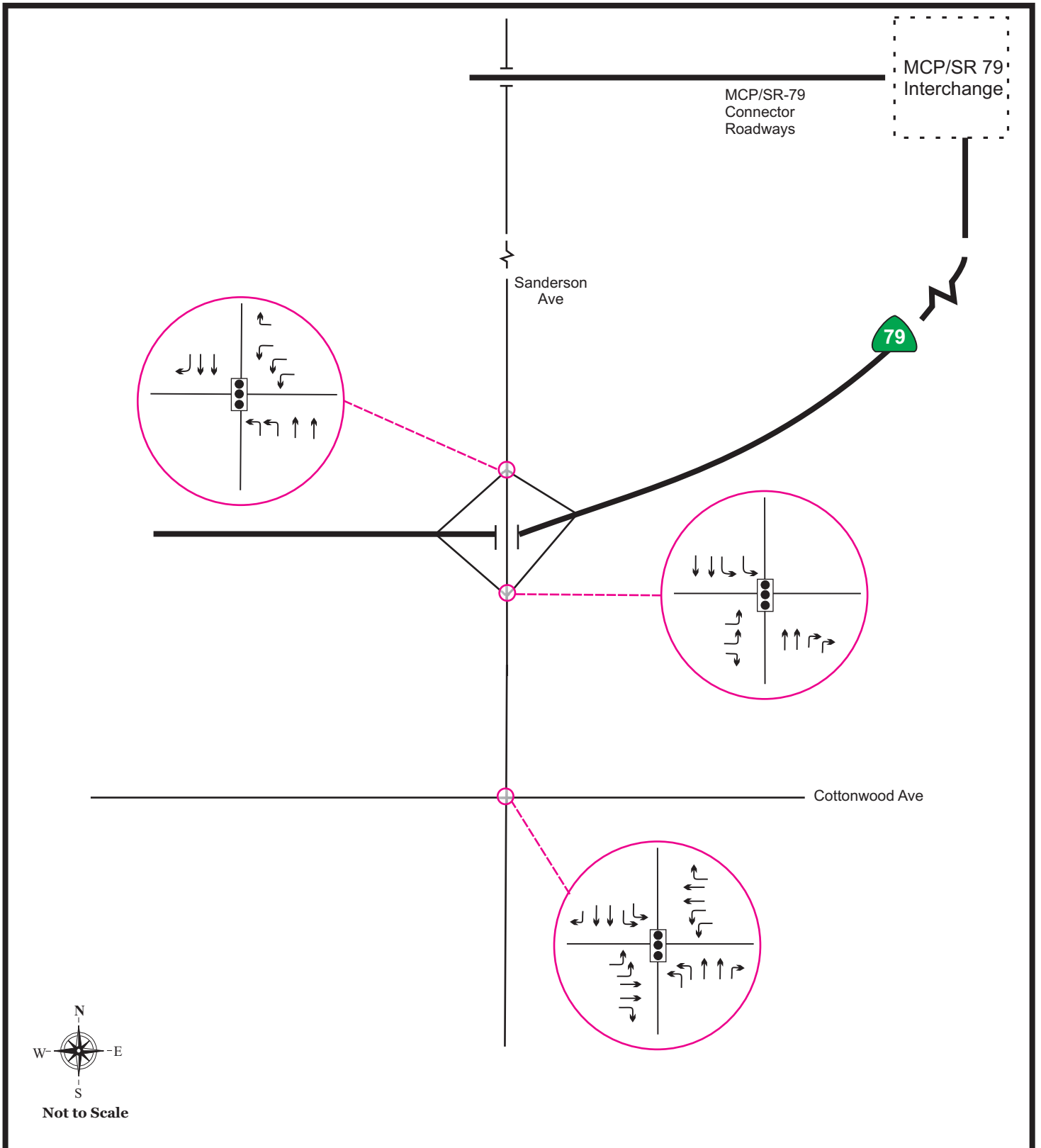

**Horizon Year (2040) Intersection
Lane Geometry - Alternative 4 Modified**

Figure 7-15o

Legend:



Signal



Traffic Lane



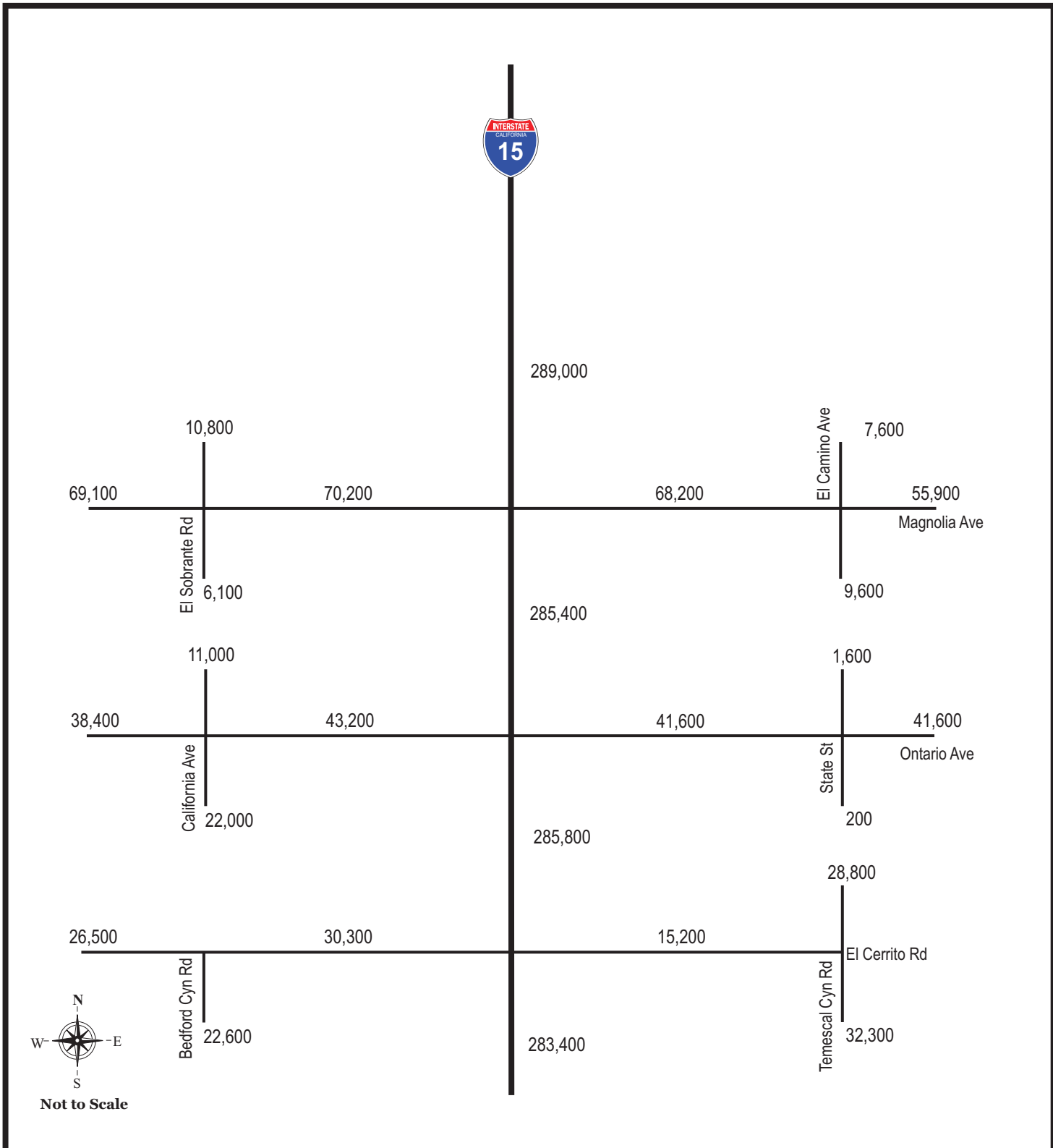

Horizon Year (2040) ADT - Freeway and Street Segments MCP Area - Alternative 4 Modified

Figure 7-16a

Legend:

XX,XXX Average Daily Traffic



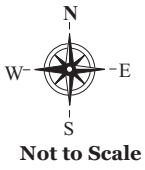
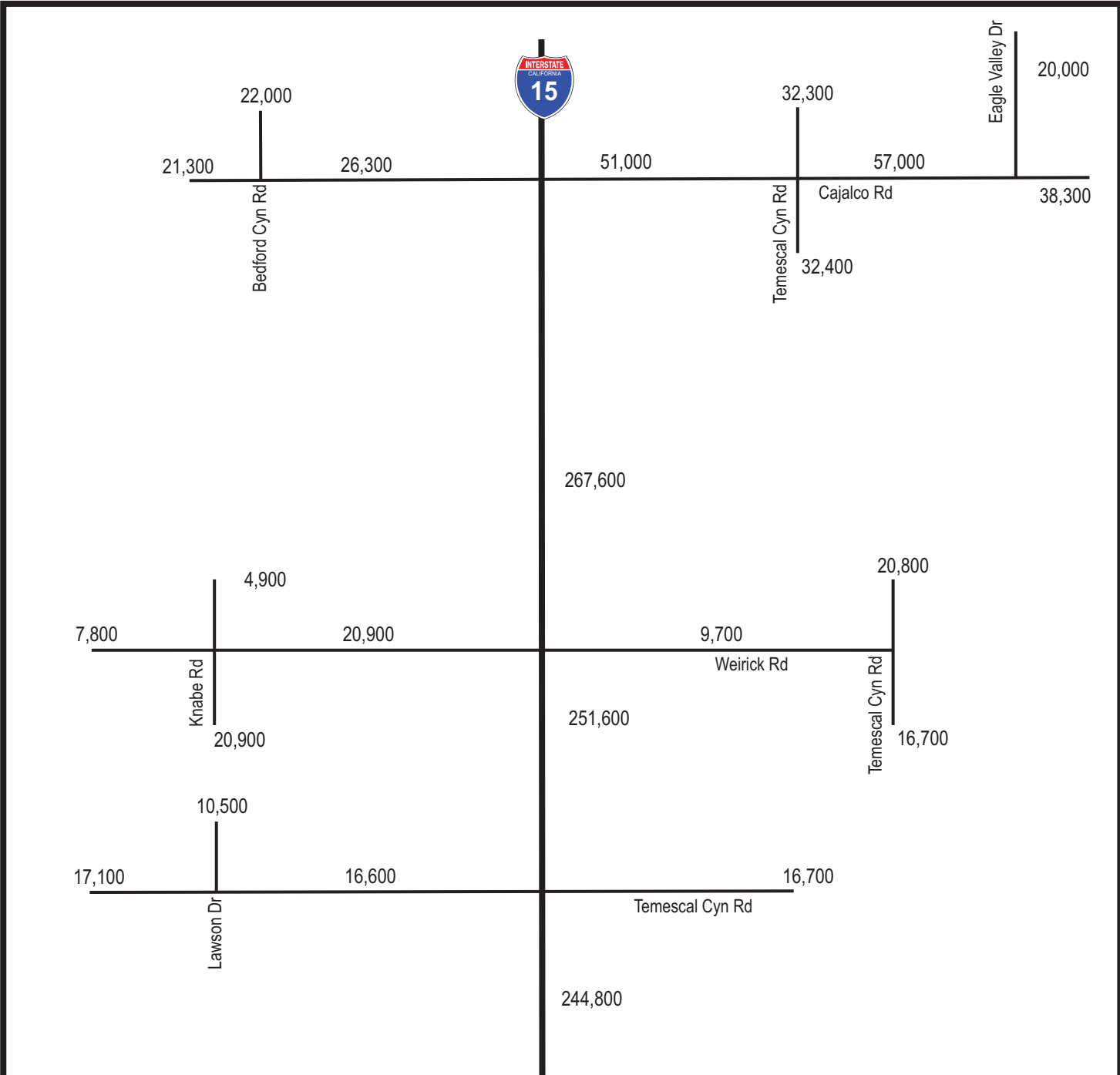

Horizon Year (2040) ADT - Freeway and Street Segments MCP Area - Alternative 4 Modified

Figure 7-16b

Legend:
 XX,XXX Average Daily Traffic



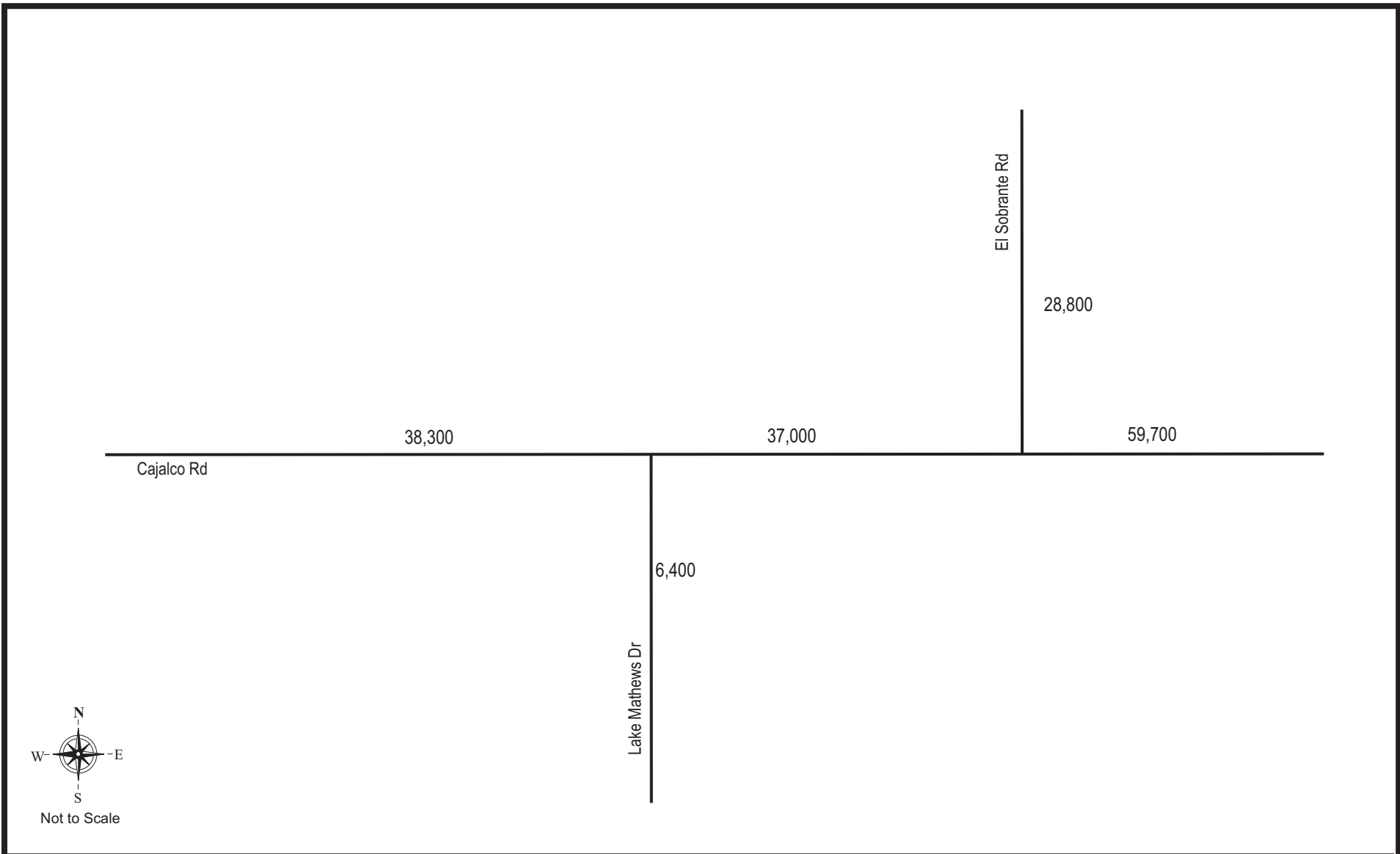

Horizon Year (2040) ADT - Freeway and Street Segments MCP Area - Alternative 4 Modified

Figure 7-16c

Legend:

XX,XXX Average Daily Traffic



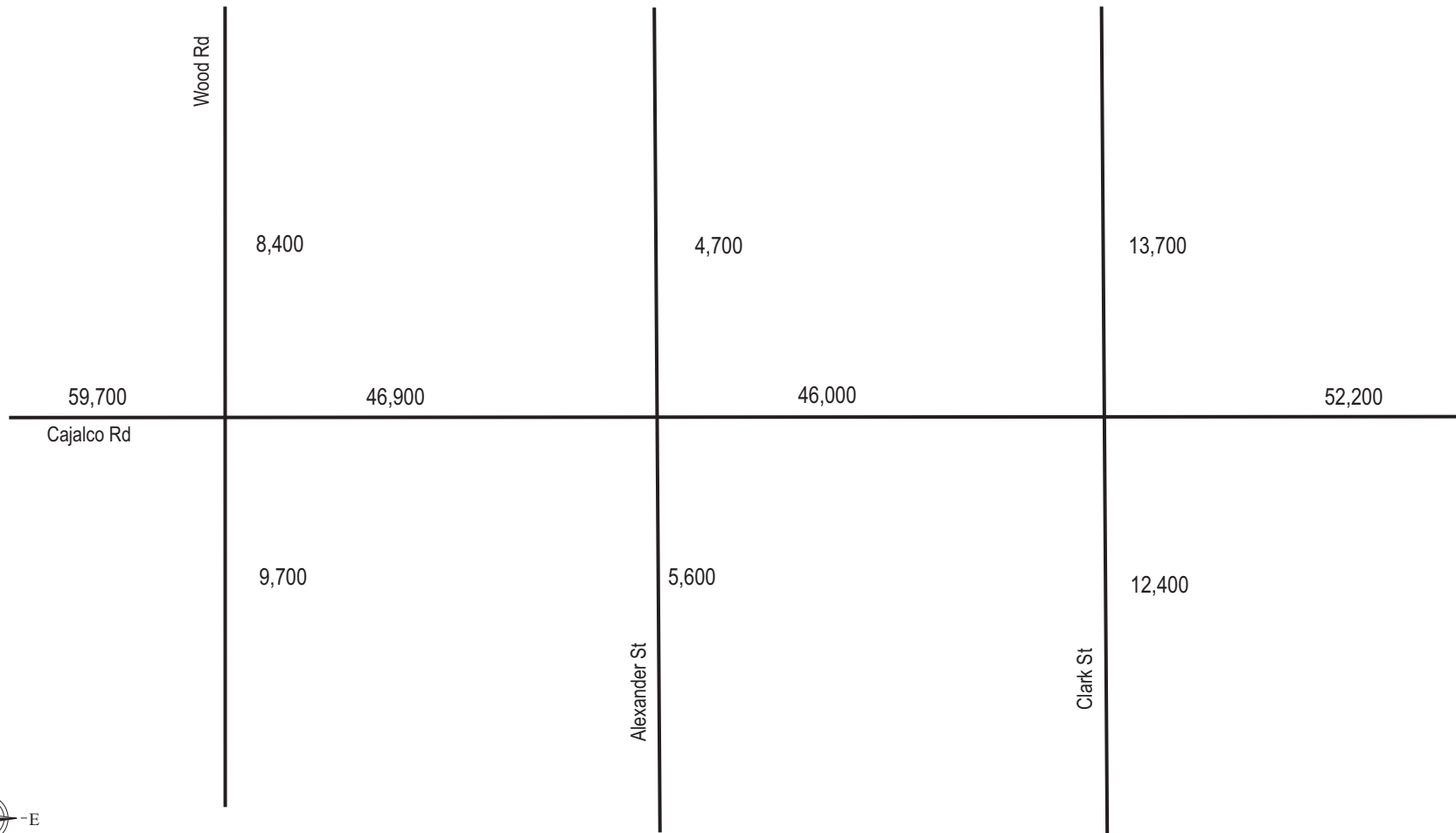

Horizon Year (2040) ADT - Freeway and Street Segments MCP Area - Alternative 4 Modified

Figure 7-16d

Legend:

XX,XXX Average Daily Traffic



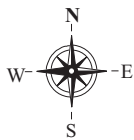
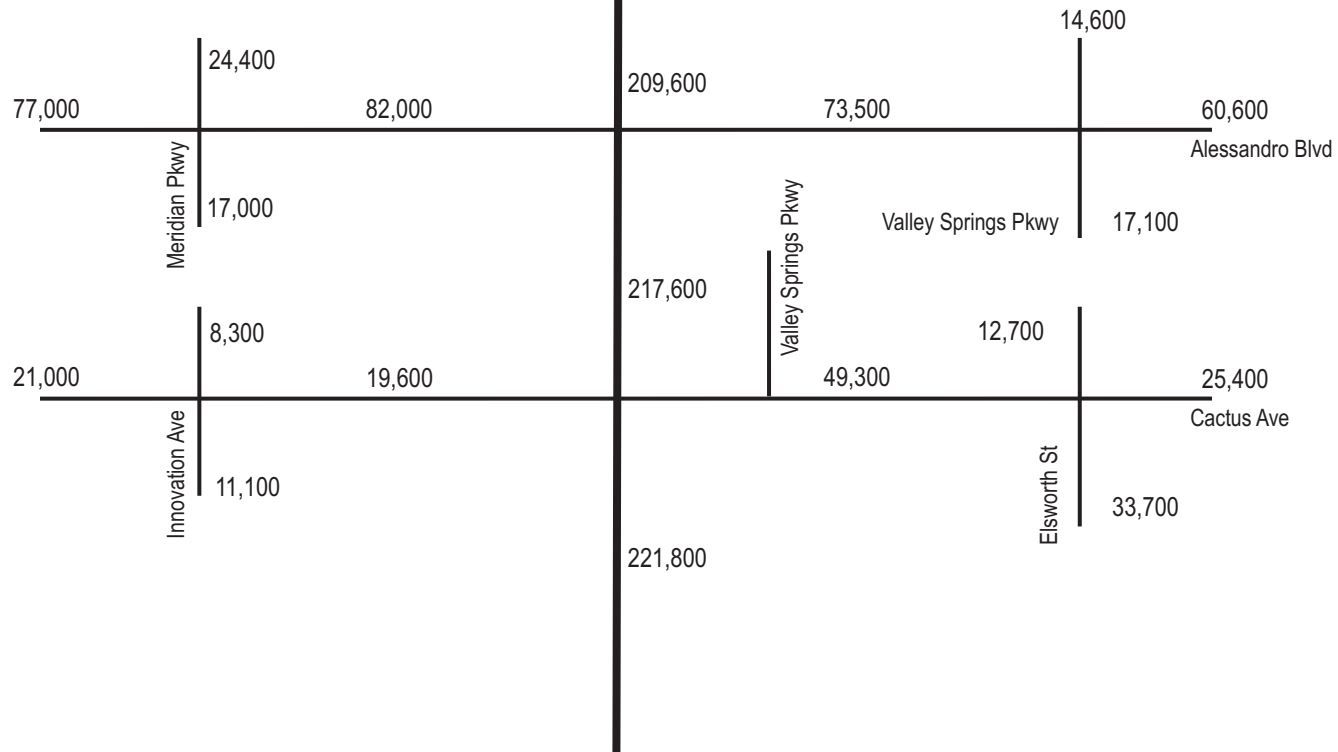

Not to Scale

Horizon Year (2040) ADT - Freeway and Street Segments MCP Area - Alternative 4 Modified

Figure 7-16e

Legend:

XX,XXX Average Daily Traffic





Not to Scale

Horizon Year (2040) ADT - Freeway and Street Segments MCP Area - Alternative 4 Modified

Figure 7-16f

Legend:

XX,XXX Average Daily Traffic



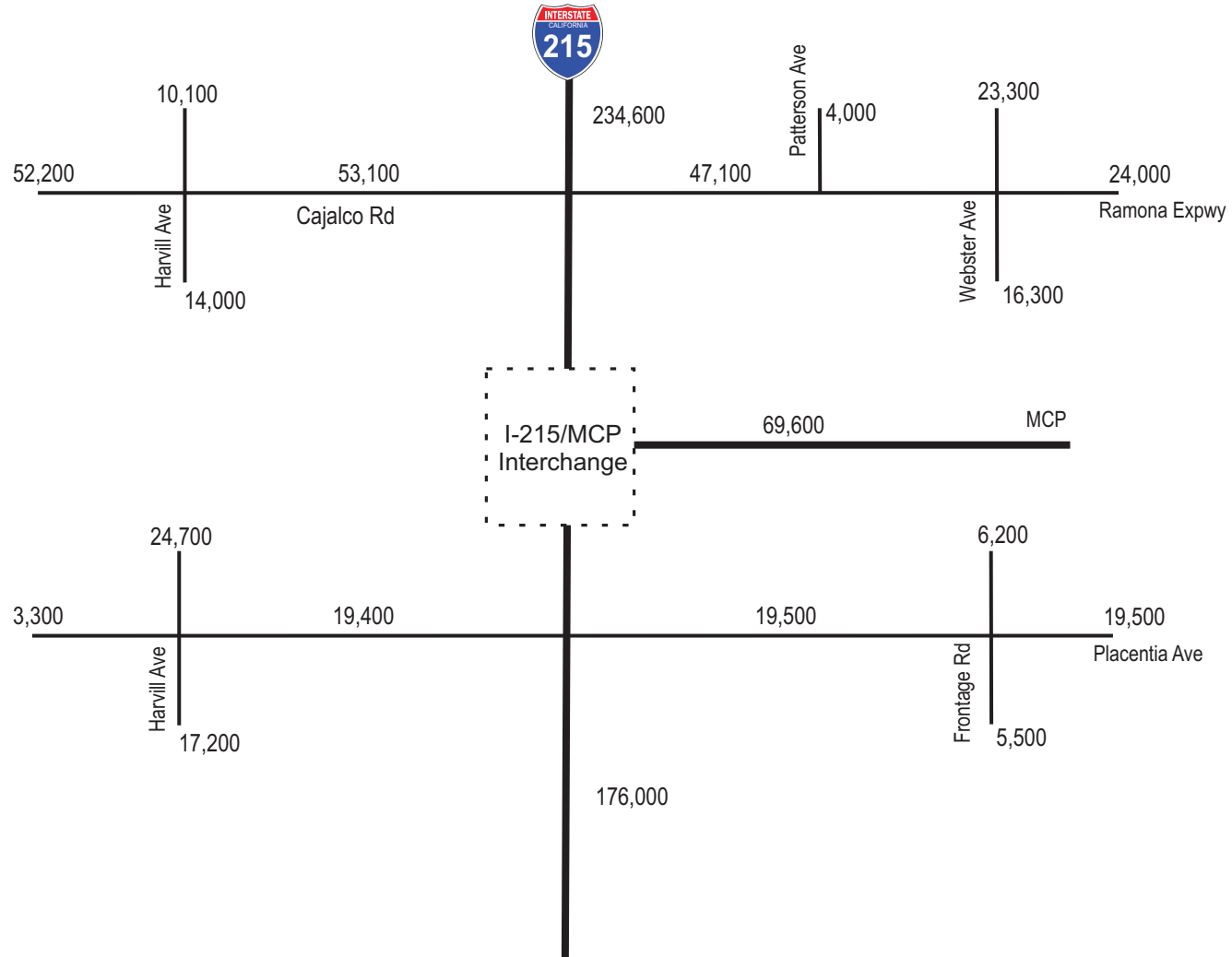

Horizon Year (2040) ADT - Freeway and Street Segments MCP Area - Alternative 4 Modified

Figure 7-16g

Legend:

XX,XXX Average Daily Traffic





Not to Scale

Horizon Year (2040) ADT - Freeway and Street Segments MCP Area - Alternative 4 Modified

Figure 7-16h

Legend:

XX,XXX Average Daily Traffic



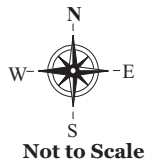
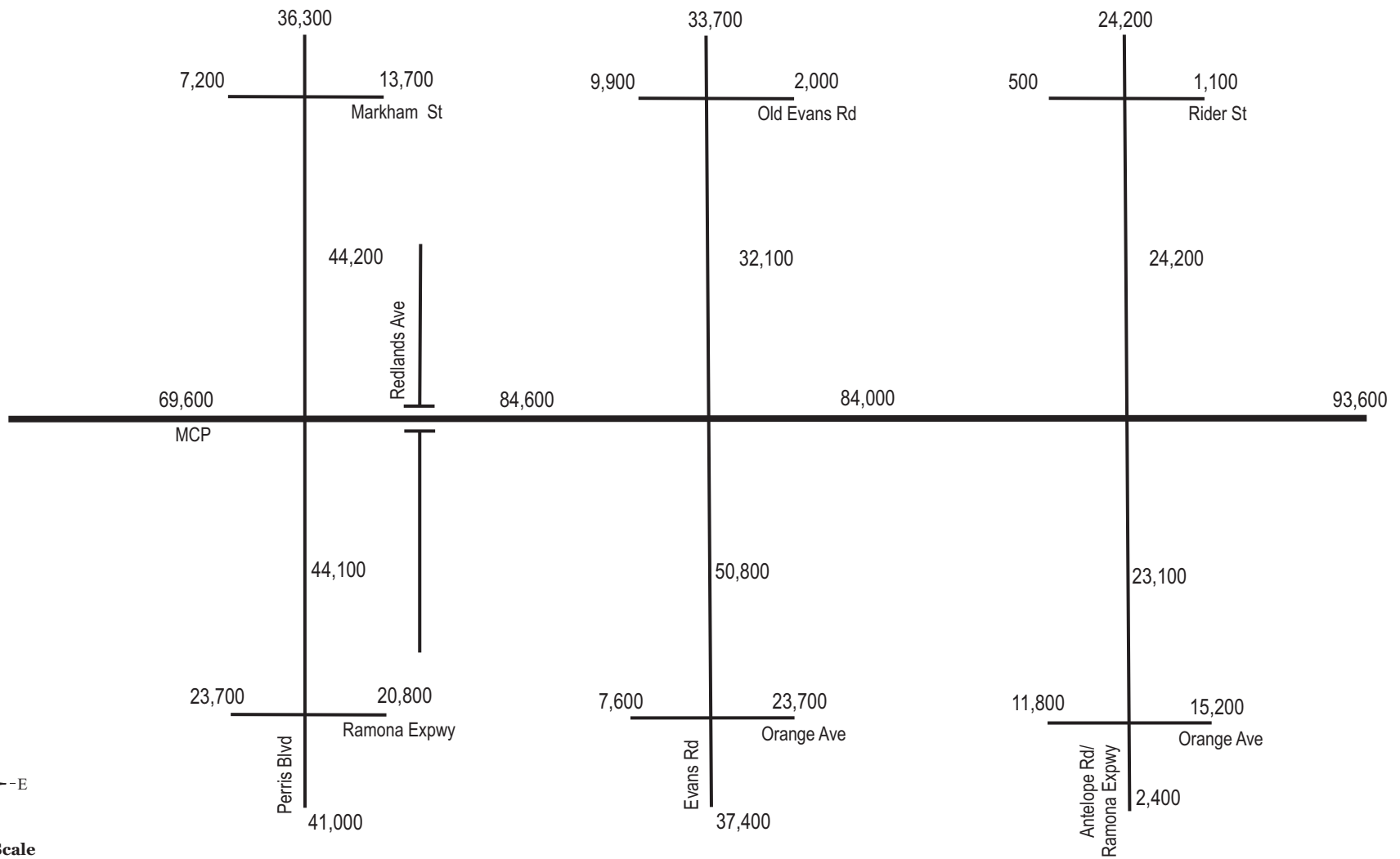

Horizon Year (2040) ADT - Freeway and Street Segments MCP Area - Alternative 4 Modified

Figure 7-16i

Legend:

XX,XXX Average Daily Traffic



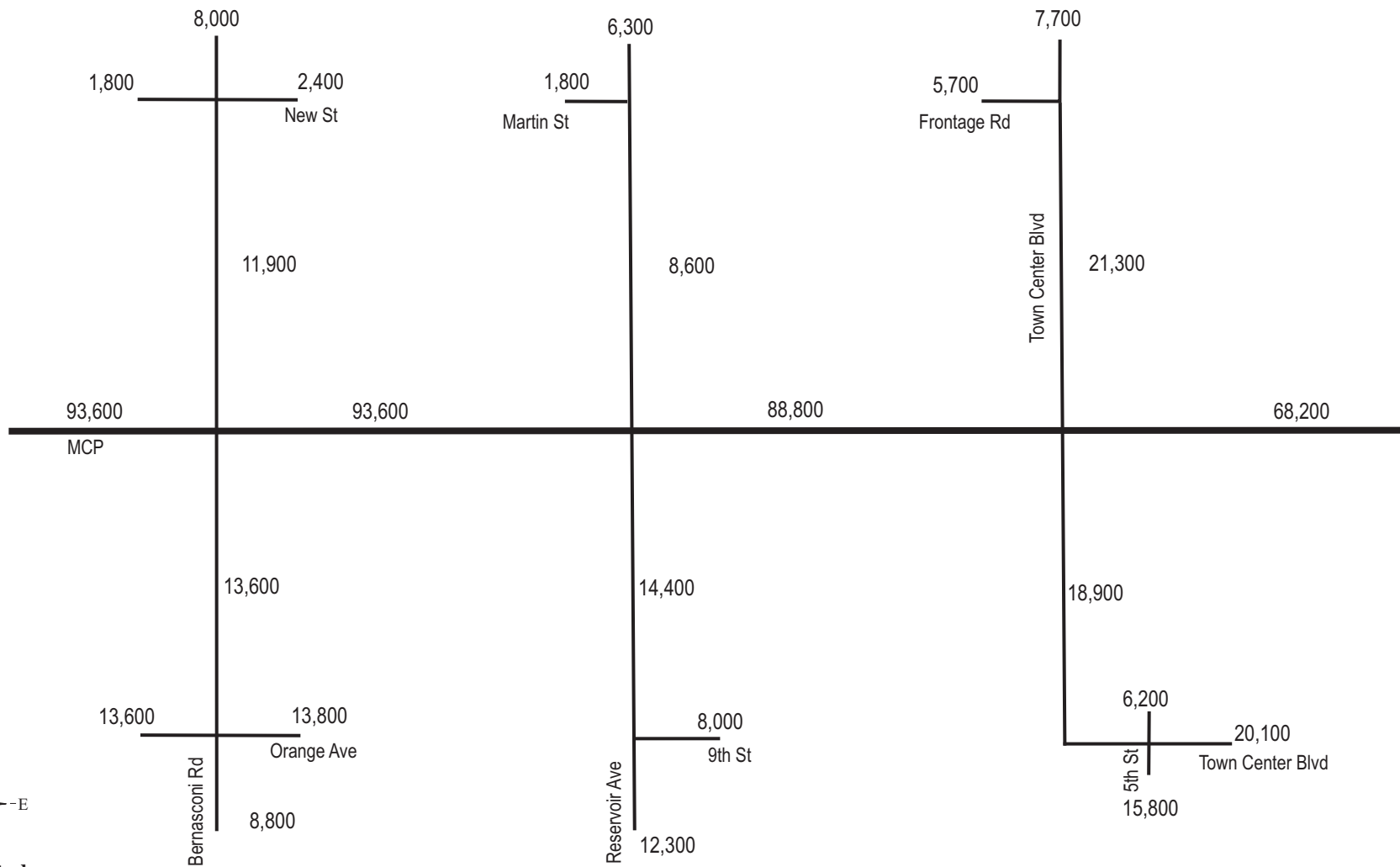

Horizon Year (2040) ADT - Freeway and Street Segments MCP Area - Alternative 4 Modified

Figure 7-16j

Legend:

XX,XXX Average Daily Traffic



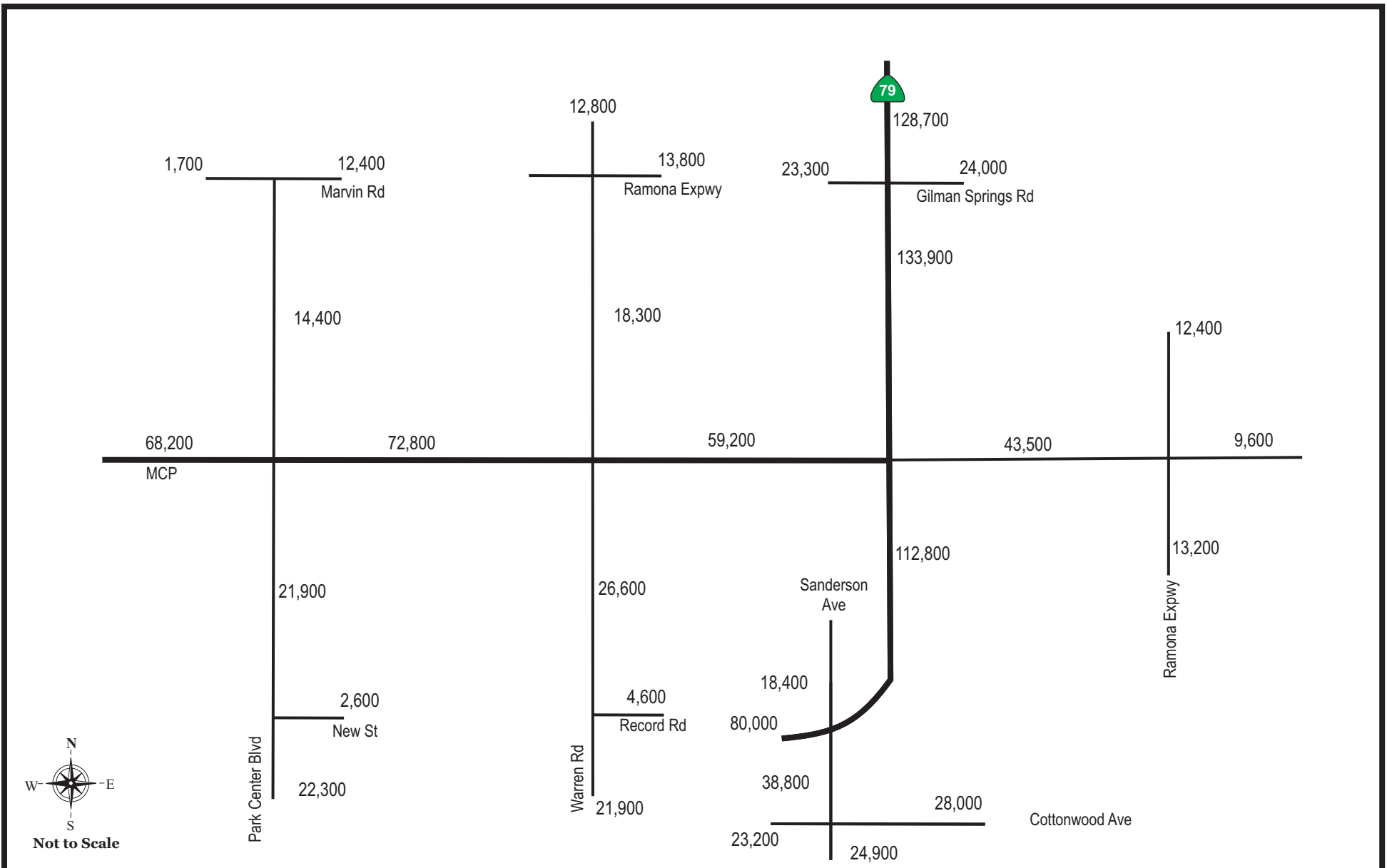

Horizon Year (2040) ADT - Freeway and Street Segments MCP Area - Alternative 4 Modified

Figure 7-16k

Legend:

XX,XXX Average Daily Traffic



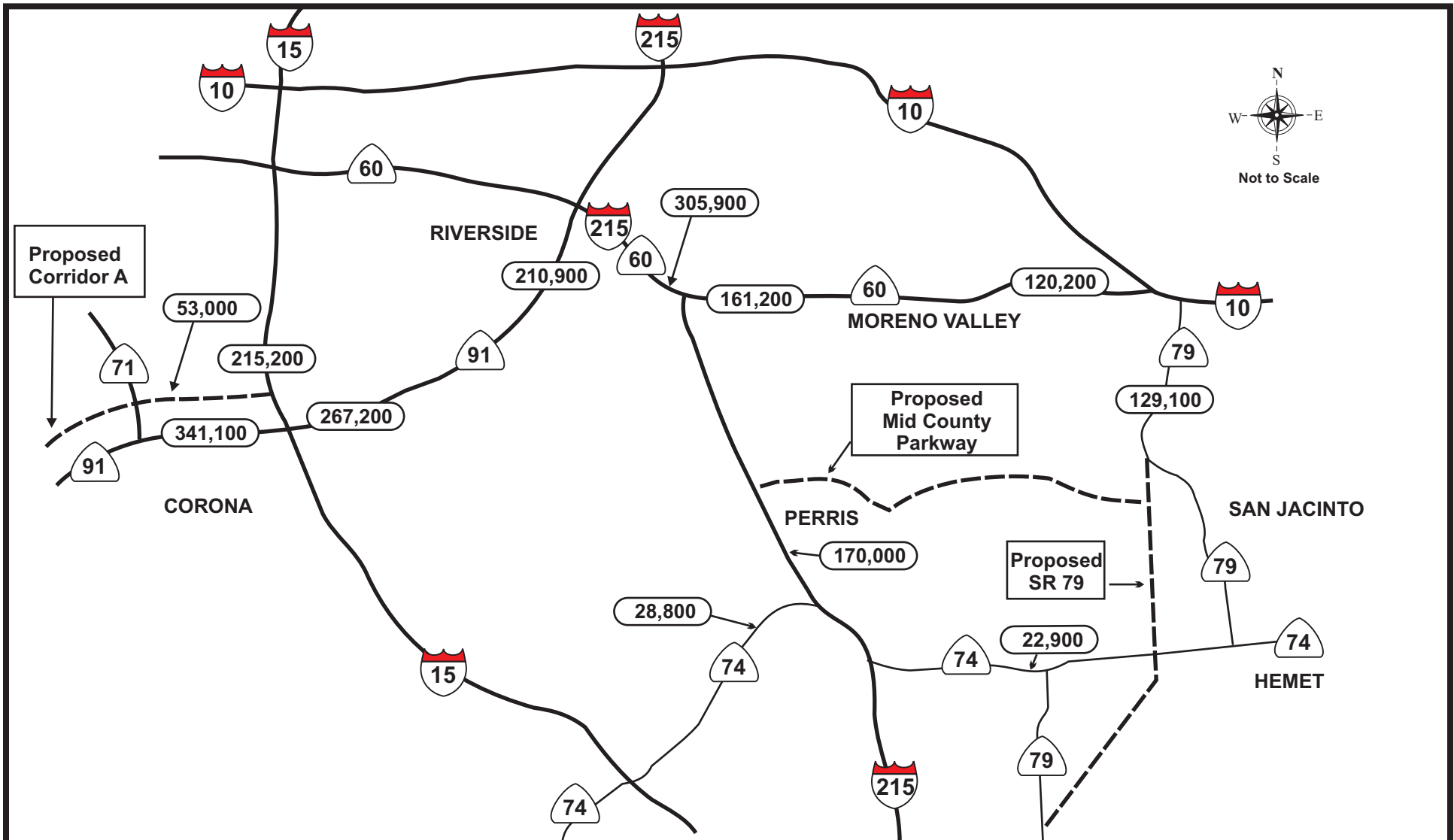

Horizon Year (2040) ADT Freeway and Street Segments Outside MCP Area - Alternative 4 Modified

Figure 7-17



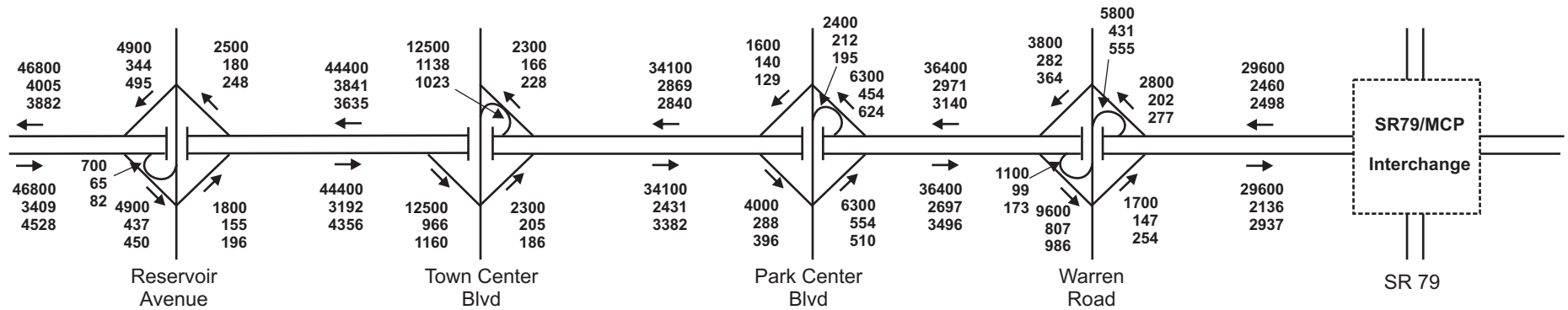
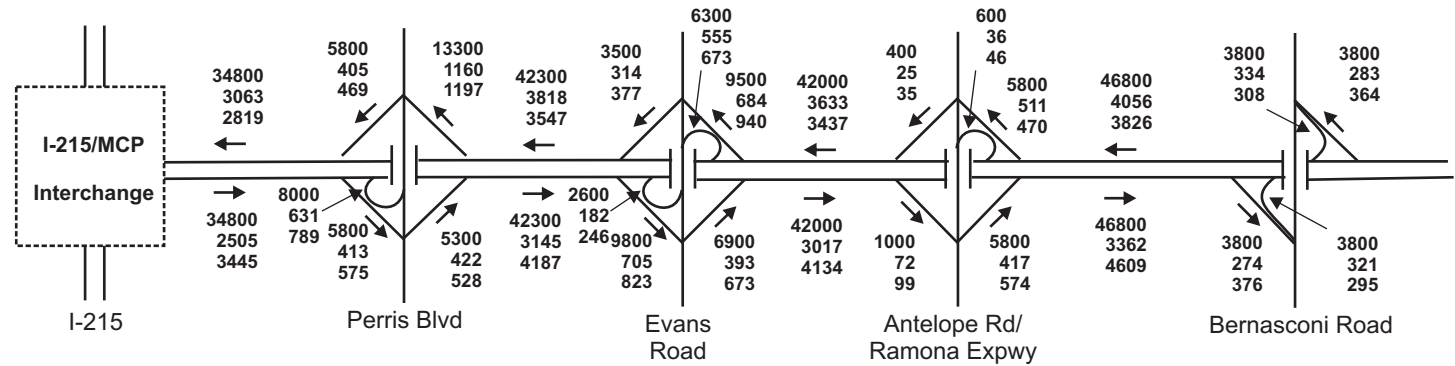

**Horizon Year (2040) Freeway and Ramp Traffic
Mid County Parkway - Alternative 4 Modified**

Figure 7 -18

Legend

XXXXXX Average Daily Traffic

XXXX AM Peak Hour

XXXX PM Peak Hour



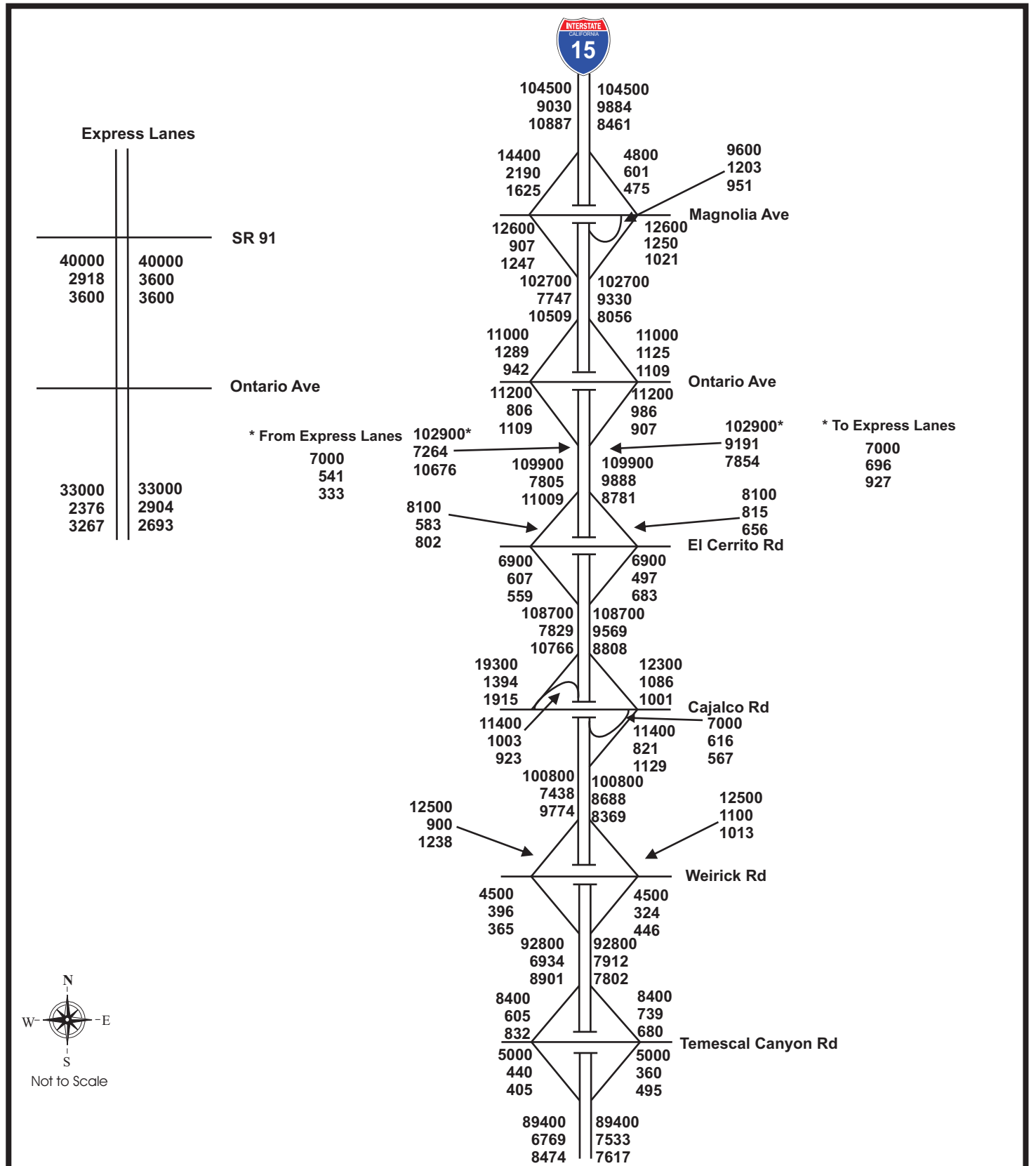

**Horizon Year (2040) Freeway and Ramp Traffic
Interstate 15 - Alternative 4 Modified**

Figure 7-19



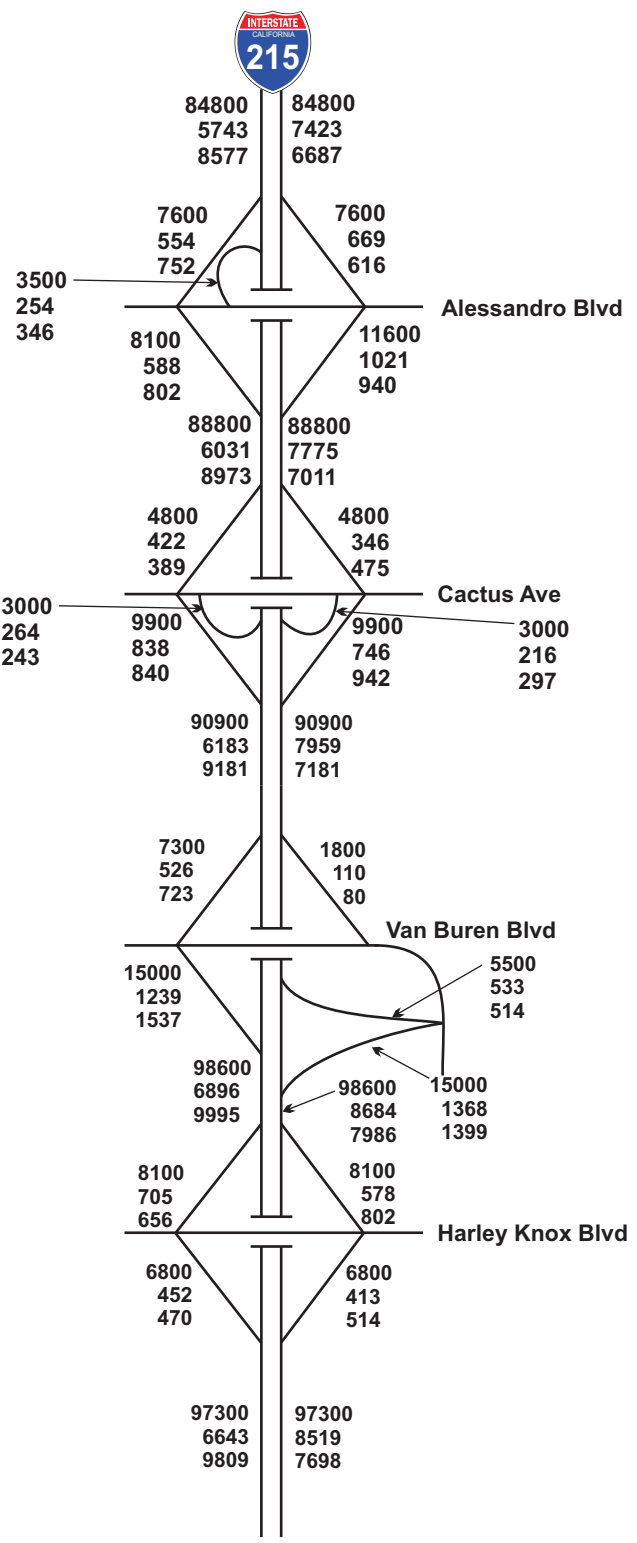
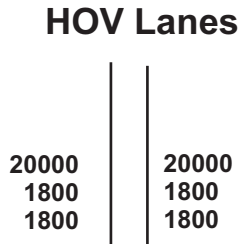

**Horizon Year (2040)
Freeway and Ramp Traffic
Interstate 215 - Alternative 4 Modified**

Figure 7-20a

Legend

- XXXXX Average Daily Traffic
- XXX AM Peak Hour Traffic
- XXX PM Peak Hour Traffic



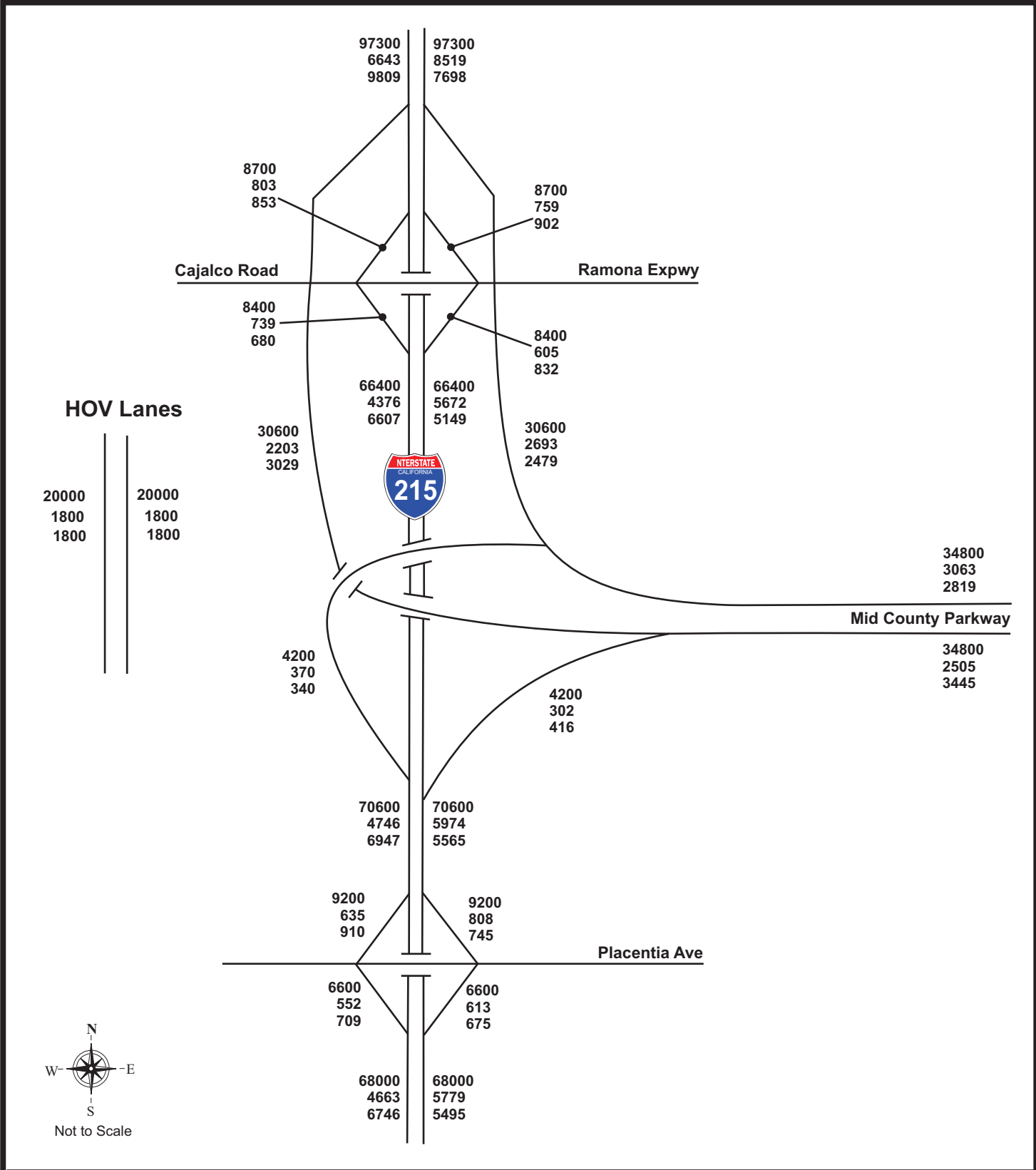

**Horizon Year (2040)
Freeway and Ramp Traffic
Interstate 215 - Alternative 4 Modified**

Figure 7-20b

Legend

- XXXXX Average Daily Traffic
- XXX AM Peak Hour Traffic
- XXX PM Peak Hour Traffic



**HOV Lanes
(North of Nuevo Road Only)**

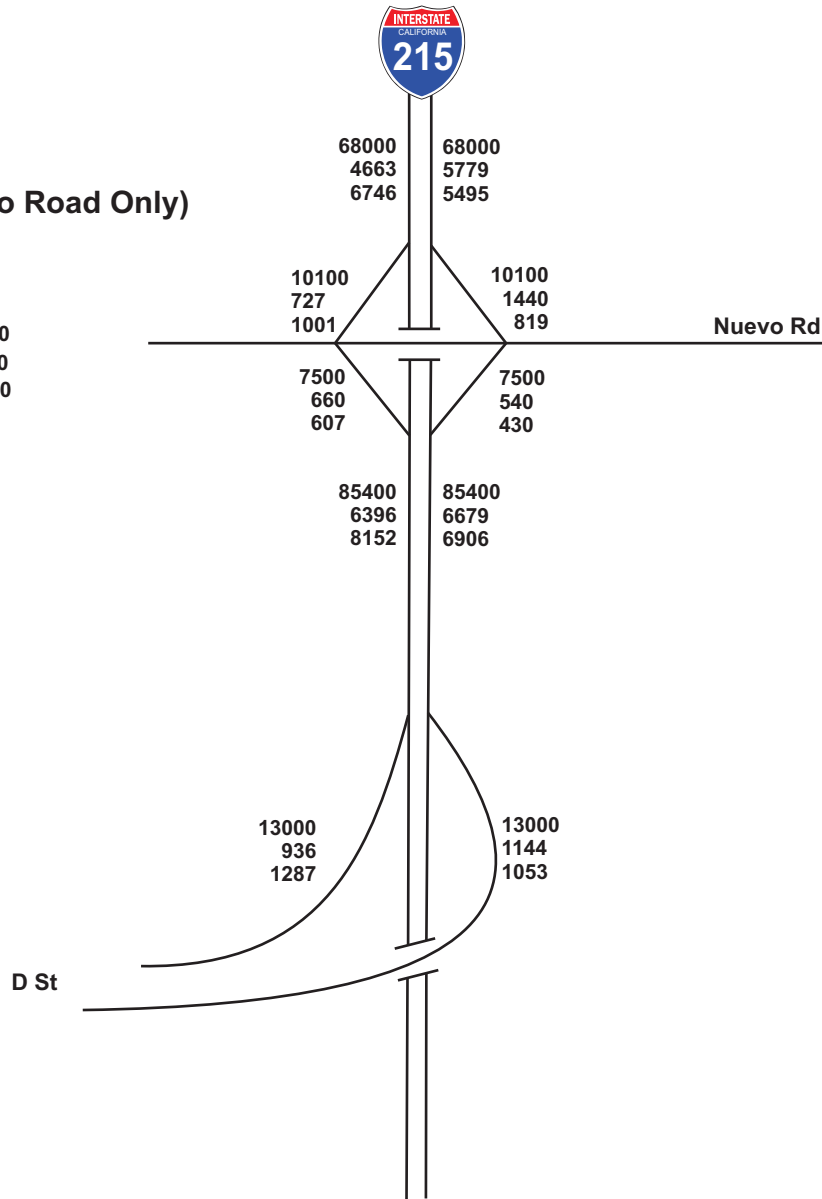
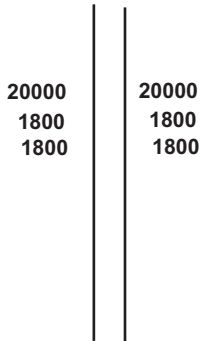

**Horizon Year (2040)
Freeway and Ramp Traffic
Interstate 215 - Alternative 4 Modified**

Figure 7-20c

Legend

- XXXXX Average Daily Traffic
- XXX AM Peak Hour Traffic
- XXX PM Peak Hour Traffic



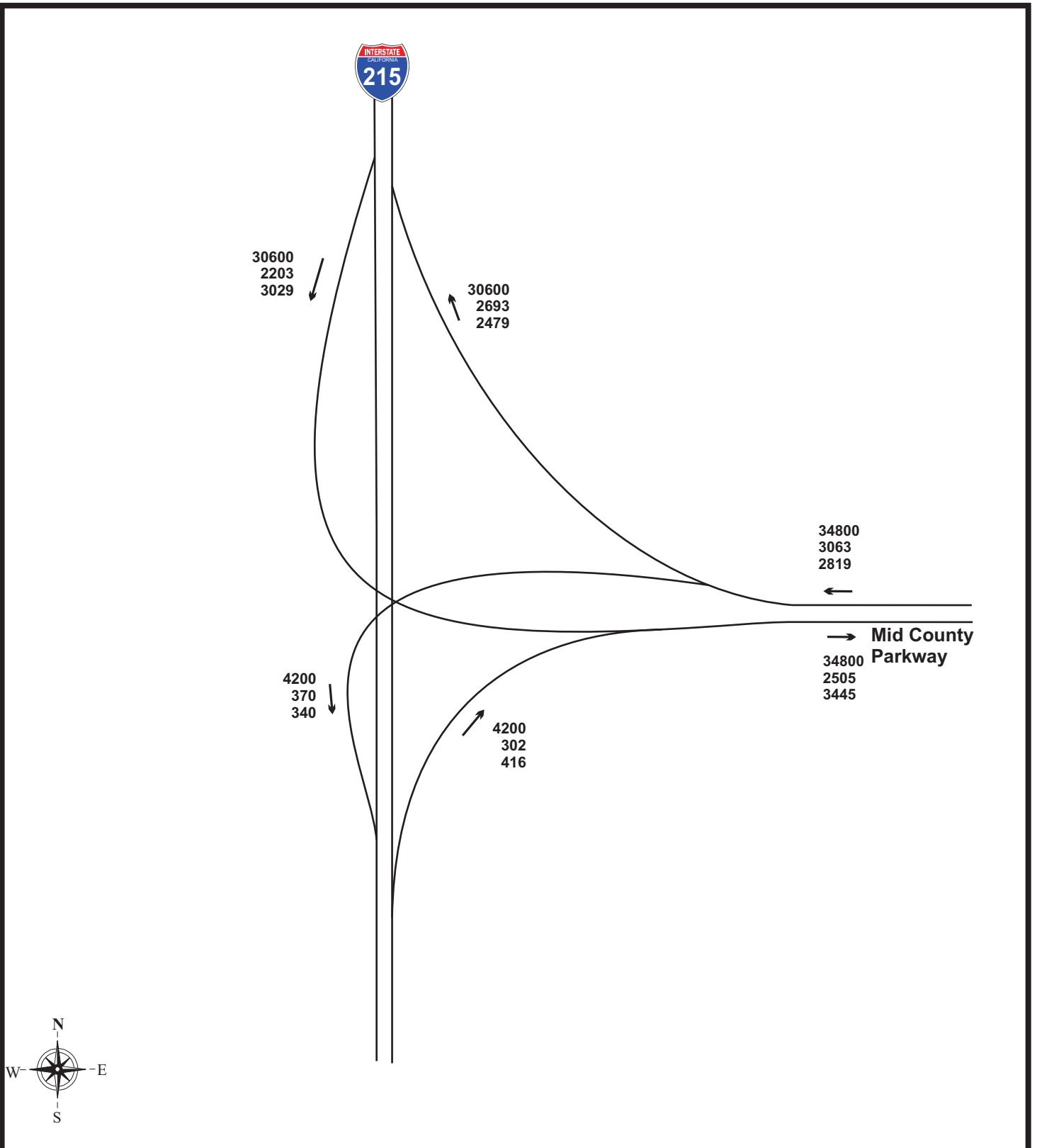

Horizon Year (2040) MCP/I-215 Interchange Area Traffic - Alternative 4 Modified

Figure 7-21

Legend

- XXXXX Average Daily Traffic
- XXXX AM Peak Hour
- XXXX PM Peak Hour



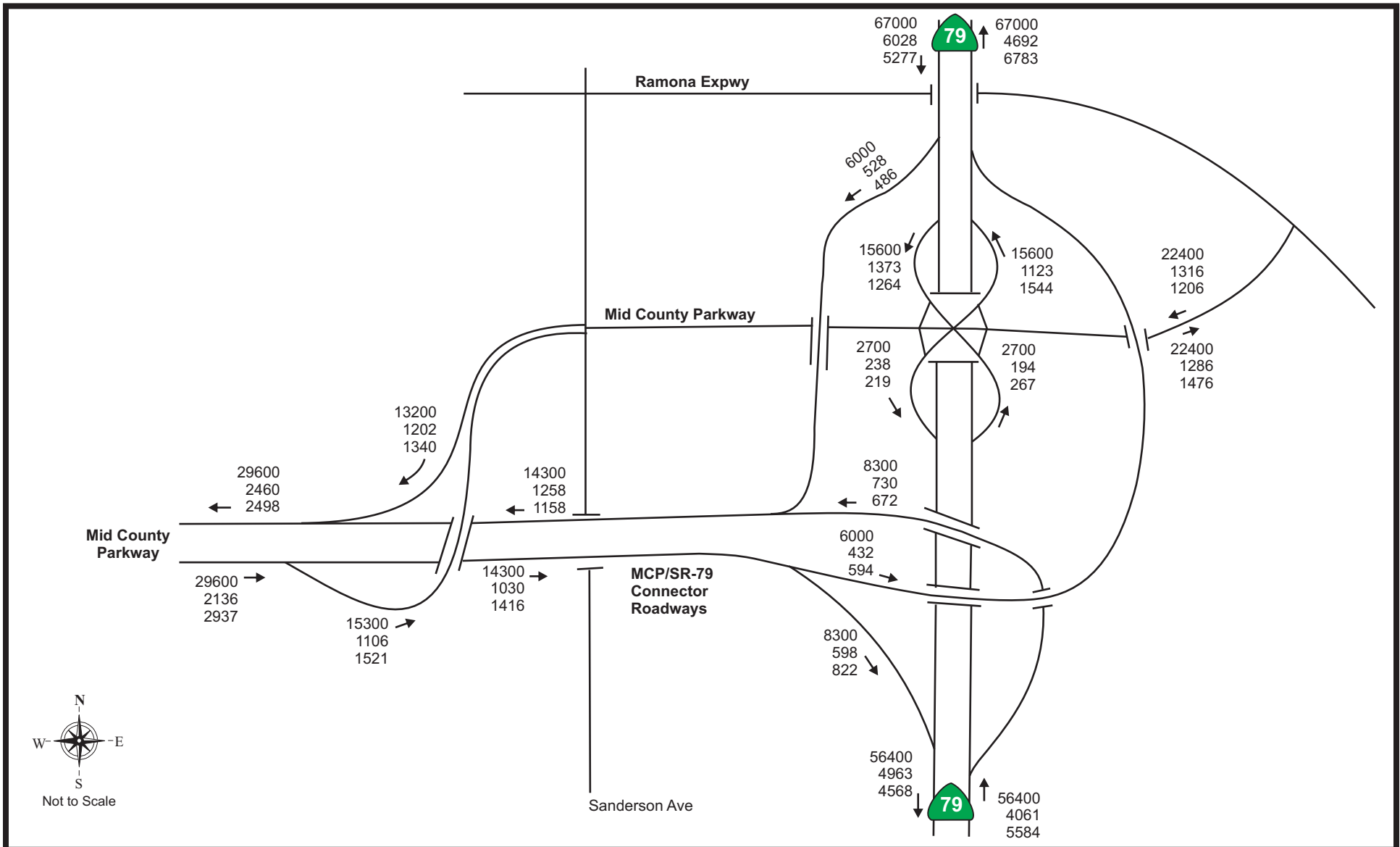

Horizon Year (2040) MCP/SR-79 Interchange Area Traffic - Alternative 4 Modified

Figure 7-22



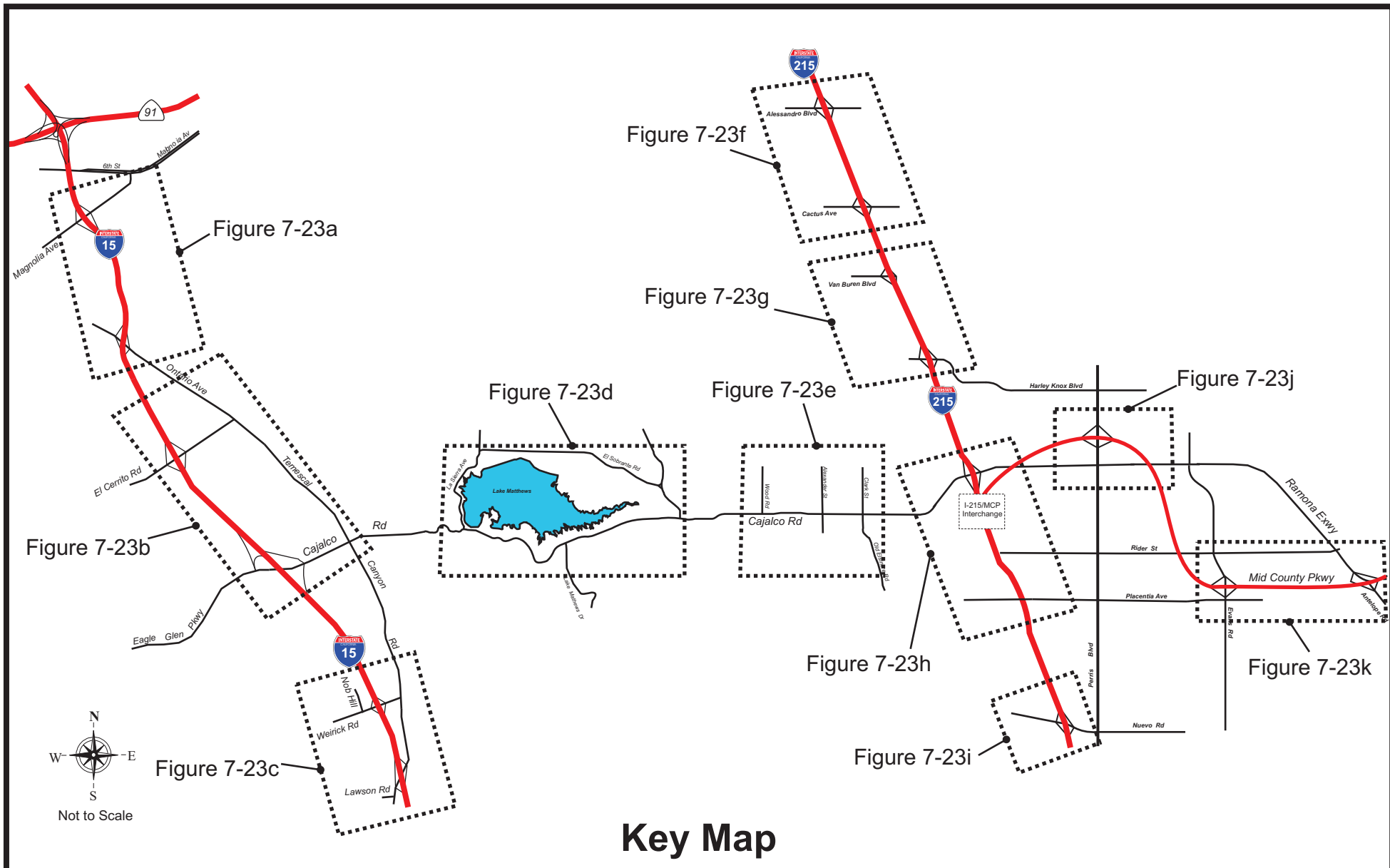

Key Map

Horizon Year (2040) AM/PM Peak Hour Traffic - Intersections Alternative 4 Modified

Figure 7-23

Legend:

 Figure Areas



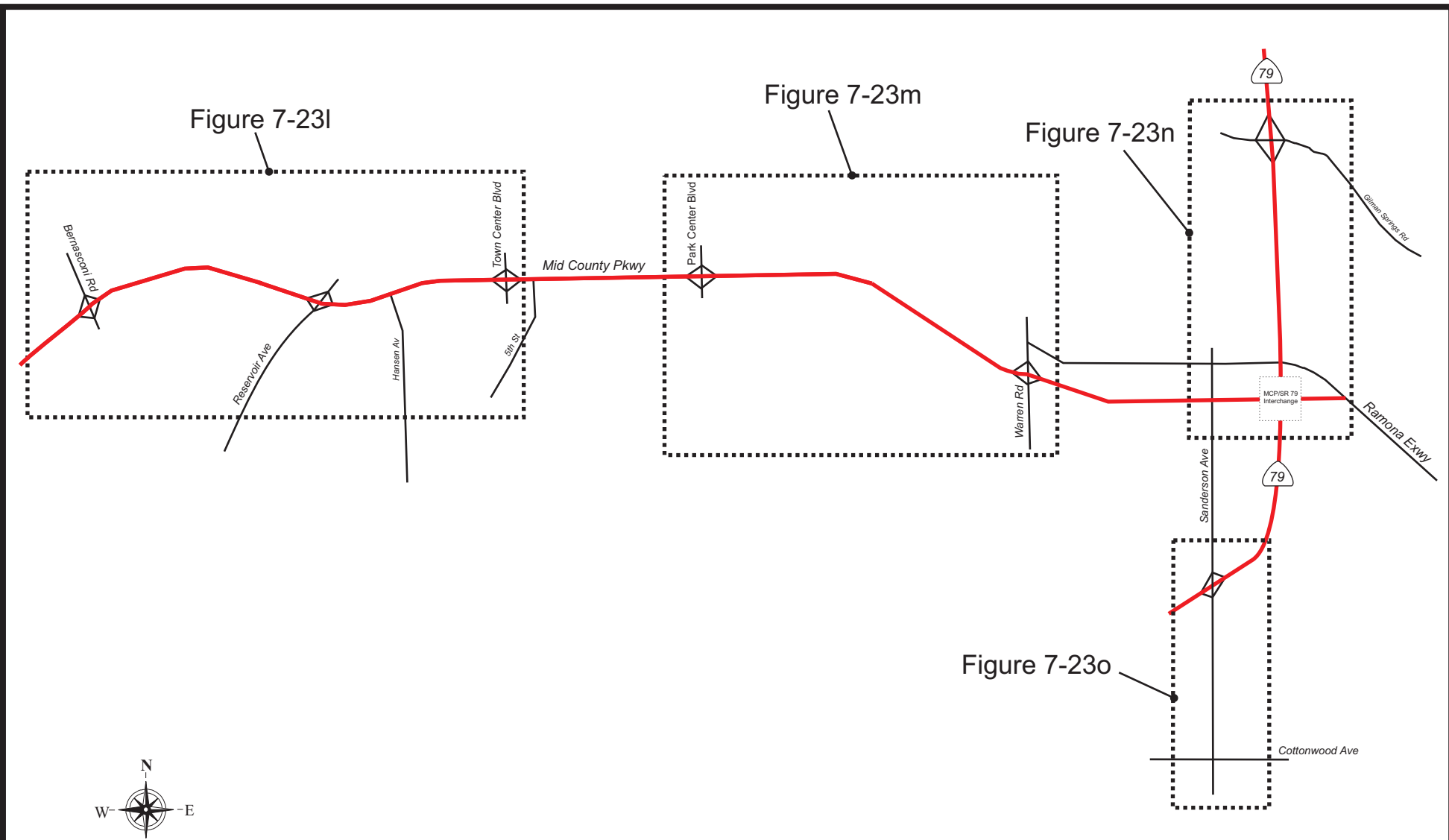

Key Map

**Horizon Year (2040) AM/PM Peak Hour Traffic - Intersections
Alternative 4 Modified**

Figure 7-23 (cont.)

Legend:

 Figure Areas



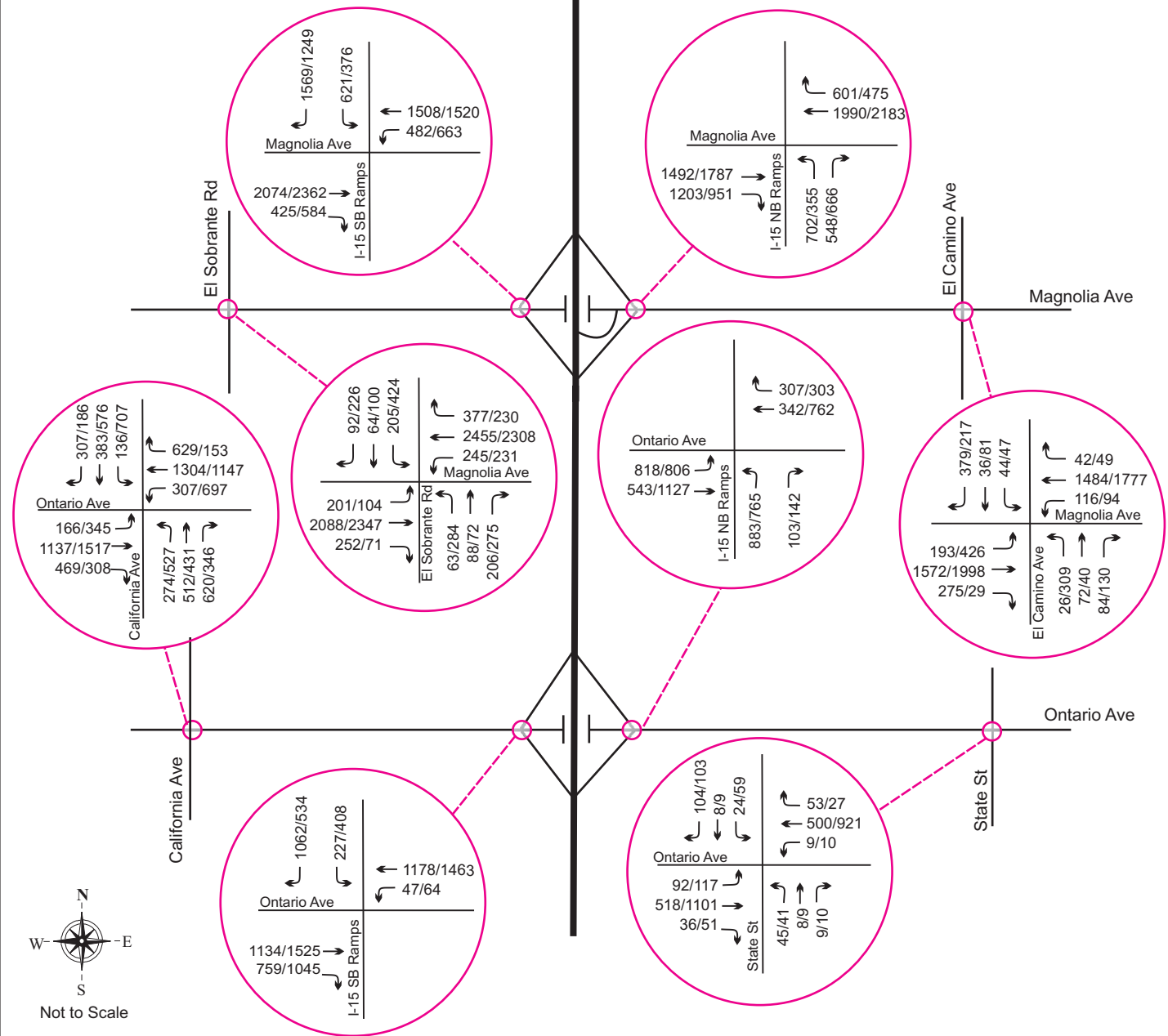

Horizon Year (2040) AM/PM Peak Hour Traffic Intersections - Alternative 4 Modified

Figure 7-23a

XXX/XXX AM/PM Peak Hour



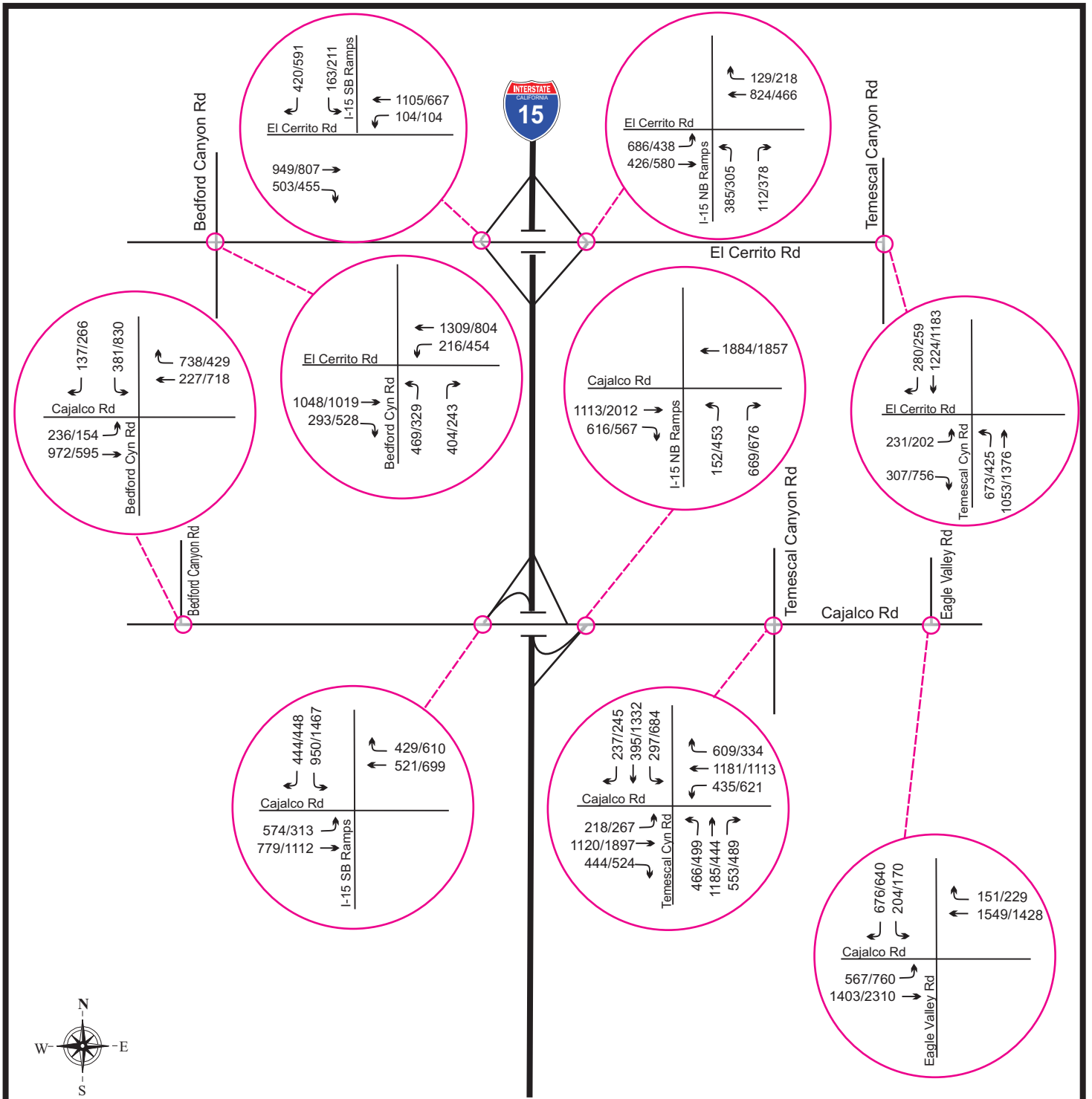

Horizon Year (2040) AM/PM Peak Hour Traffic Intersections - Alternative 4 Modified

Figure 7-23b

XXX/XXX AM/PM Peak Hour



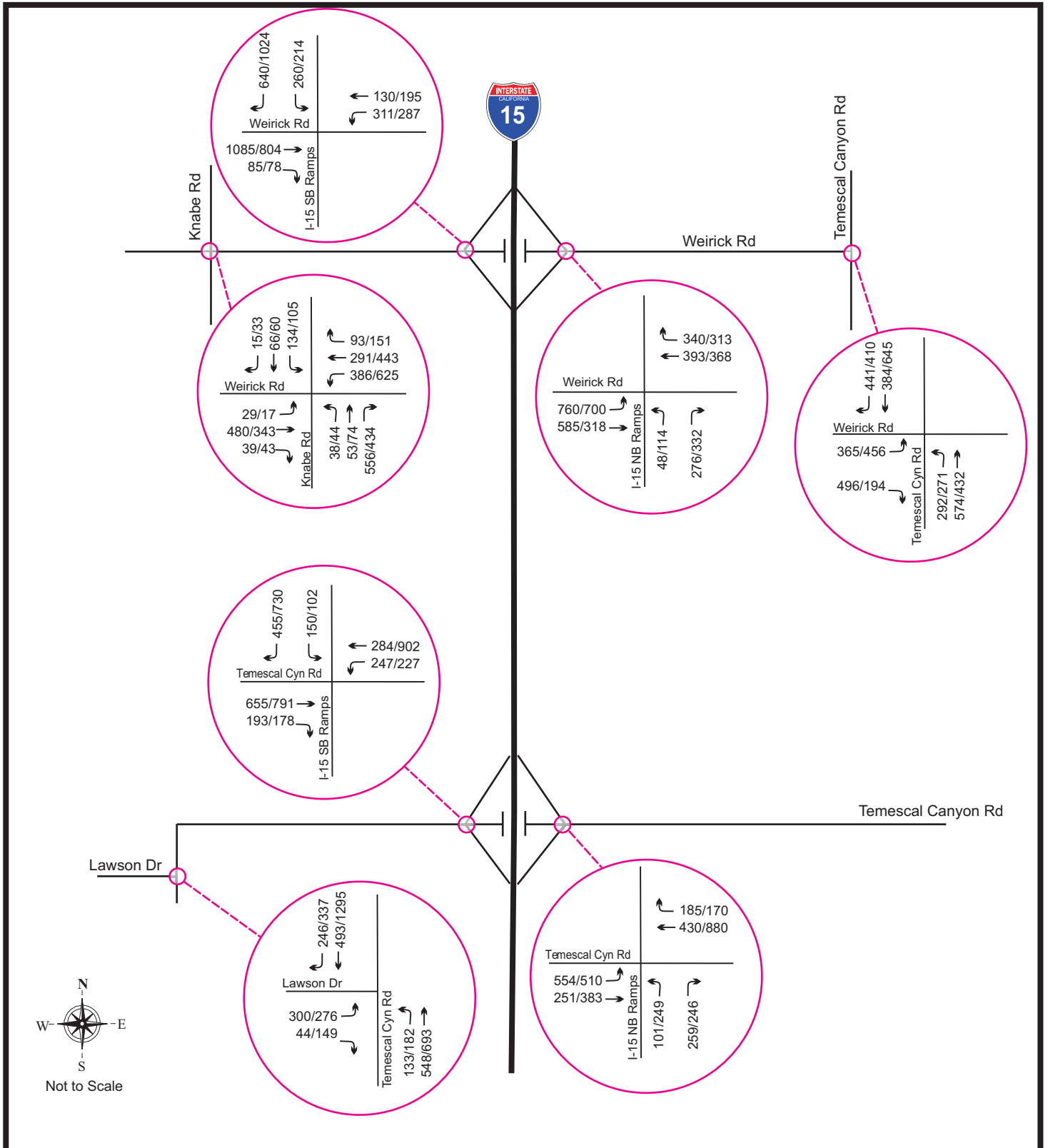

Horizon Year (2040) AM/PM Peak Hour Traffic Intersections - Alternative 4 Modified

Figure 7-23c

XXX/XXX AM/PM Peak Hour



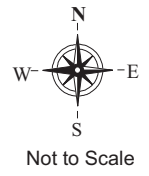
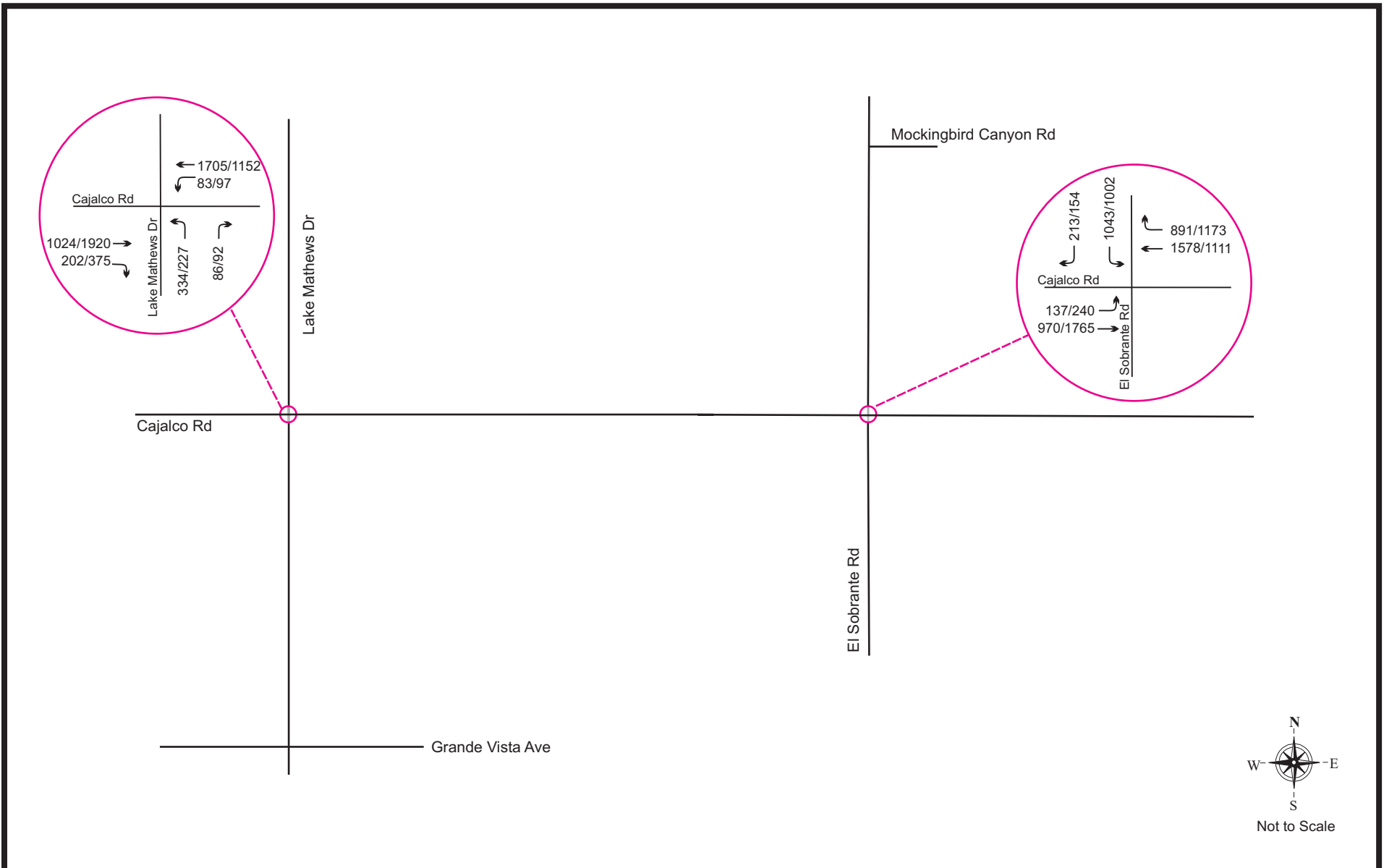

**Horizon Year (2040) AM/PM Peak Hour Traffic Intersections
Alternative 4 Modified**

Figure 7-23d

XXX/XXX AM/PM Peak Hour



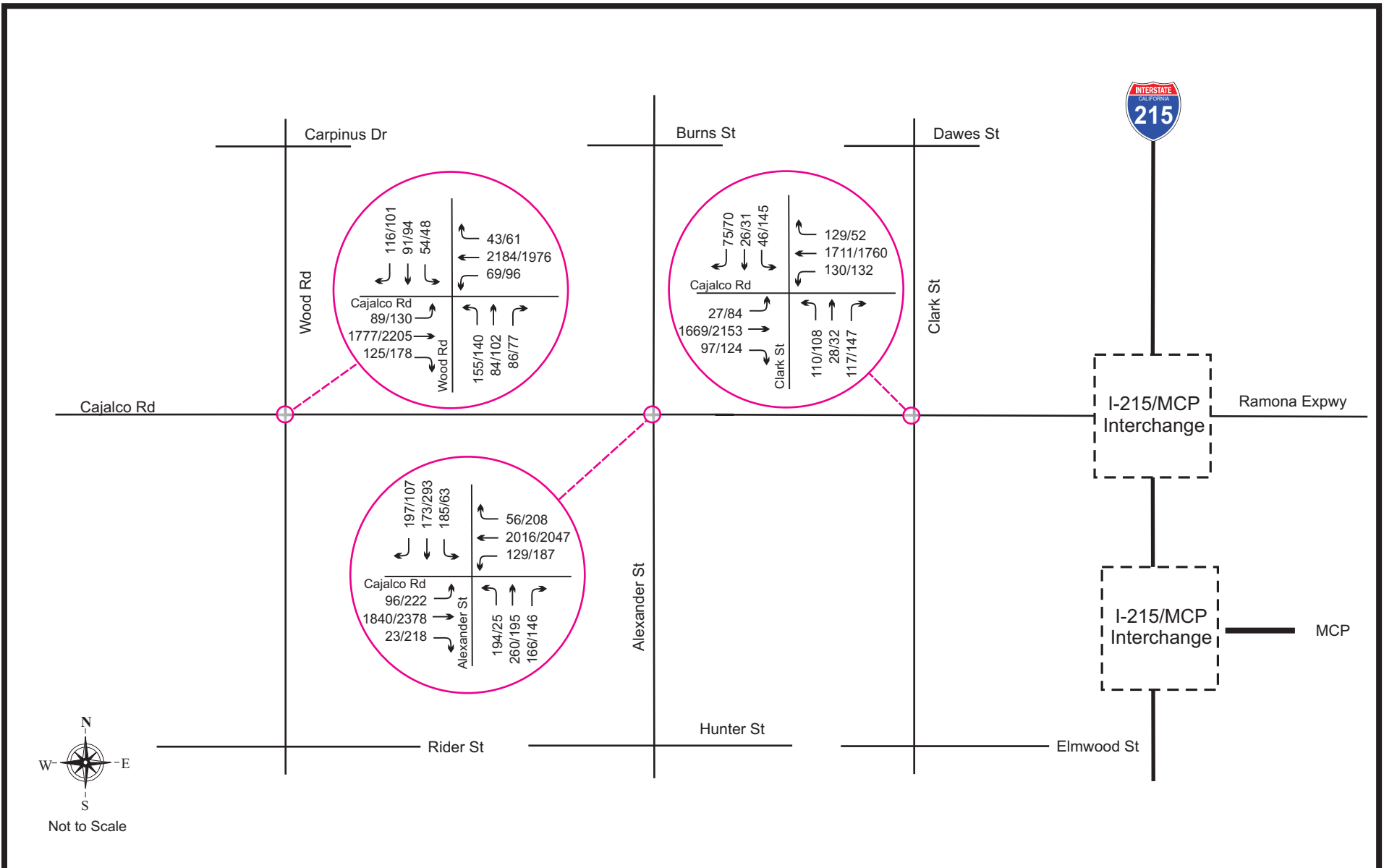

**Horizon Year (2040) AM/PM Peak Hour Traffic Intersections
Alternative 4 Modified**

Figure 7-23e

XXX/XXX AM/PM Peak Hour



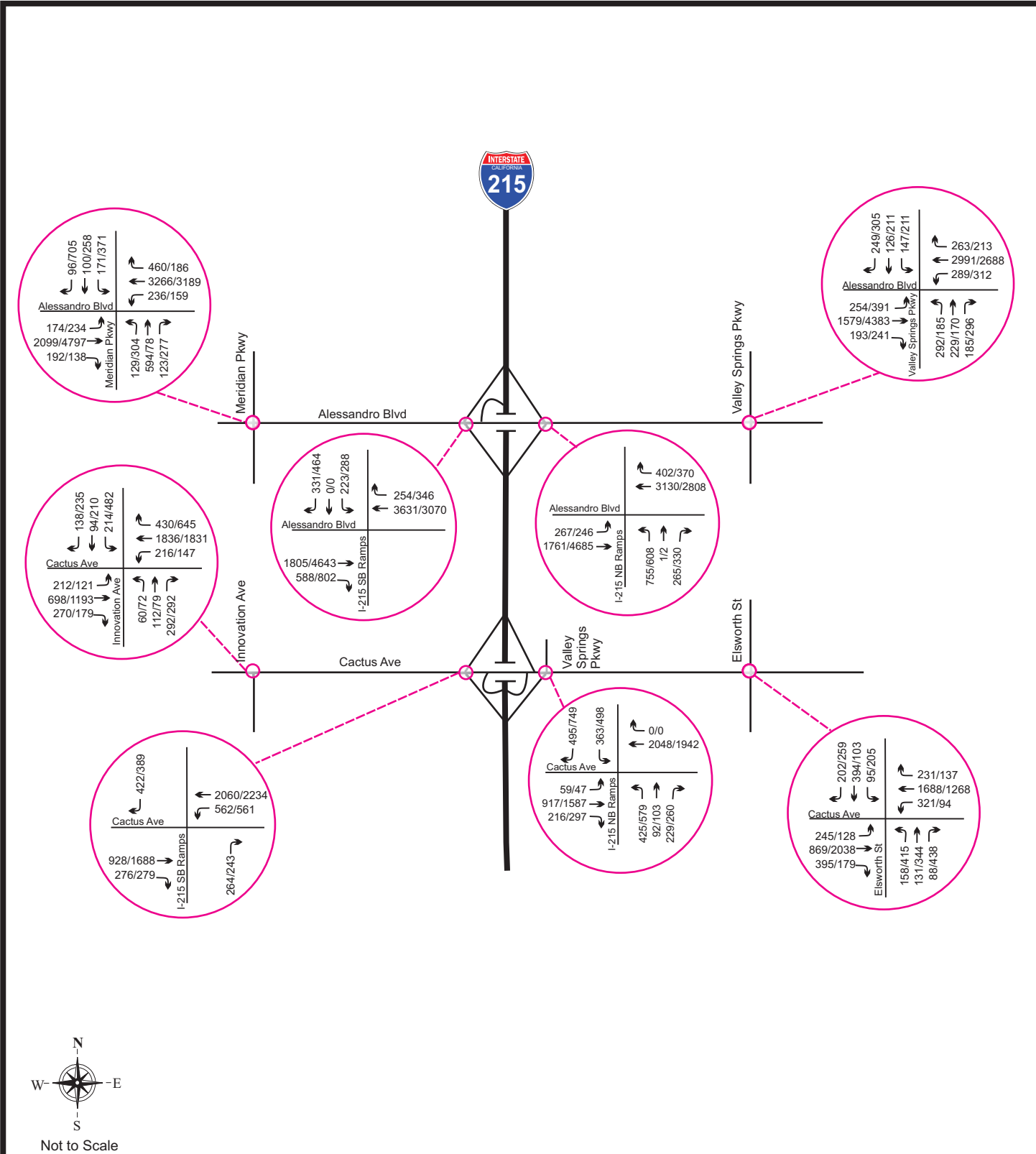

Horizon Year (2040) AM/PM Peak Hour Traffic Intersections - Alternative 4 Modified

Figure 7-23f

XXX/XXX AM/PM Peak Hour



VRPA TECHNOLOGIES, INC.

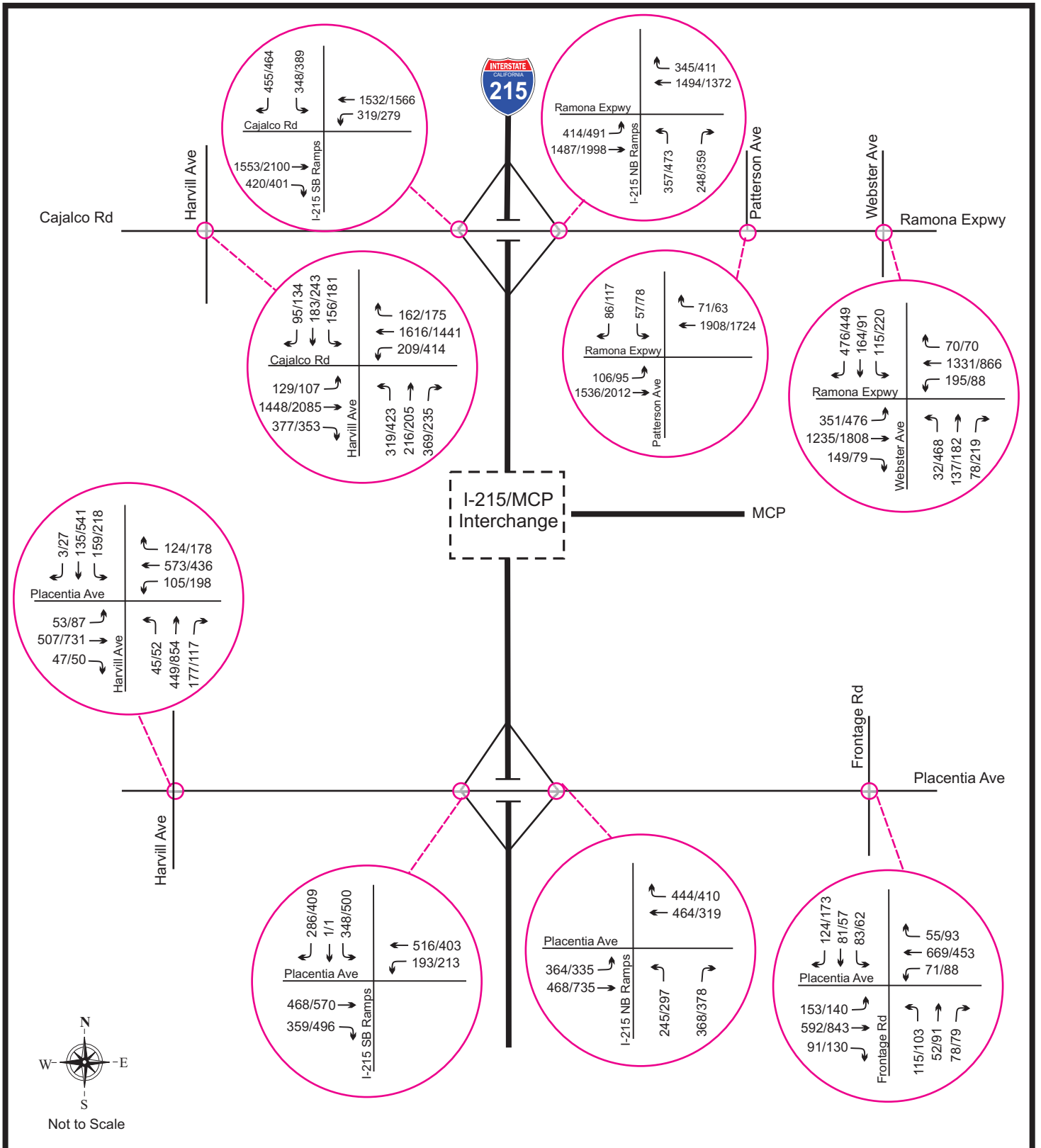

Horizon Year (2040) AM/PM Peak Hour Traffic Intersections - Alternative 4 Modified

Figure 7-23h

XXX/XXX AM/PM Peak Hour



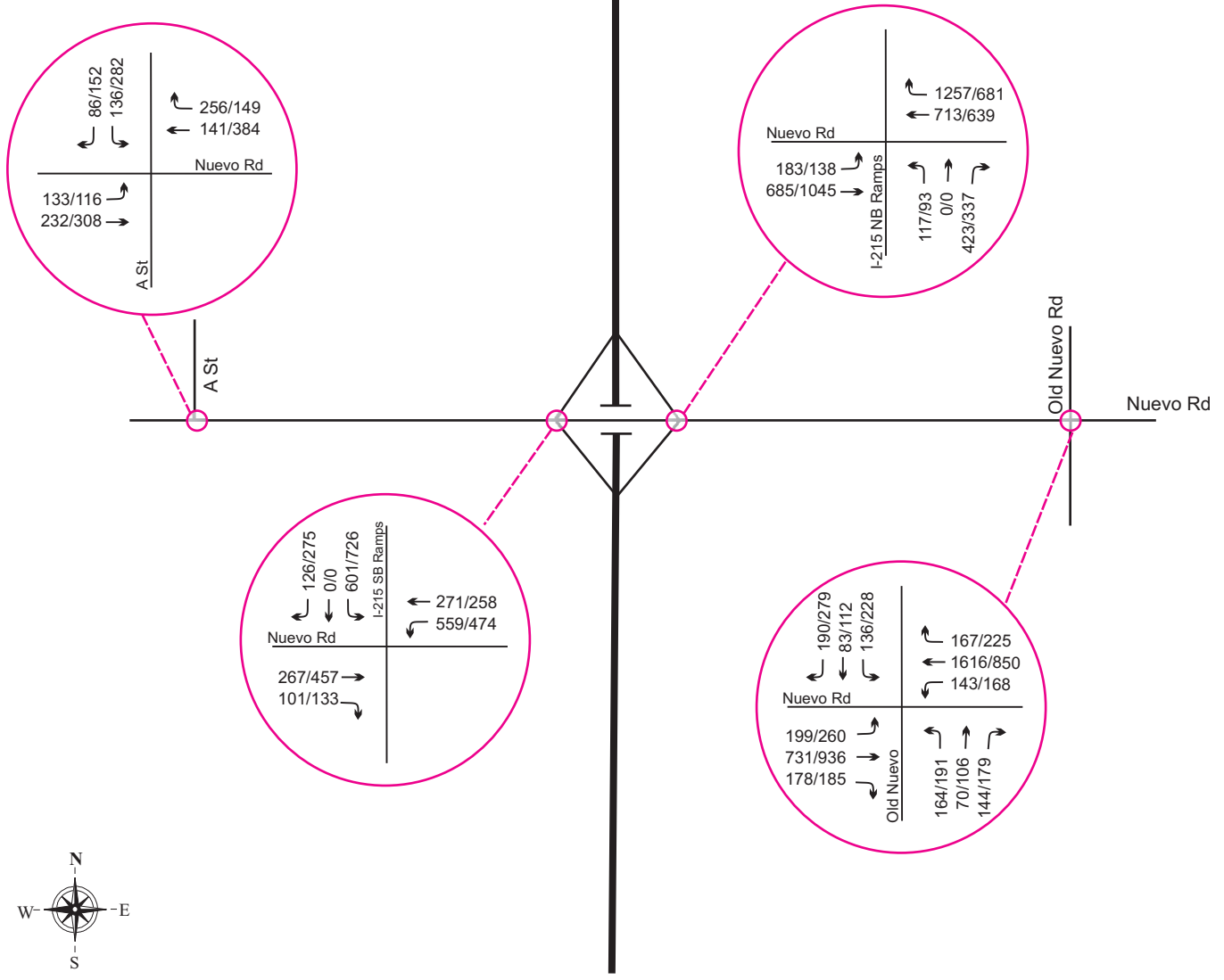

Not to Scale

Horizon Year (2040) AM/PM Peak Hour Traffic Intersections - Alternative 4 Modified

Figure 7-23i

XXX/XXX AM/PM Peak Hour



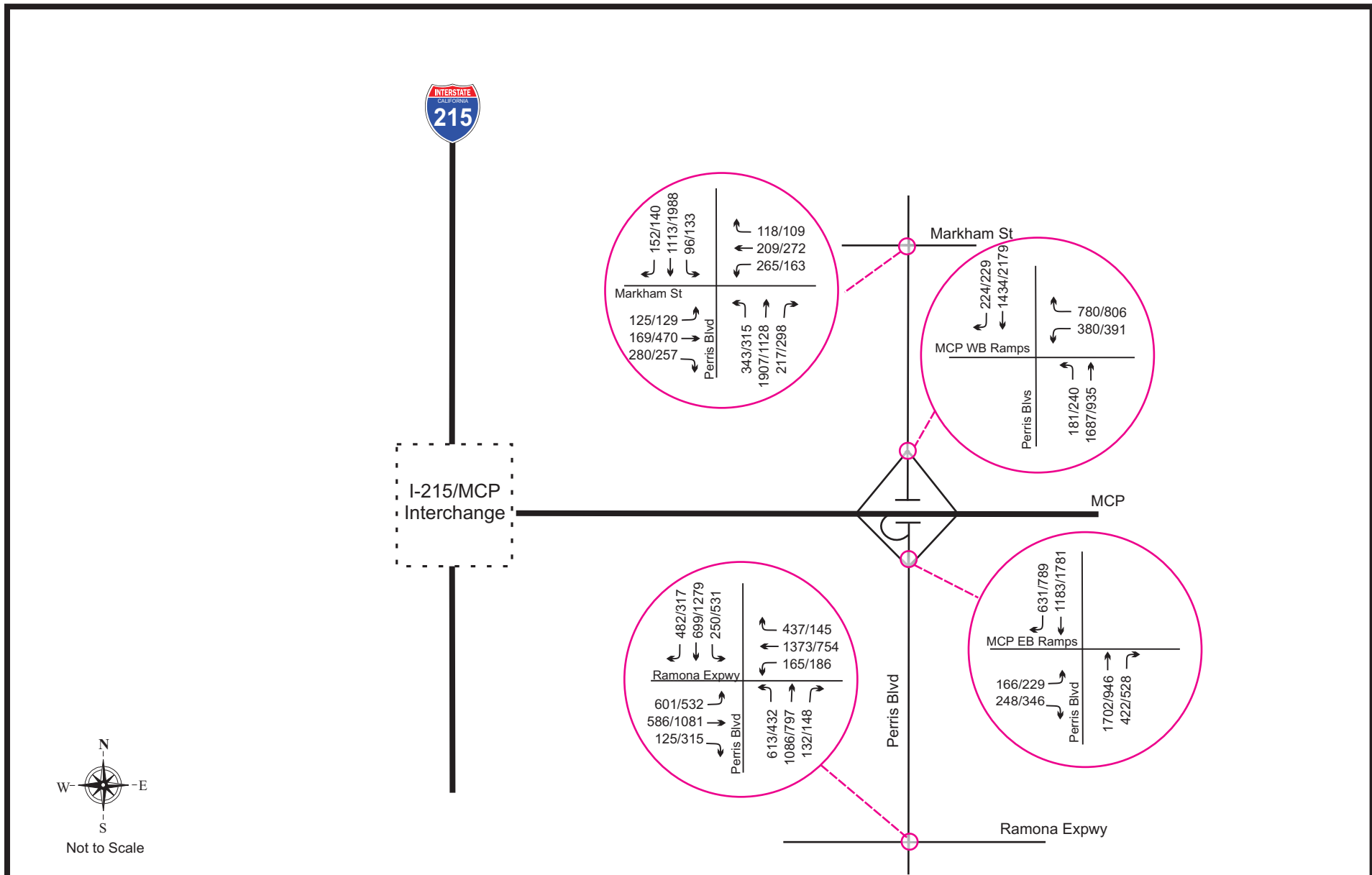

**Horizon Year (2040) AM/PM Peak Hour Traffic Intersections
Alternative 4 Modified**

Figure 7-23j

XXX/XXX AM/PM Peak Hour



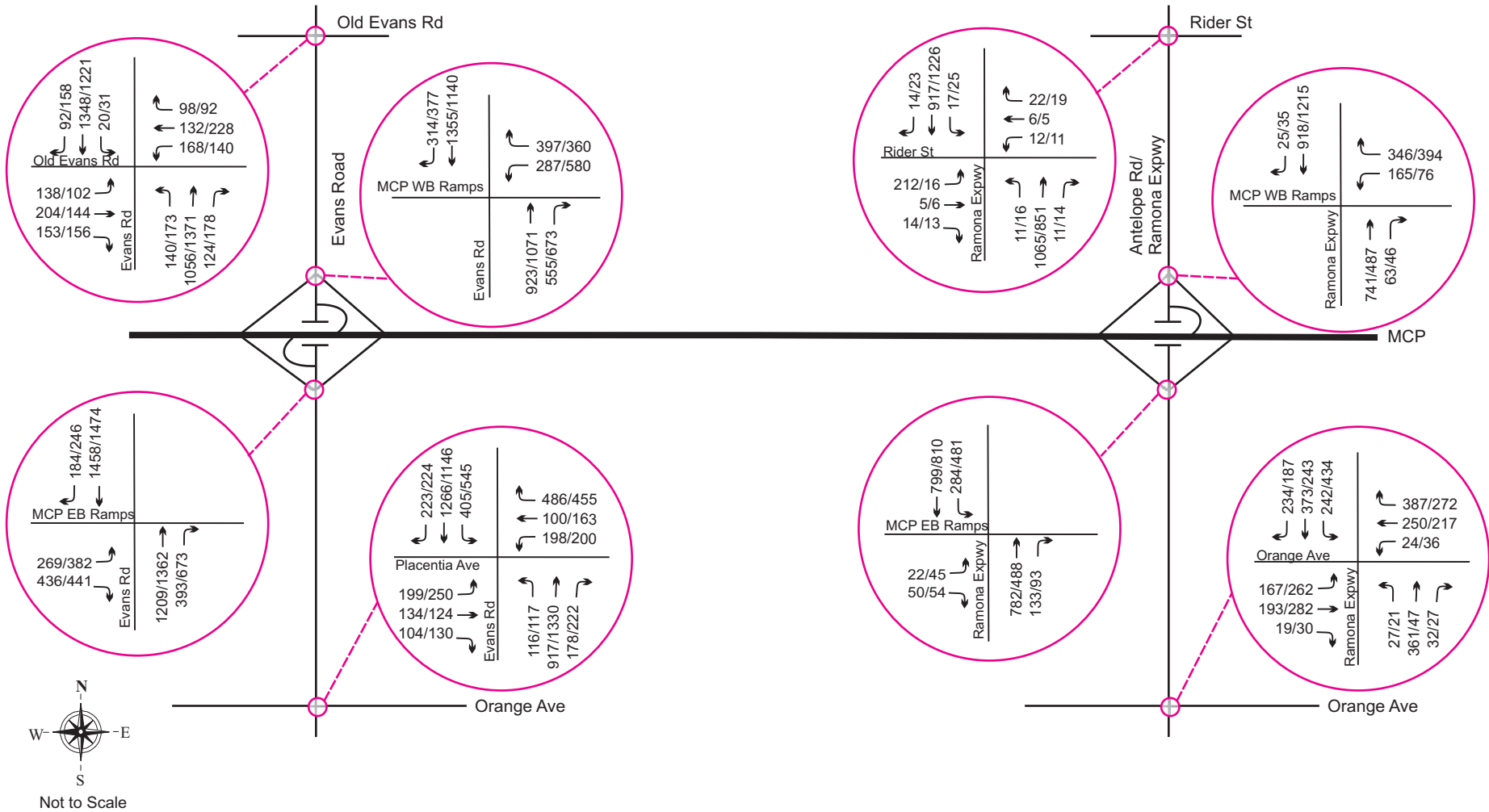

**Horizon Year (2040) AM/PM Peak Hour Traffic Intersections
Alternative 4 Modified**

Figure 7-23k

XXX/XXX AM/PM Peak Hour



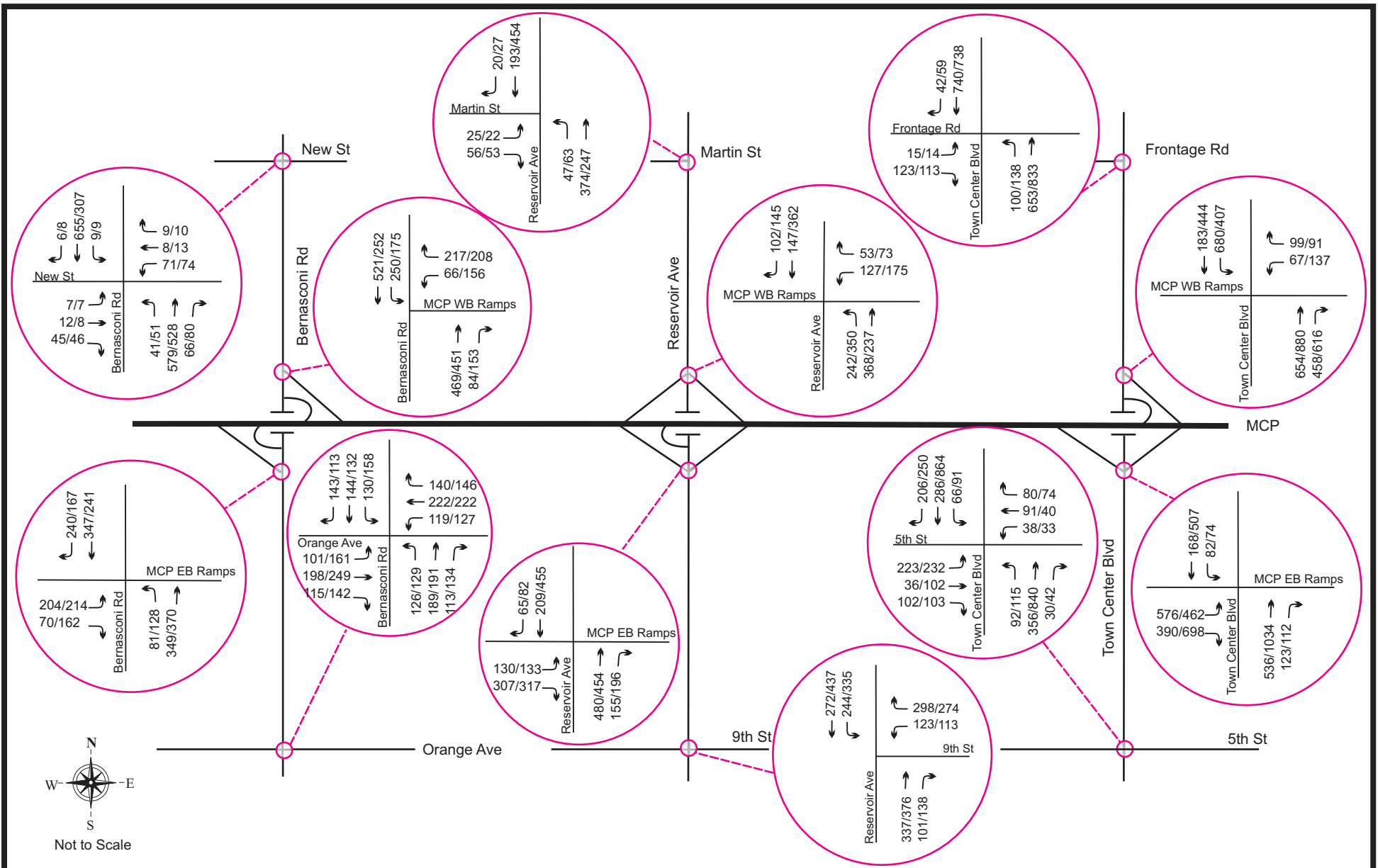

**Horizon Year (2040) AM/PM Peak Hour Traffic Intersections
Alternative 4 Modified**

Figure 7-23I

XXX/XXX AM/PM Peak Hour



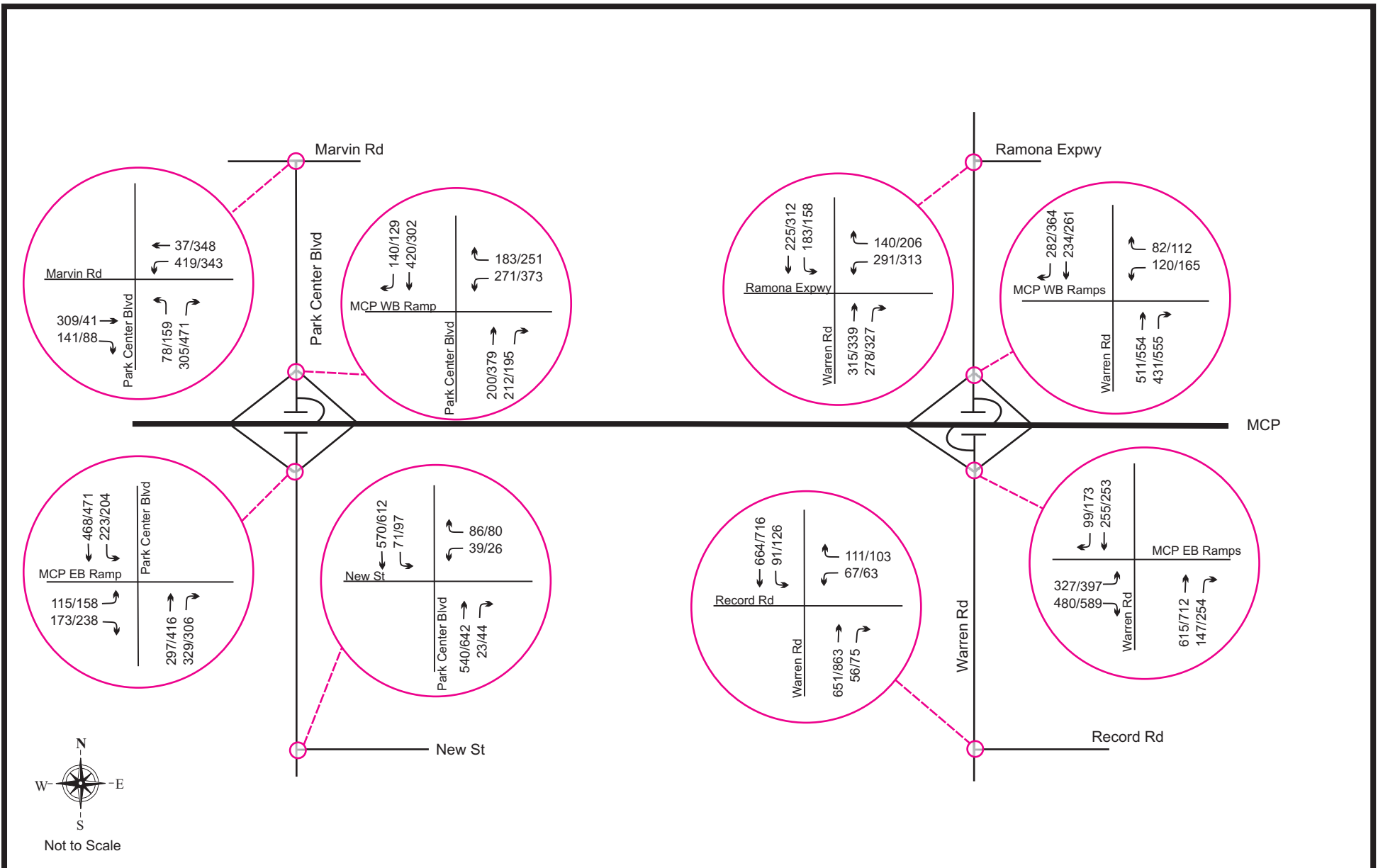

**Horizon Year (2040) AM/PM Peak Hour Traffic Intersections
Alternative 4 Modified**

Figure 7-23m

XXX/XXX AM/PM Peak Hour



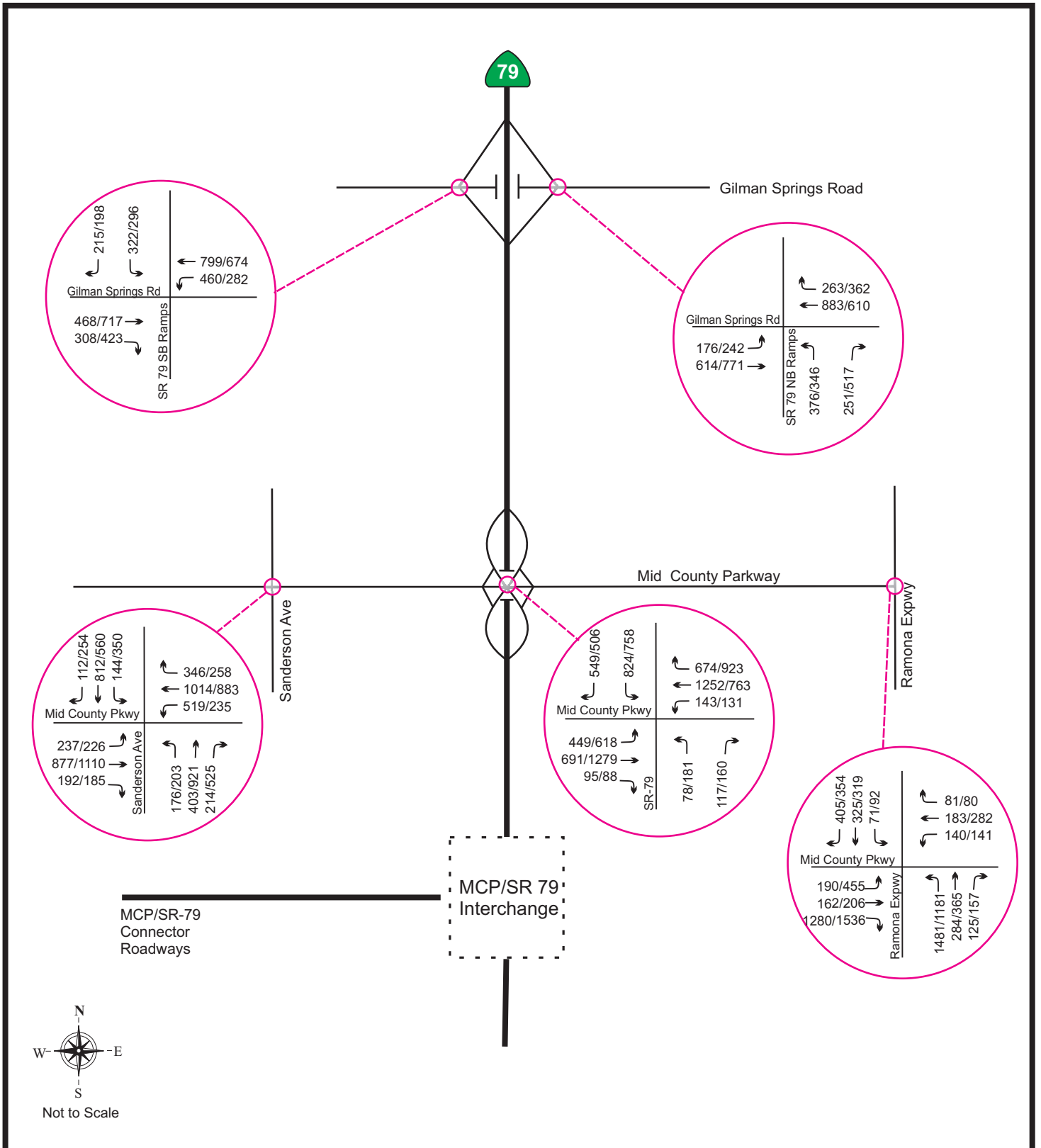

Horizon Year (2040) AM/PM Peak Hour Traffic Intersections - Alternative 4 Modified

Figure 7-23n

XXX/XXX AM/PM Peak Hour



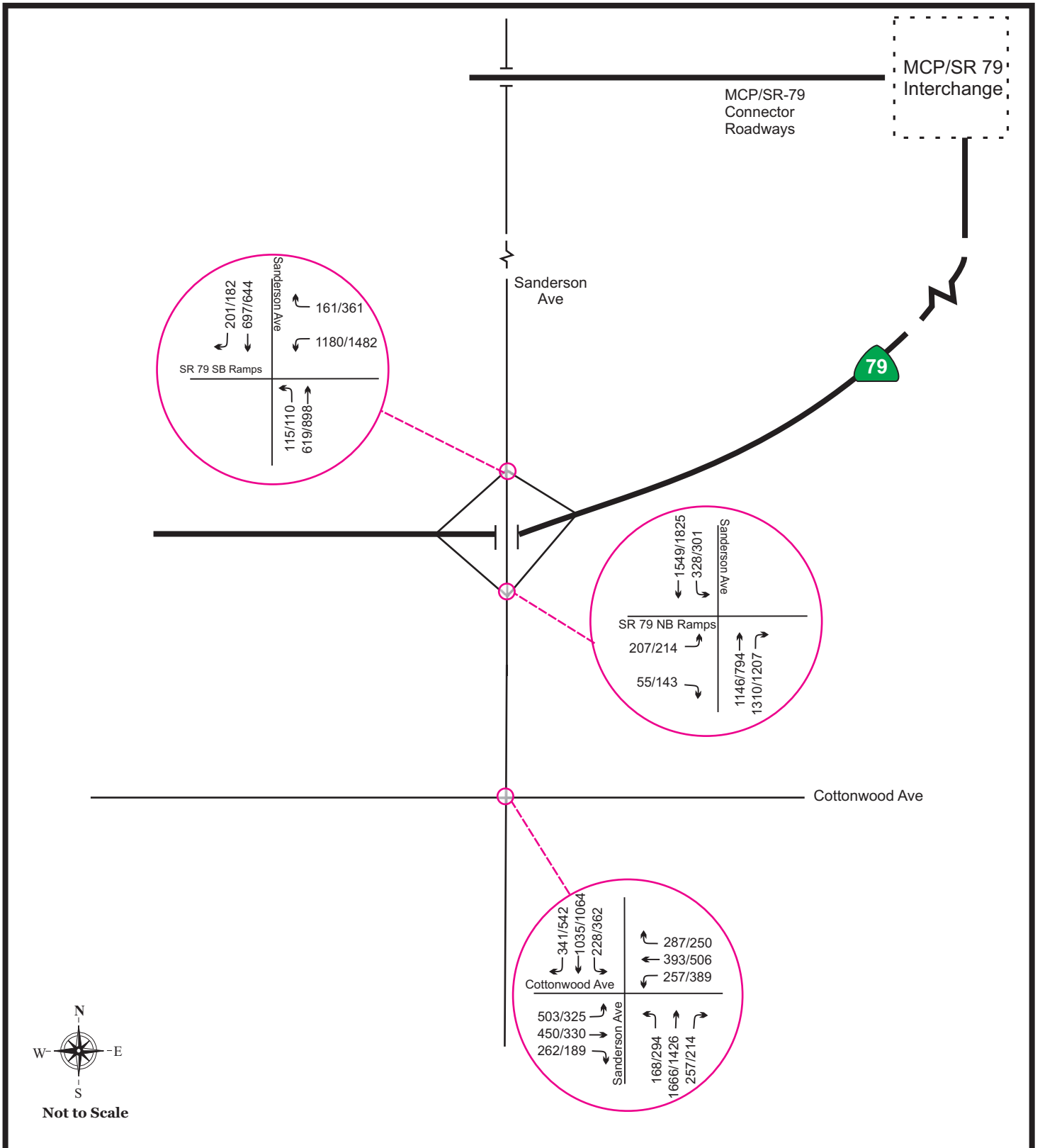

Horizon Year (2040) AM/PM Peak Hour Traffic Intersections - Alternative 4 Modified

Figure 7-23o

XXX/XXX AM/PM Peak Hour



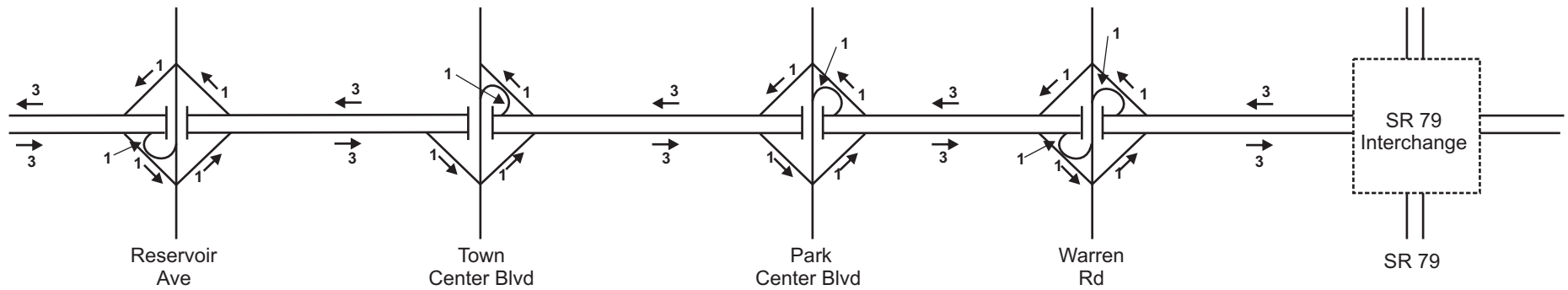
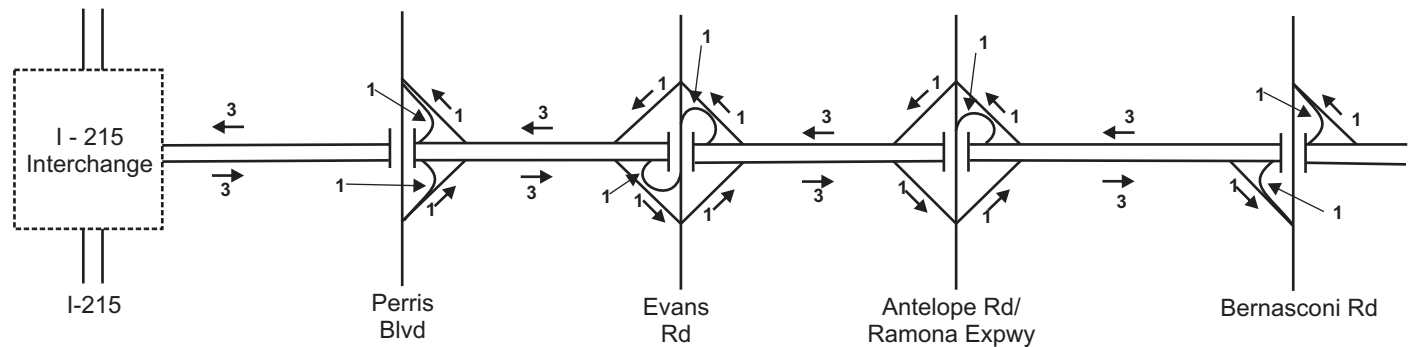

**Horizon Year (2040) Freeway Mainline Lane Geometry
Mid County Parkway - Alternative 5 Modified**

Figure 7-24

Legend

←^x Number of Lanes



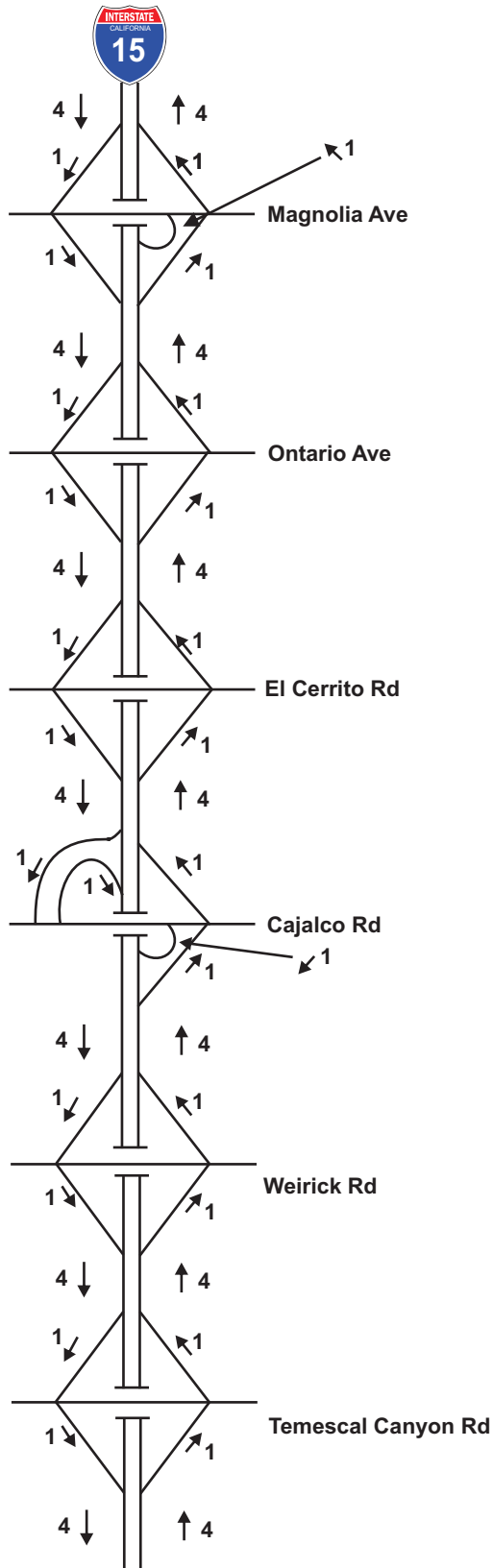

Note:
Two Express Lanes in each direction of travel will be provided in addition to the lanes indicated on I-15.

**Horizon Year (2040) Freeway Mainline Lane Geometry
Interstate 15 - Alternative 5 Modified**

Figure 7-25

Legend

- Direction of Travel
- X : Number of Lanes (Mixed Flow)



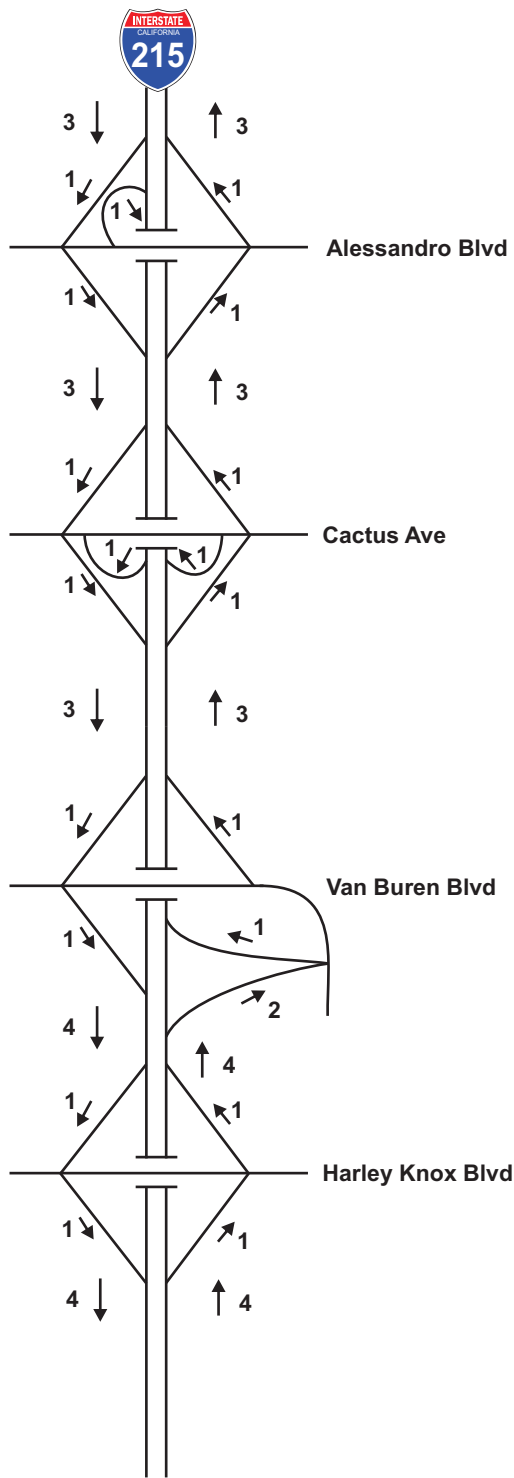

Note:
 One HOV Lane in each direction of travel will be provided in addition to the lanes indicated on I-215.

**Horizon Year (2040)
 Freeway Mainline Lane Geometry
 Interstate 215 - Alternative 5 Modified**

Figure 7-26a

Legend
 → Direction of Travel
 X : Number of Lanes (Mixed Flow)



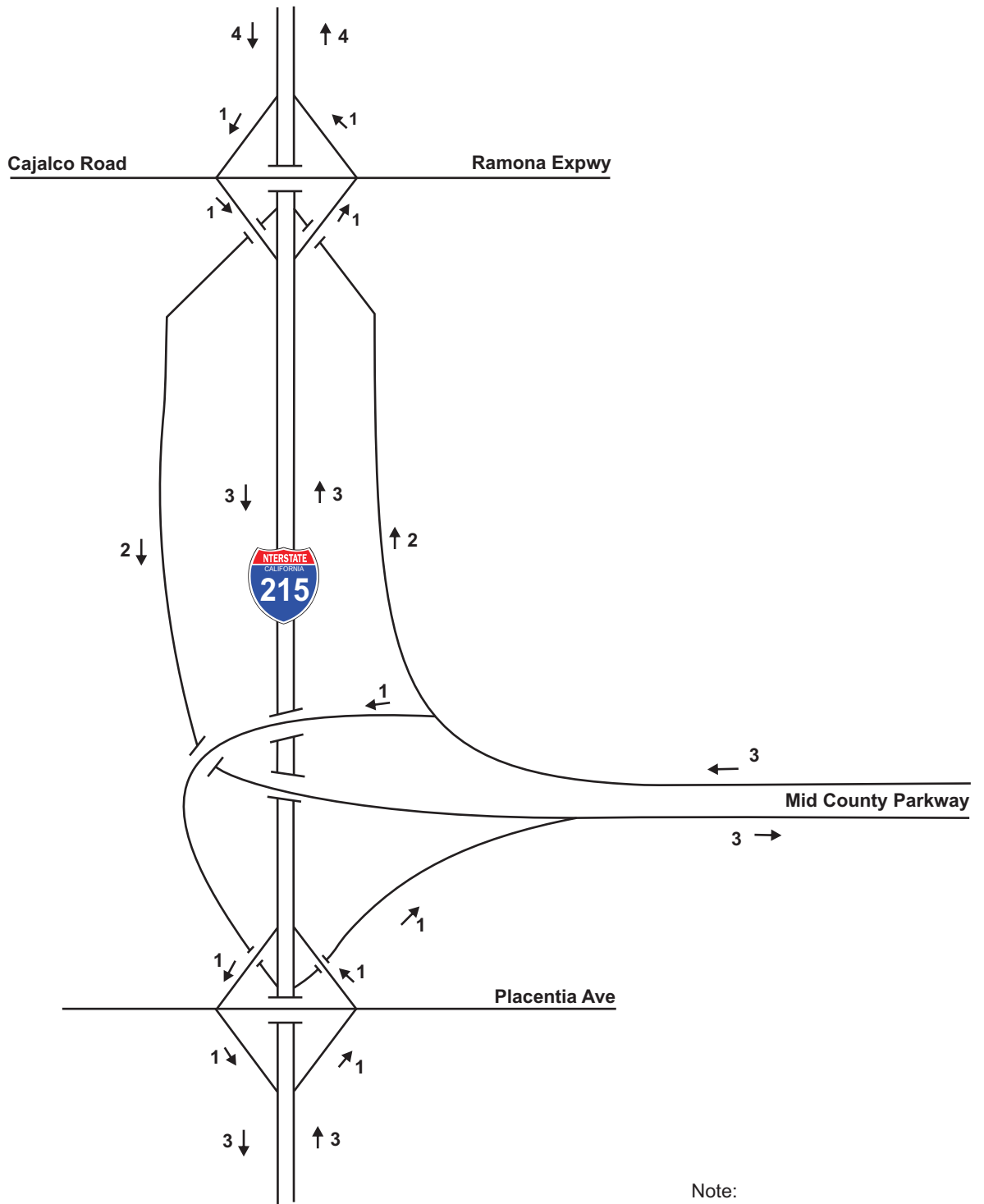

Note:
 One HOV Lane in each direction of travel will be provided in addition to the lanes indicated on I-215.

**Horizon Year (2040)
 Freeway Mainline Lane Geometry
 Interstate 215 - Alternative 5 Modified**

Figure 7-26b

Legend
 → Direction of Travel
 X : Number of Lanes (Mixed Flow)



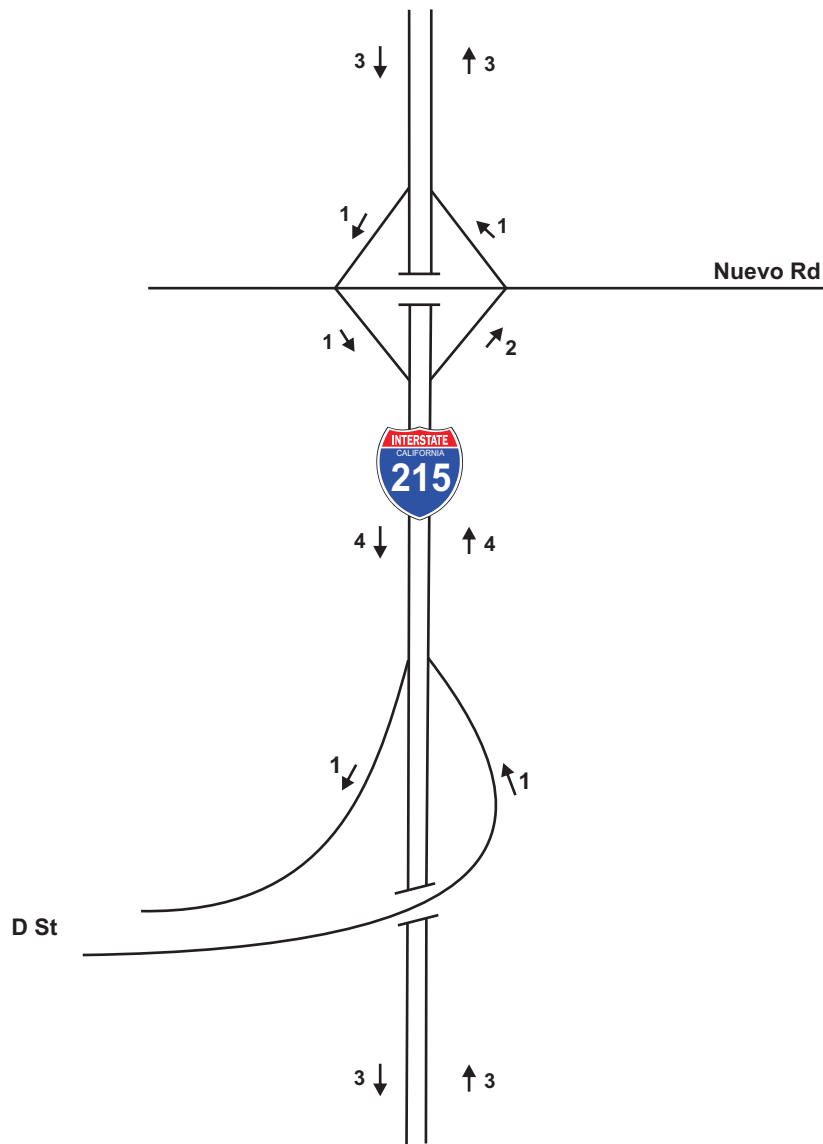

Note:
 One HOV Lane in each direction of travel will be provided North of Nuevo Road in addition to the lanes indicated on I-215.

**Horizon Year (2040)
 Freeway Mainline Lane Geometry
 Interstate 215 - Alternative 5 Modified**

Figure 7-26c

Legend
 → Direction of Travel
 X : Number of Lanes (Mixed Flow)



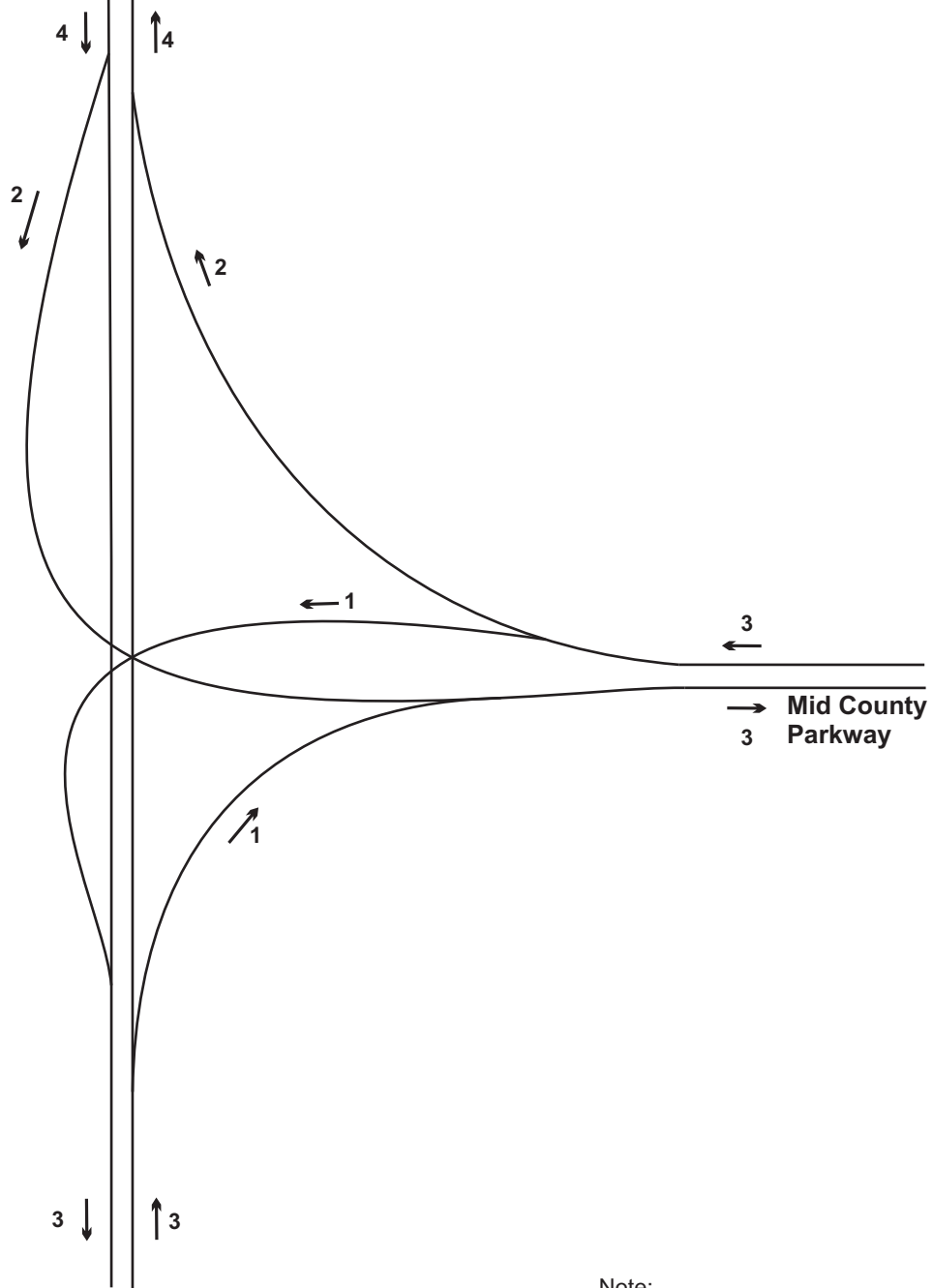

Note:
 One HOV Lane in each direction of travel on I-215 will be provided in addition to the lanes indicated.

**Horizon Year (2040) MCP/I-215 Interchange Area
 Lane Geometry - Alternative 5 Modified**

Figure 7-27

Legend
 → Direction of Travel
 X : Number of Lanes (Mixed Flow)



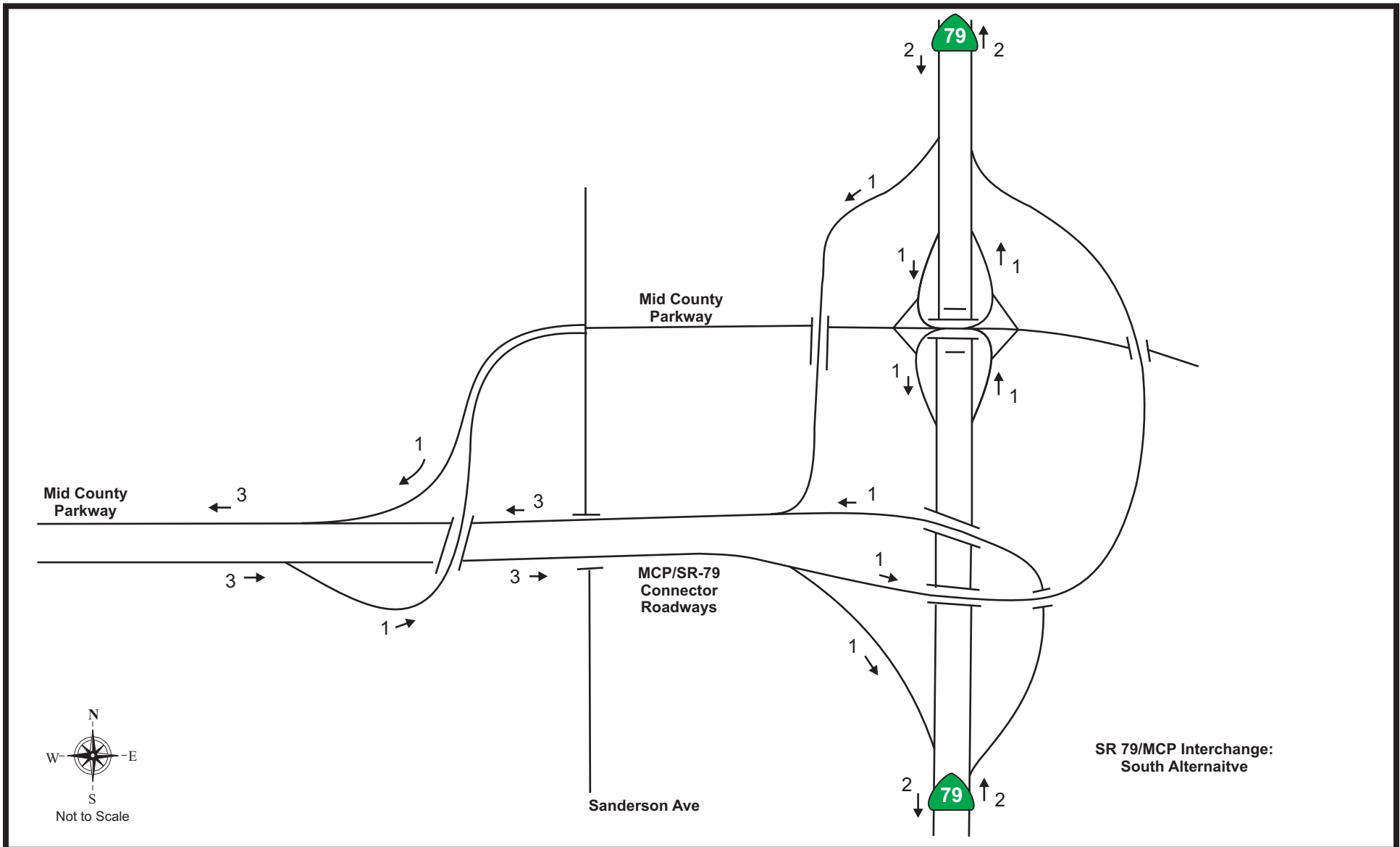

**Horizon Year (2040) MCP/SR-79 Interchange Area
Lane Geometry - Alternative 5 Modified**

Figure 7-28

Legend

← Number of Lanes
X



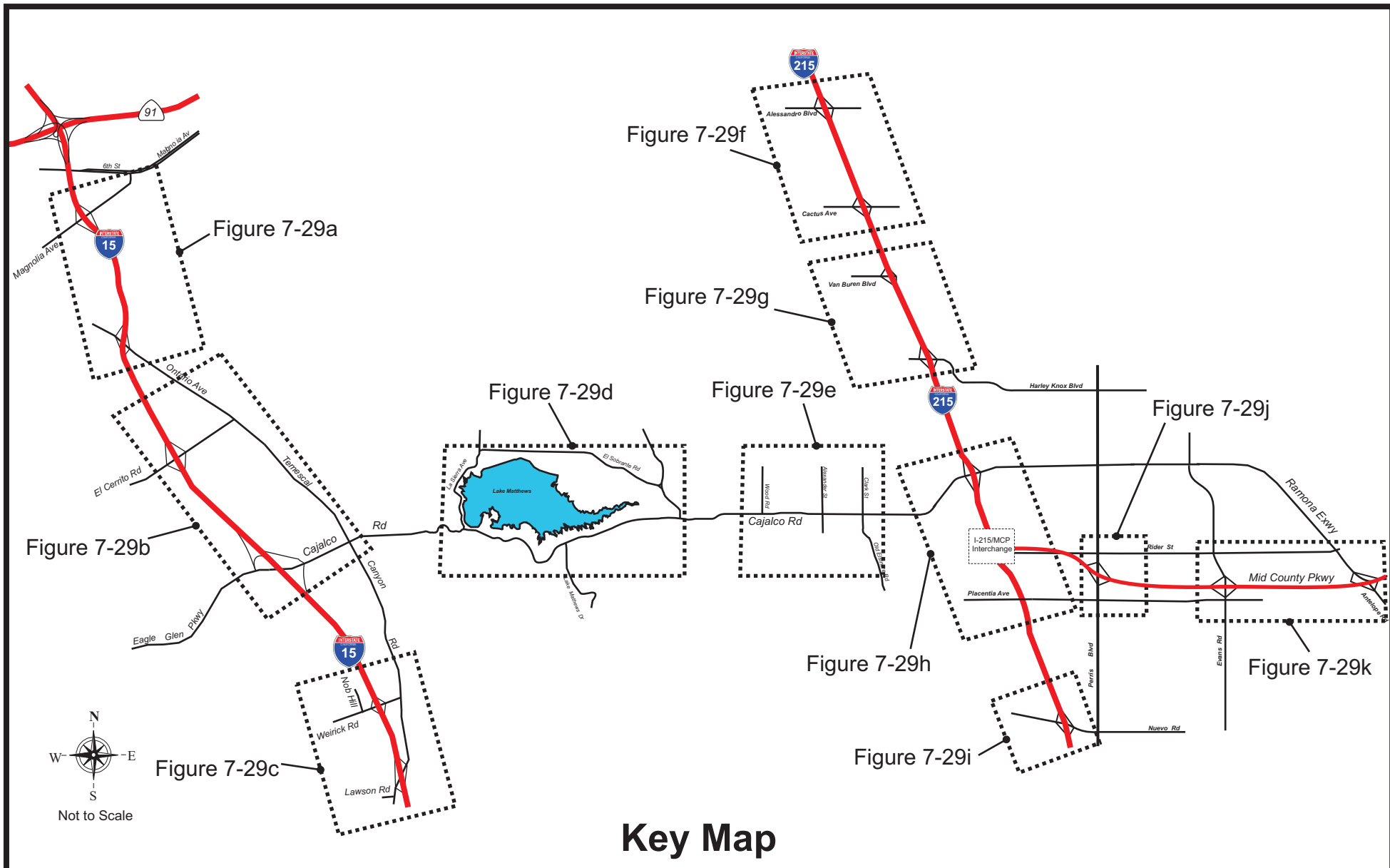

Key Map

Horizon Year (2040) Intersection Lane Geometry Alternative 5 Modified

Figure 7-29

Legend:

 Figure Areas



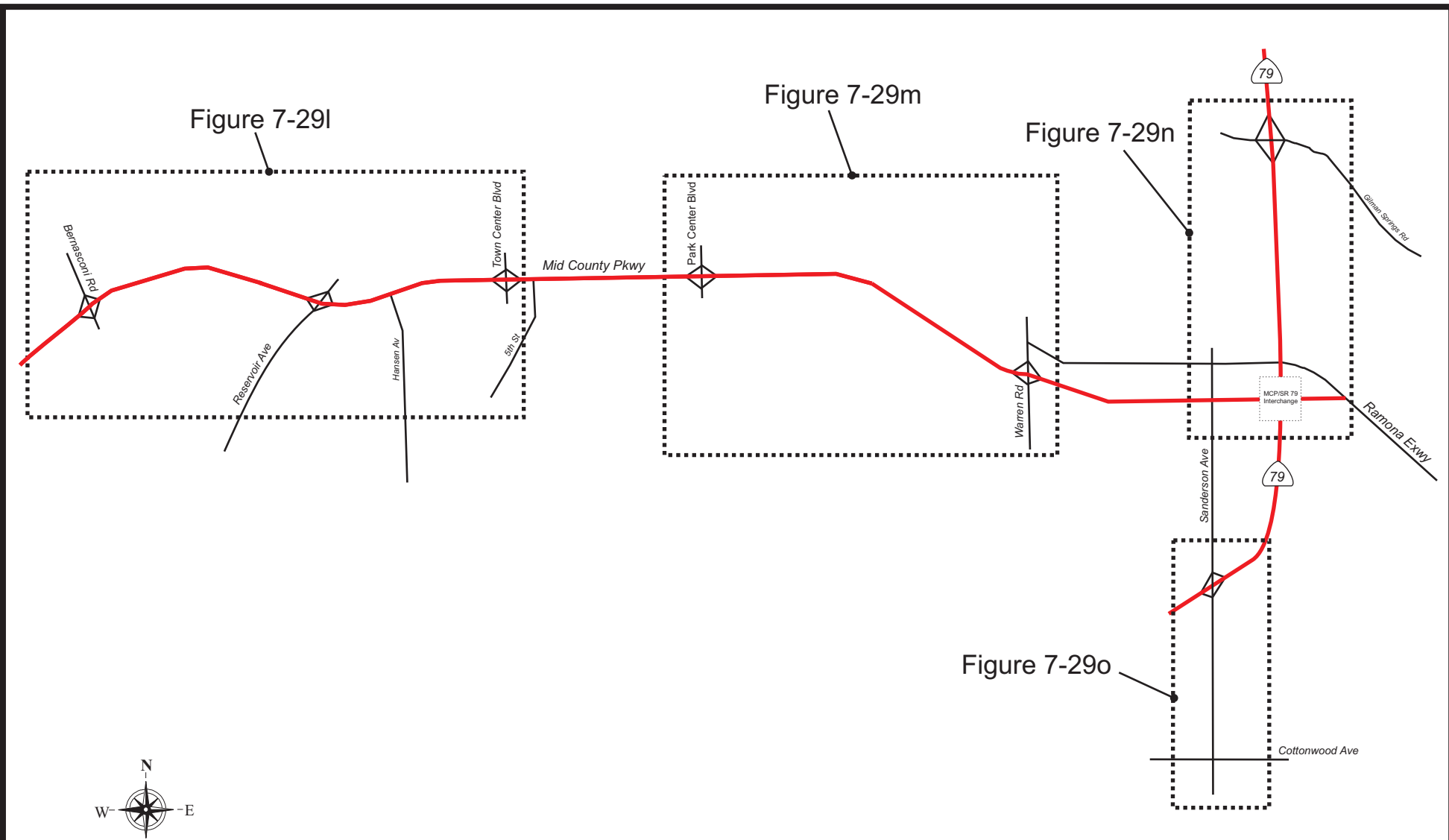

Key Map

**Horizon Year (2040) Intersection Lane Geometry
Alternative 5 Modified**

Figure 7-29 (cont.)

Legend:

 Figure Areas



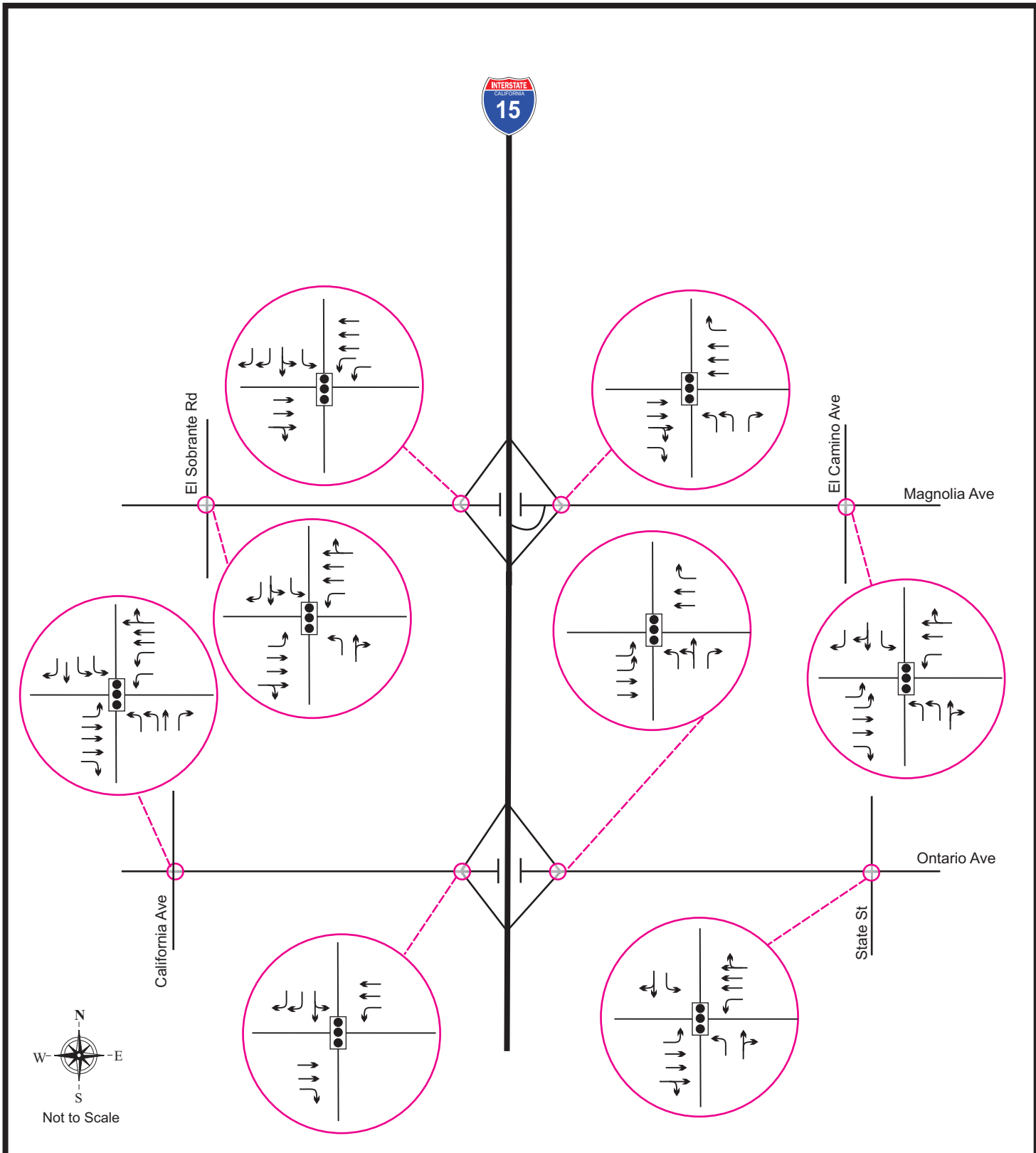

**Horizon Year (2040) Intersection
Lane Geometry - Alternative 5 Modified**

Figure 7-29a

Legend:

-  Signal
-  Traffic Lane



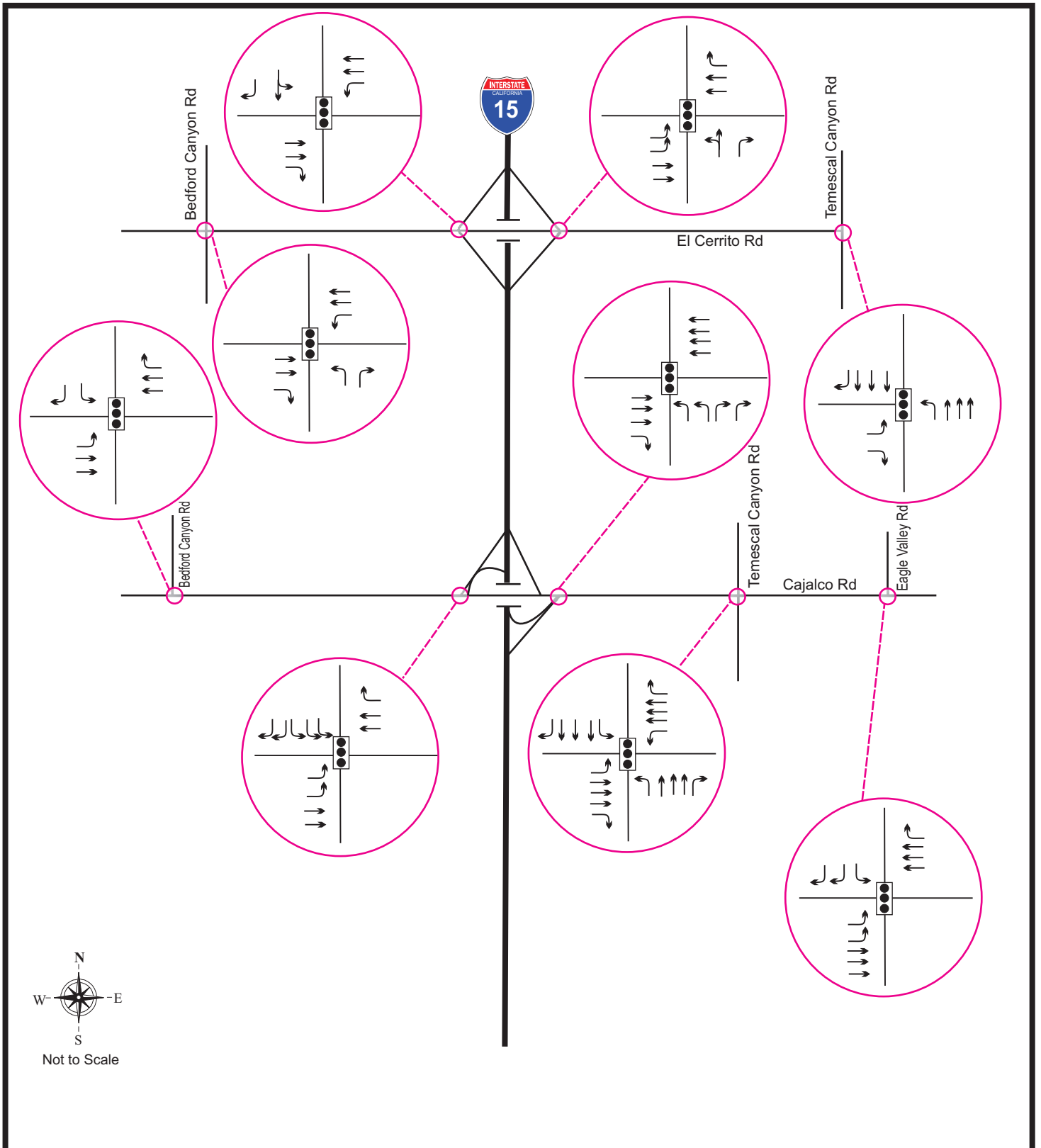

**Horizon Year (2040) Intersection
Lane Geometry - Alternative 5 Modified**

Figure 7-29b

Legend:



Signal



Traffic Lane



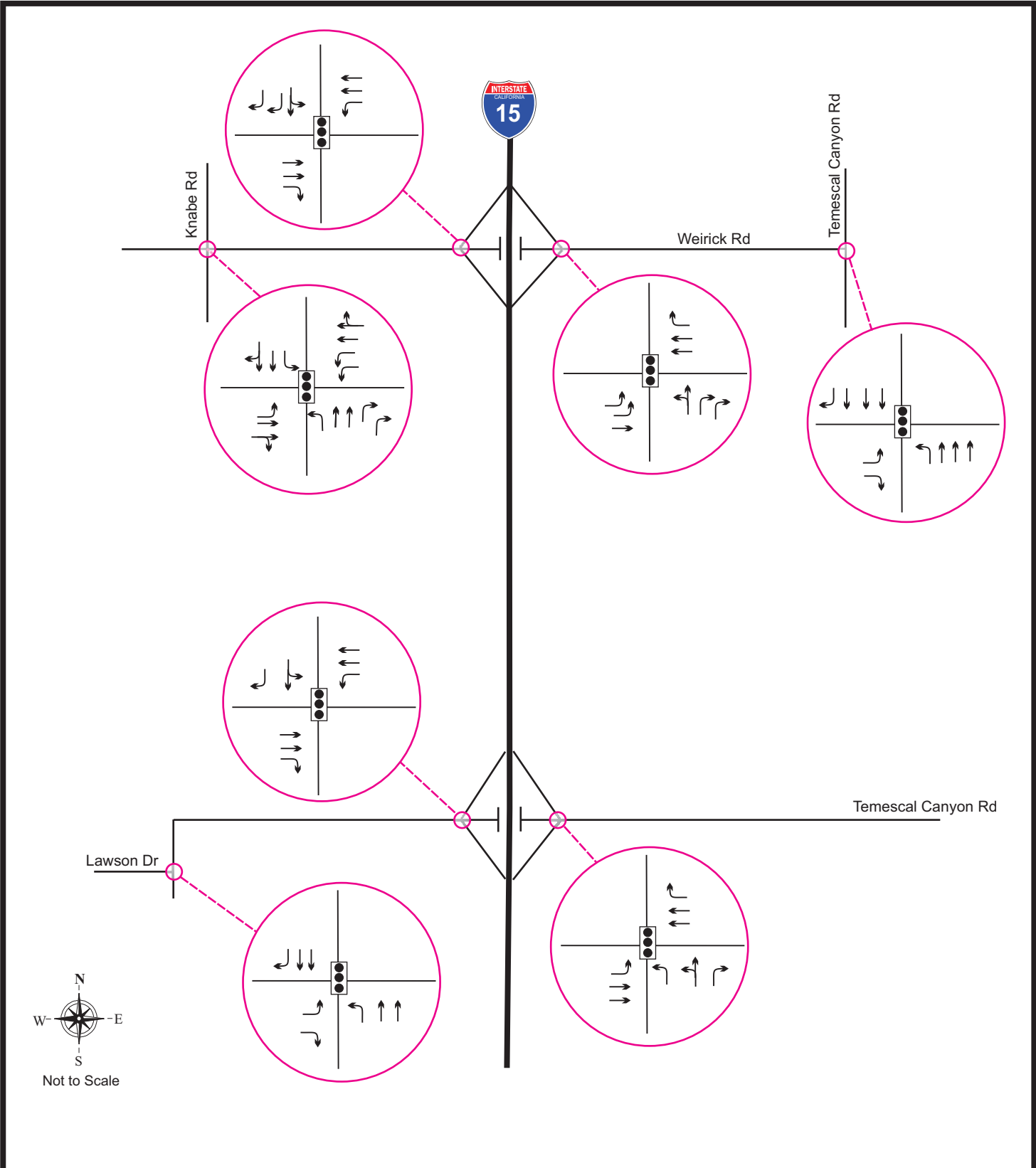

**Horizon Year (2040) Intersection
Lane Geometry - Alternative 5 Modified**

Figure 7-29c

Legend:

-  Signal
-  Traffic Lane



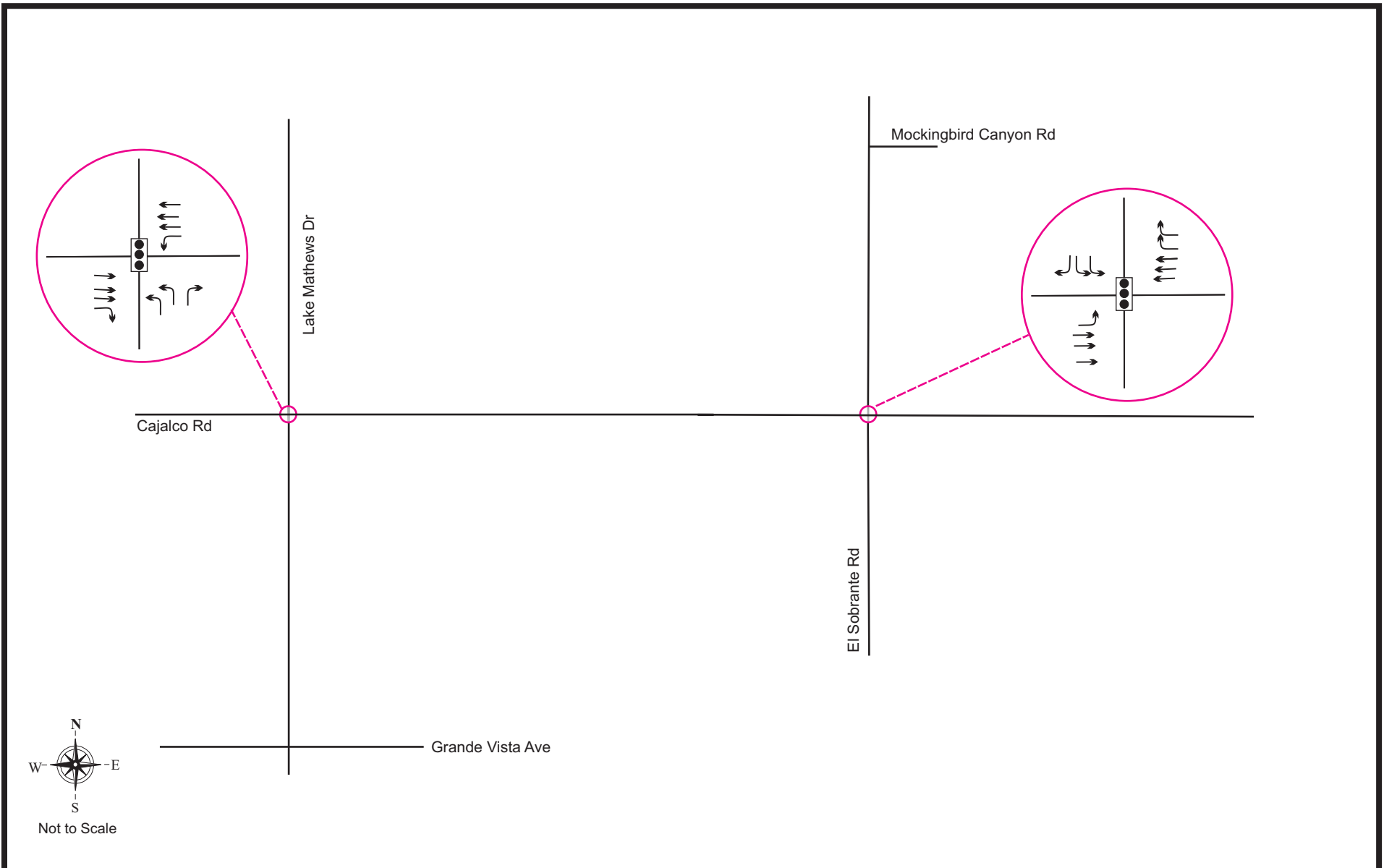

**Horizon Year (2040) Intersection
Lane Geometry - Alternative 5 Modified**

Figure 7-29d

Legend:

-  Signal
-  Traffic Lane



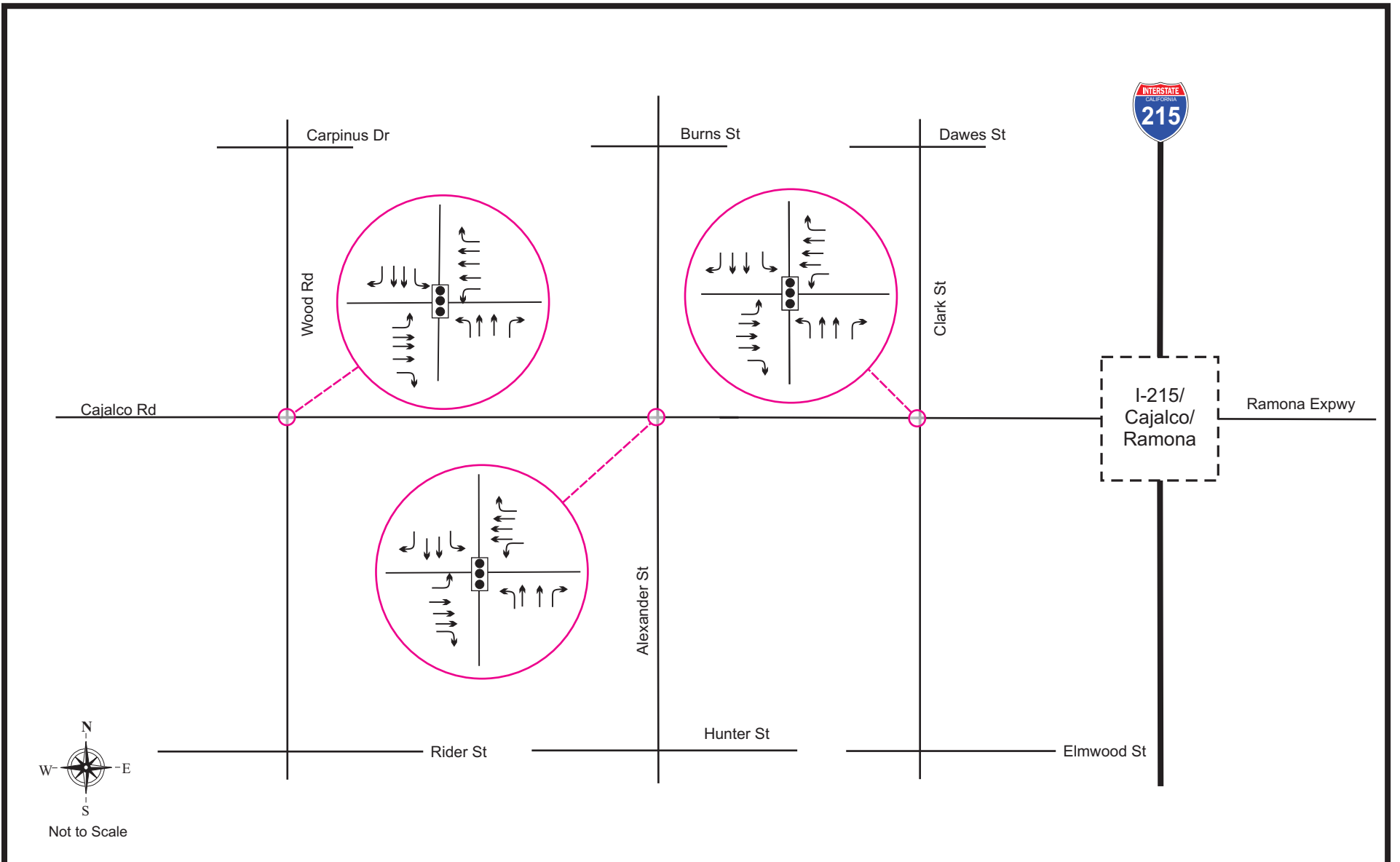

**Horizon Year (2040) Intersection
Lane Geometry - Alternative 5 Modified**

Figure 7-29e

Legend:

-  Signal
-  Traffic Lane



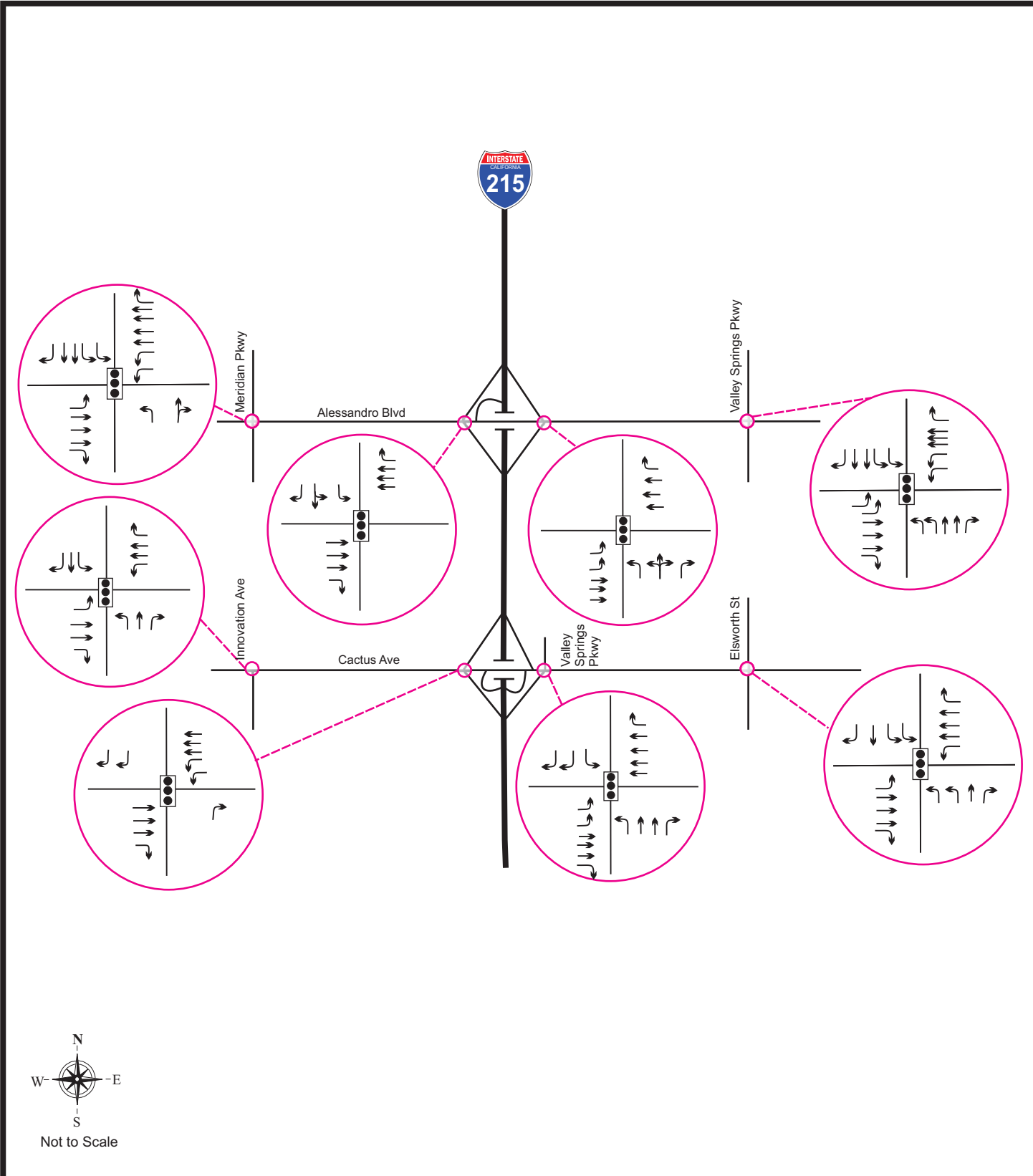

**Horizon Year (2040) Intersection
Lane Geometry - Alternative 5 Modified**

Figure 7-29f

Legend:

-  Signal
-  Traffic Lane



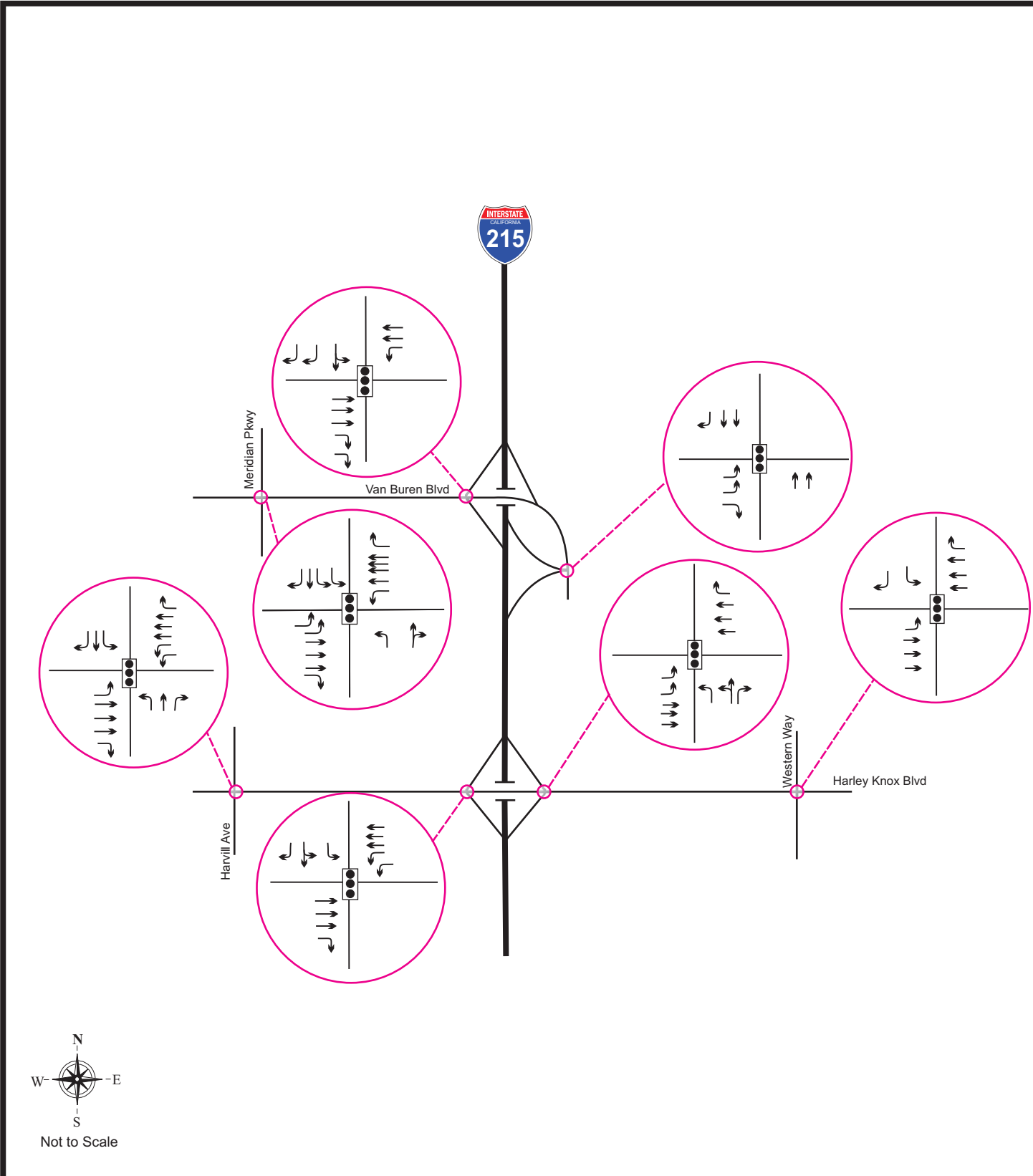

**Horizon Year (2040) Intersection
Lane Geometry - Alternative 5 Modified**

Figure 7-29g

Legend:

-  Signal
-  Traffic Lane



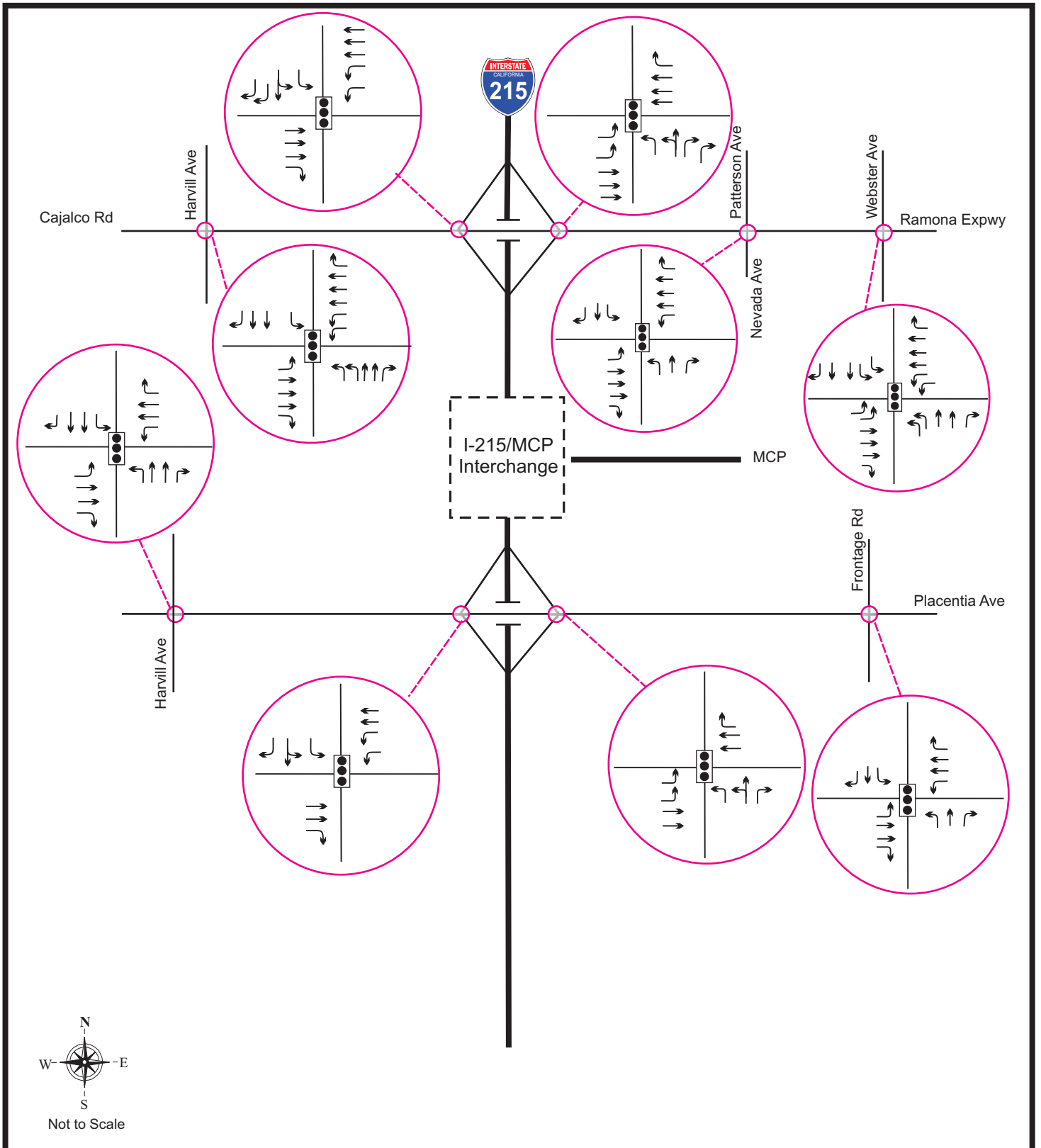

**Horizon Year (2040) Intersection
Lane Geometry - Alternative 5 Modified**

Figure 7-29h

Legend:



Signal



Traffic Lane



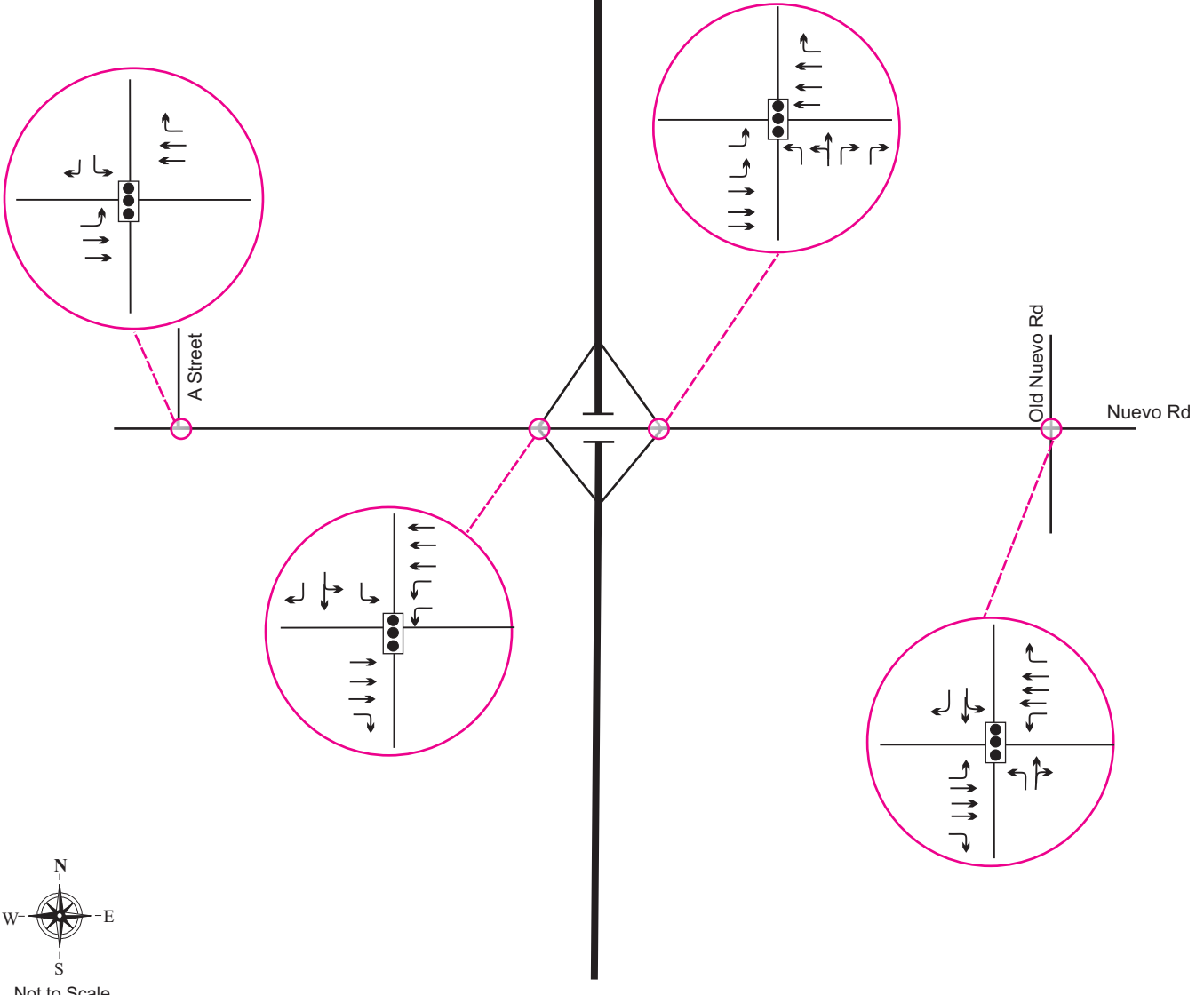

**Horizon Year (2040) Intersection
Lane Geometry - Alternative 5 Modified**

Figure 7-29i

Legend:

-  Signal
-  Traffic Lane



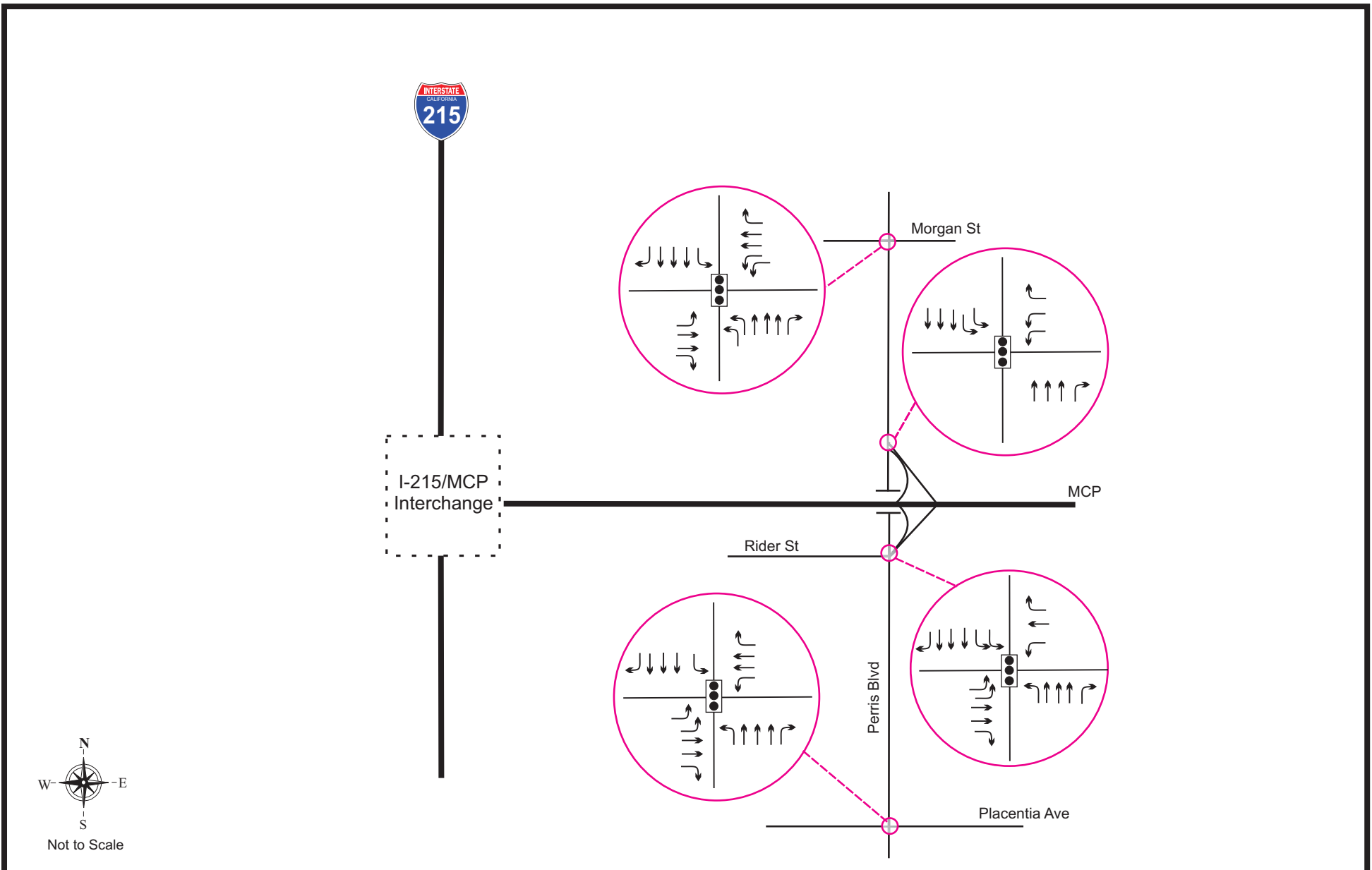

**Horizon Year (2040) Intersection
Lane Geometry - Alternative 5 Modified**

Figure 7-29j

Legend:

-  Signal
-  Traffic Lane



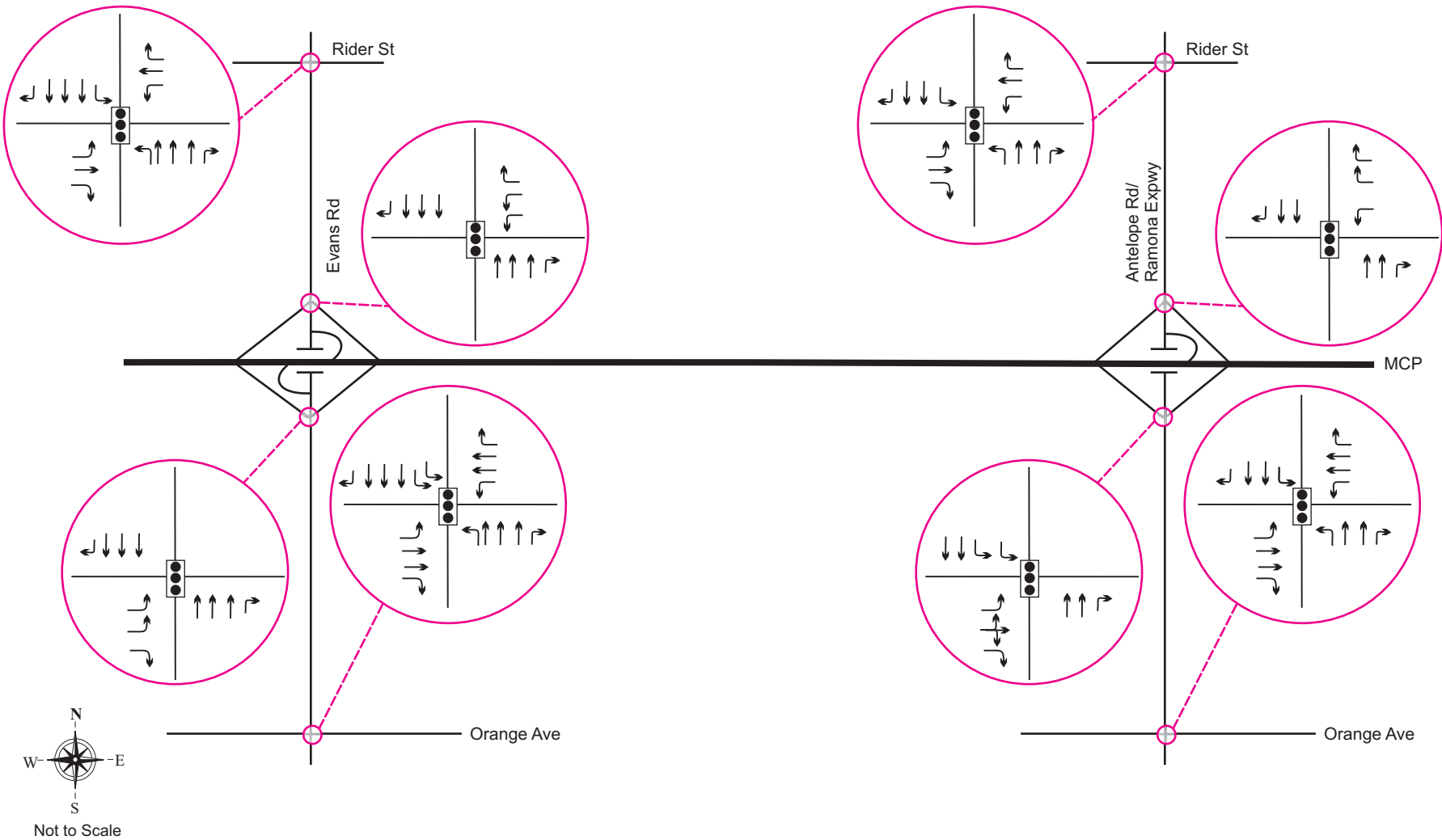

**Horizon Year (2040) Intersection
Lane Geometry - Alternative 5 Modified**

Figure 7-29k

Legend:

-  Signal
-  Traffic Lane



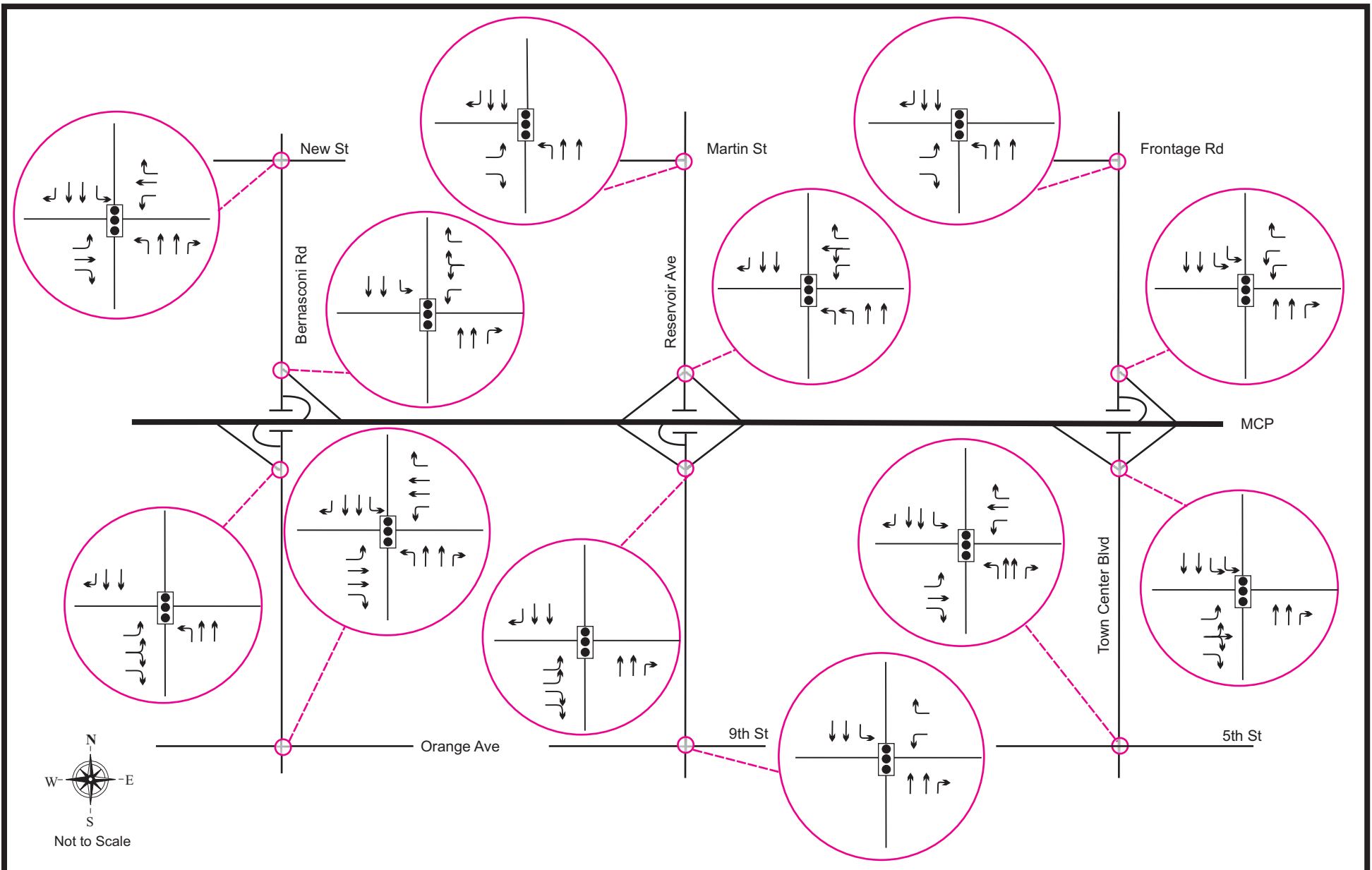

**Horizon Year (2040) Intersection
Lane Geometry - Alternative 5 Modified**

Figure 7-29I

Legend:

-  Signal
-  Traffic Lane



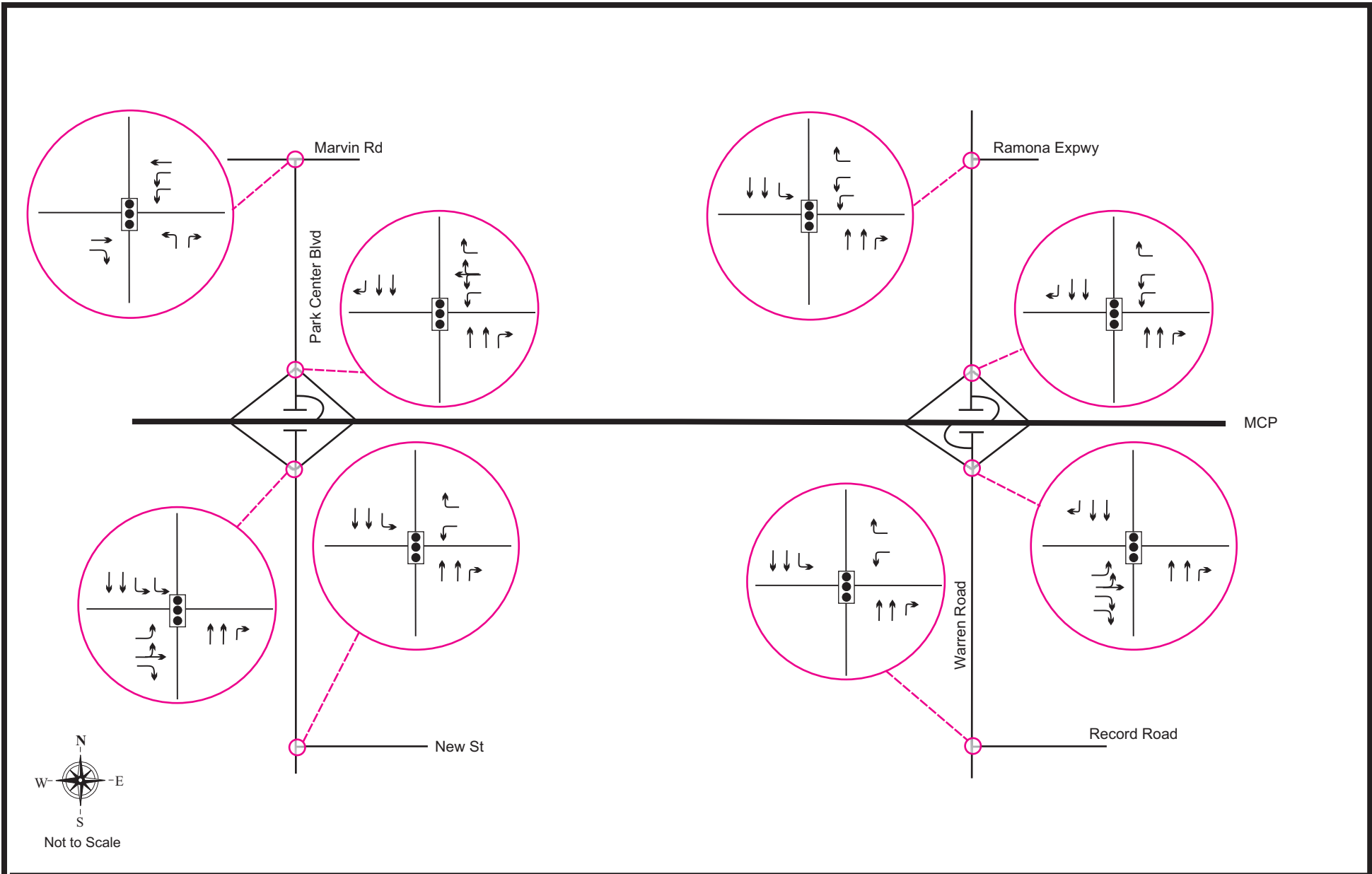

**Horizon Year (2040) Intersection
Lane Geometry - Alternative 5 Modified**

Figure 7-29m

Legend:

-  Signal
-  Traffic Lane



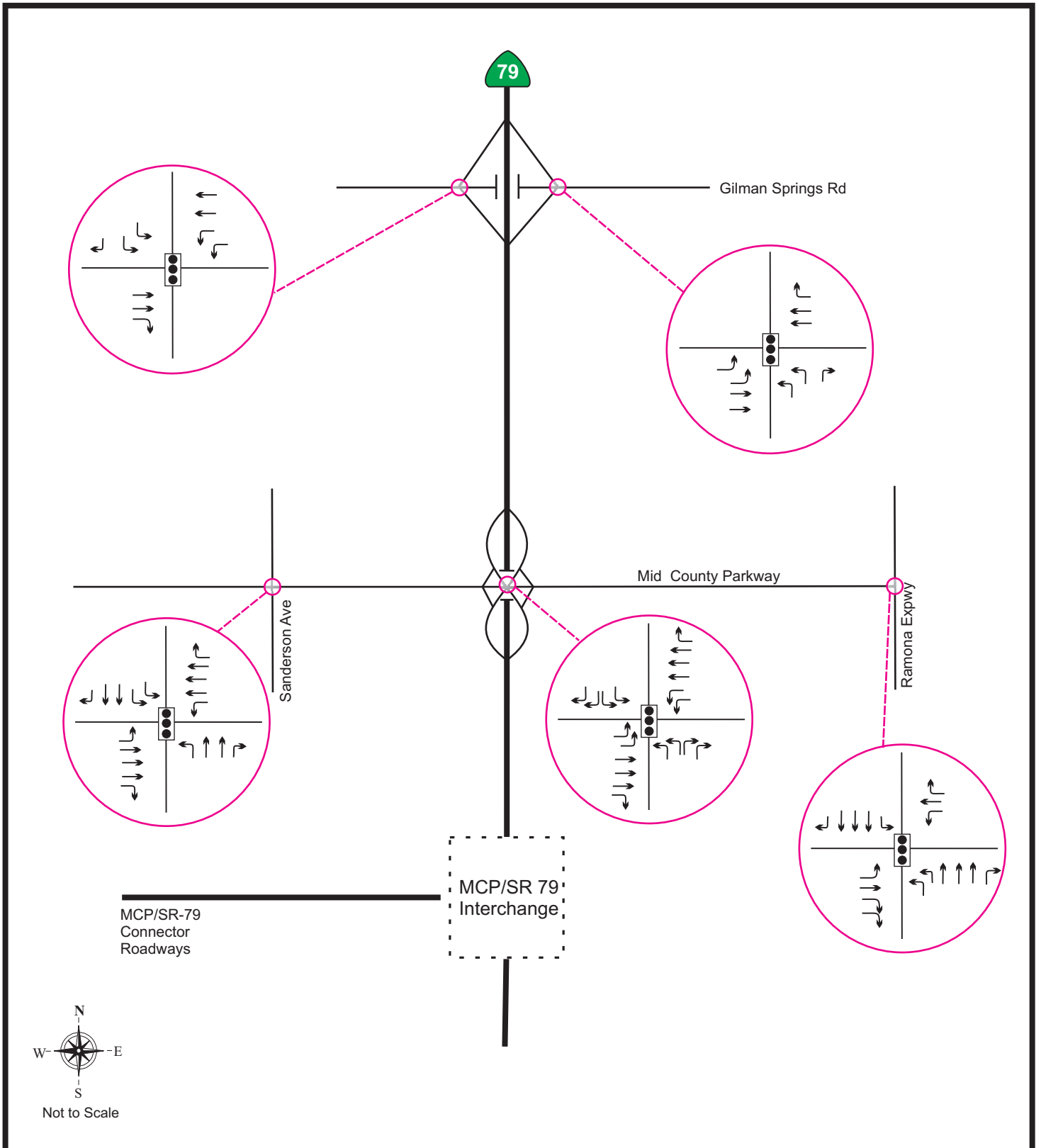

**Horizon Year (2040) Intersection
Lane Geometry - Alternative 5 Modified**

Figure 7-29n

Legend:

-  Signal
-  Traffic Lane



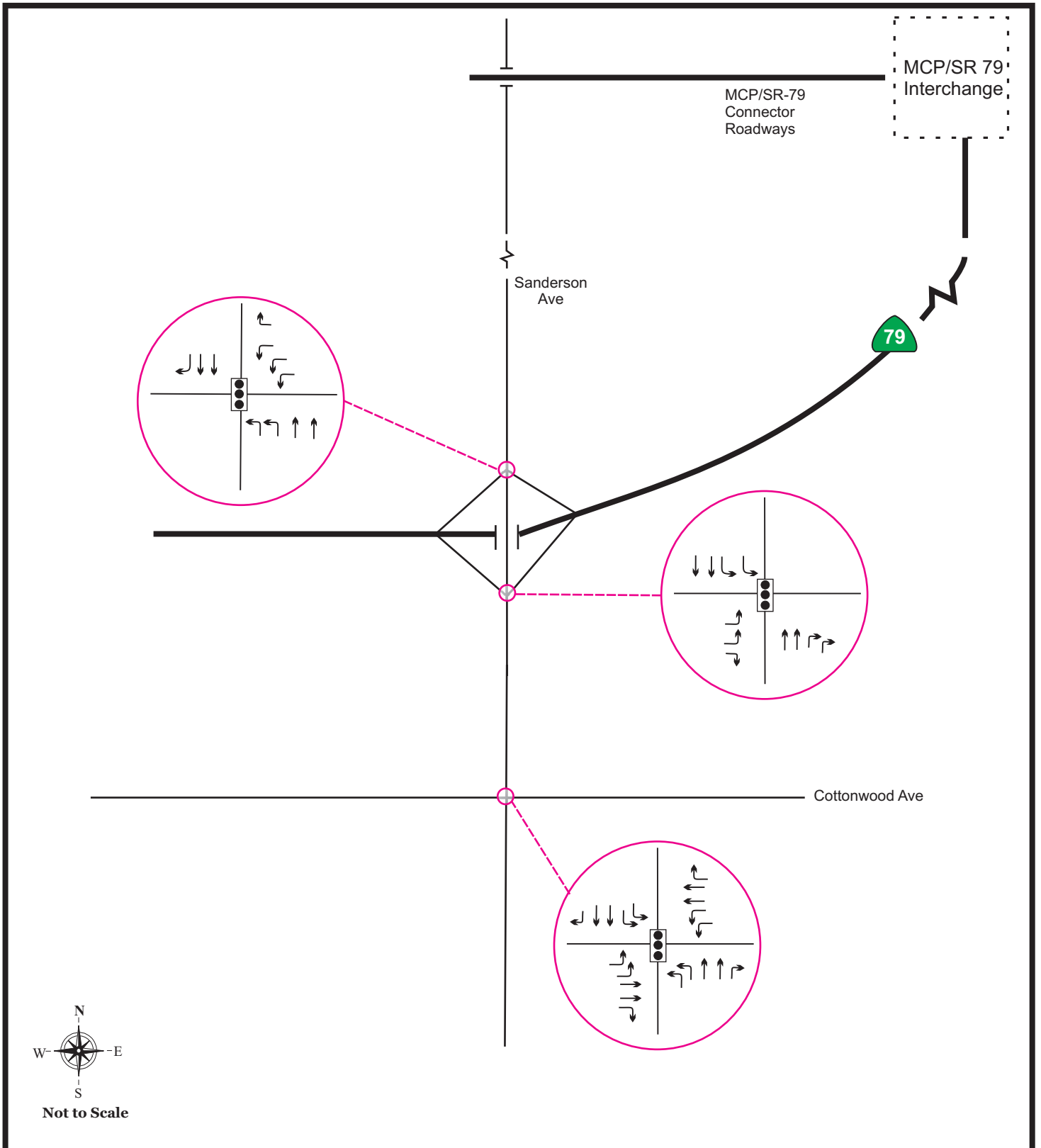

**Horizon Year (2040) Intersection
Lane Geometry - Alternative 5 Modified**

Figure 7-29o

Legend:



Signal



Traffic Lane



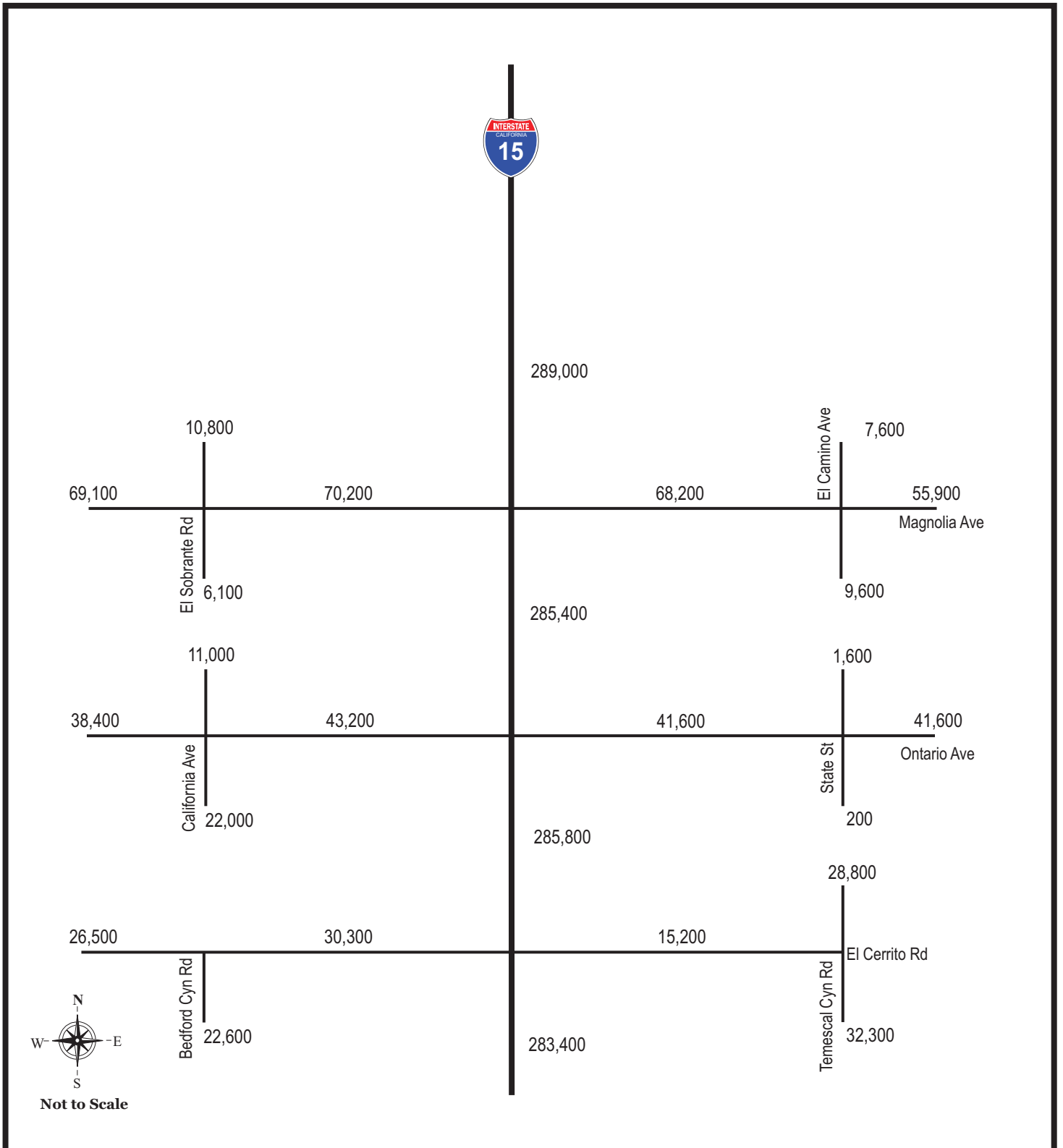

Horizon Year (2040) ADT - Freeway and Street Segments MCP Area - Alternative 5 Modified

Figure 7-30a

Legend:

XX,XXX Average Daily Traffic



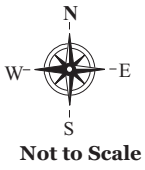
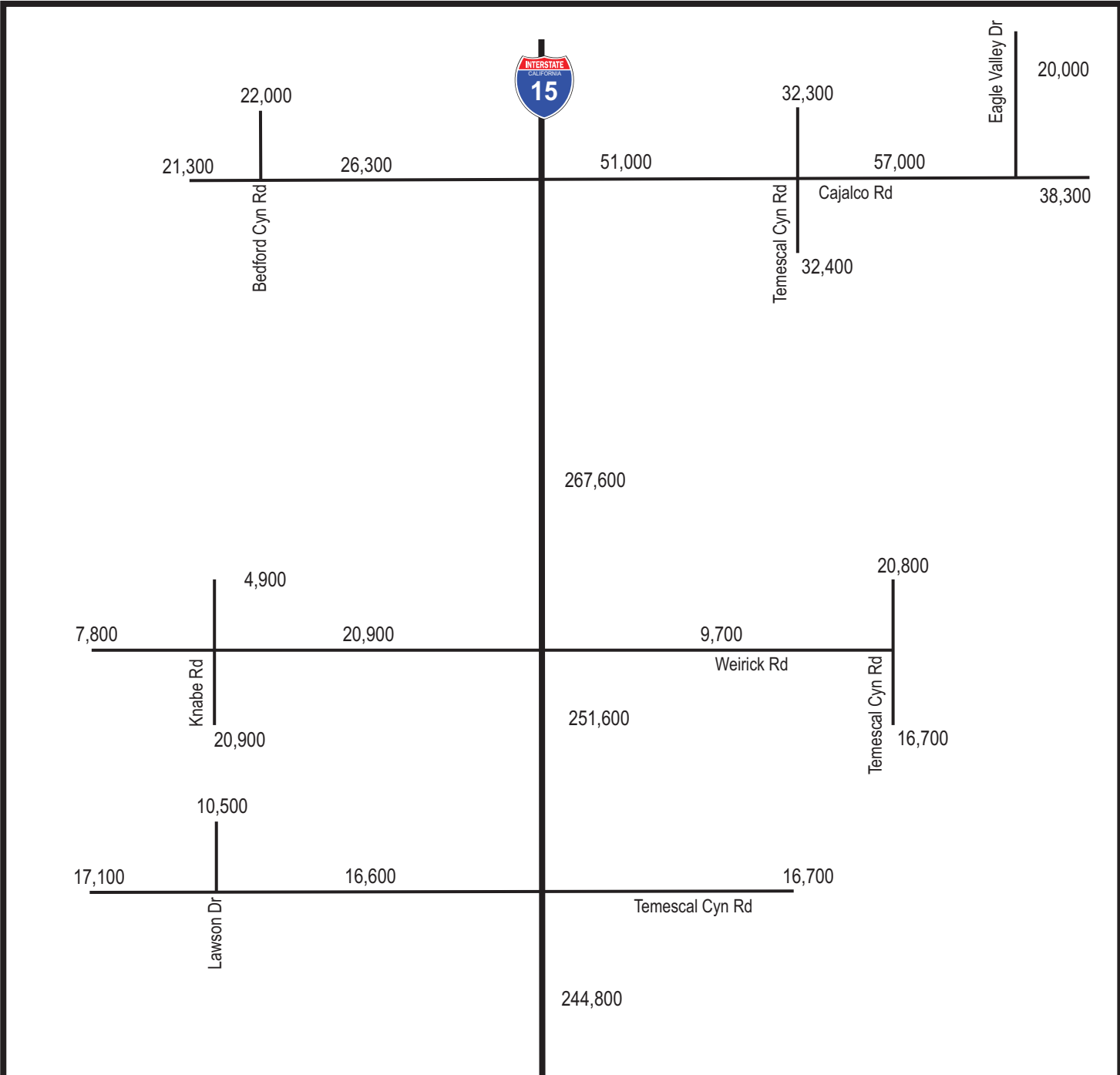

Horizon Year (2040) ADT - Freeway and Street Segments MCP Area - Alternative 5 Modified

Figure 7-30b

Legend:
 XX,XXX Average Daily Traffic



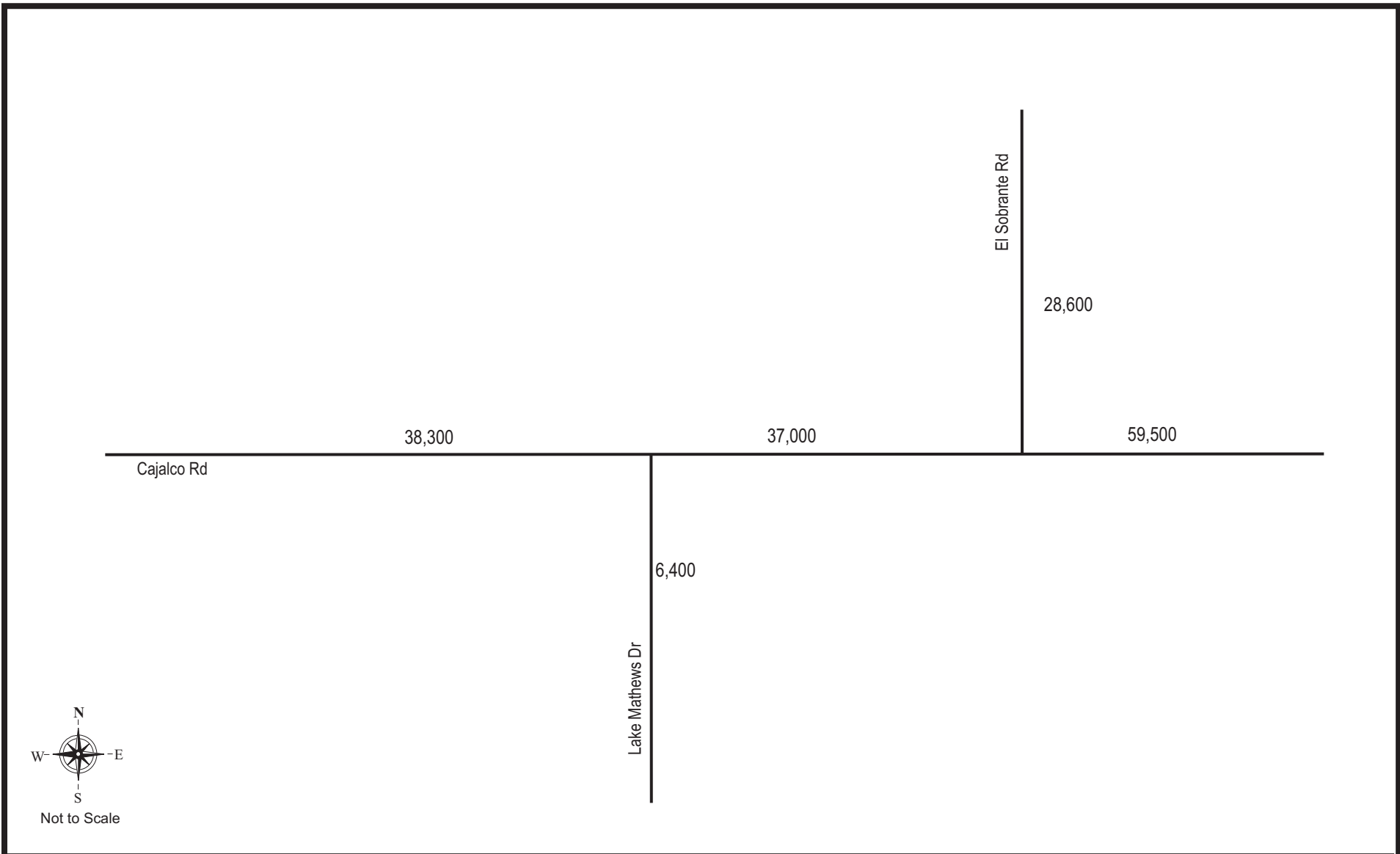

Horizon Year (2040) ADT - Freeway and Street Segments MCP Area - Alternative 5 Modified

Figure 7-30c

Legend:

XX,XXX Average Daily Traffic



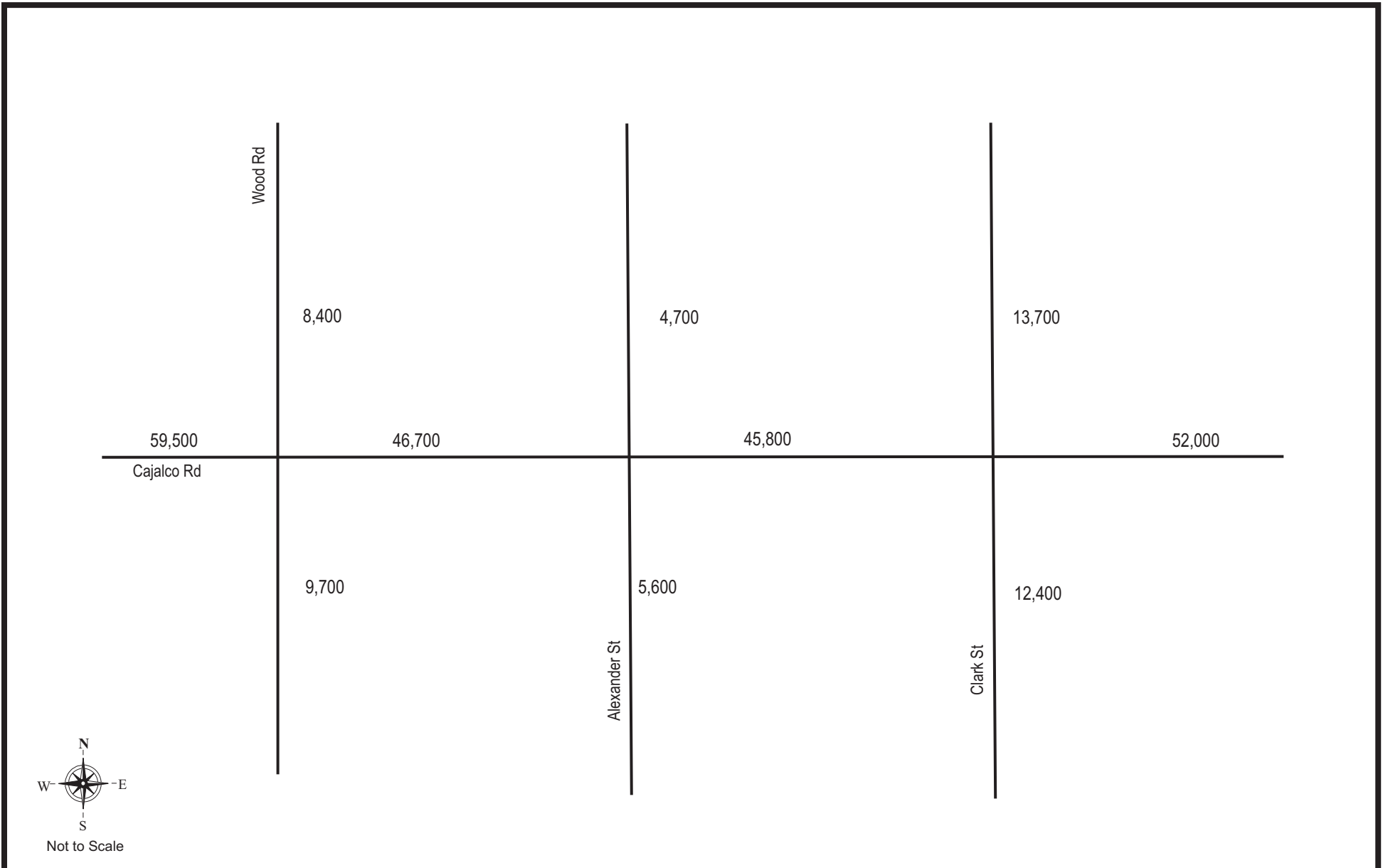

Horizon Year (2040) ADT - Freeway and Street Segments MCP Area - Alternative 5 Modified

Figure 7-30d

Legend:

XX,XXX Average Daily Traffic



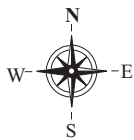
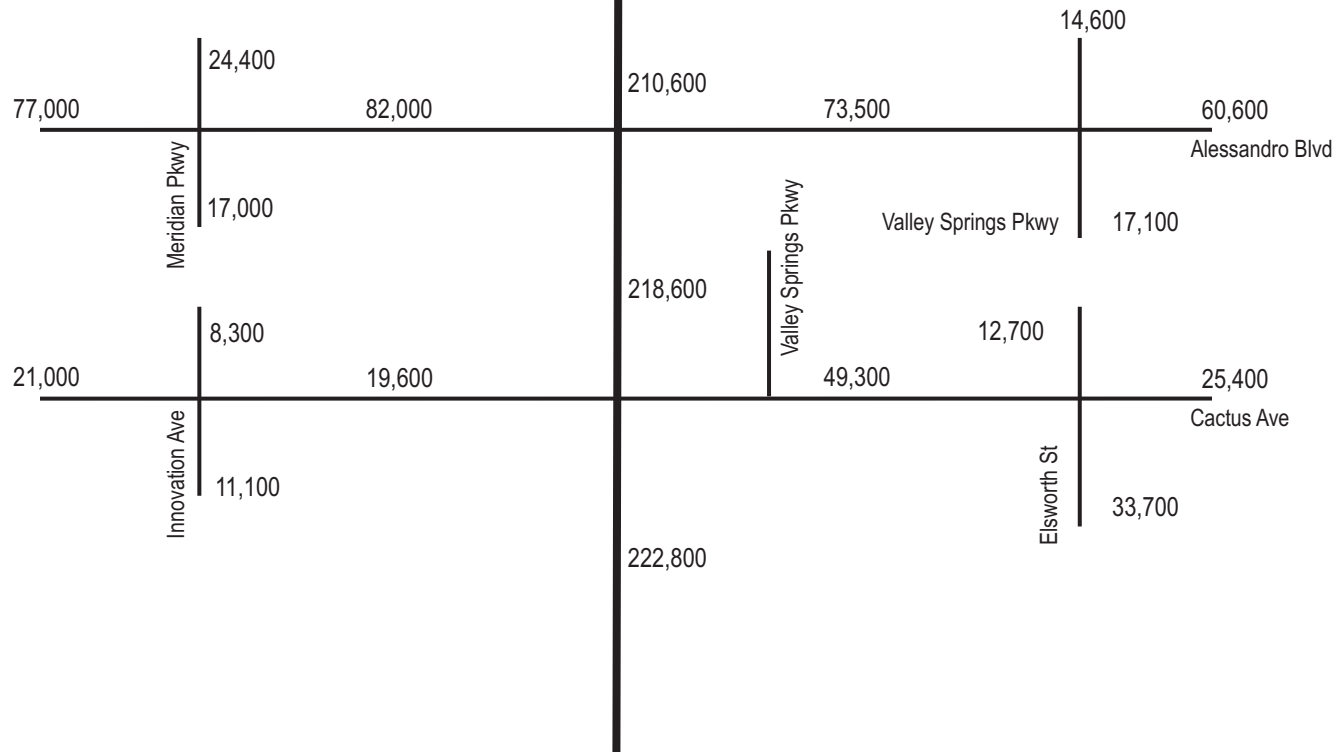

Not to Scale

Horizon Year (2040) ADT - Freeway and Street Segments MCP Area - Alternative 5 Modified

Figure 7-30e

Legend:

XX,XXX Average Daily Traffic





Not to Scale

Horizon Year (2040) ADT - Freeway and Street Segments MCP Area - Alternative 5 Modified

Figure 7-30f

Legend:

XX,XXX Average Daily Traffic



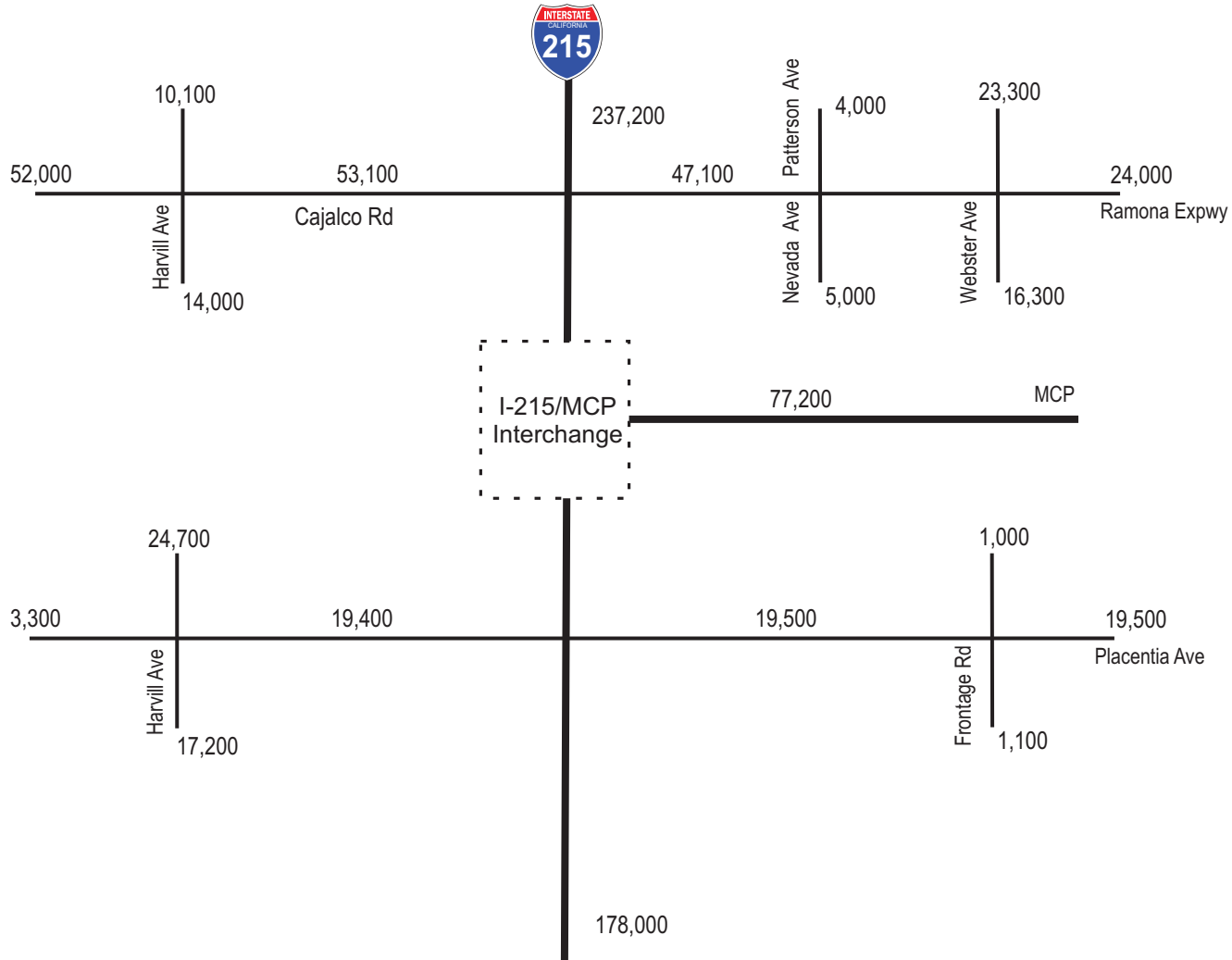

Horizon Year (2040) ADT - Freeway and Street Segments MCP Area - Alternative 5 Modified

Figure 7-30g

Legend:

XX,XXX Average Daily Traffic



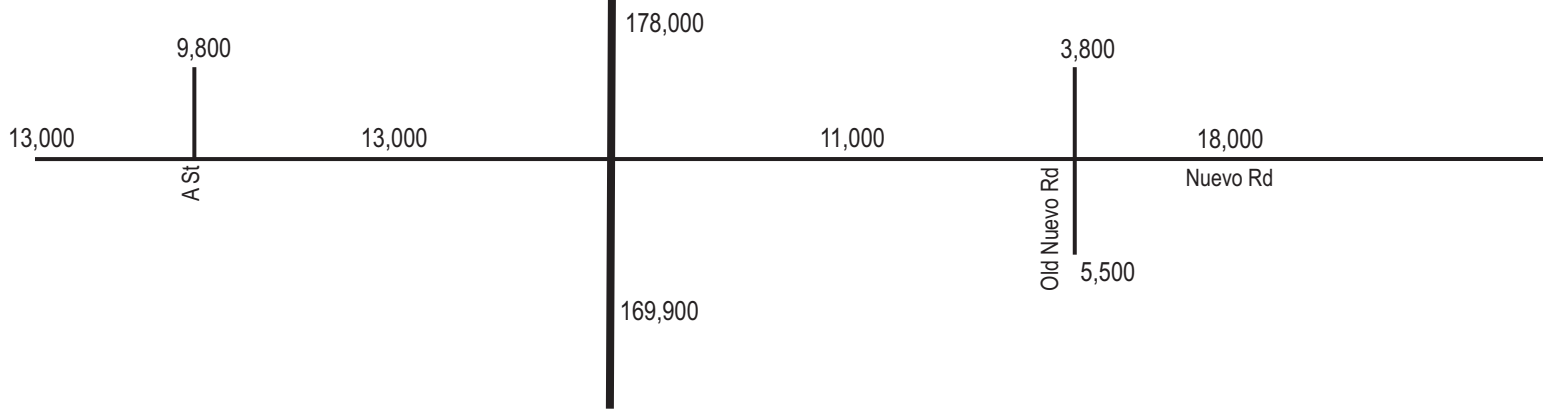

Not to Scale

Horizon Year (2040) ADT - Freeway and Street Segments MCP Area - Alternative 5 Modified

Figure 7-30h

Legend:

XX,XXX Average Daily Traffic



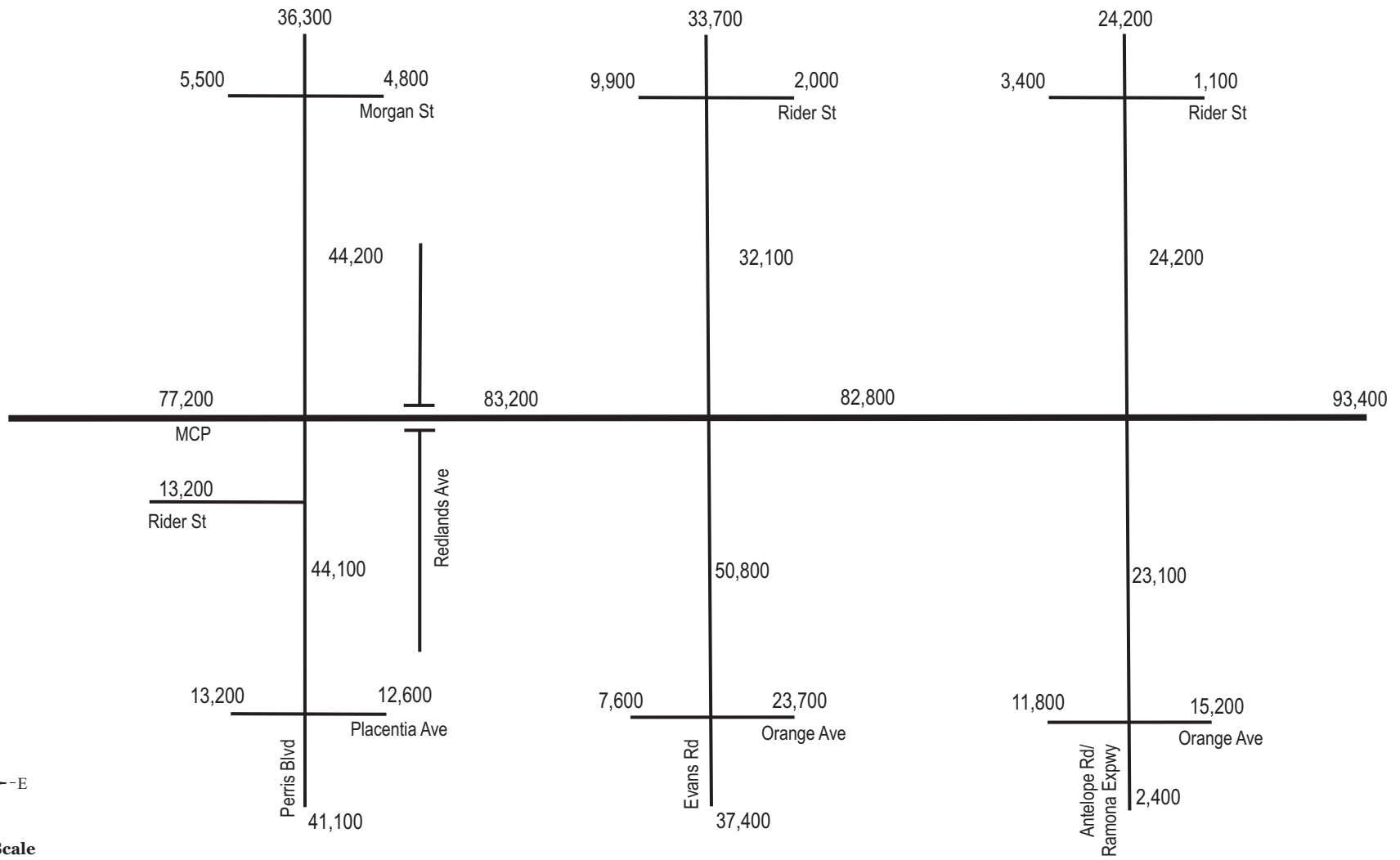

Horizon Year (2040) ADT - Freeway and Street Segments MCP Area - Alternative 5 Modified

Figure 7-30i

Legend:

XX,XXX Average Daily Traffic



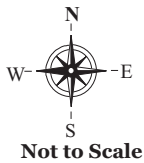
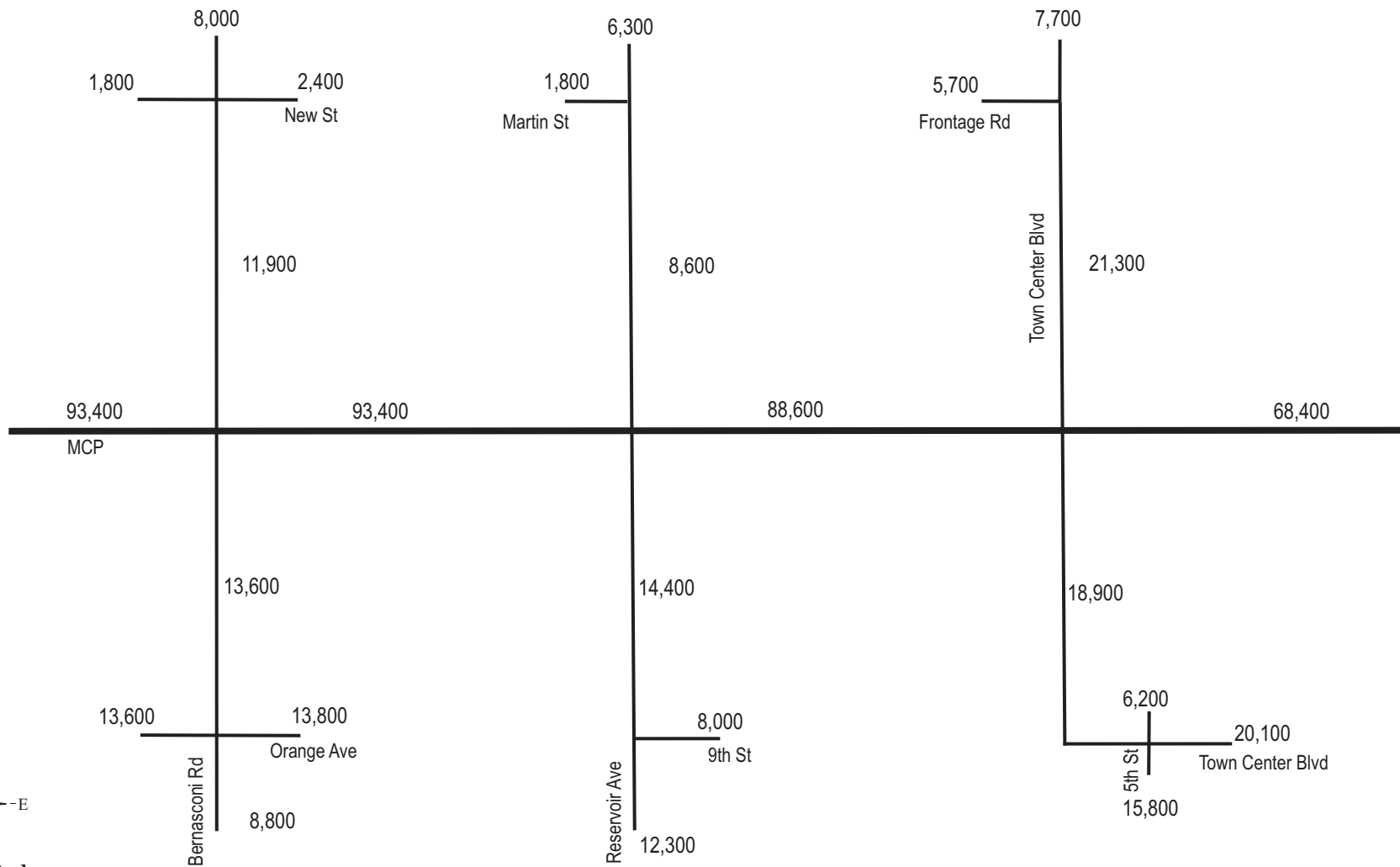

Horizon Year (2040) ADT - Freeway and Street Segments MCP Area - Alternative 5 Modified

Figure 7-30j

Legend:

XX,XXX Average Daily Traffic



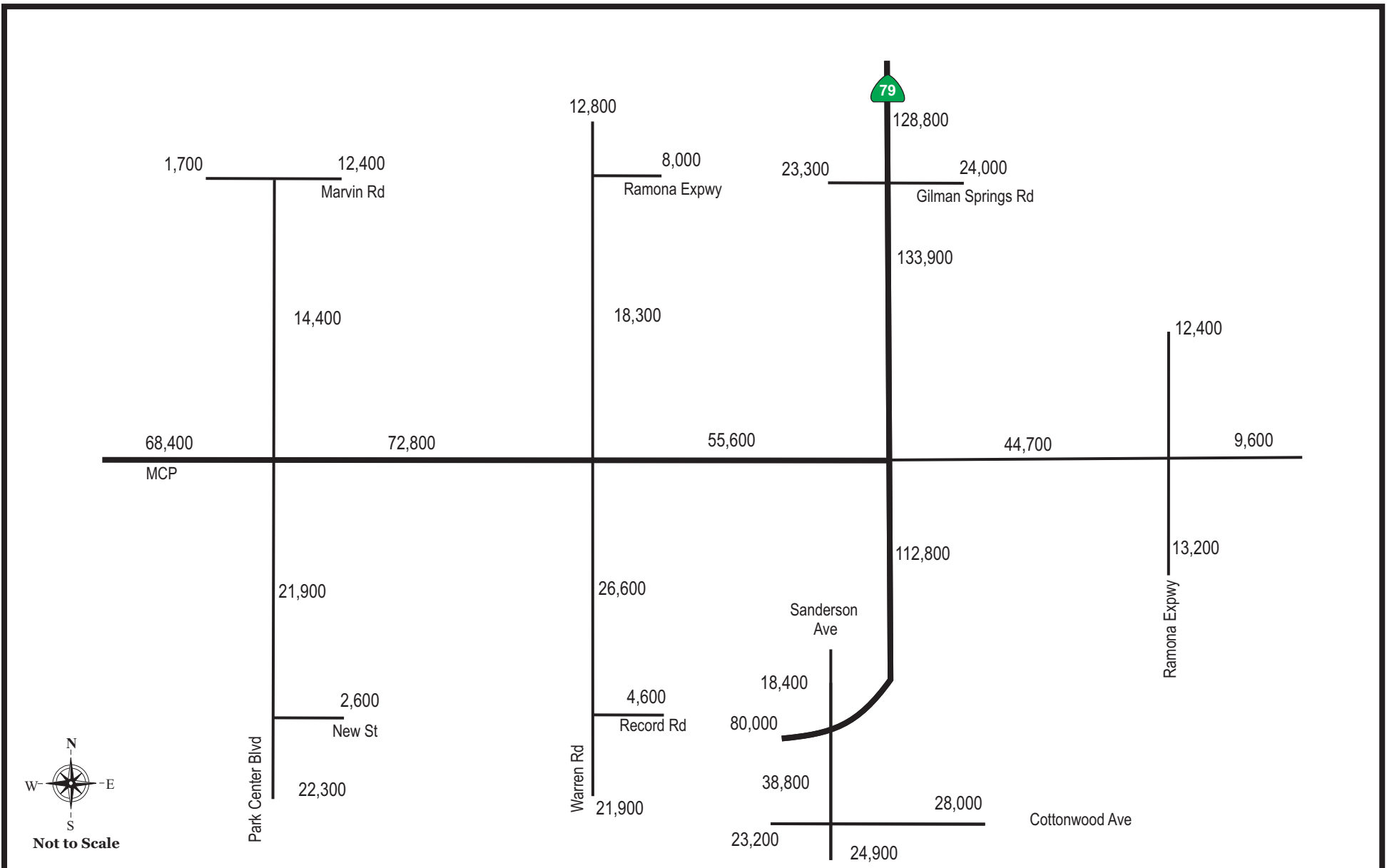

Horizon Year (2040) ADT - Freeway and Street Segments MCP Area - Alternative 5 Modified

Figure 7-30k



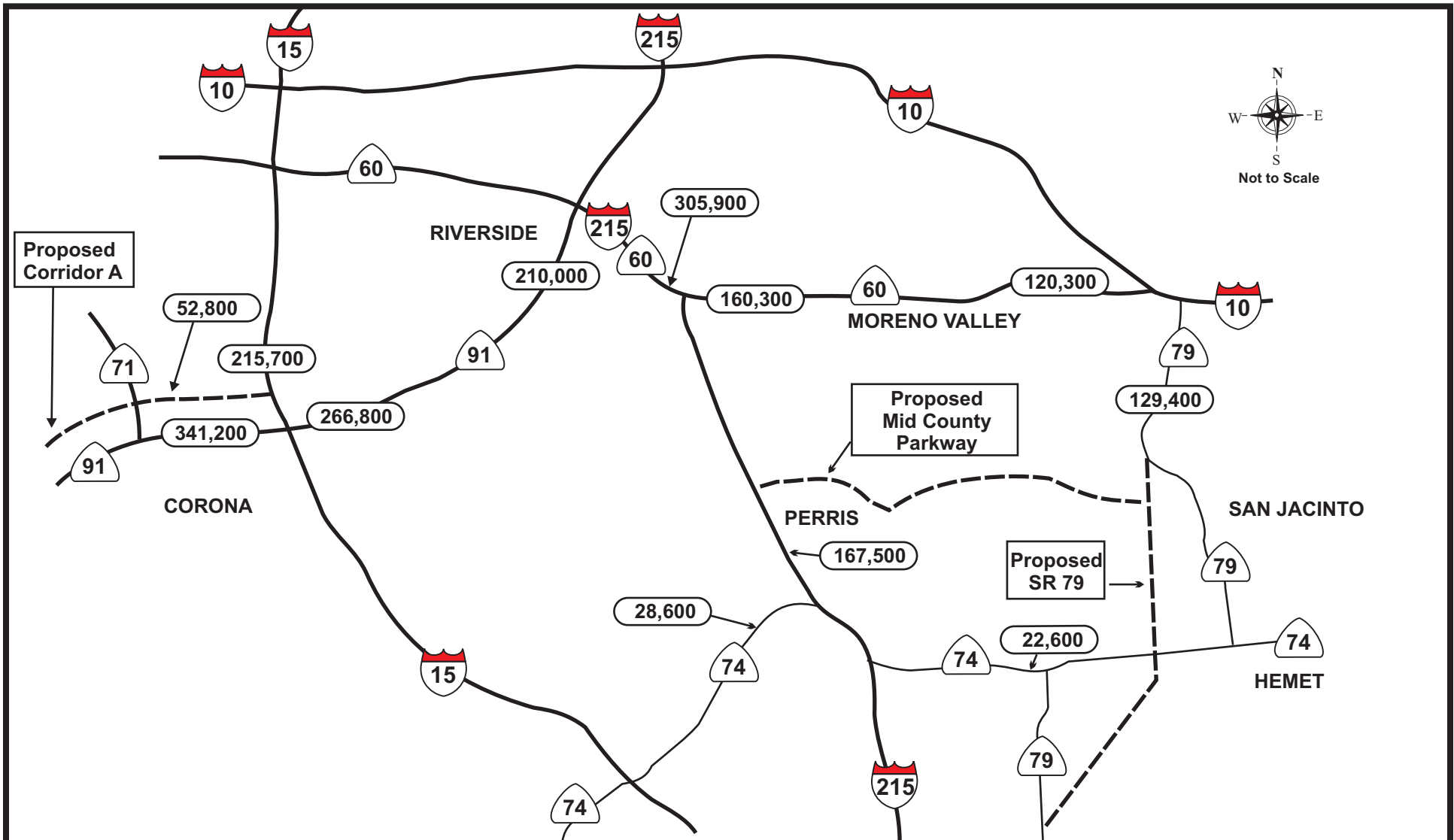

Horizon Year (2040) ADT Freeway and Street Segments Outside MCP Area - Alternative 5 Modified

Figure 7-31

Legend

- Existing Limited Access Roadway
- Existing Arterial Roadway
- - - Proposed Limited Access Roadway
- (XXX,XXX) Average Daily Traffic



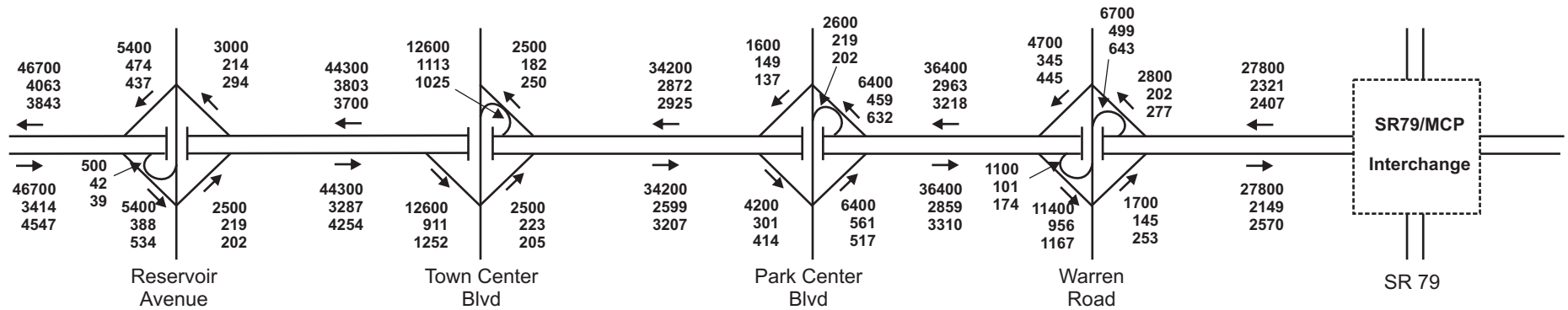
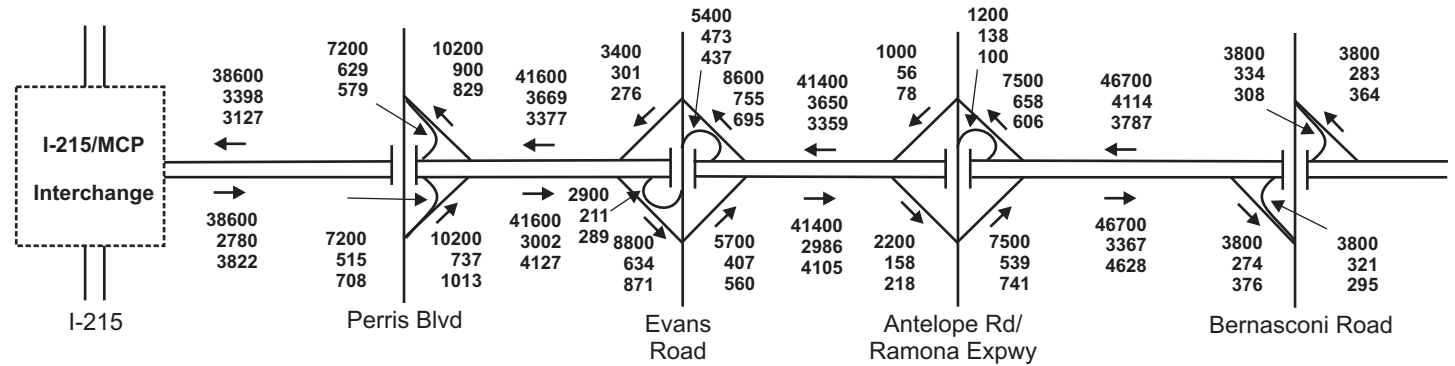

**Horizon Year (2040) Freeway and Ramp Traffic
Mid County Parkway - Alternative 5 Modified**

Figure 7-32

Legend

- XXXXXX Average Daily Traffic
- XXXX AM Peak Hour
- XXXX PM Peak Hour



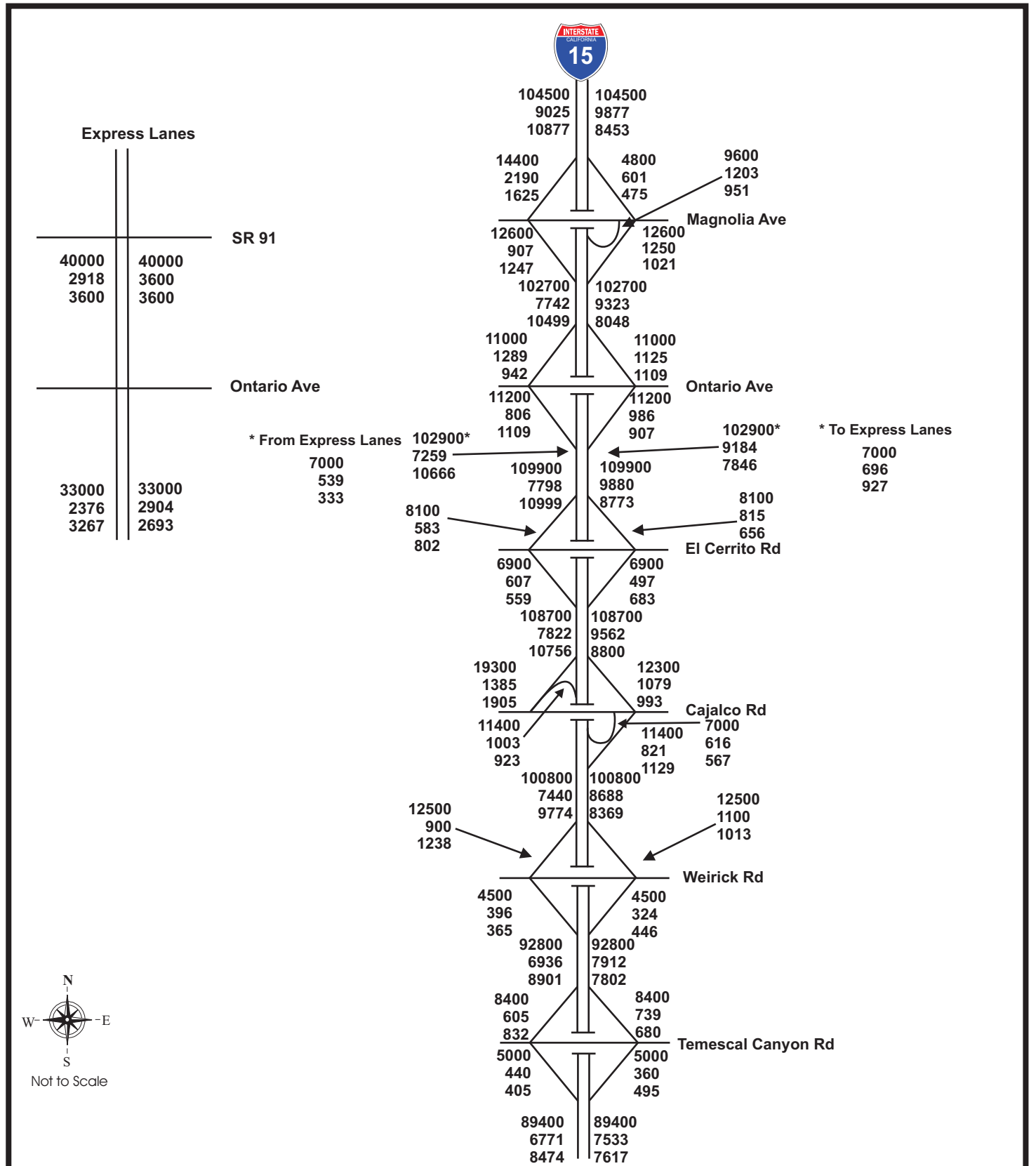

**Horizon Year (2040) Freeway and Ramp Traffic
Interstate 15 - Alternative 5 Modified**

Figure 7-33

Legend

XXXXX ADT
 XXXX AM Peak Hour
 XXXX PM Peak Hour



HOV Lanes

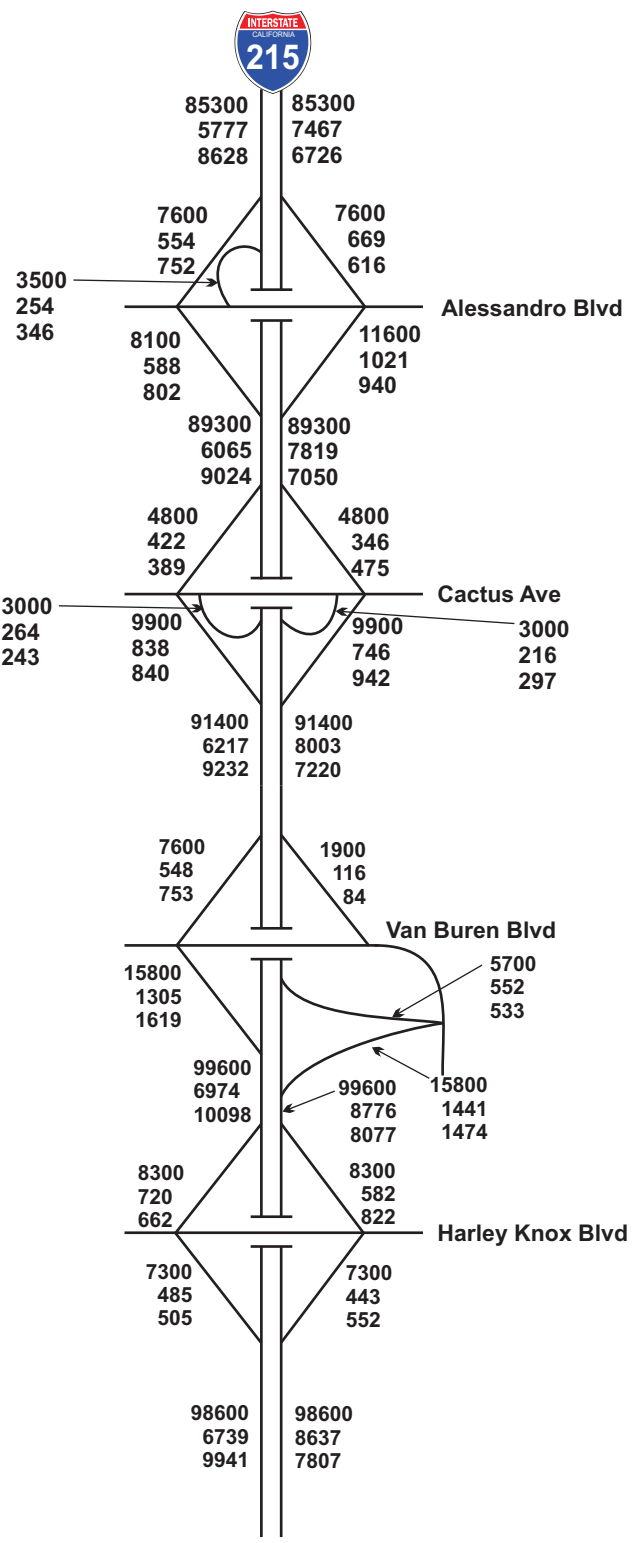
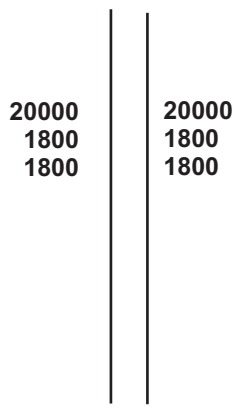

Not to Scale

**Horizon Year (2040)
Freeway and Ramp Traffic
Interstate 215 - Alternative 5 Modified**

Figure 7-34a

Legend

- XXXXX Average Daily Traffic
- XXX AM Peak Hour Traffic
- XXX PM Peak Hour Traffic



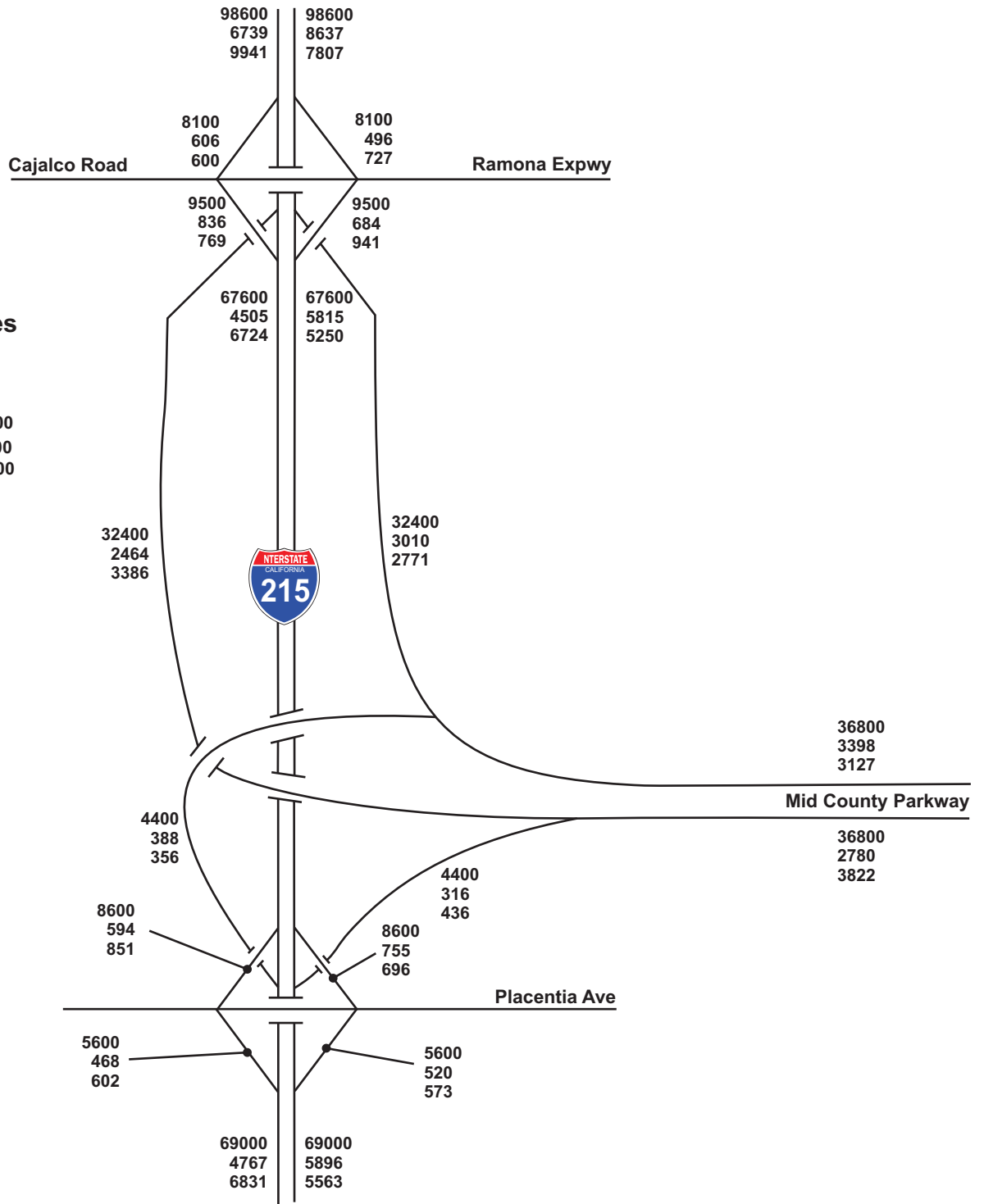

Not to Scale

**Horizon Year (2040)
Freeway and Ramp Traffic
Interstate 215 - Alternative 5 Modified**

Figure 7-34b

Legend

- XXXXX Average Daily Traffic
- XXX AM Peak Hour Traffic
- XXX PM Peak Hour Traffic



**HOV Lanes
(North of Nuevo Road Only)**

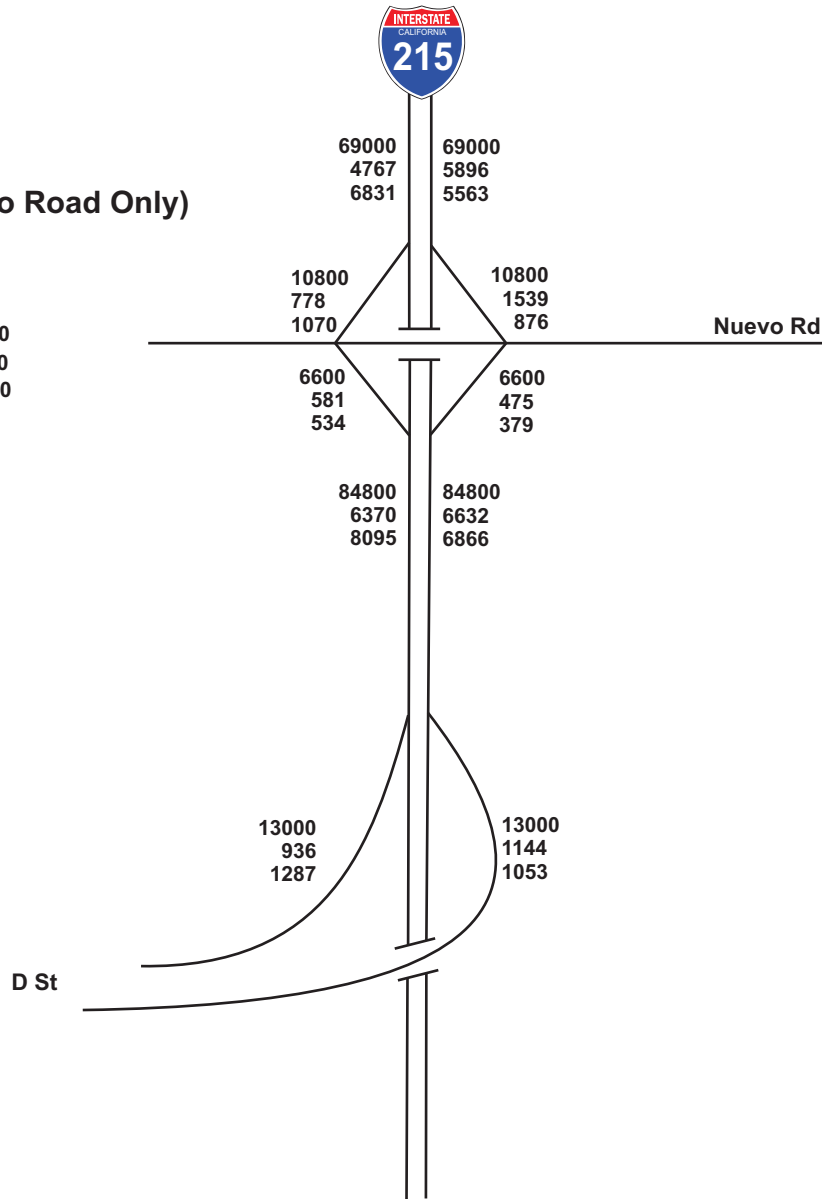
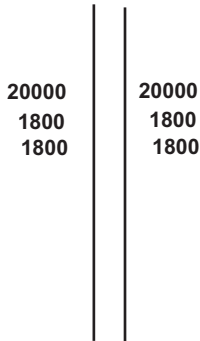

**Horizon Year (2040)
Freeway and Ramp Traffic
Interstate 215 - Alternative 5 Modified**

Figure 7-34c

Legend

- XXXXX Average Daily Traffic
- XXX AM Peak Hour Traffic
- XXX PM Peak Hour Traffic



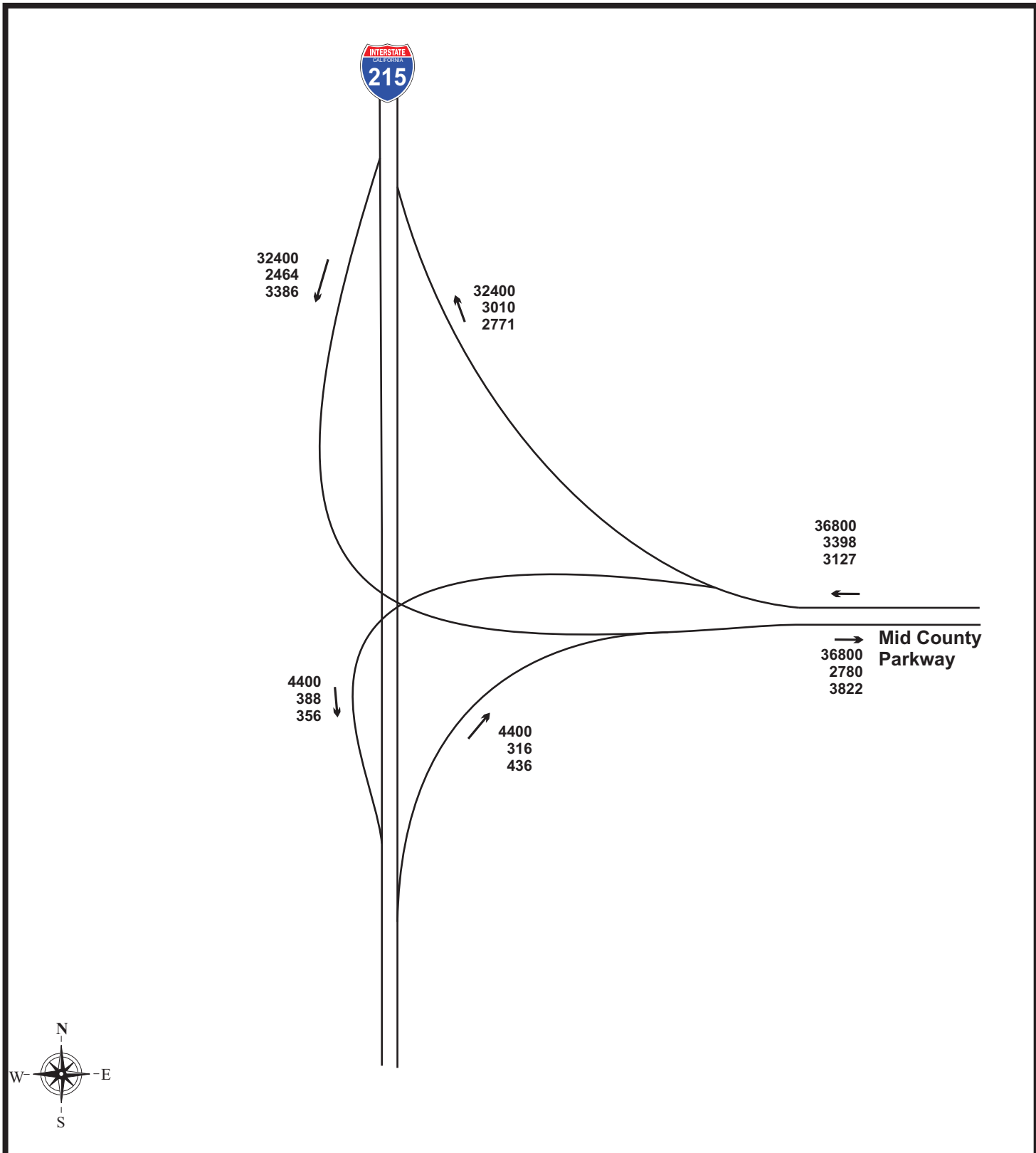

Horizon Year (2040) MCP/I-215 Interchange Area Traffic - Alternative 5 Modified

Figure 7-35

Legend

- XXXXX Average Daily Traffic
- XXXX AM Peak Hour
- XXXX PM Peak Hour



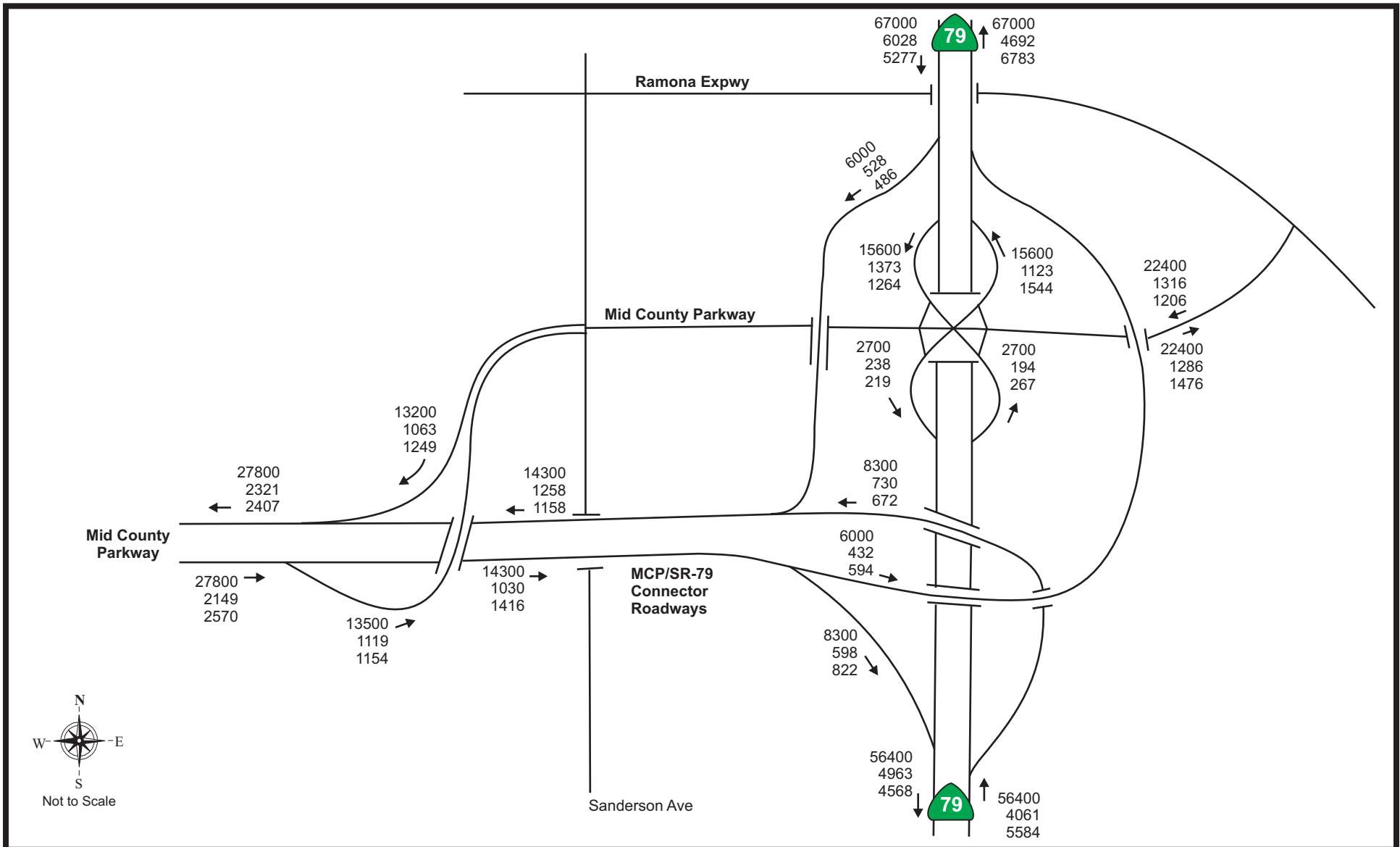

Horizon Year (2040) MCP/SR-79 Interchange Area Traffic - Alternative 5 Modified

Figure 7-36

Legend

- xxxxx Average Daily Traffic
- xxxx AM Peak Hour
- xxxx PM Peak Hour



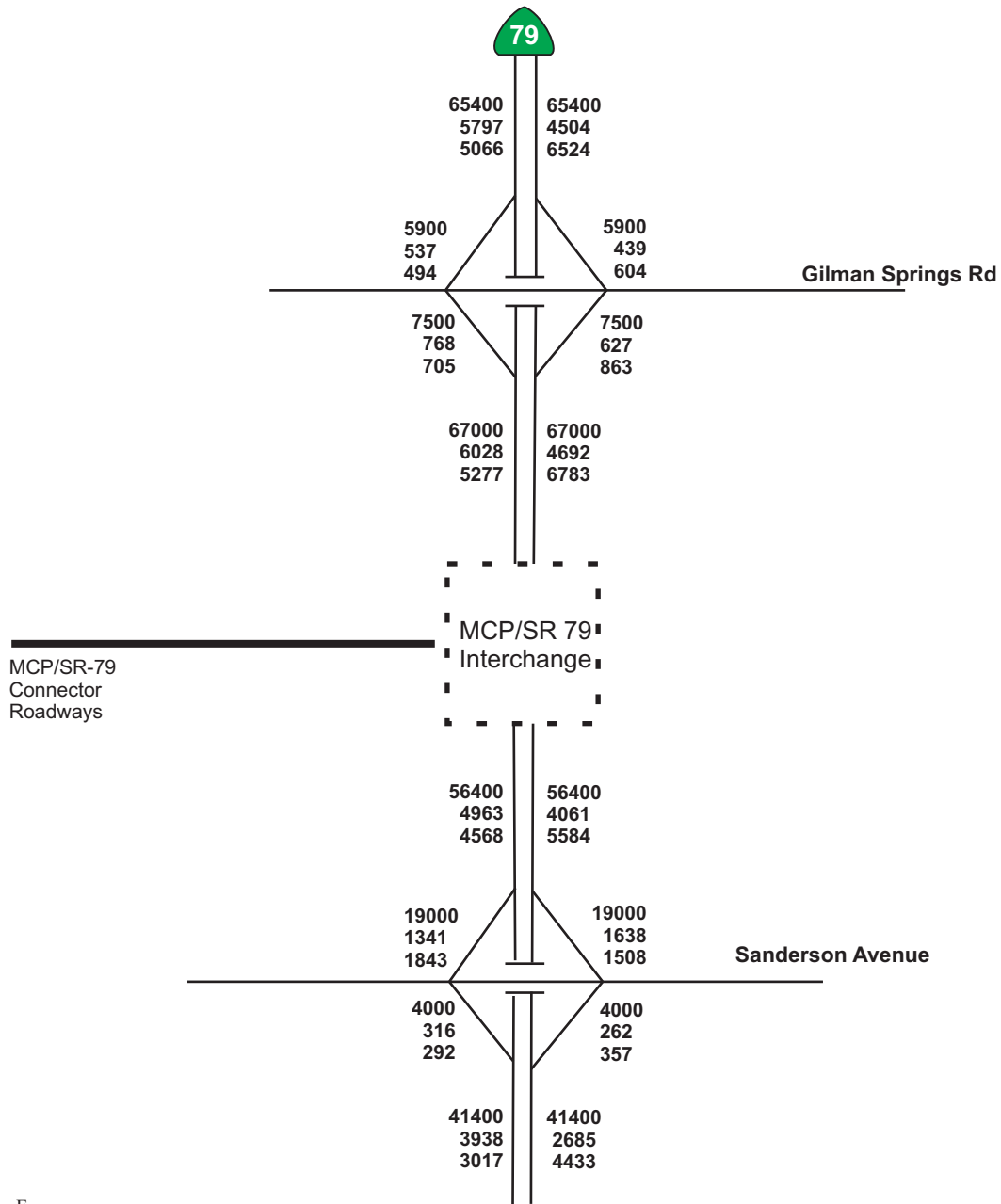

Not to Scale

**Horizon Year (2040)
Freeway and Ramp Traffic
SR 79 - Alternative 5 Modified**

Figure 7-36b

Legend

→ Direction of Travel

X : Number of Lanes (Mixed Flow)



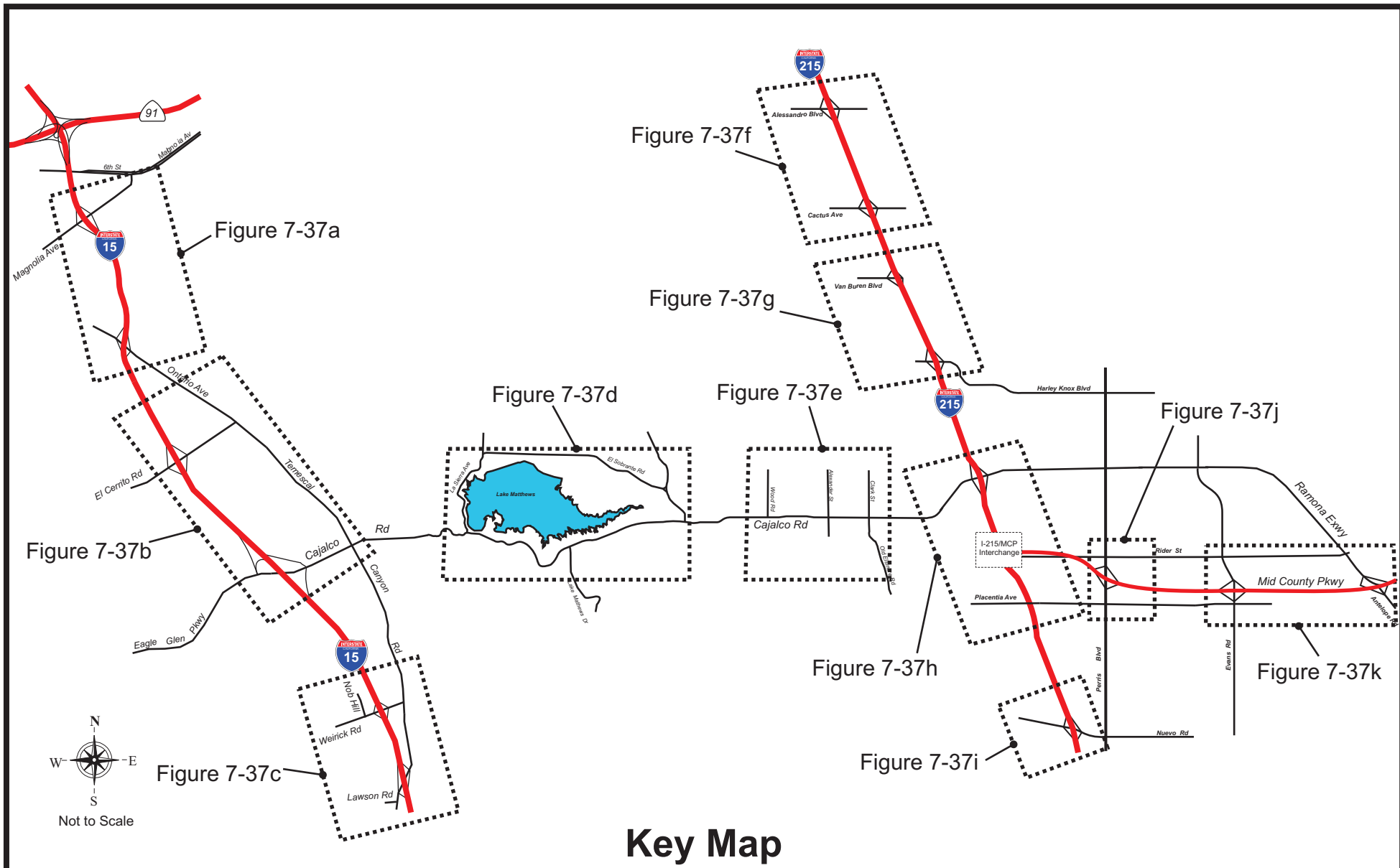

**Horizon Year (2040) AM/PM Peak Hour Traffic - Intersections
Alternative 5 Modified**

Figure 7-37

Legend:

 Figure Areas



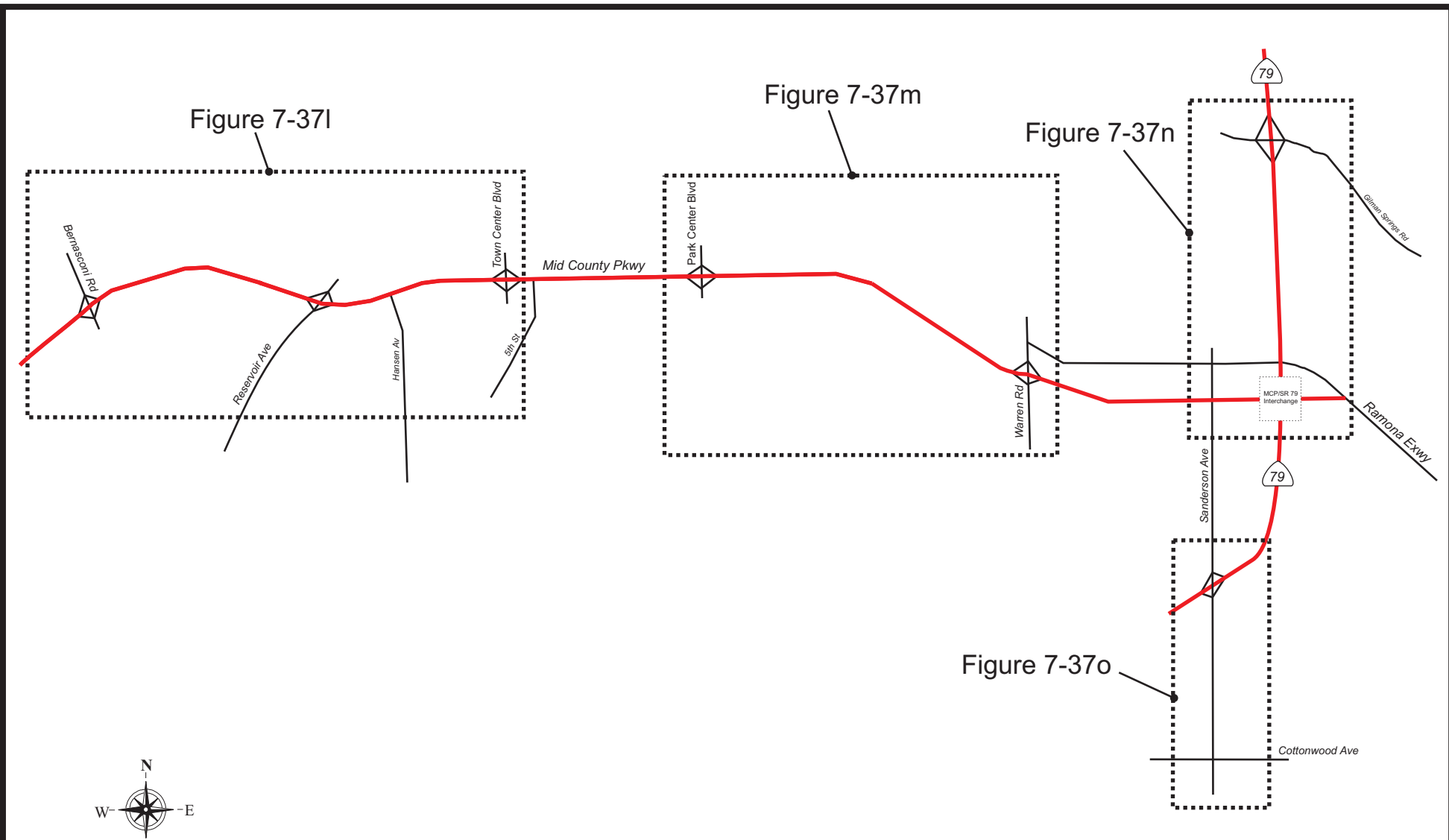

Key Map

**Horizon Year (2040) AM/PM Peak Hour Traffic - Intersections
Alternative 5 Modified**

Figure 7-37 (cont.)

Legend:

 Figure Areas



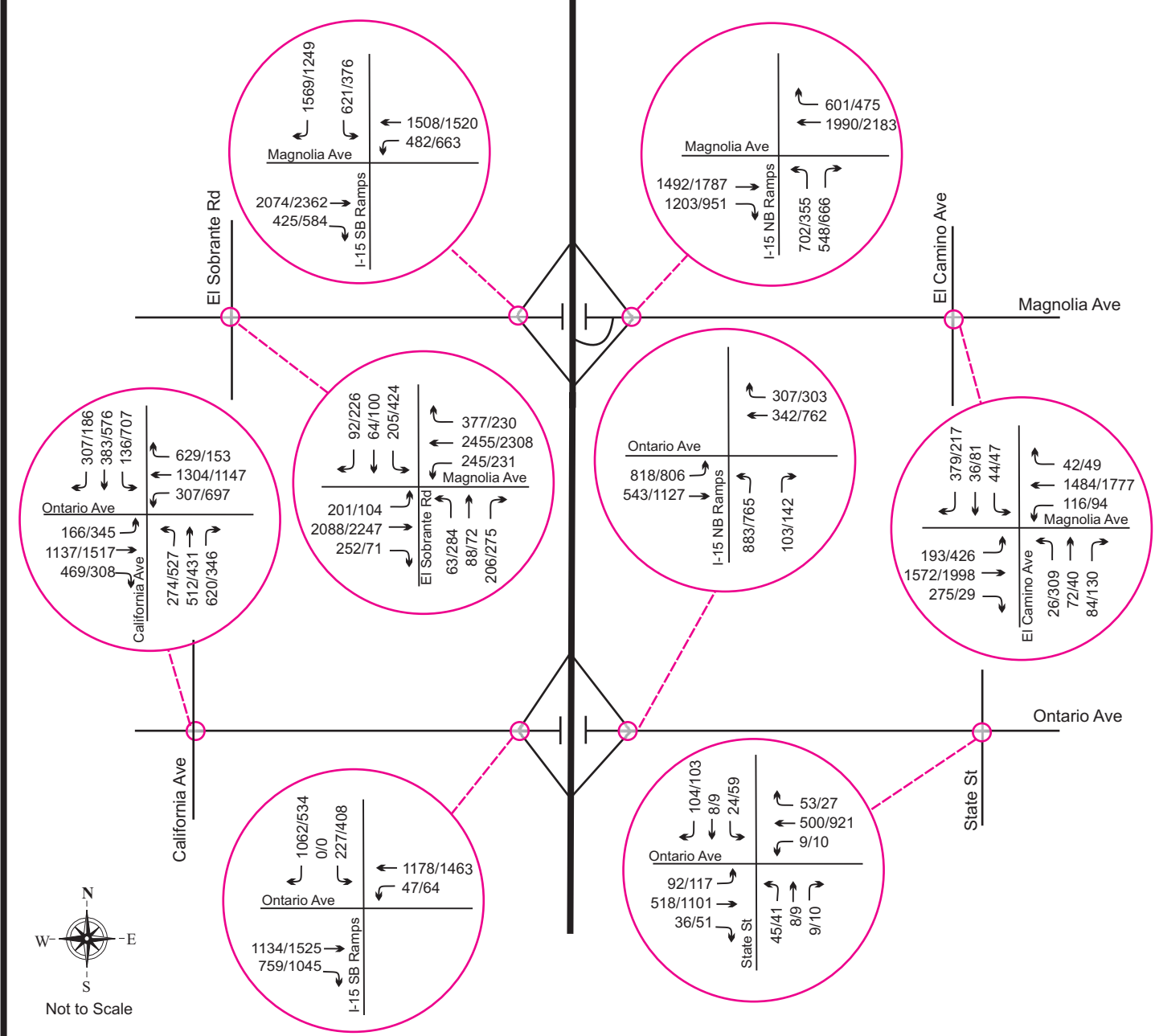

Horizon Year (2040) AM/PM Peak Hour Traffic Intersections - Alternative 5 Modified

Figure 7-37a

XXX/XXX AM/PM Peak Hour



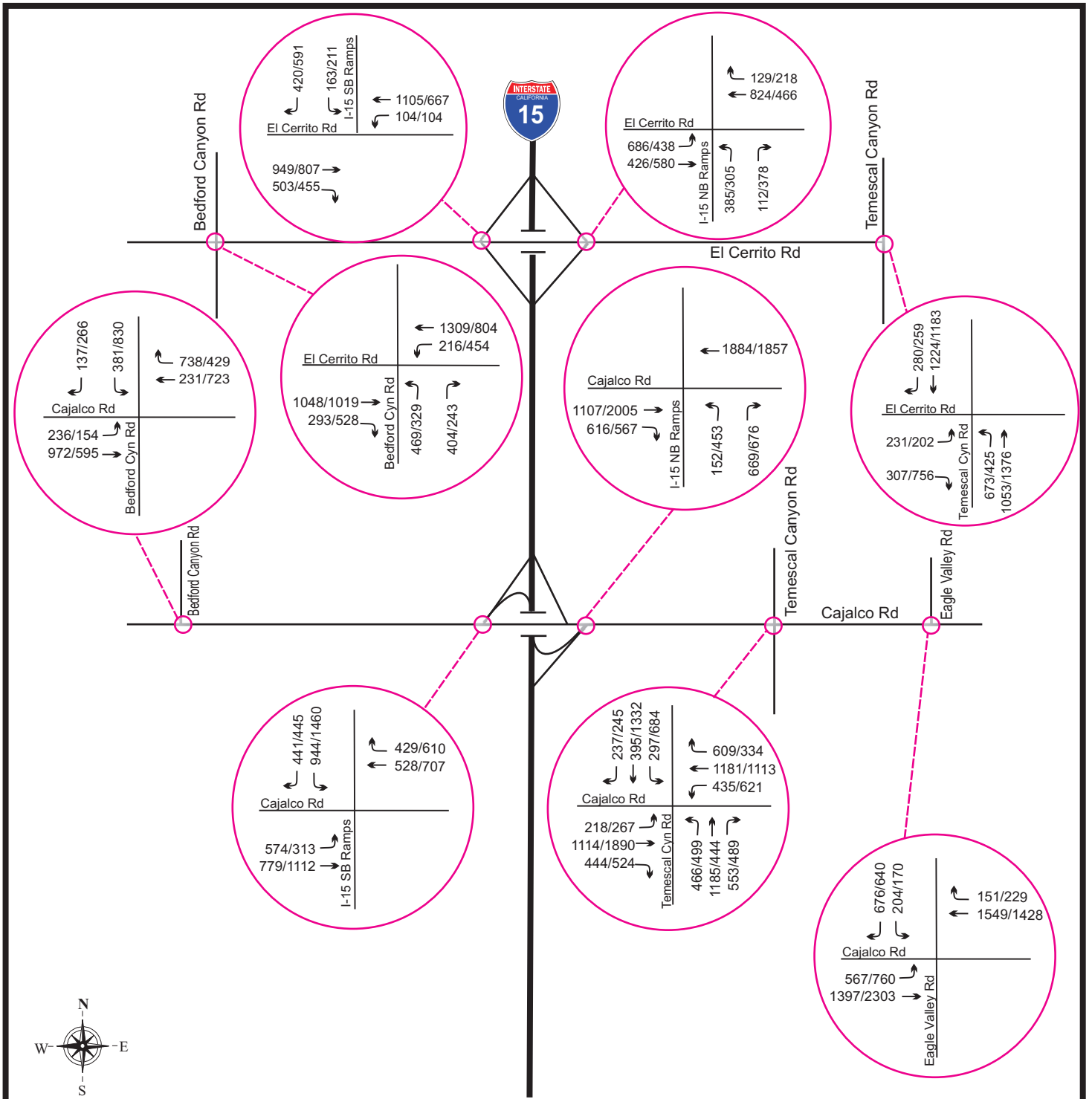

Horizon Year (2040) AM/PM Peak Hour Traffic Intersections - Alternative 5 Modified

Figure 7-37b

XXX/XXX AM/PM Peak Hour



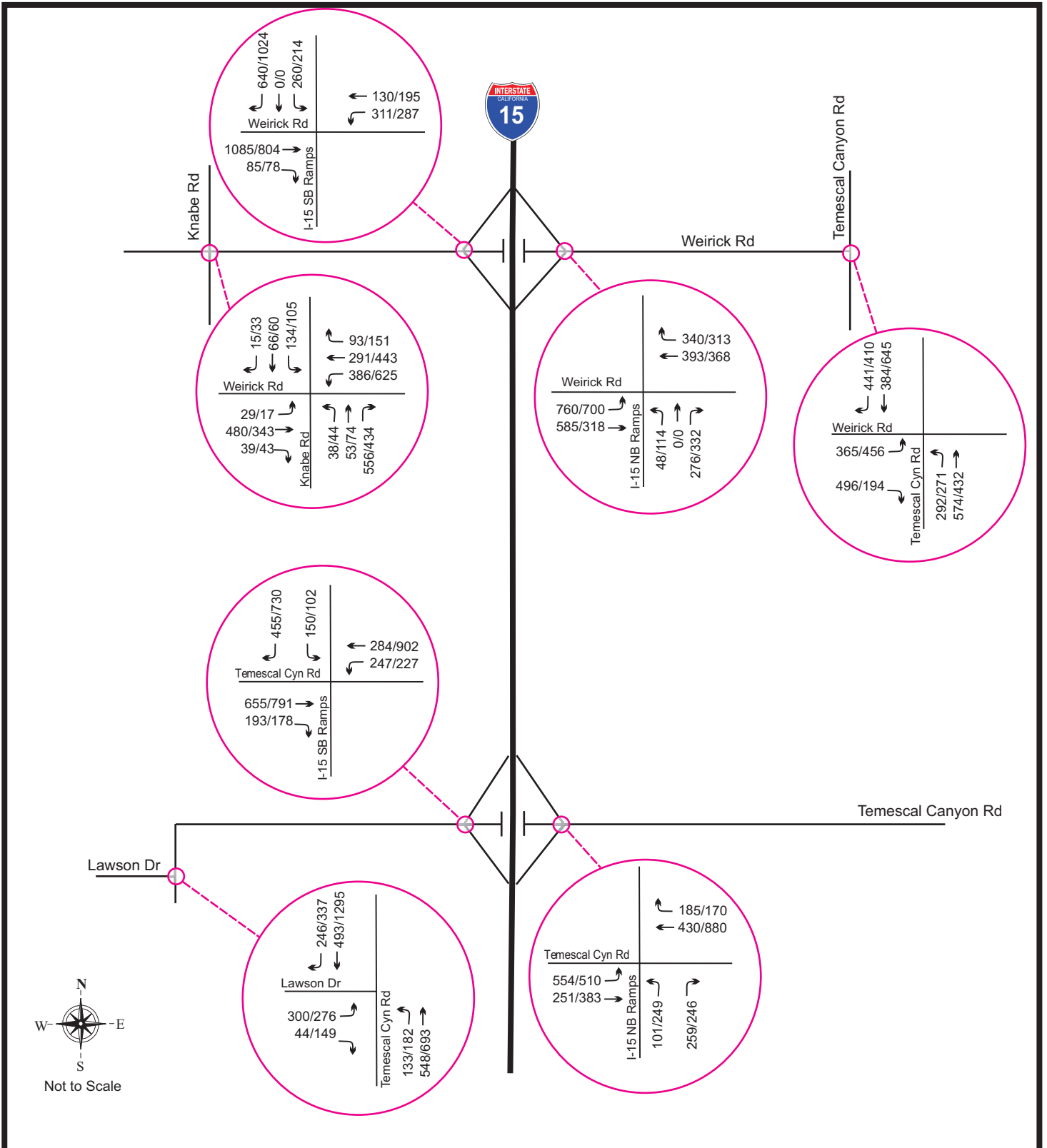

Horizon Year (2040) AM/PM Peak Hour Traffic Intersections - Alternative 5 Modified

Figure 7-37c

XXX/XXX AM/PM Peak Hour



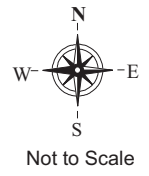
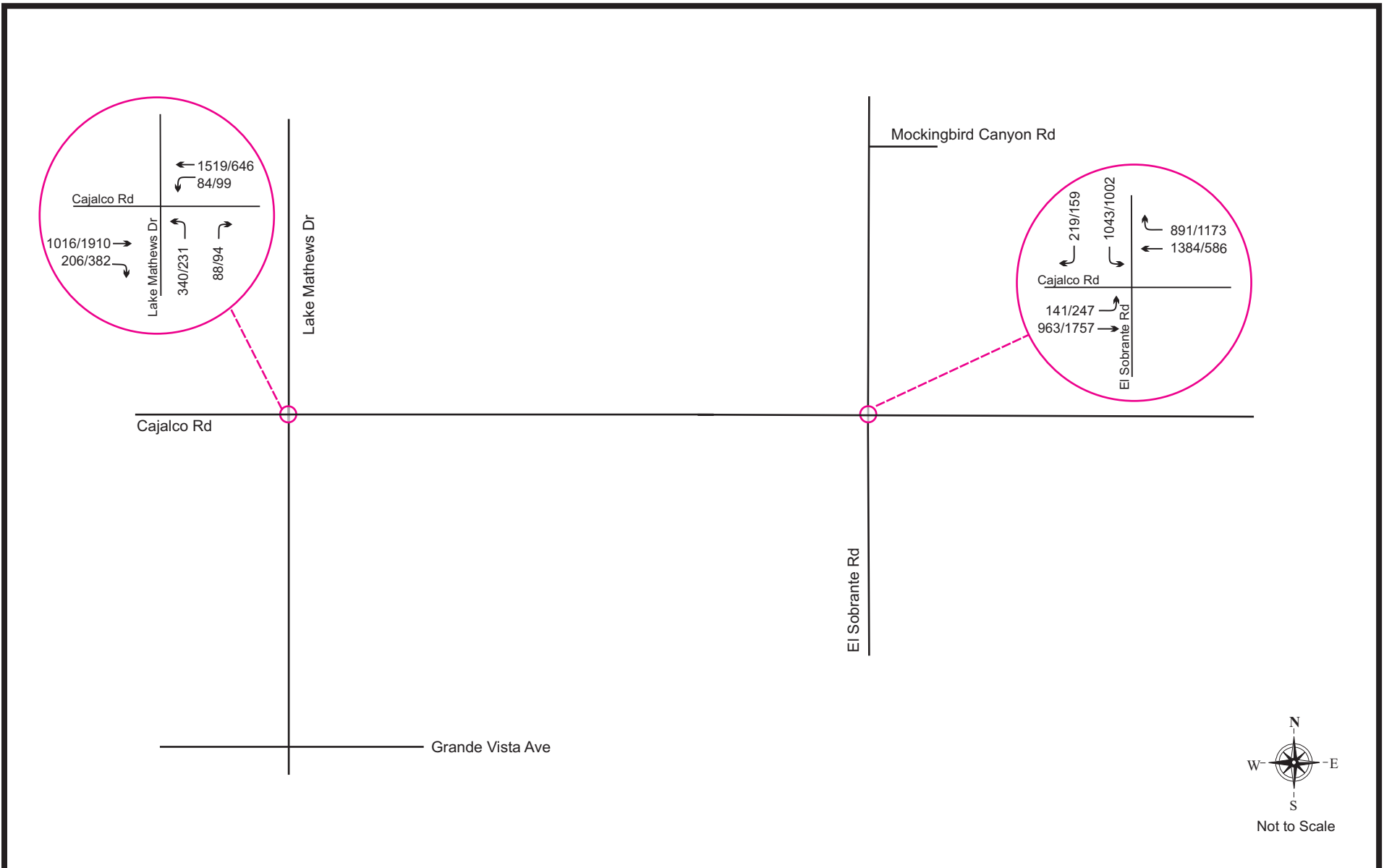

**Horizon Year (2040) AM/PM Peak Hour Traffic Intersections
Alternative 5 Modified**

Figure 7-37d

XXX/XXX AM/PM Peak Hour



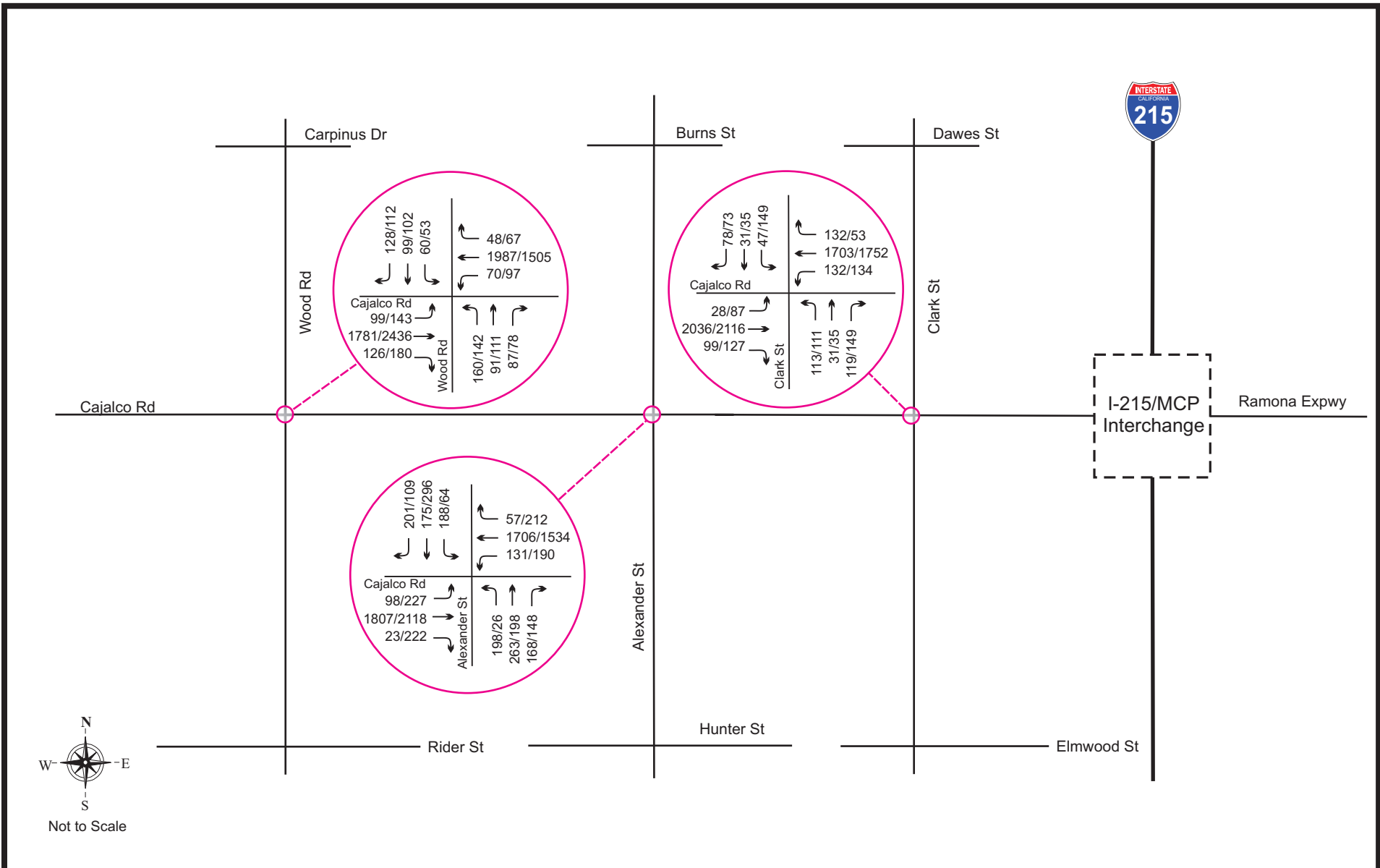

**Horizon Year (2040) AM/PM Peak Hour Traffic Intersections
Alternative 5 Modified**

Figure 7-37e

XXX/XXX AM/PM Peak Hour



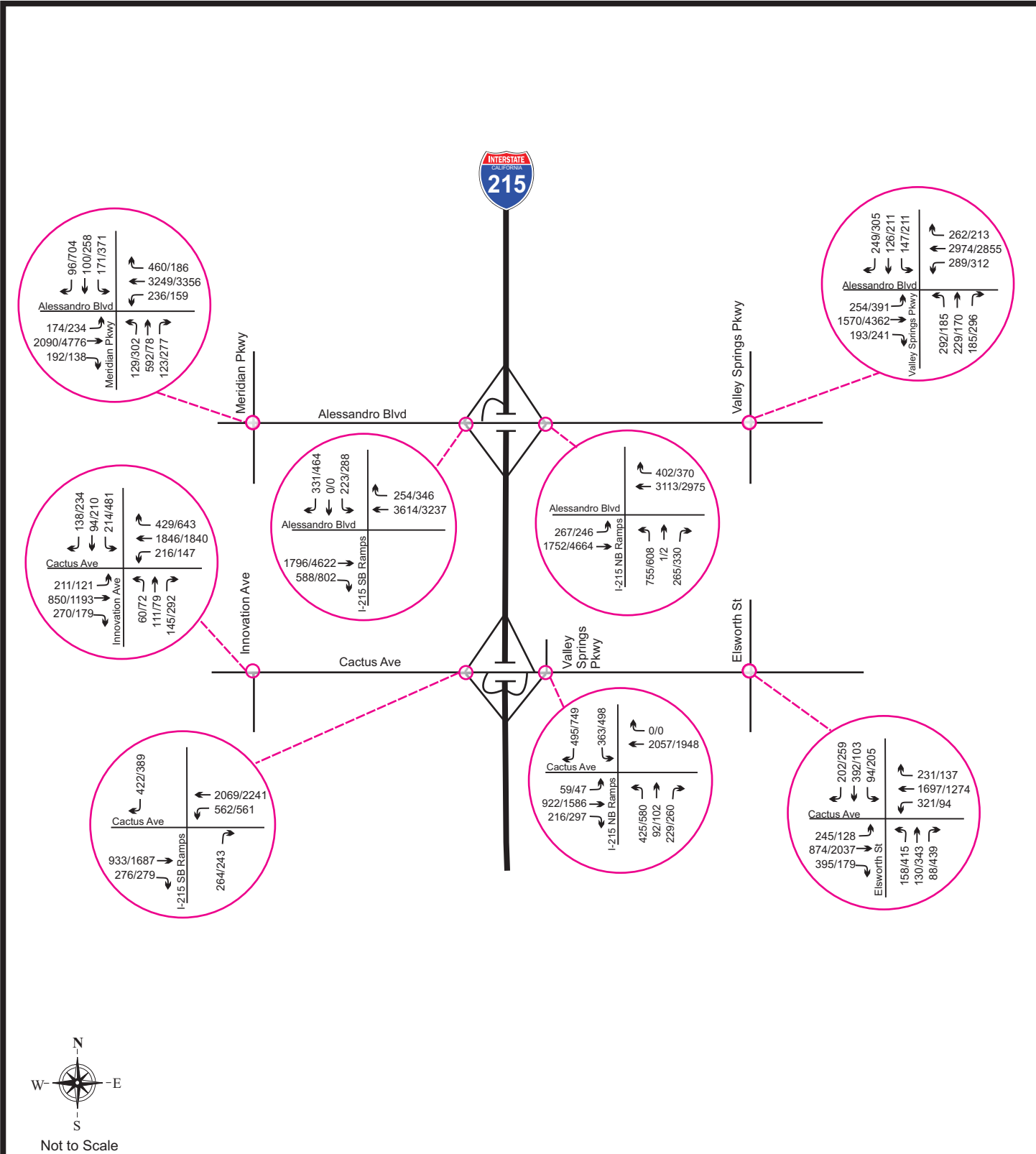

Horizon Year (2040) AM/PM Peak Hour Traffic Intersections - Alternative 5 Modified

Figure 7-37f

XXX/XXX AM/PM Peak Hour



VRPA TECHNOLOGIES, INC.

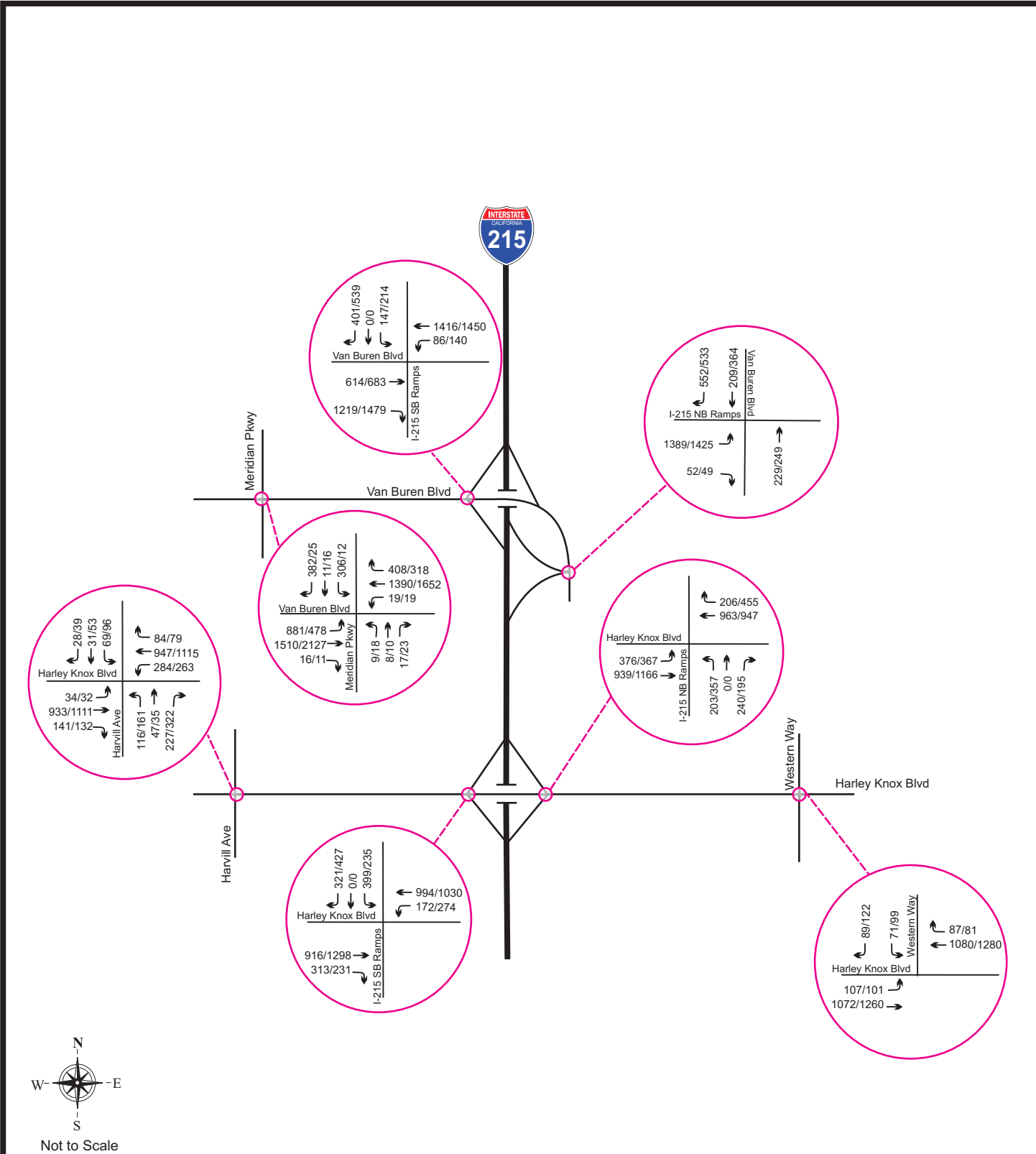

Horizon Year (2040) AM/PM Peak Hour Traffic Intersections - Alternative 5 Modified

Figure 7-37g

XXX/XXX AM/PM Peak Hour



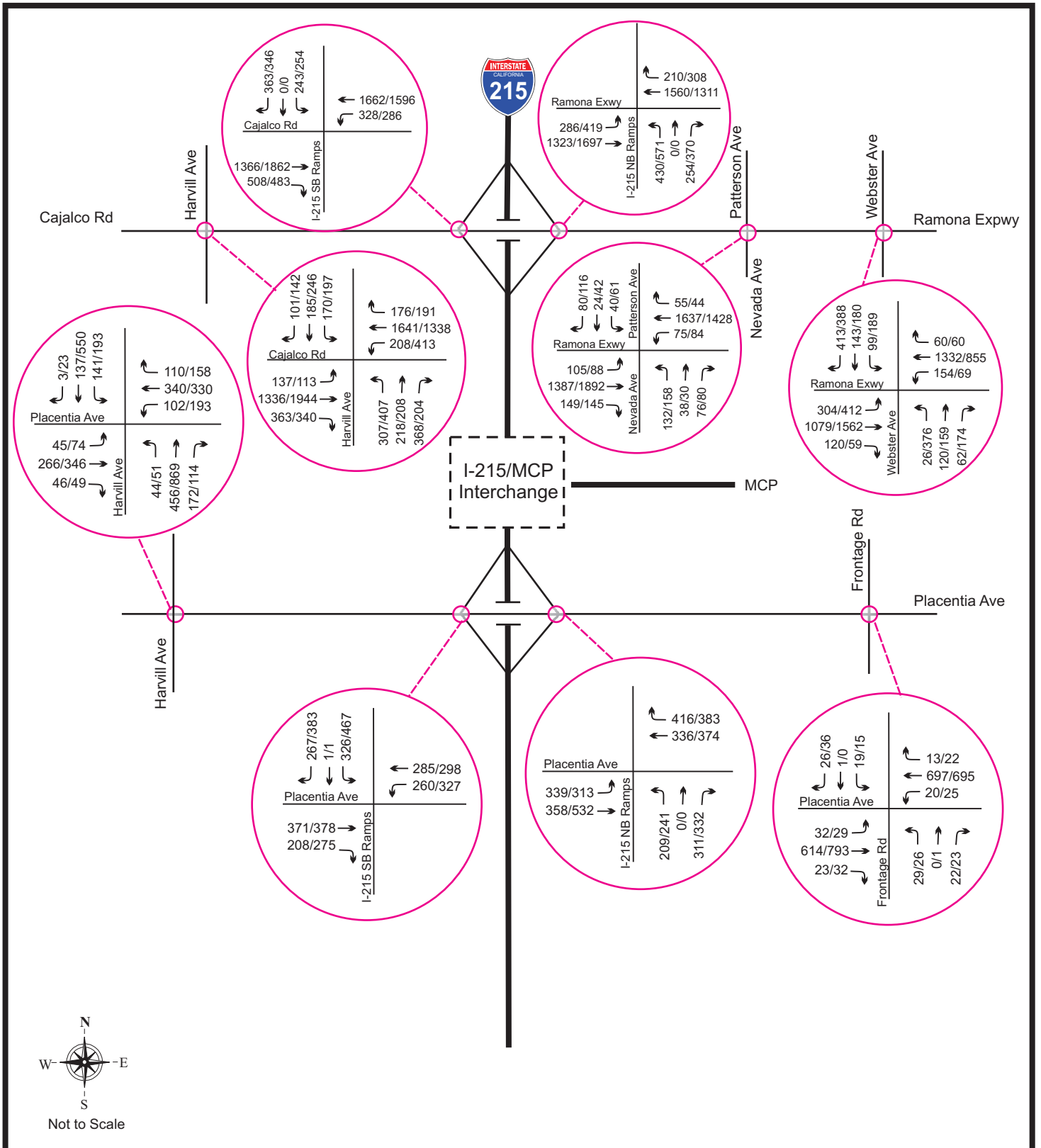

Horizon Year (2040) AM/PM Peak Hour Traffic Intersections - Alternative 5 Modified

Figure 7-37h

XXX/XXX AM/PM Peak Hour



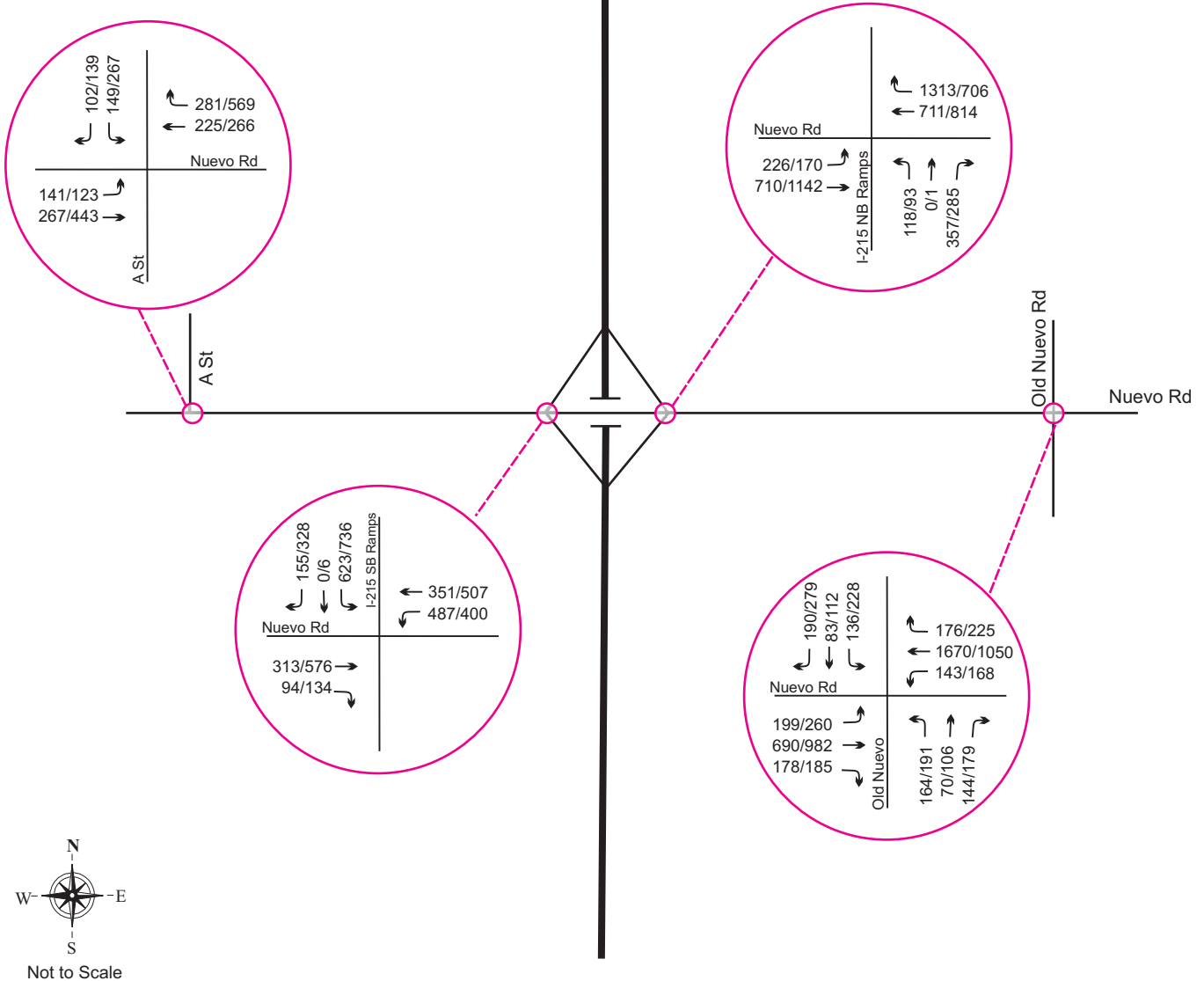

Horizon Year (2040) AM/PM Peak Hour Traffic Intersections - Alternative 5 Modified

Figure 7-37i

XXX/XXX AM/PM Peak Hour



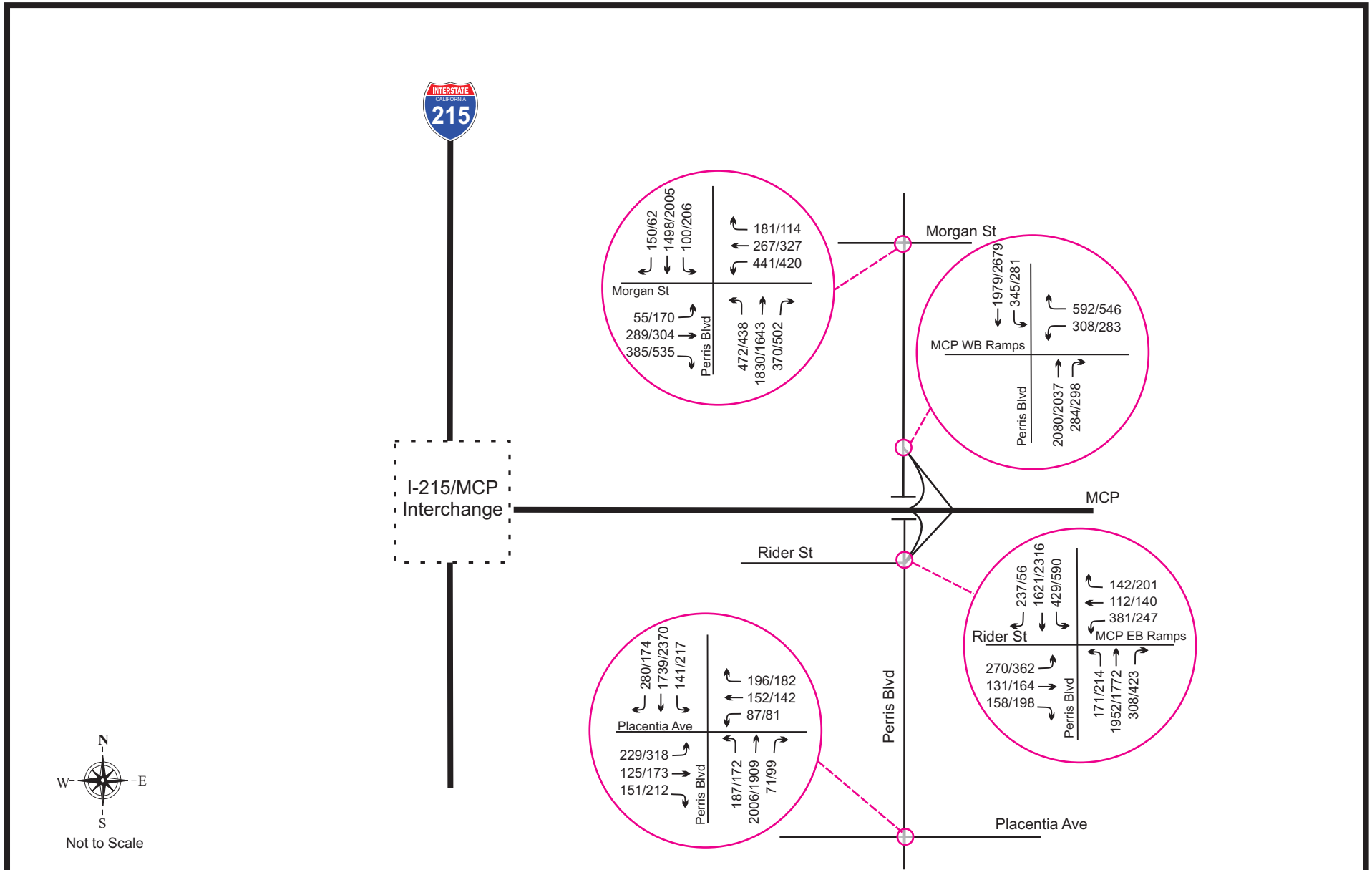

**Horizon Year (2040) AM/PM Peak Hour Traffic Intersections
Alternative 5 Modified**

Figure 7-37j

XXX/XXX AM/PM Peak Hour



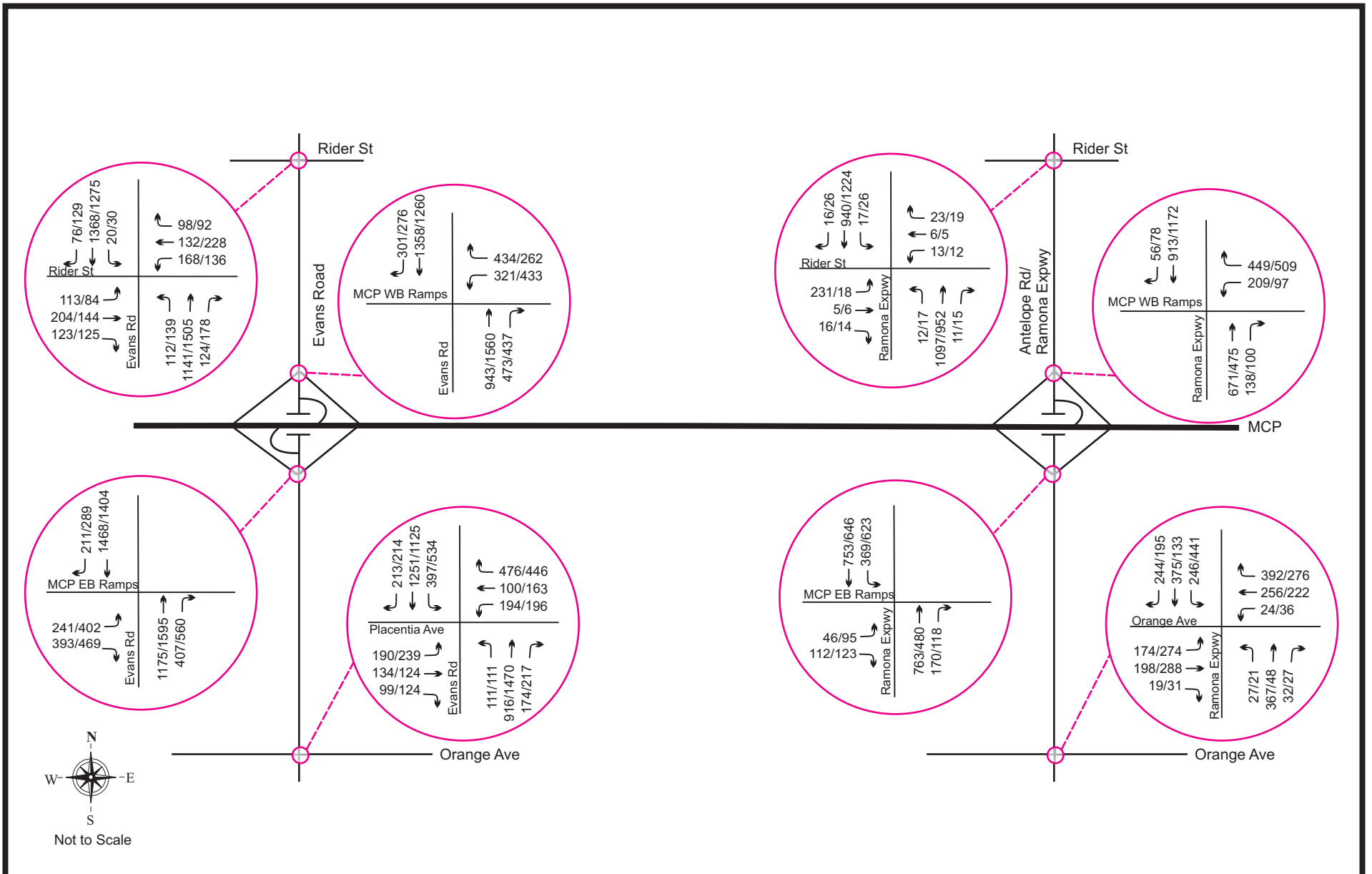

**Horizon Year (2040) AM/PM Peak Hour Traffic Intersections
Alternative 5 Modified**

Figure 7-37k

XXX/XXX AM/PM Peak Hour



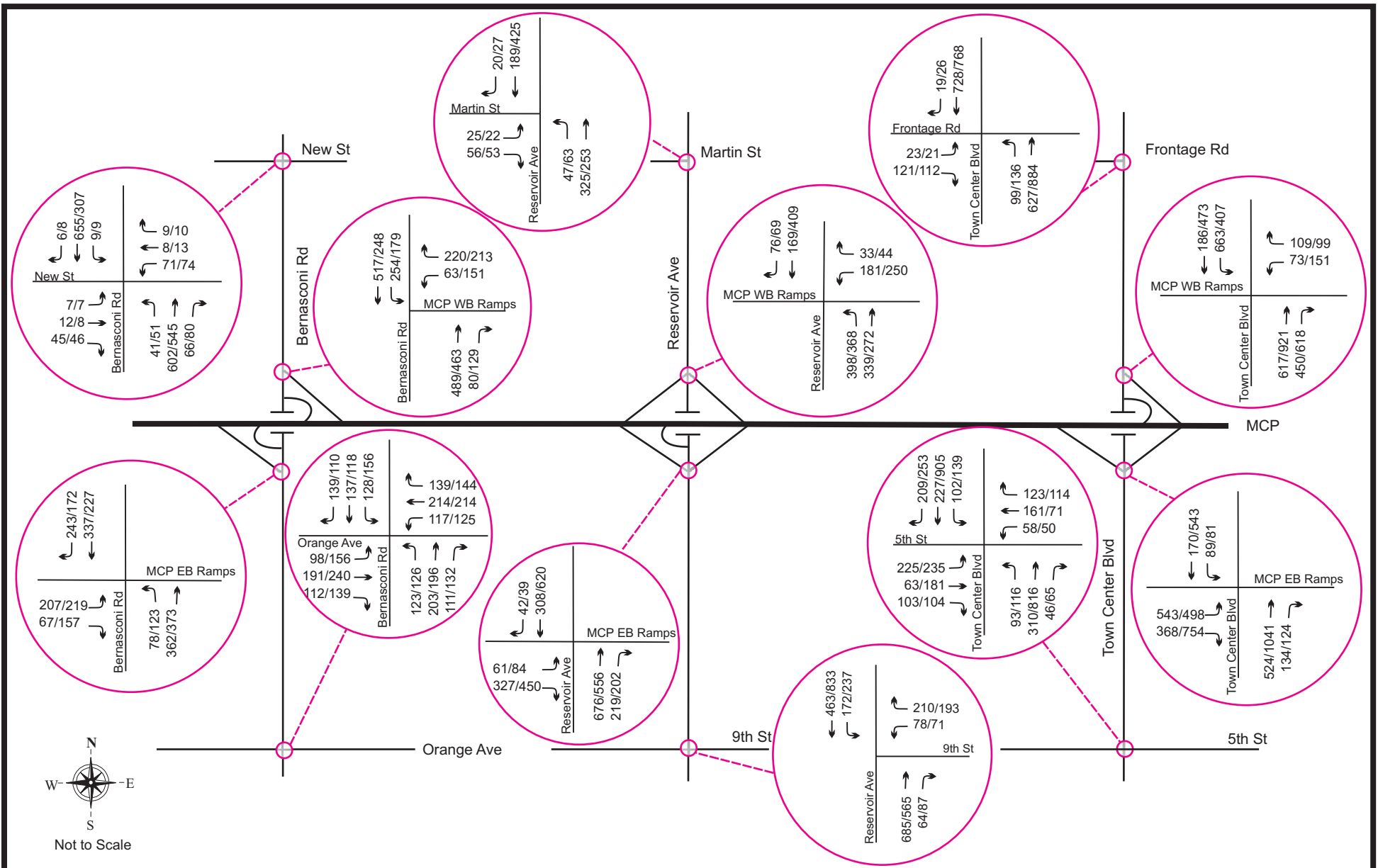

**Horizon Year (2040) AM/PM Peak Hour Traffic Intersections
Alternative 5 Modified**

Figure 7-371

XXX/XXX AM/PM Peak Hour



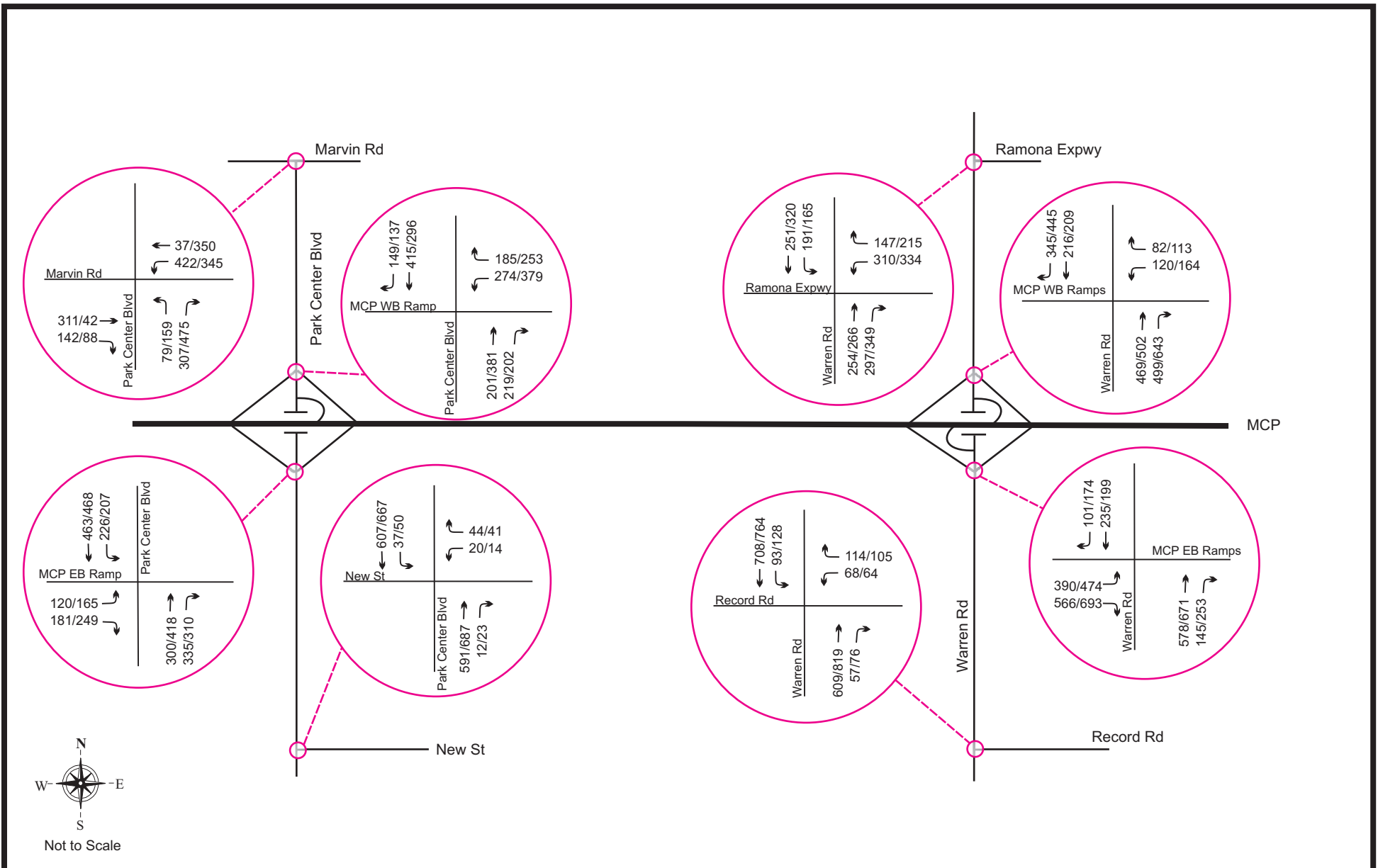

**Horizon Year (2040) AM/PM Peak Hour Traffic Intersections
Alternative 5 Modified**

Figure 7-37m

XXX/XXX AM/PM Peak Hour



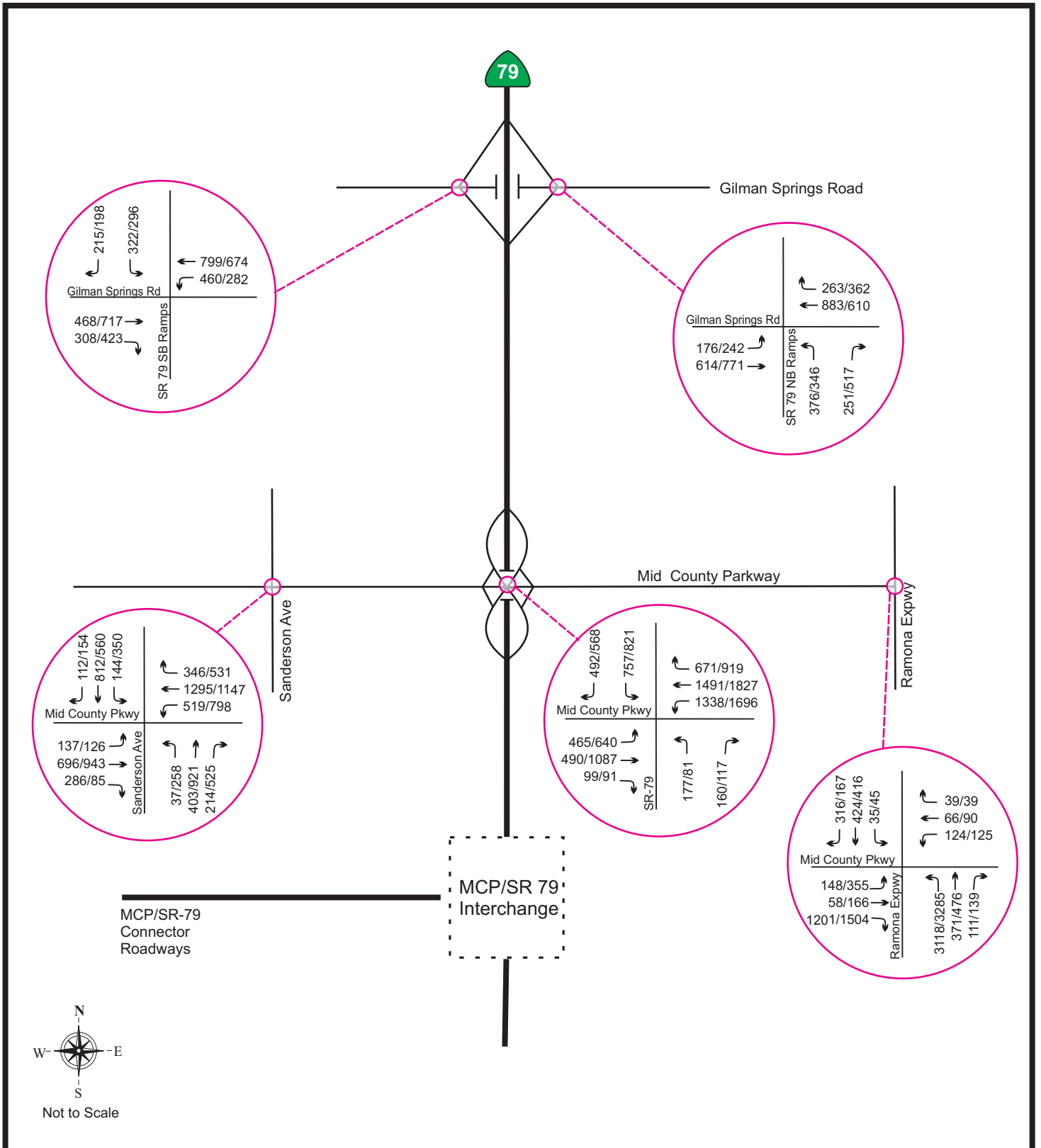

Horizon Year (2040) AM/PM Peak Hour Traffic Intersections - Alternative 5 Modified

Figure 7-37n

XXX/XXX AM/PM Peak Hour



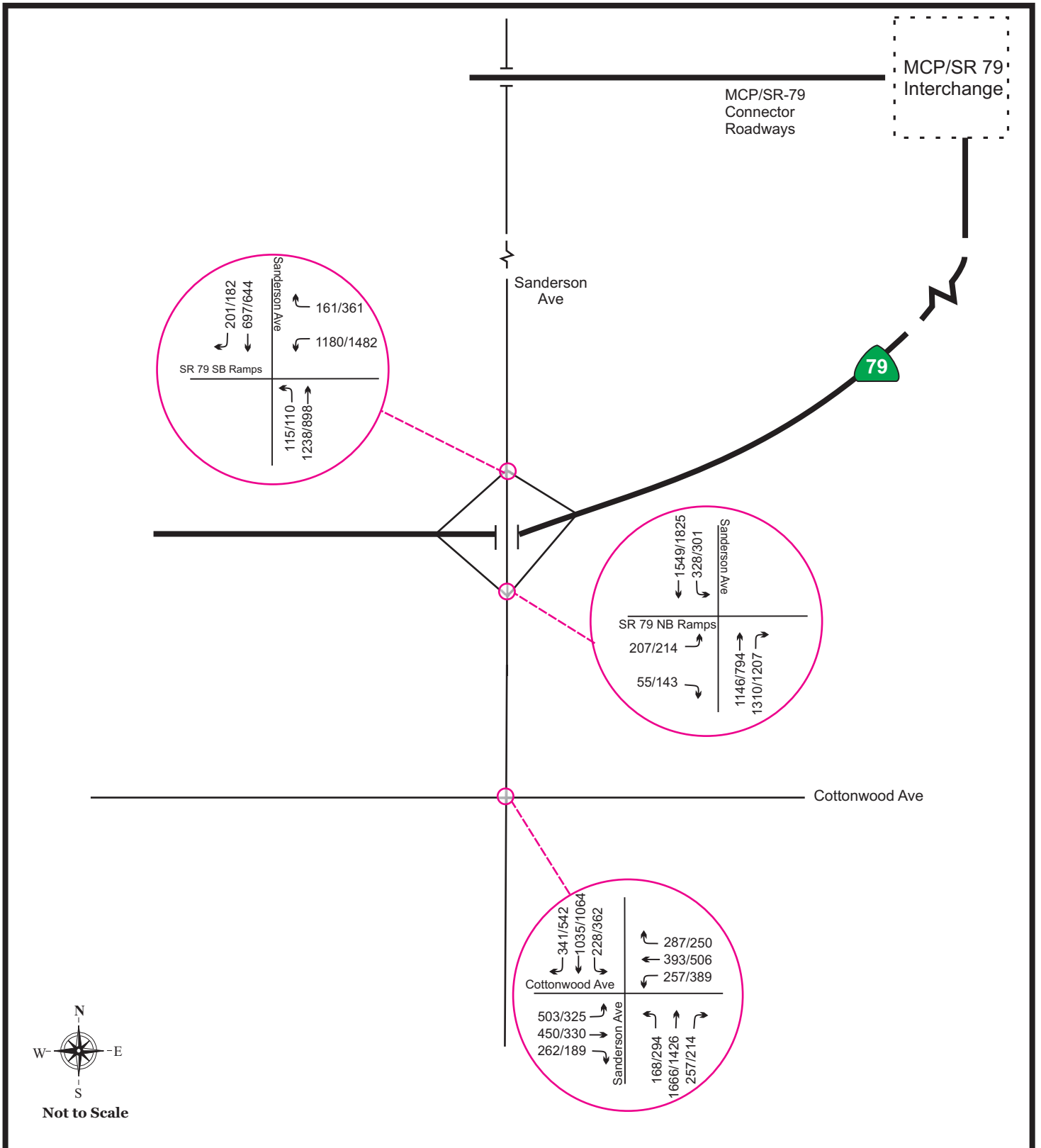

Horizon Year (2040) AM/PM Peak Hour Traffic Intersections - Alternative 5 Modified

Figure 7-37o

XXX/XXX AM/PM Peak Hour



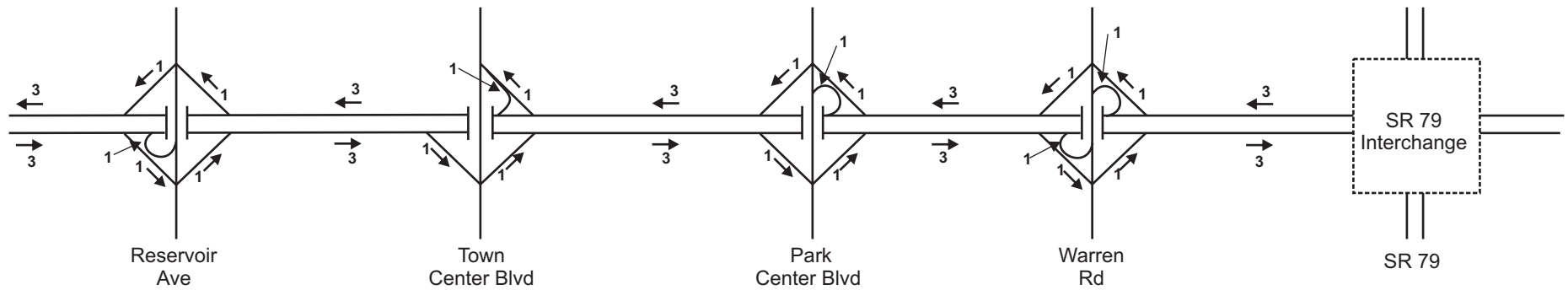
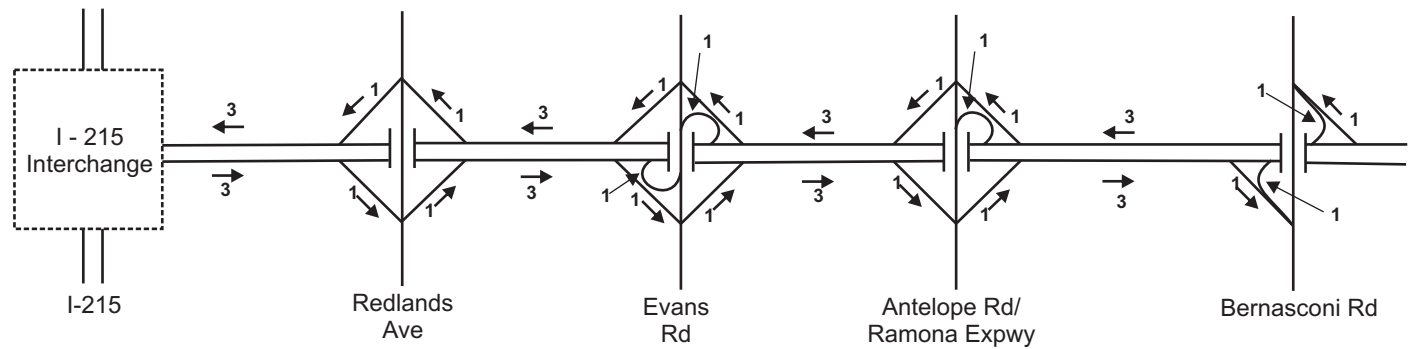

**Horizon Year (2040) Freeway Mainline Lane Geometry
Mid County Parkway - Alternative 9 Modified**

Figure 7-38

Legend

←^x Number of Lanes



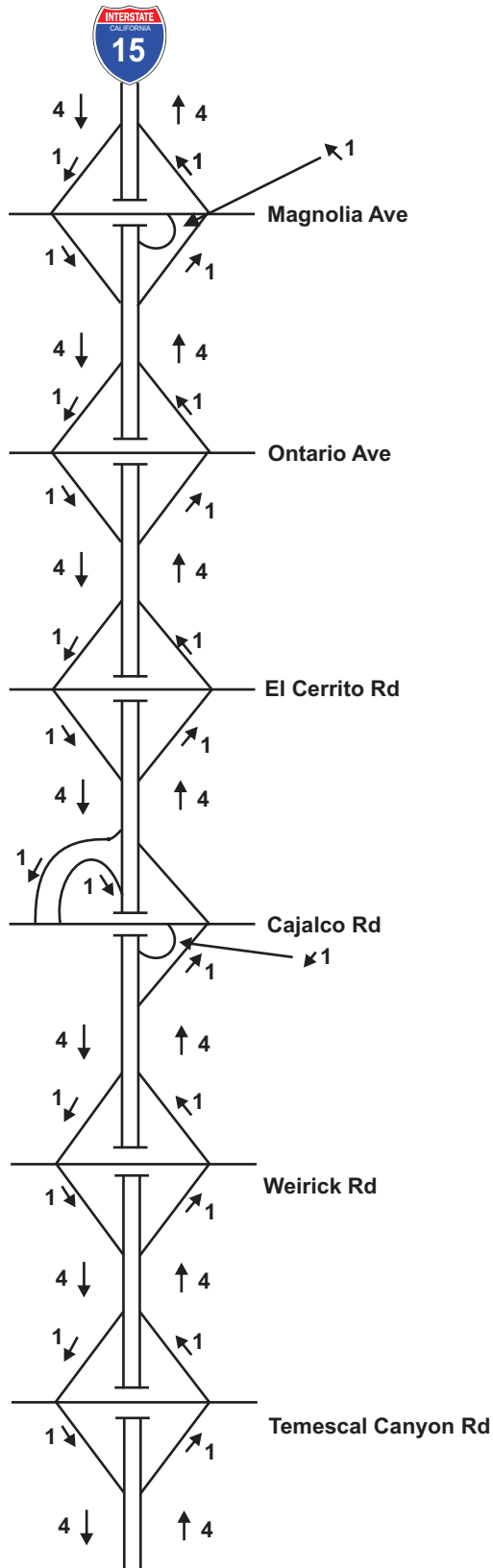

Note:
Two Express Lanes in each direction of travel will be provided in addition to the lanes indicated on I-15.

**Horizon Year (2040) Freeway Mainline Lane Geometry
Interstate 15 - Alternative 9 Modified**

Figure 7-39

Legend

- Direction of Travel
- X : Number of Lanes (Mixed Flow)



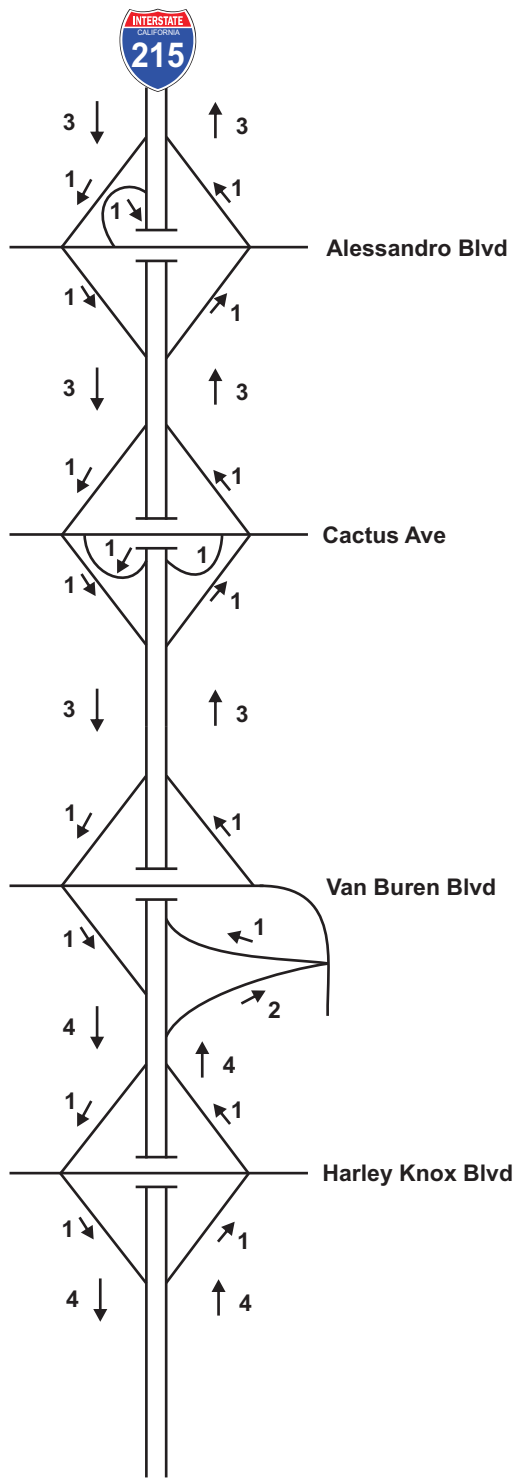

Note:
 One HOV Lane in each direction of travel will be provided in addition to the lanes indicated on I-215.

**Horizon Year (2040)
 Freeway Mainline Lane Geometry
 Interstate 215 - Alternative 9 Modified**

Figure 7-40a

Legend
 → Direction of Travel
 X : Number of Lanes (Mixed Flow)



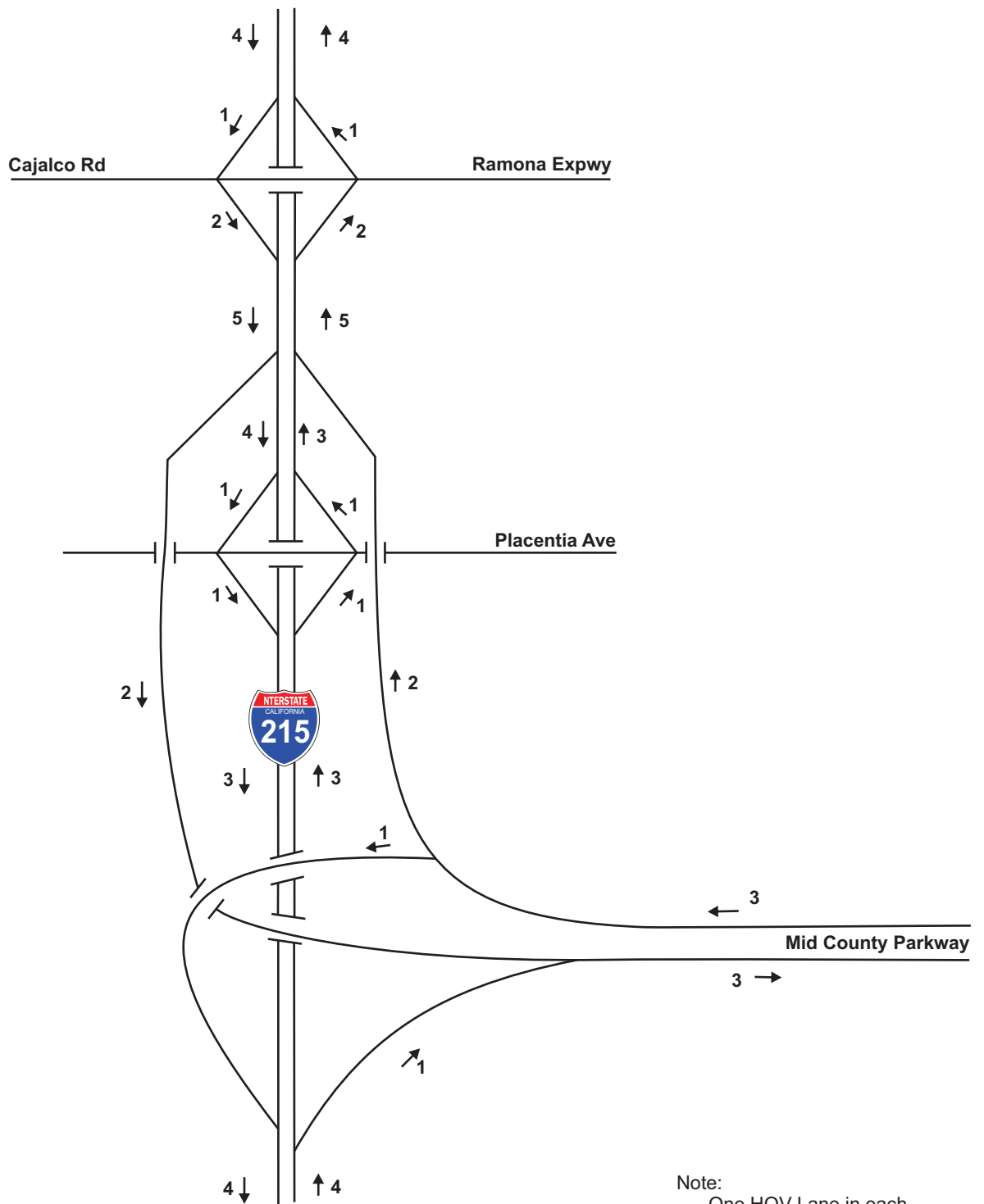

Note:
 One HOV Lane in each direction of travel will be provided in addition to the lanes indicated on I-215.

**Horizon Year (2040)
 Freeway Mainline Lane Geometry
 Interstate 215 - Alternative 9 Modified**

Figure 7-40b

Legend
 → Direction of Travel
 X : Number of Lanes (Mixed Flow)



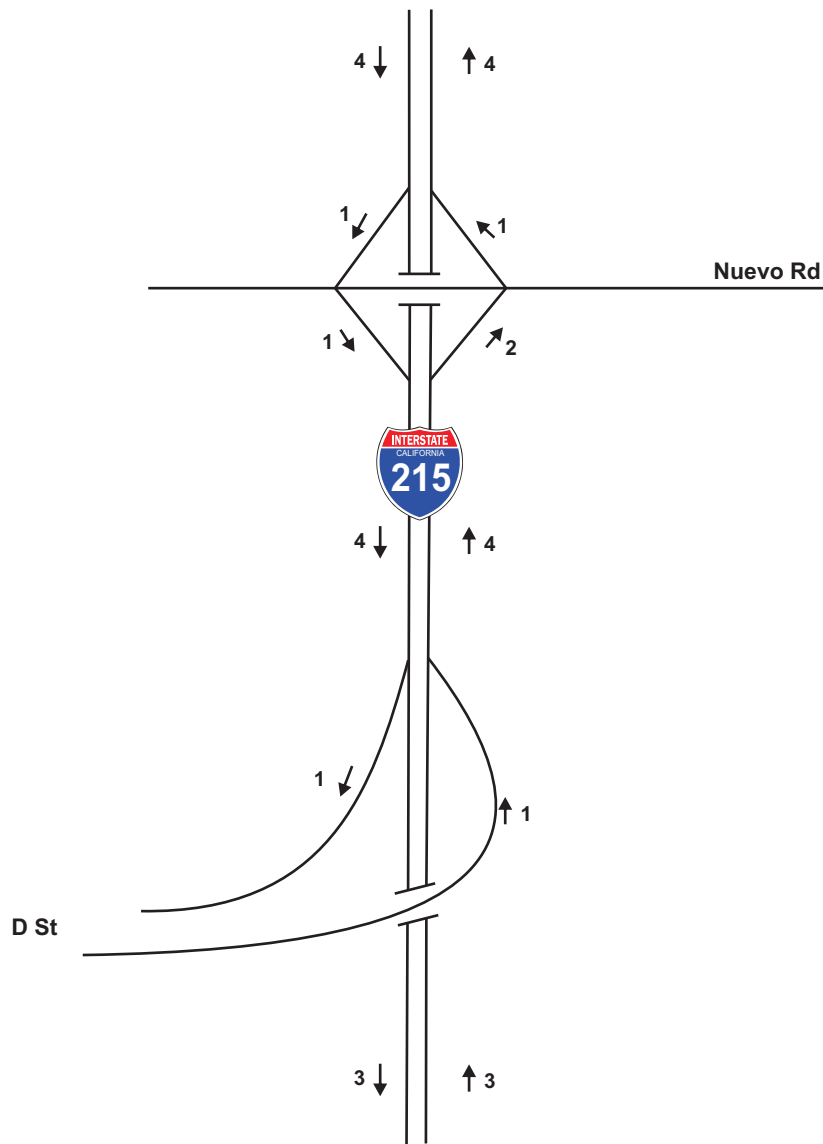

Note:
 One HOV Lane in each direction of travel will be provided North of Nuevo Road in addition to the lanes indicated on I-215.

**Horizon Year (2040)
 Freeway Mainline Lane Geometry
 Interstate 215 - Alternative 9 Modified**

Figure 7-40c

- Legend**
- Direction of Travel
 - X : Number of Lanes (Mixed Flow)



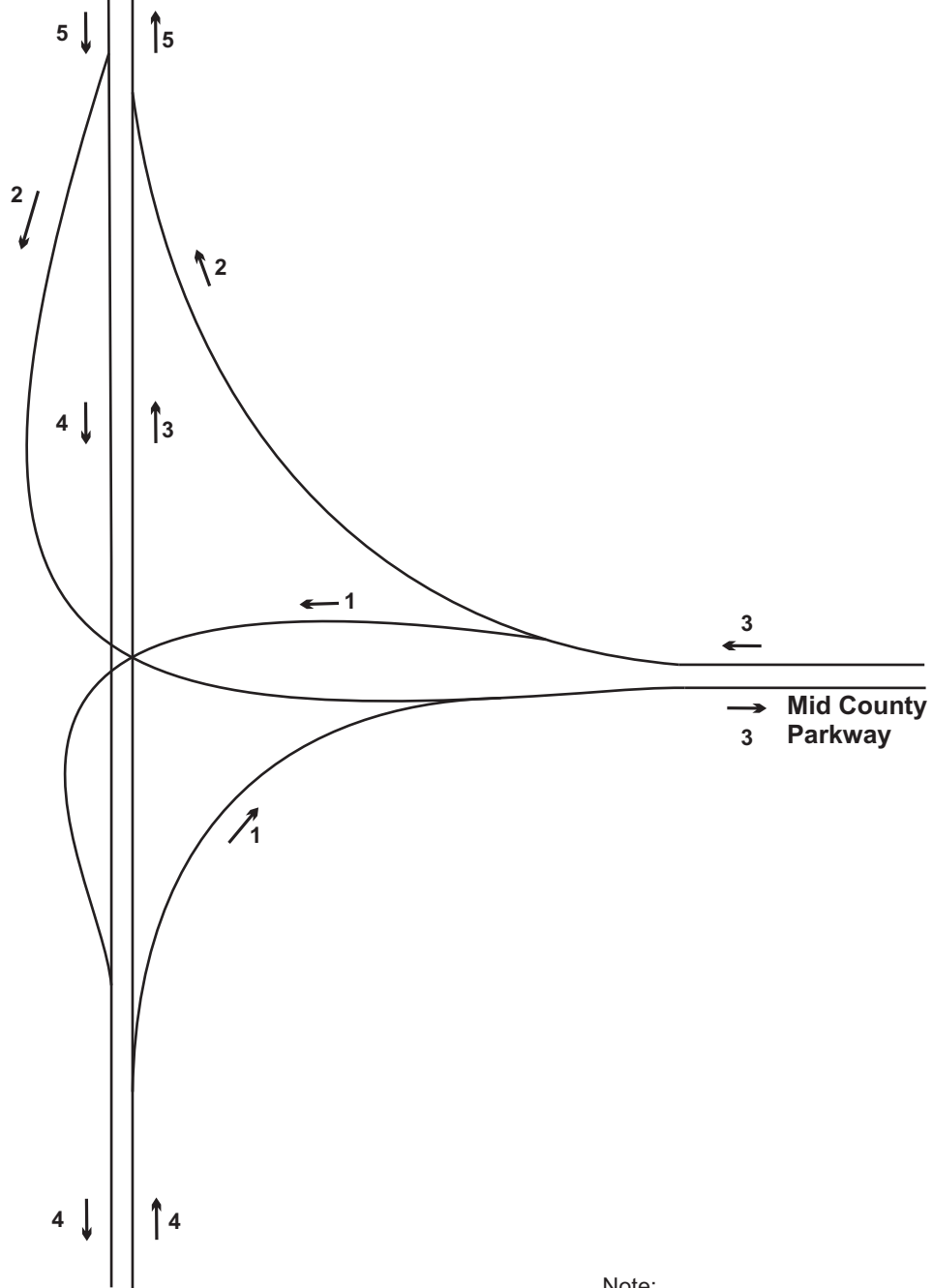

Note:
 One HOV Lane in each direction of travel will be provided on I-215 in addition to the lanes indicated.

**Horizon Year (2040) MCP/I-215 Interchange Area
 Lane Geometry - Alternative 9 Modified**

Figure 7-41

Legend
 → Direction of Travel
 X : Number of Lanes (Mixed Flow)



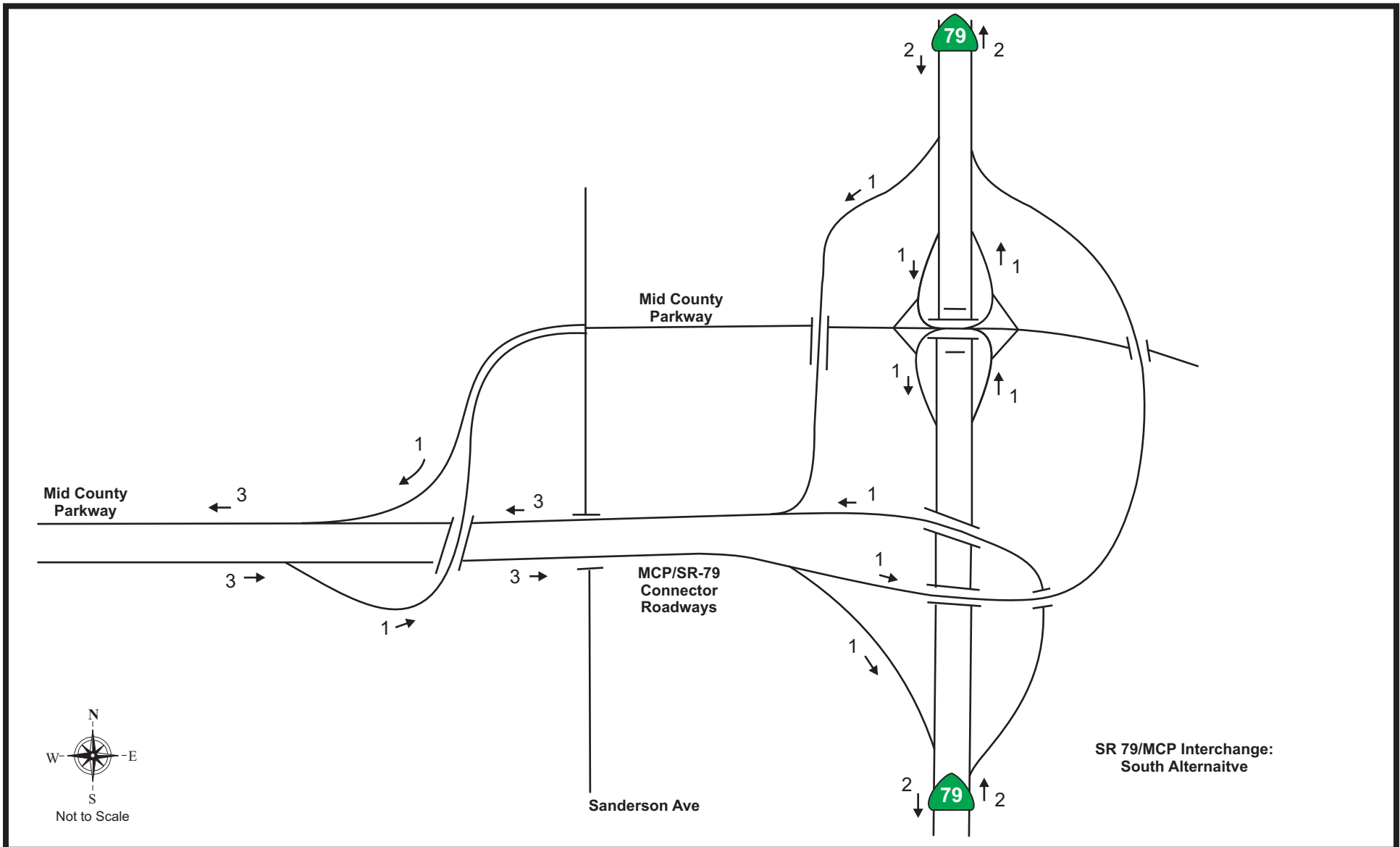

**Horizon Year (2040) MCP/SR-79 Interchange Area
Lane Geometry - Alternative 9 Modified**

Figure 7-42

Legend

← Number of Lanes
X



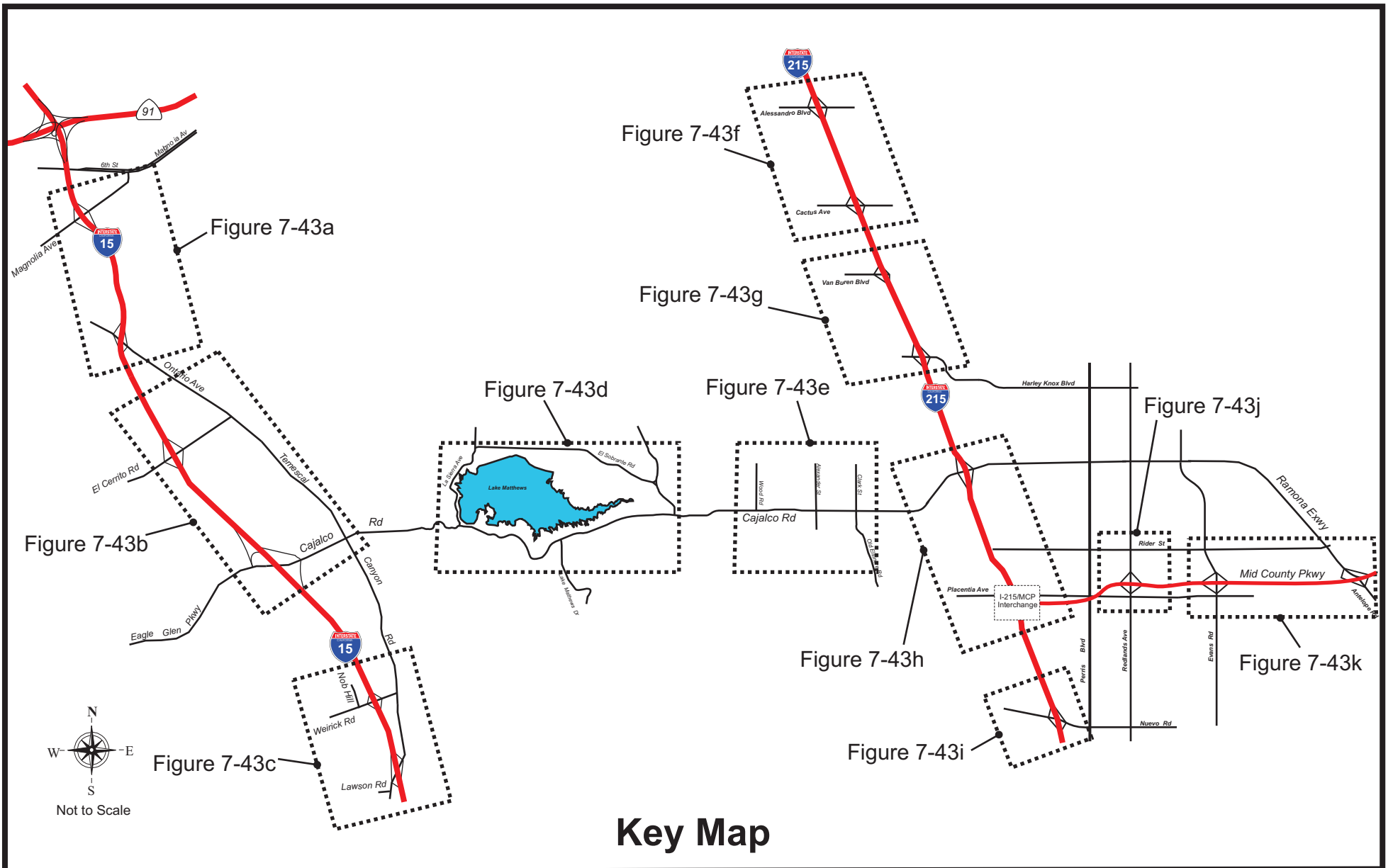

**Horizon Year (2040) Intersection Lane Geometry
Alternative 9 Modified**

Figure 7-43



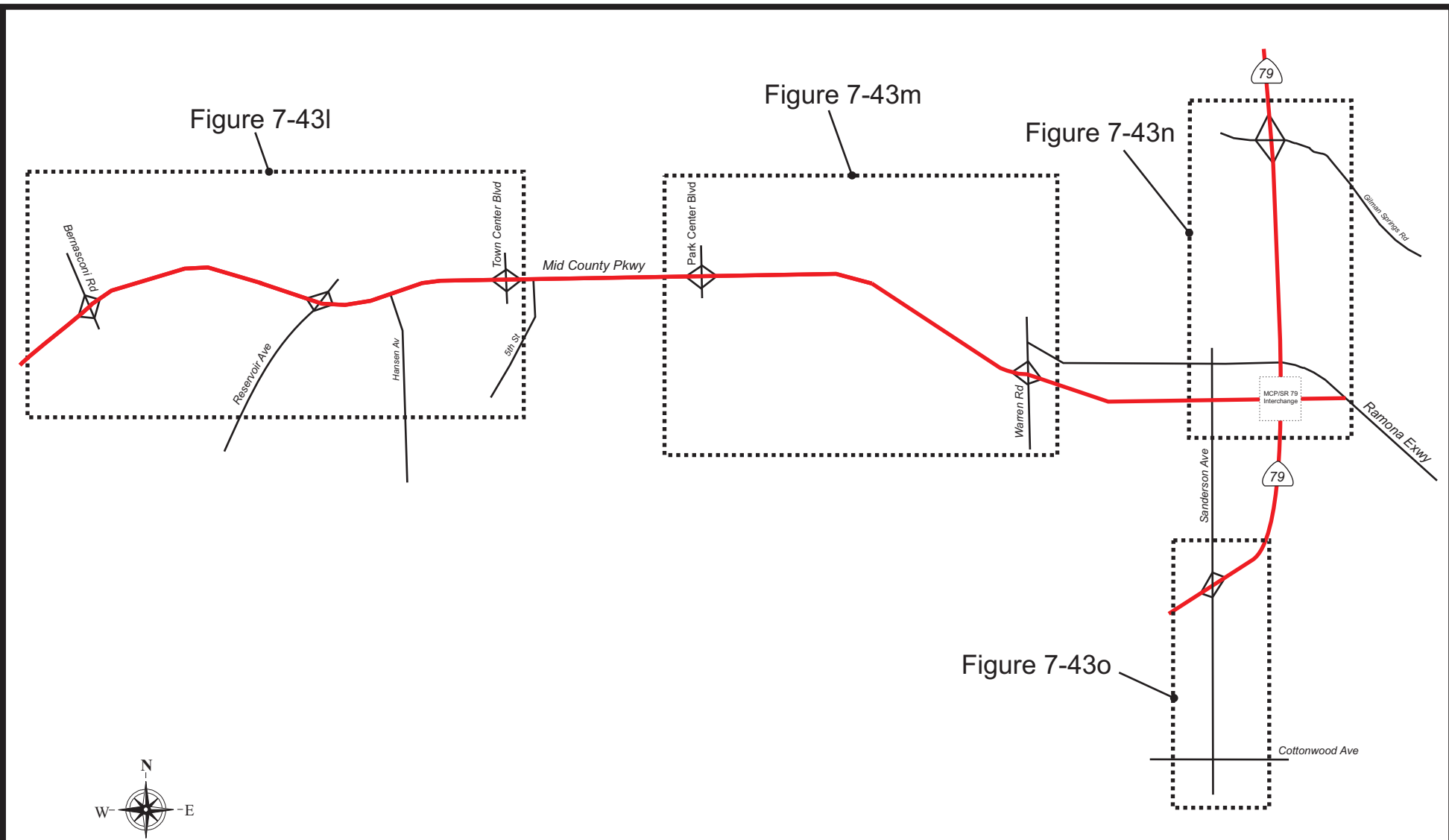

Key Map

**Horizon Year (2040) Intersection Lane Geometry
Alternative 9 Modified**

Figure 7-43 (cont.)

Legend:

 Figure Areas



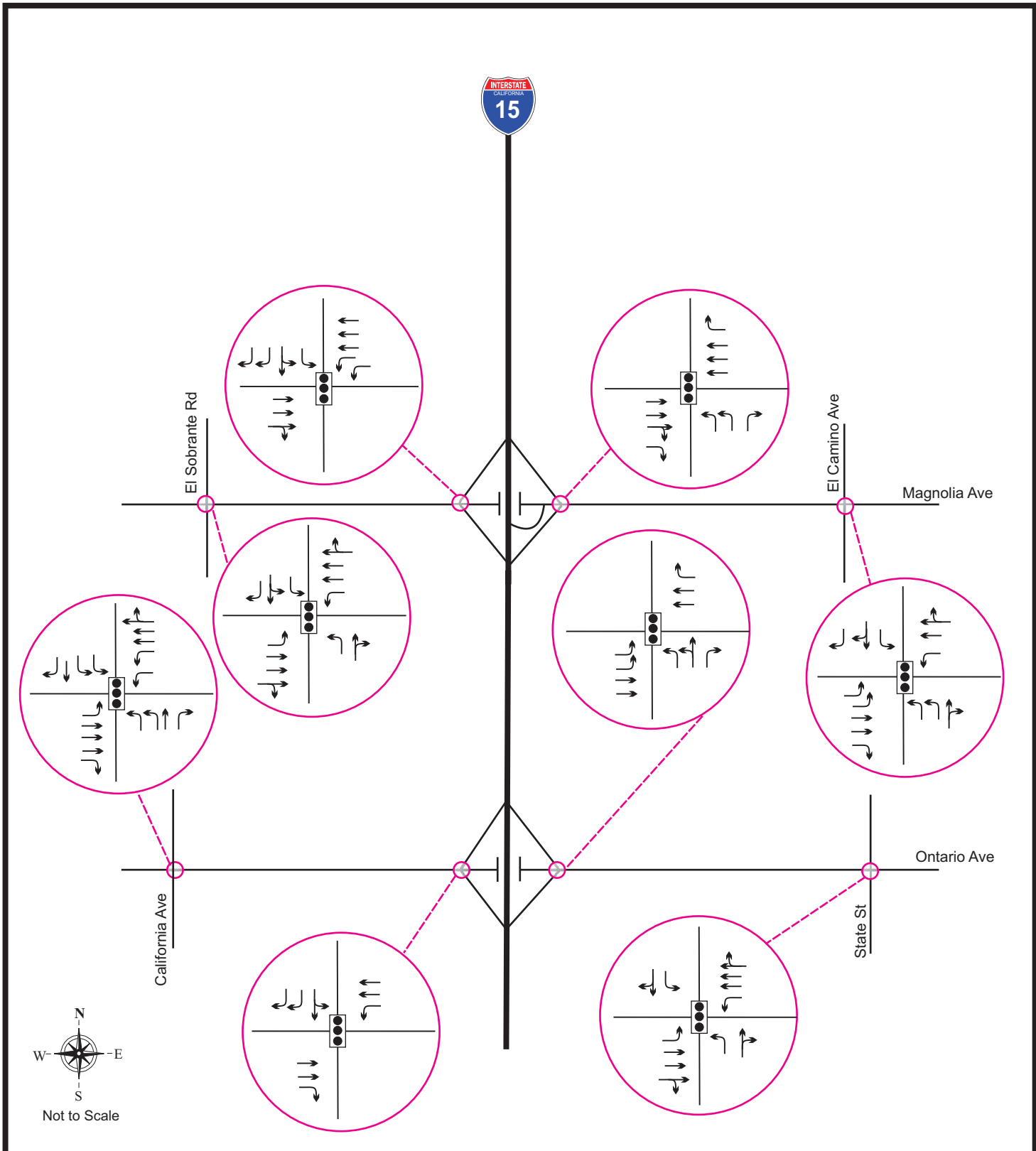

**Horizon Year (2040) Intersection
Lane Geometry - Alternative 9 Modified**

Figure 7-43a

Legend:



Signal



Traffic Lane



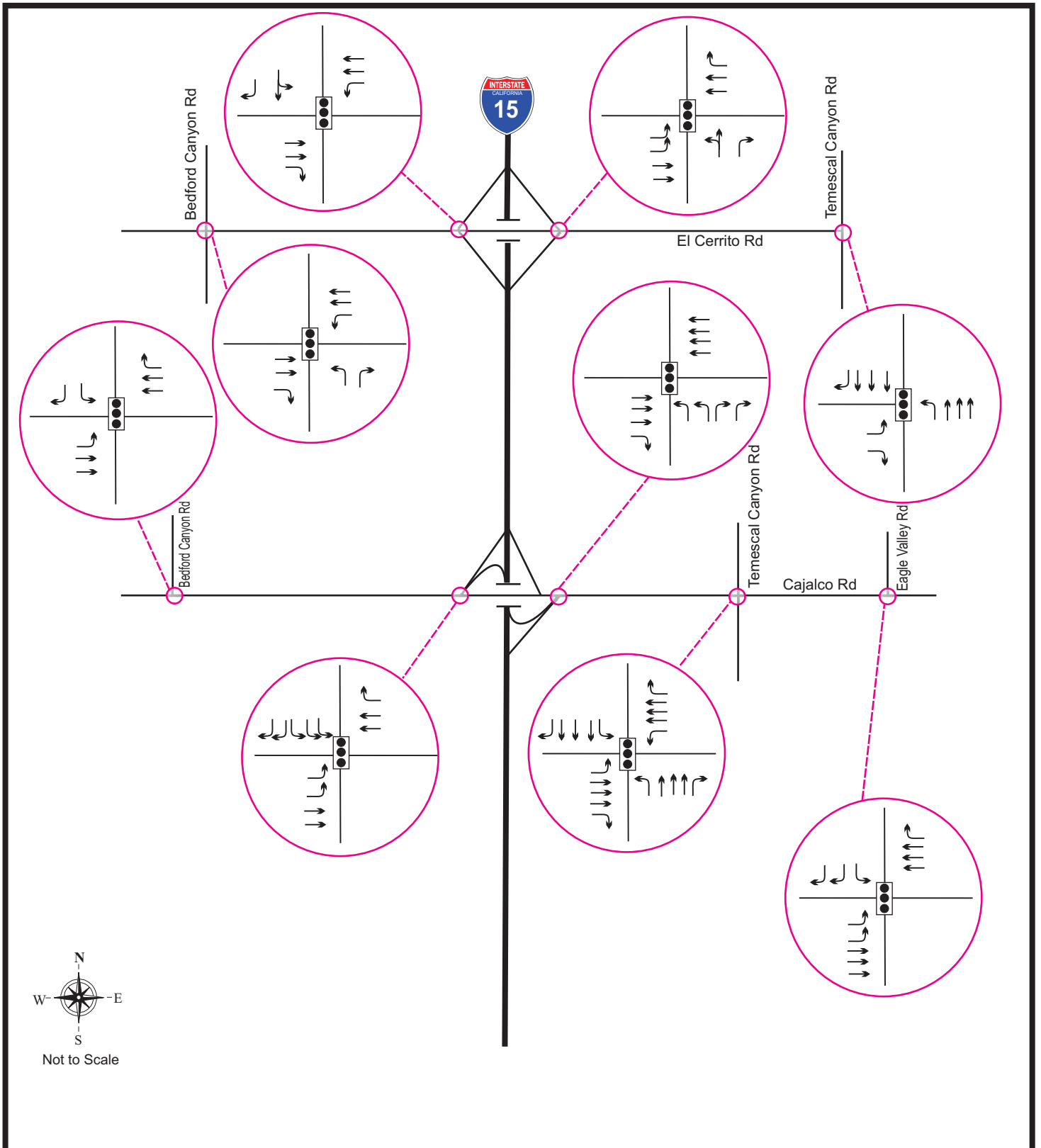

**Horizon Year (2040) Intersection
Lane Geometry - Alternative 9 Modified**

Figure 7-43b

Legend:



Signal



Traffic Lane



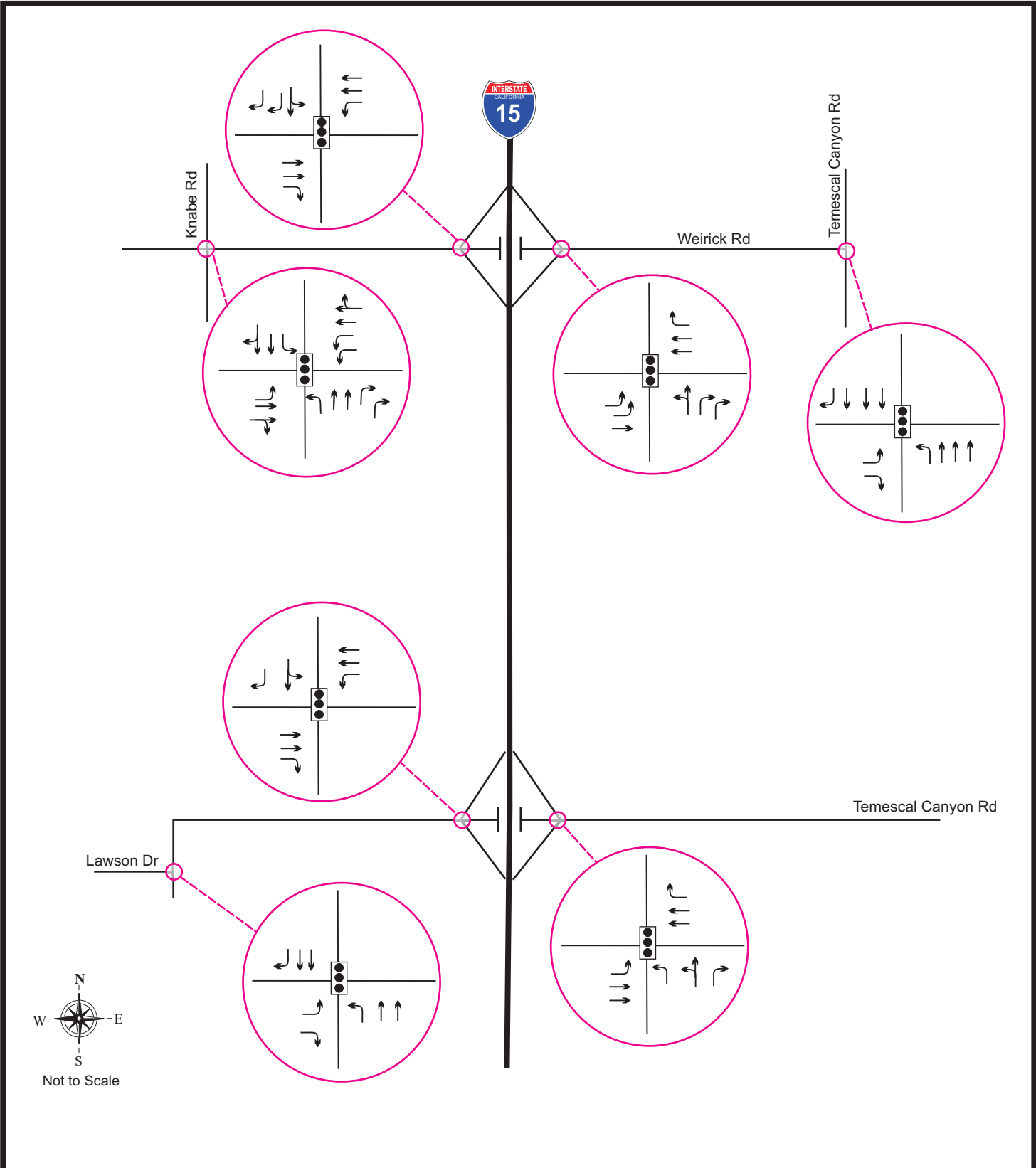

**Horizon Year (2040) Intersection
Lane Geometry - Alternative 9 Modified**

Figure 7-43c

Legend:

-  Signal
-  Traffic Lane



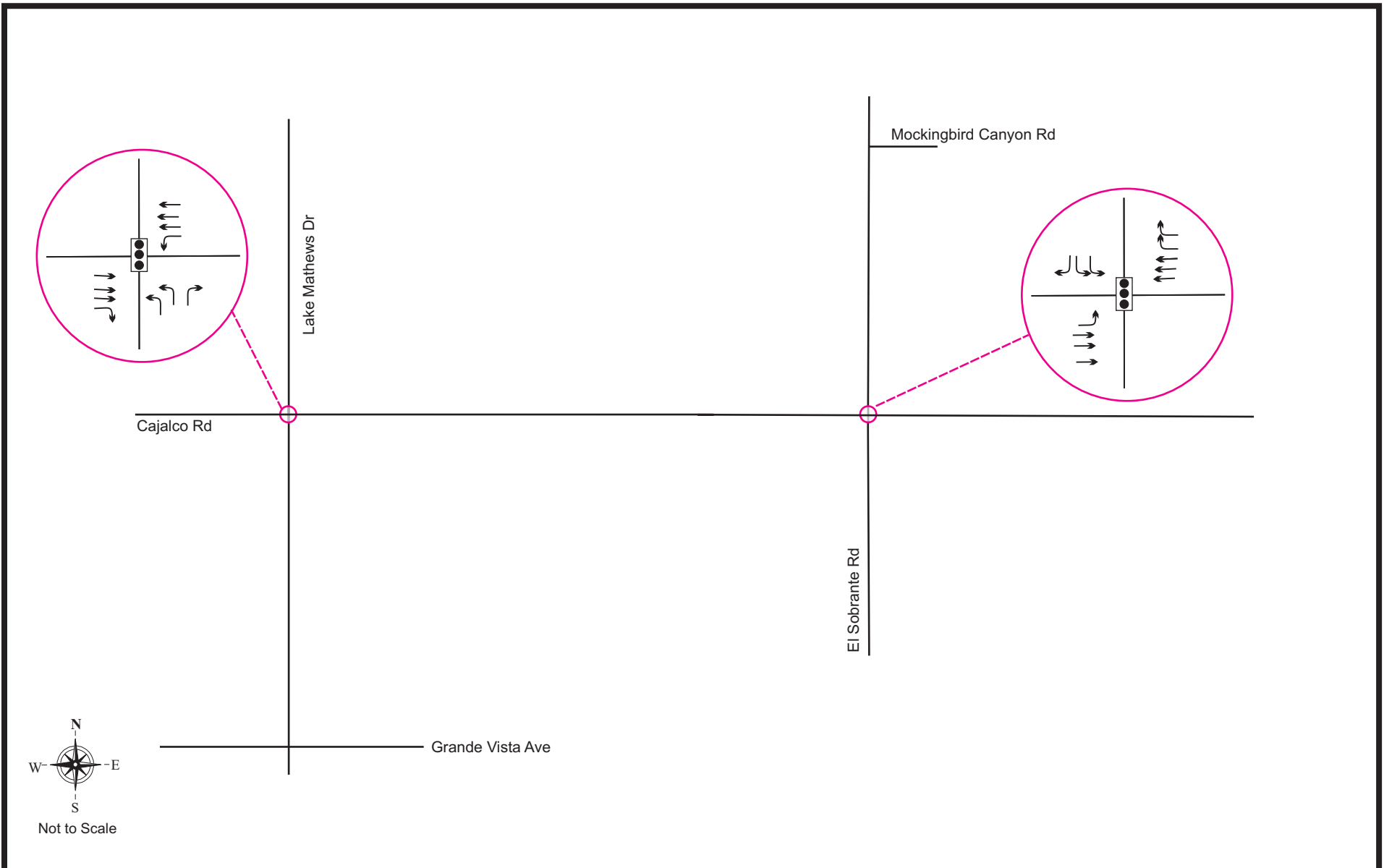

**Horizon Year (2040) Intersection
Lane Geometry - Alternative 9 Modified**

Figure 7-43d

Legend:



Signal



Traffic Lane



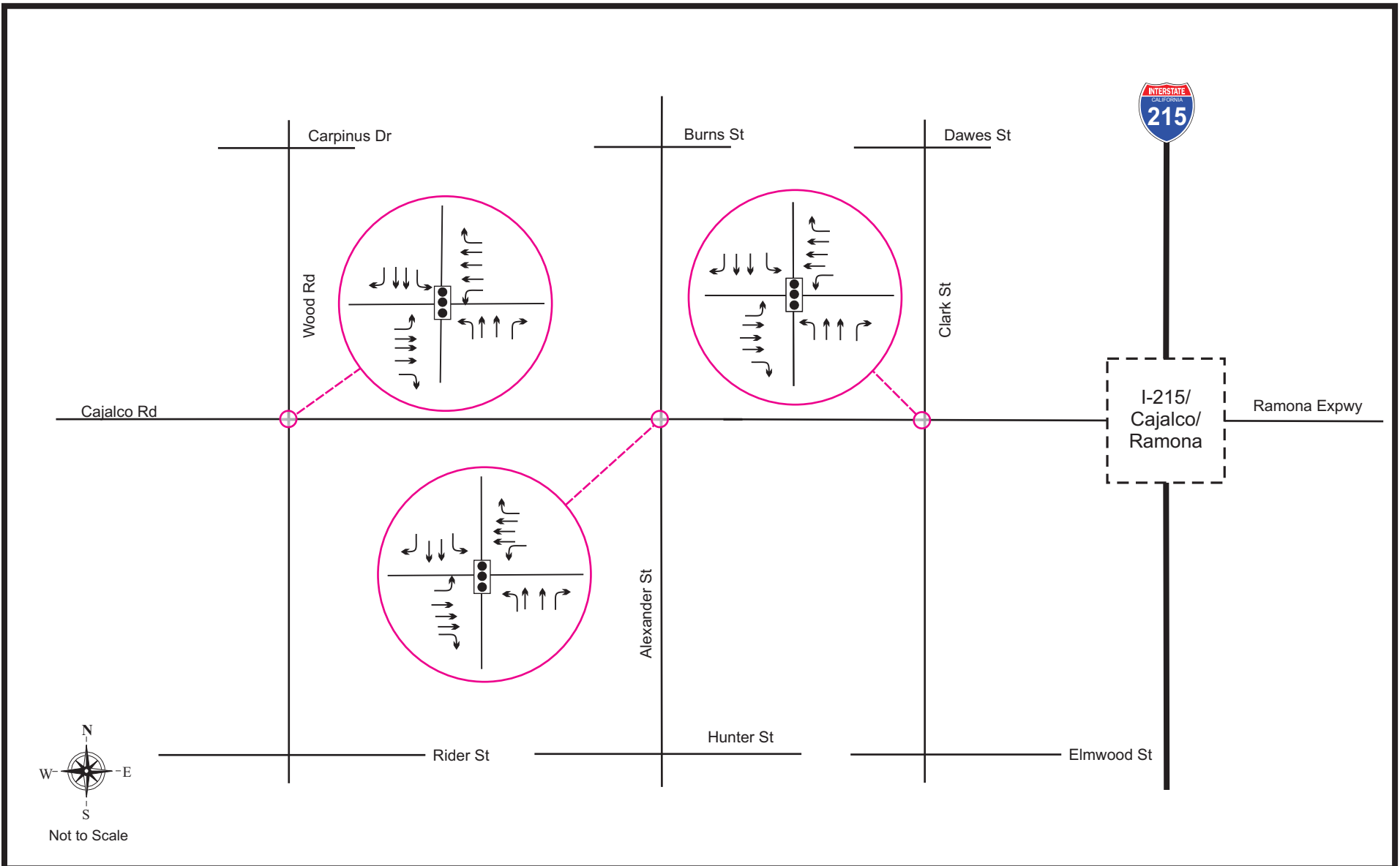

**Horizon Year (2040) Intersection
Lane Geometry - Alternative 9 Modified**

Figure 7-43e

Legend:



-  Signal
-  Traffic Lane

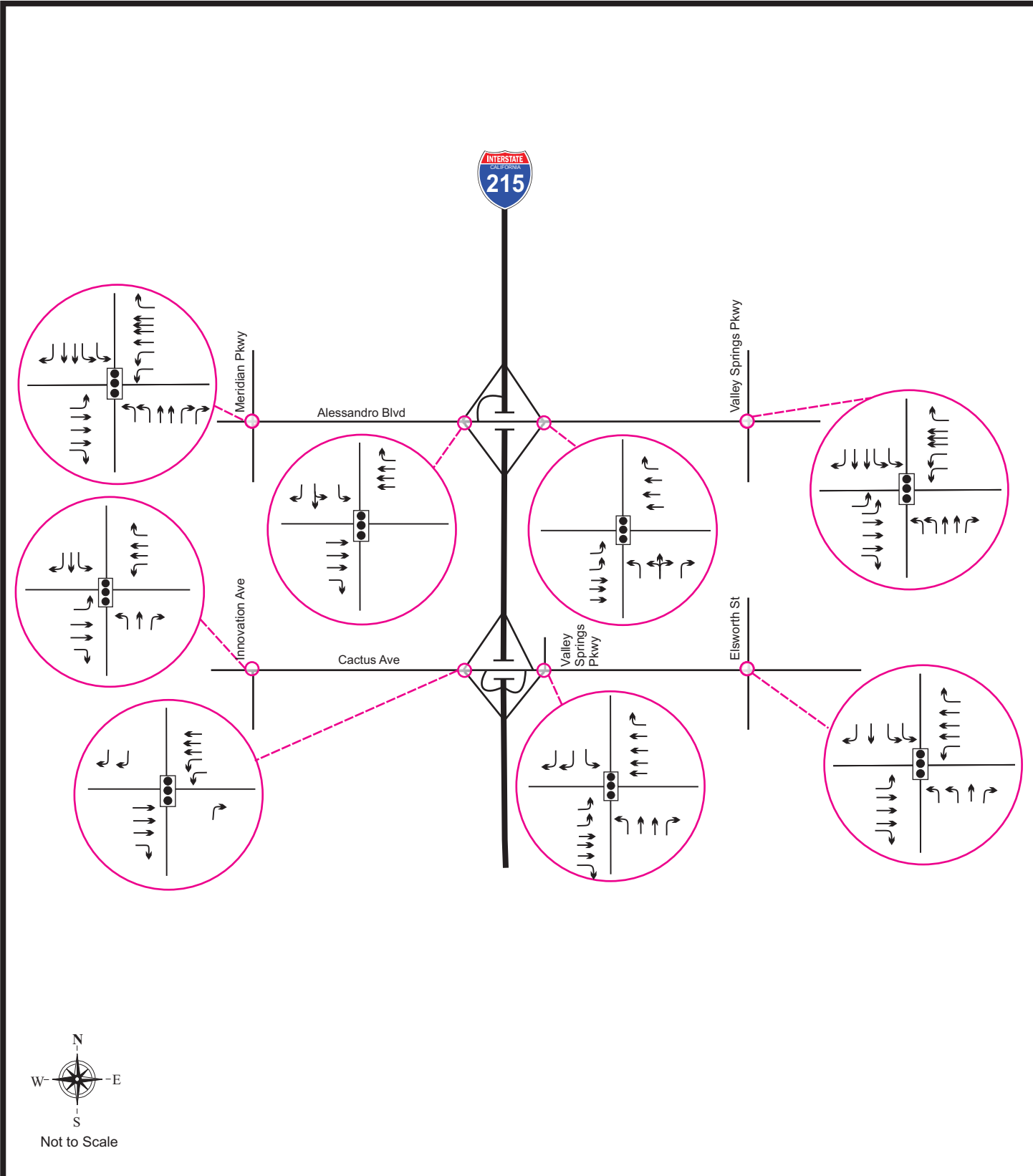



**Horizon Year (2040) Intersection
Lane Geometry - Alternative 9 Modified**

Figure 7-43f



Legend:
 Signal  Traffic Lane

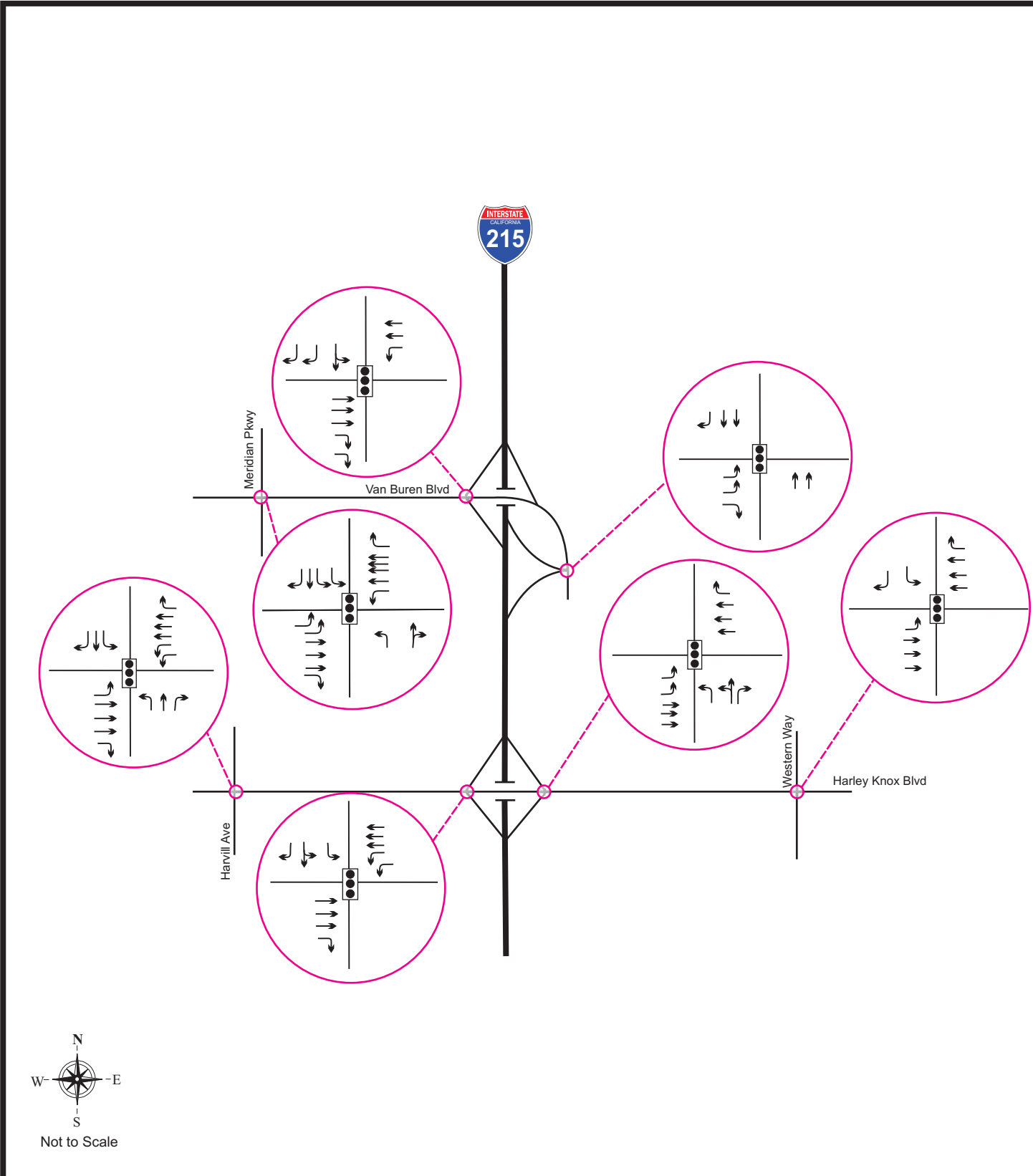



**Horizon Year (2040) Intersection
Lane Geometry - Alternative 9 Modified**

Figure 7-43g

- Legend:**
-  Signal
 -  Traffic Lane



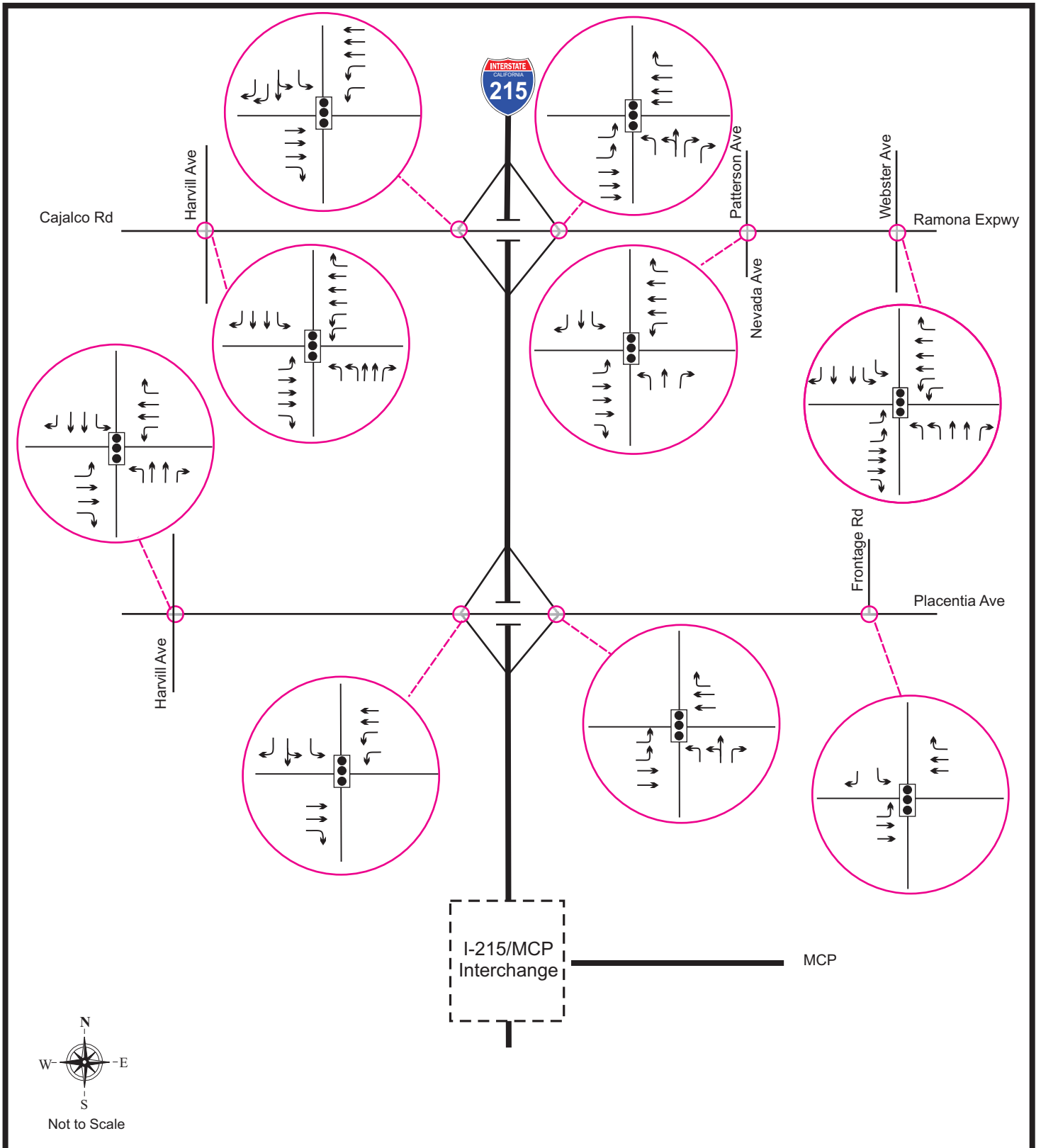

**Horizon Year (2040) Intersection
Lane Geometry - Alternative 9 Modified**

Figure 7-43h

Legend:



Signal



Traffic Lane



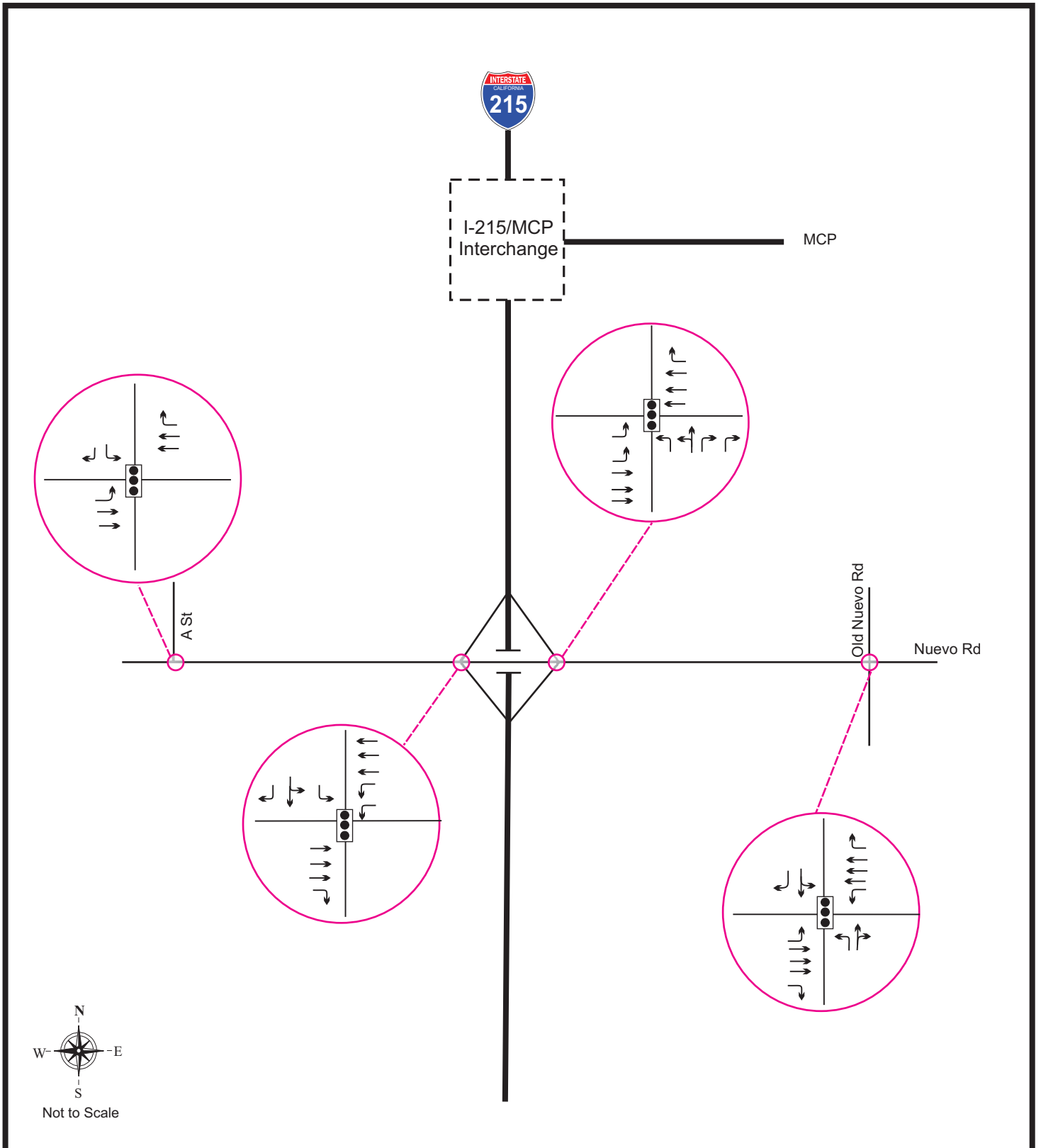

**Horizon Year (2040) Intersection
Lane Geometry - Alternative 9 Modified**

Figure 7-43i

Legend:



Signal



Traffic Lane



VRPA TECHNOLOGIES, INC.

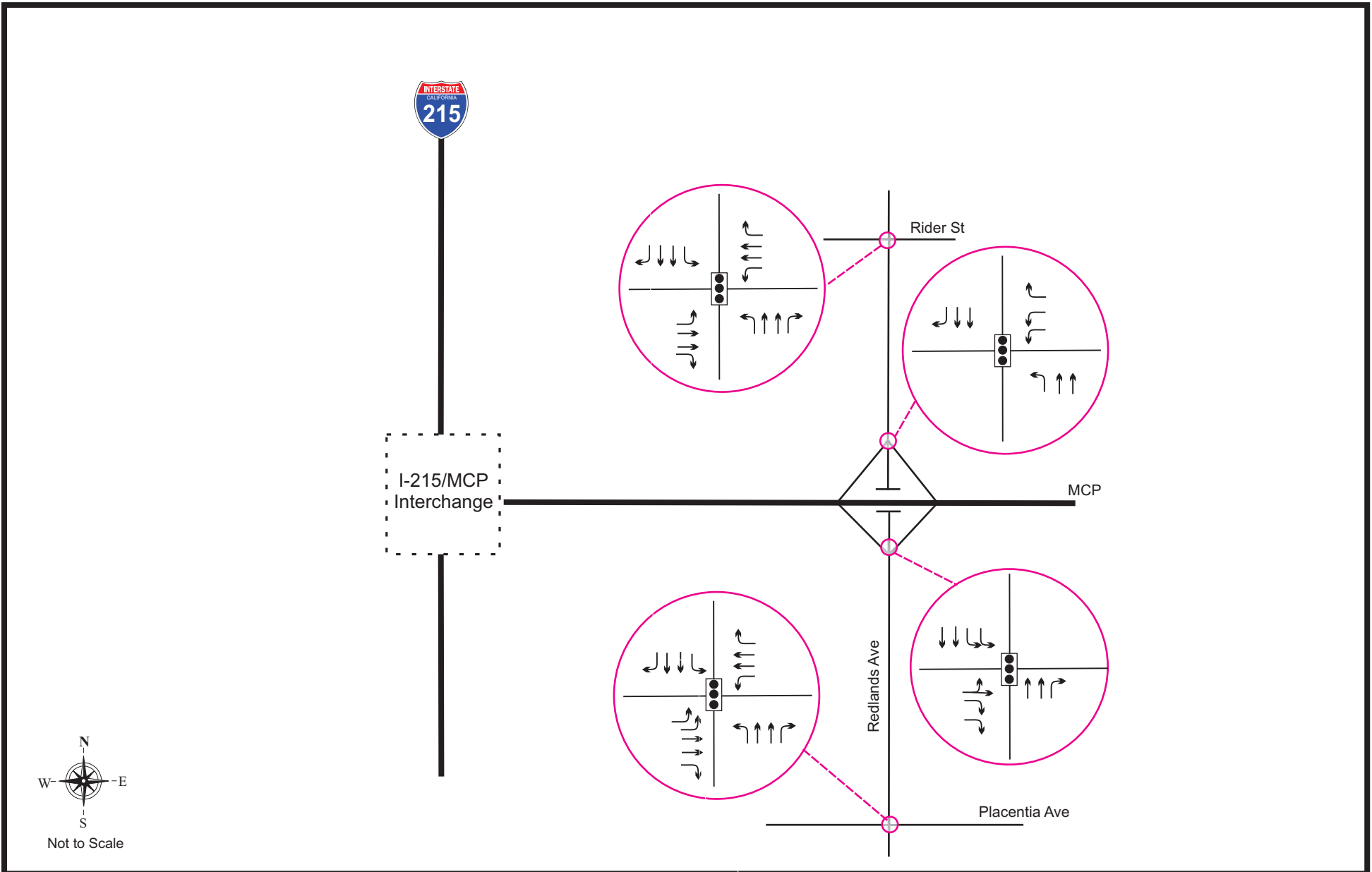

**Horizon Year (2040) Intersection
Lane Geometry - Alternative 9 Modified**

Figure 7-43j

Legend:



Signal



Traffic Lane



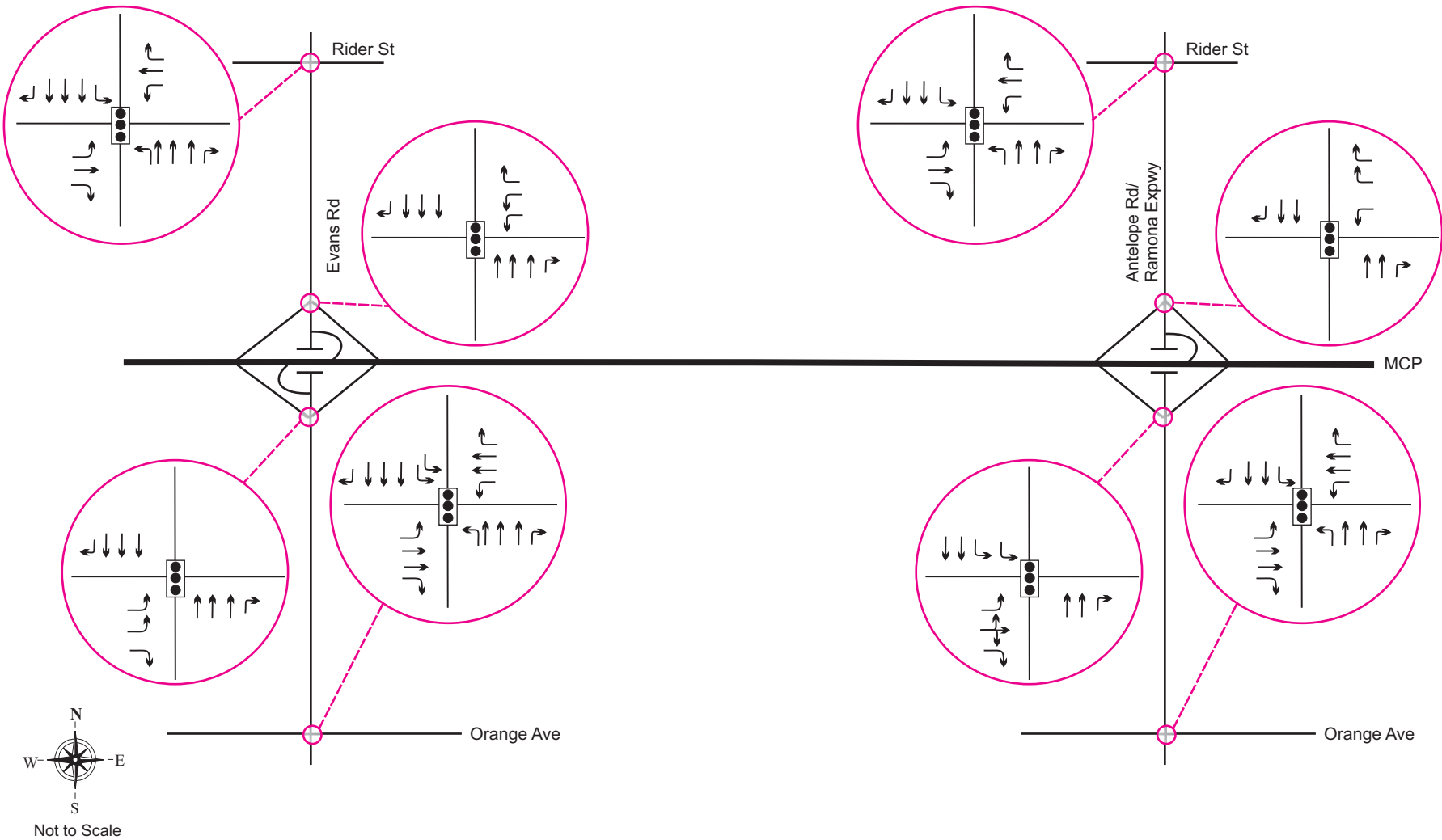

**Horizon Year (2040) Intersection
Lane Geometry - Alternative 9 Modified**

Figure 7-43k

Legend:



Signal



Traffic Lane



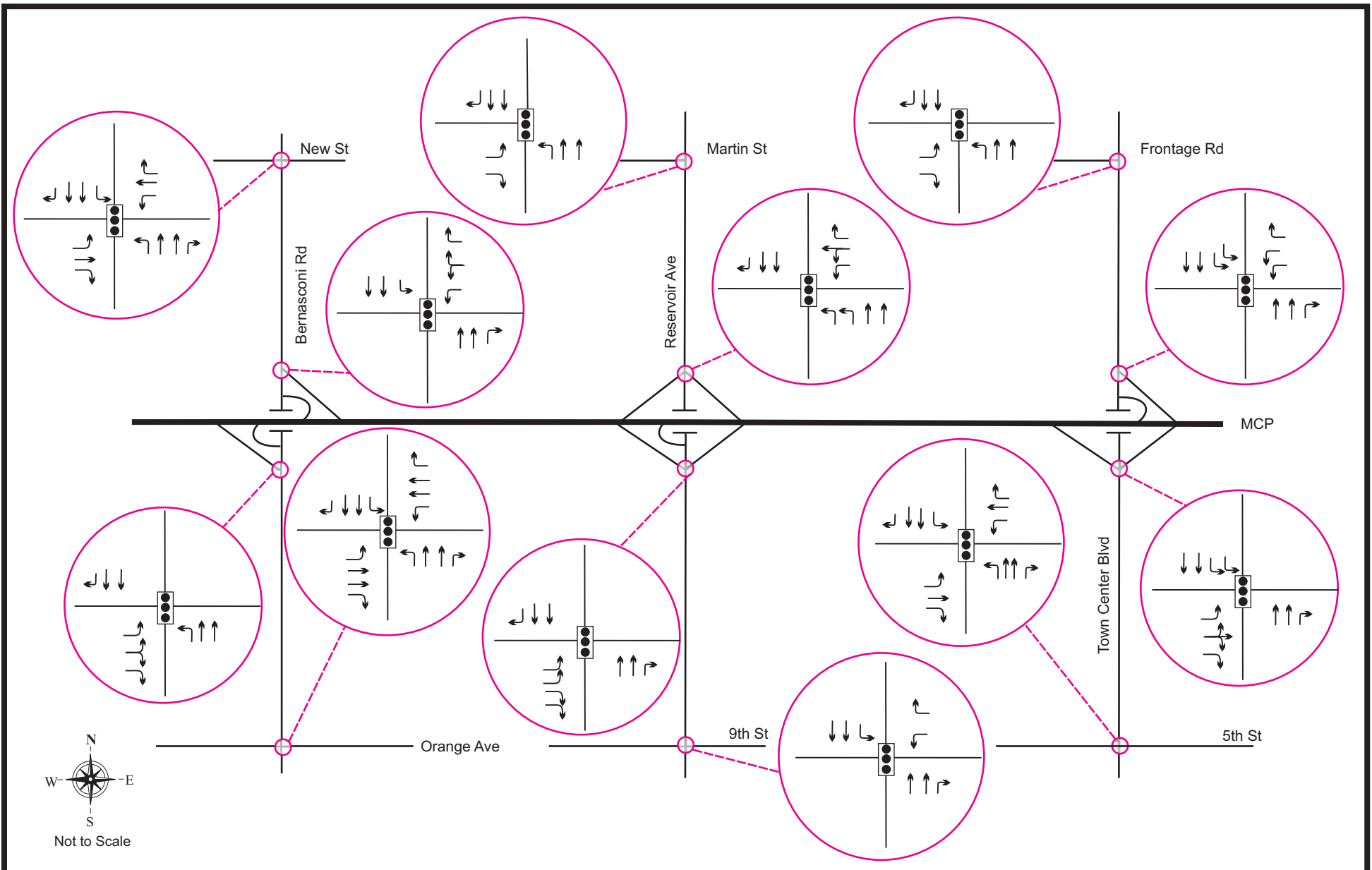

**Horizon Year (2040) Intersection
Lane Geometry - Alternative 9 Modified**

Figure 7-43I

Legend:



Signal



Traffic Lane



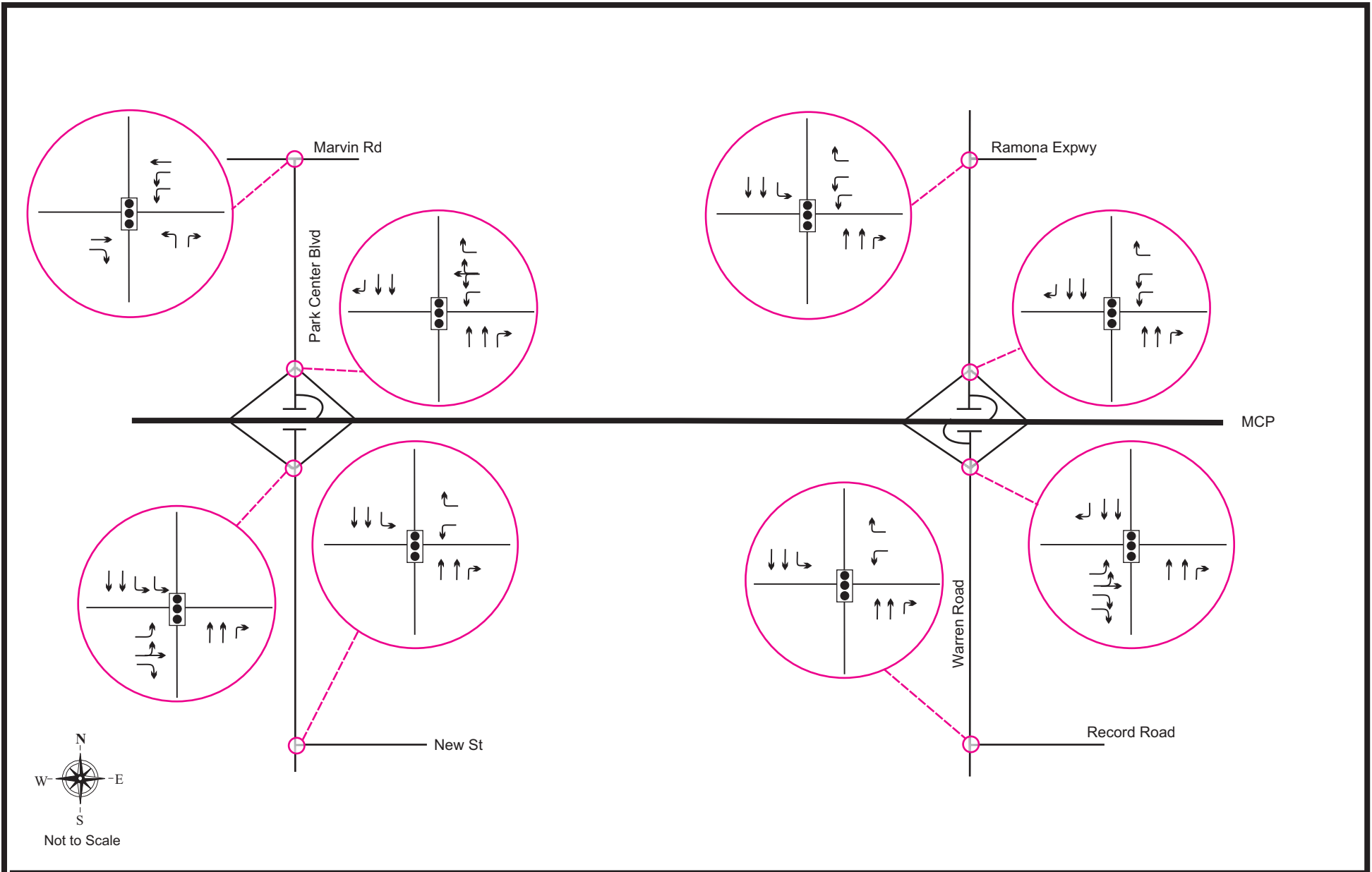

**Horizon Year (2040) Intersection
Lane Geometry - Alternative 9 Modified**

Figure 7-43m

Legend:



Signal



Traffic Lane



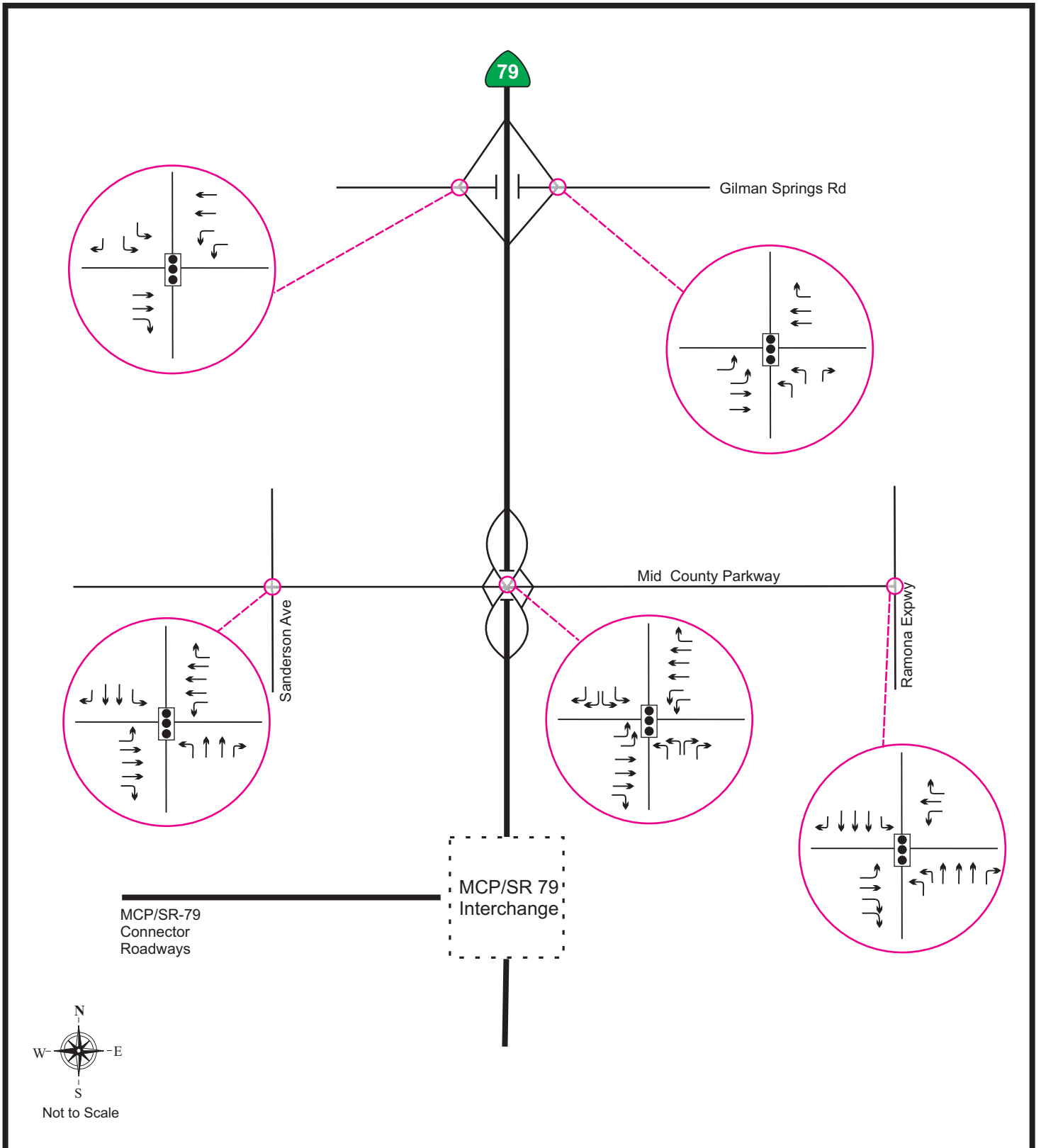

**Horizon Year (2040) Intersection
Lane Geometry - Alternative 9 Modified**

Figure 7-43n

Legend:



Signal



Traffic Lane



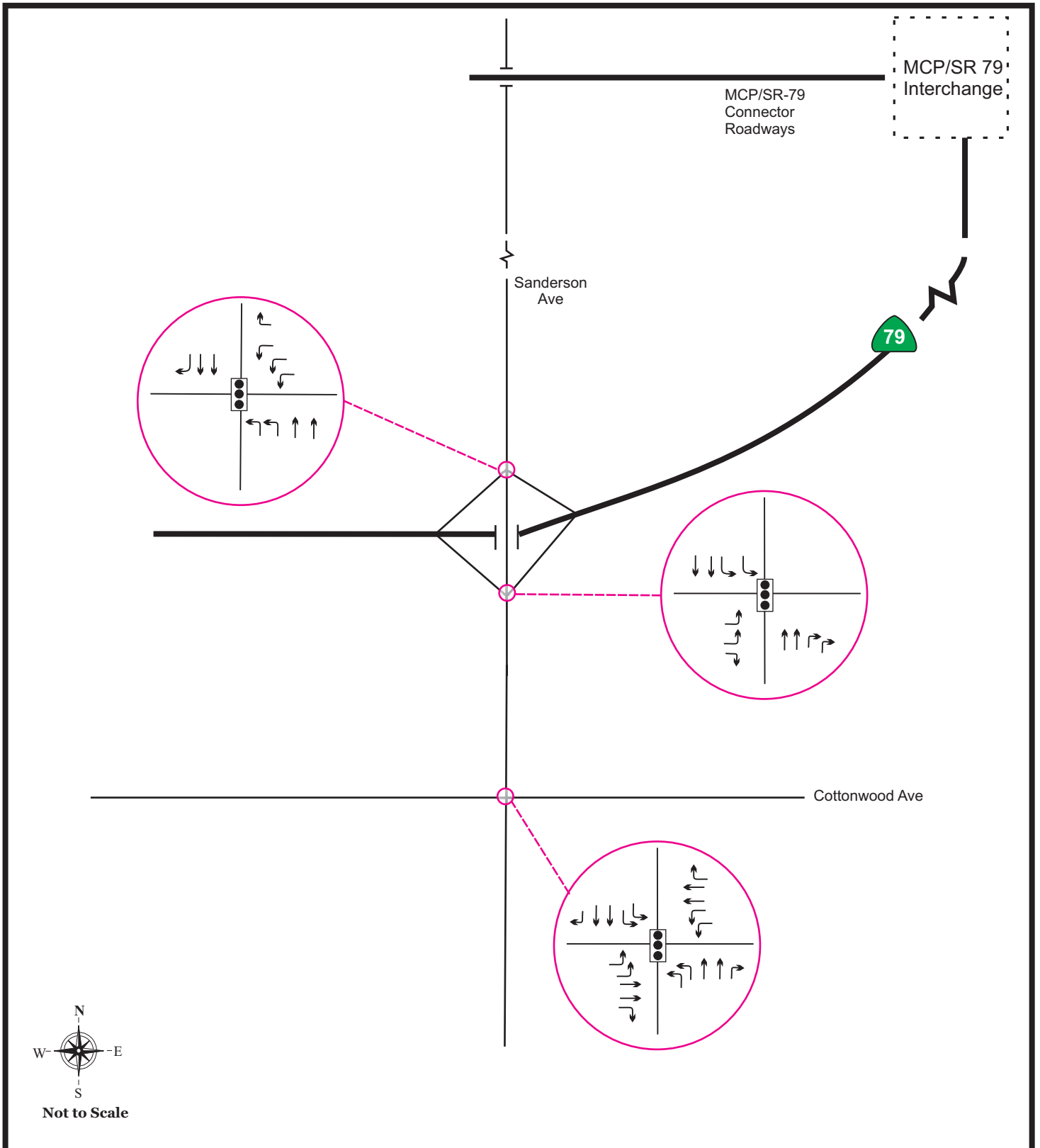

**Horizon Year (2040) Intersection
Lane Geometry - Alternative 9 Modified**

Figure 7-43o

Legend:



Signal



Traffic Lane



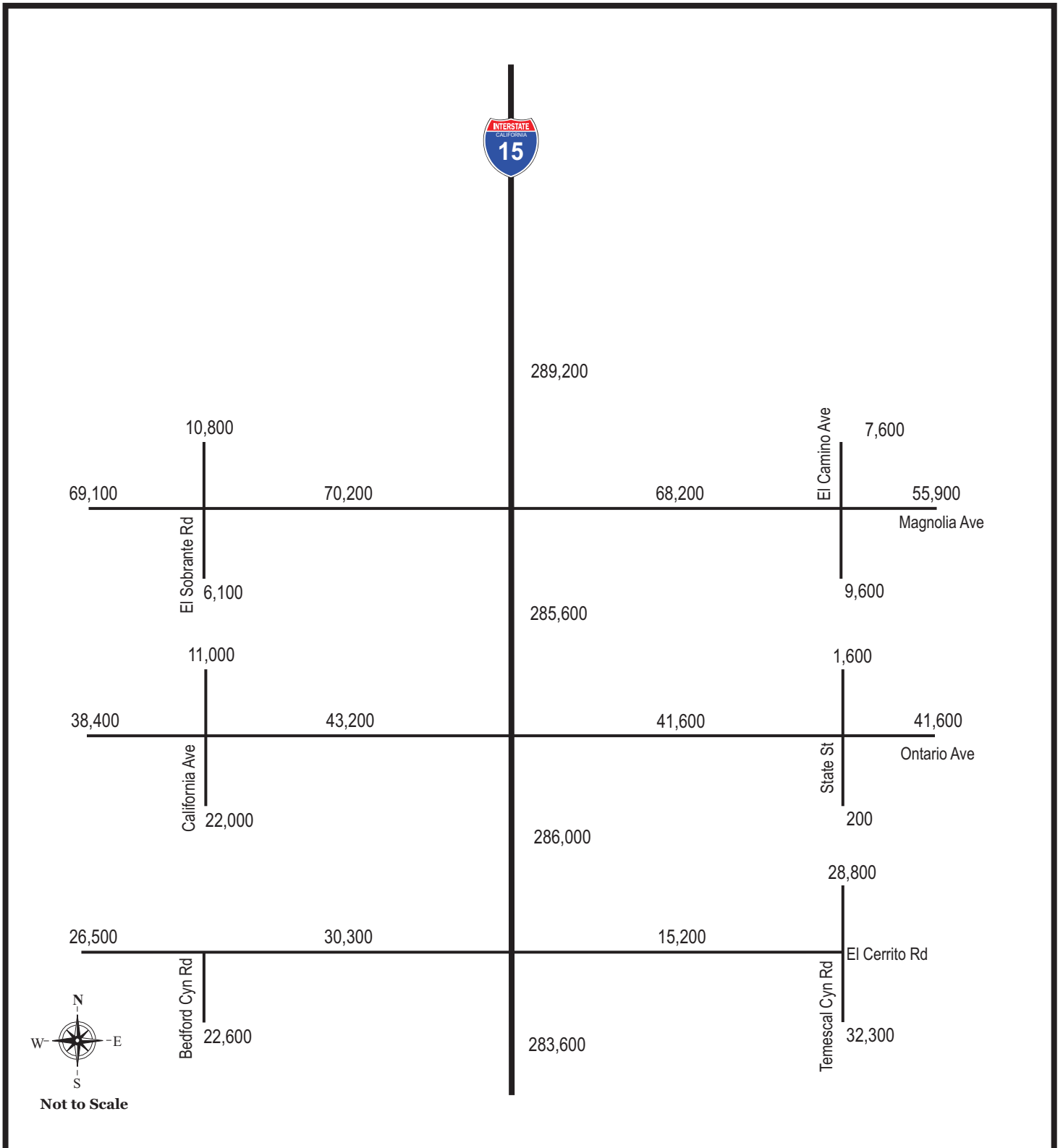

Horizon Year (2040) ADT - Freeway and Street Segments MCP Area - Alternative 9 Modified

Figure 7-44a

Legend:

XX,XXX Average Daily Traffic



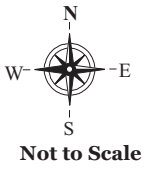
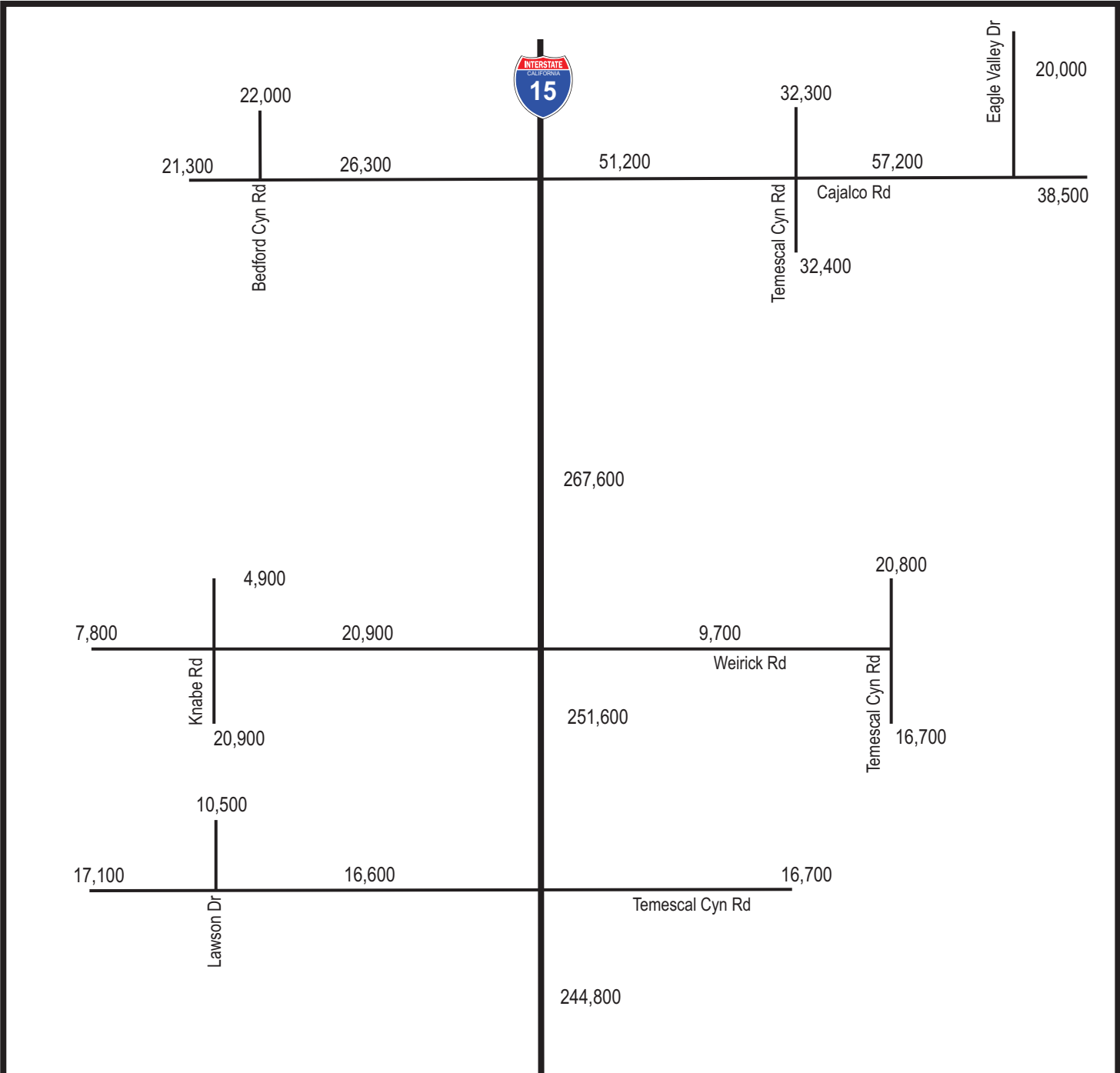

Horizon Year (2040) ADT - Freeway and Street Segments MCP Area - Alternative 9 Modified

Figure 7-44b

Legend:

XX,XXX Average Daily Traffic



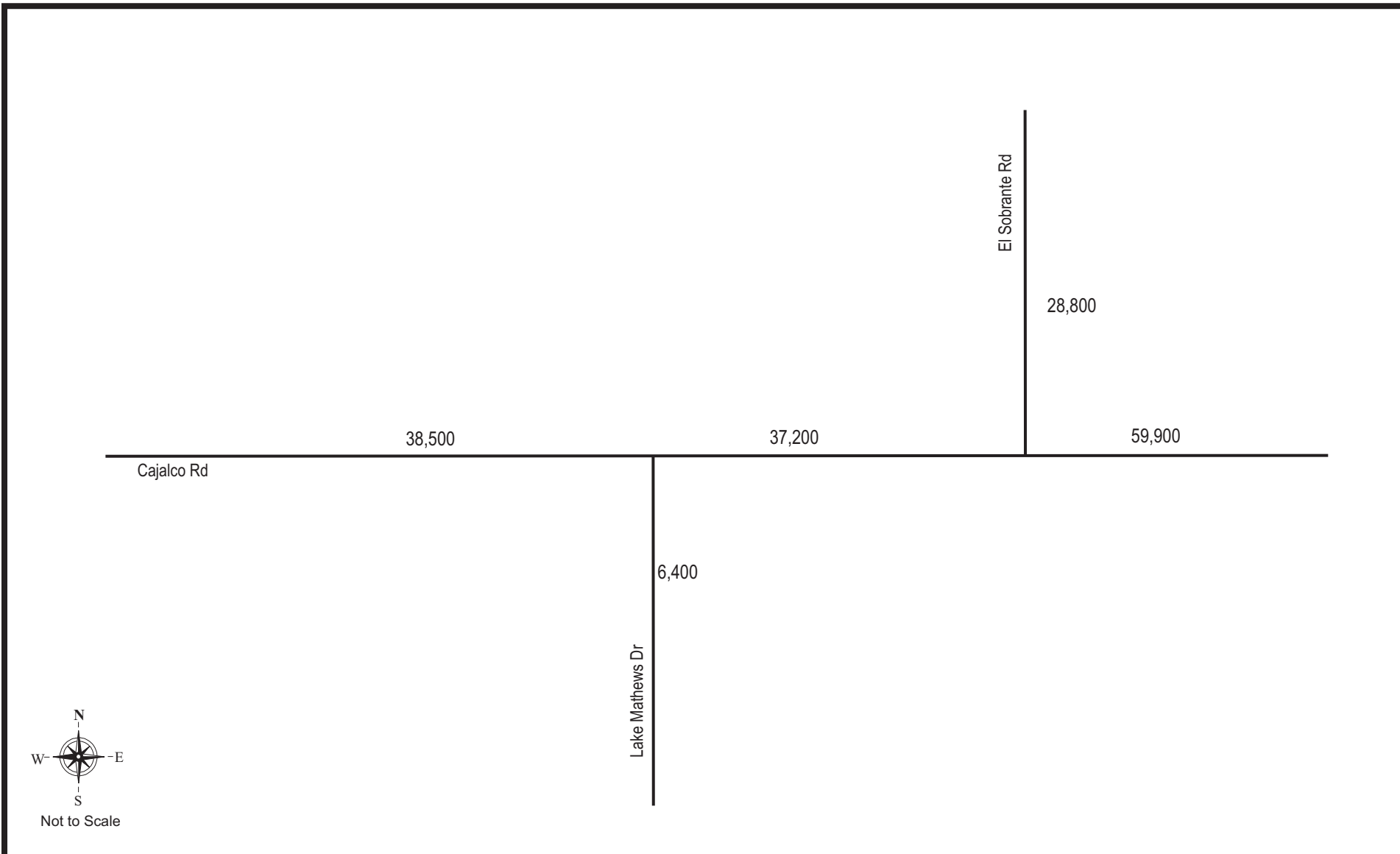

Horizon Year (2040) ADT - Freeway and Street Segments MCP Area - Alternative 9 Modified

Figure 7-44c

Legend:

XX,XXX Average Daily Traffic



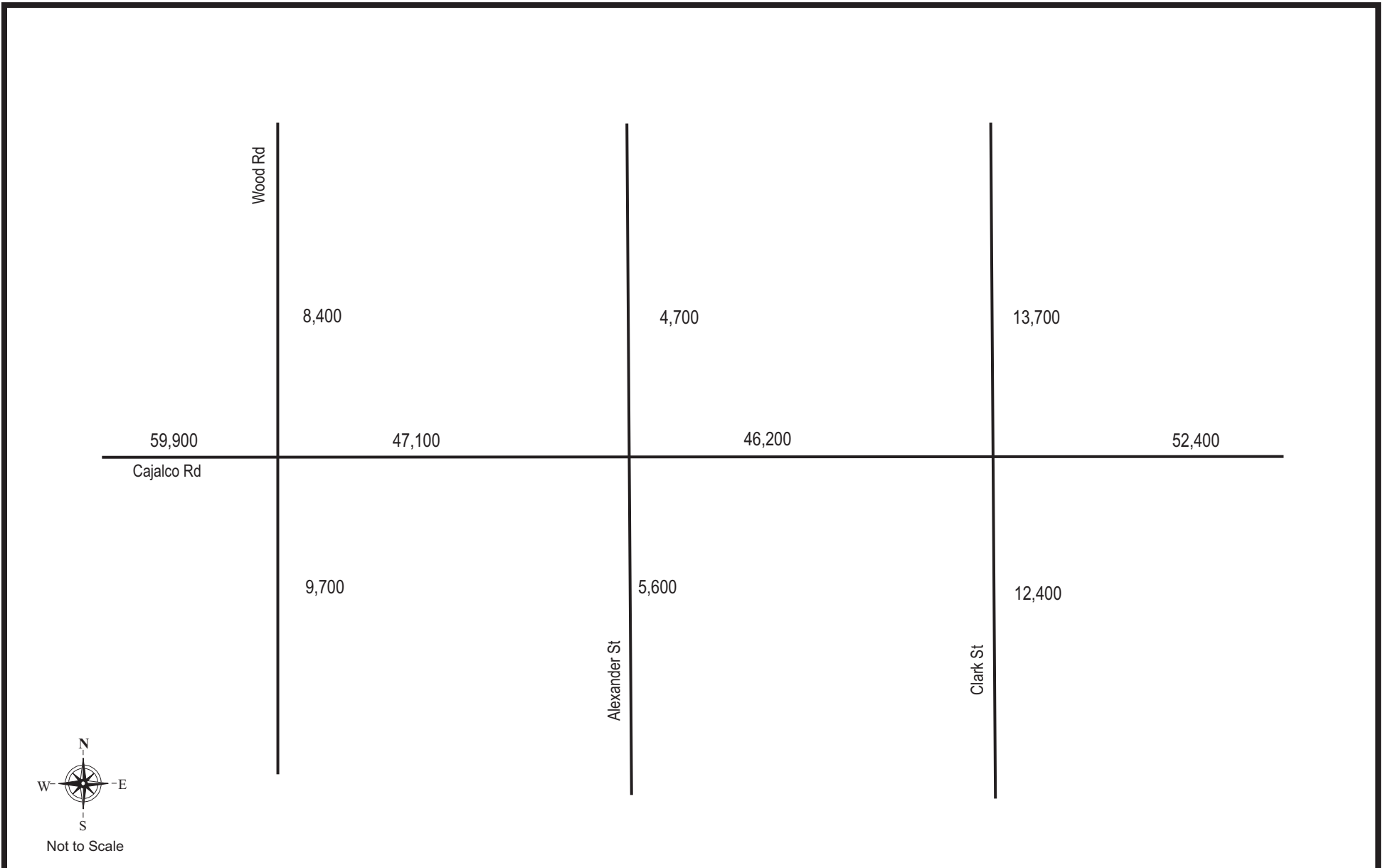

Horizon Year (2040) ADT - Freeway and Street Segments MCP Area - Alternative 9 Modified

Figure 7-44d

Legend:

XX,XXX Average Daily Traffic



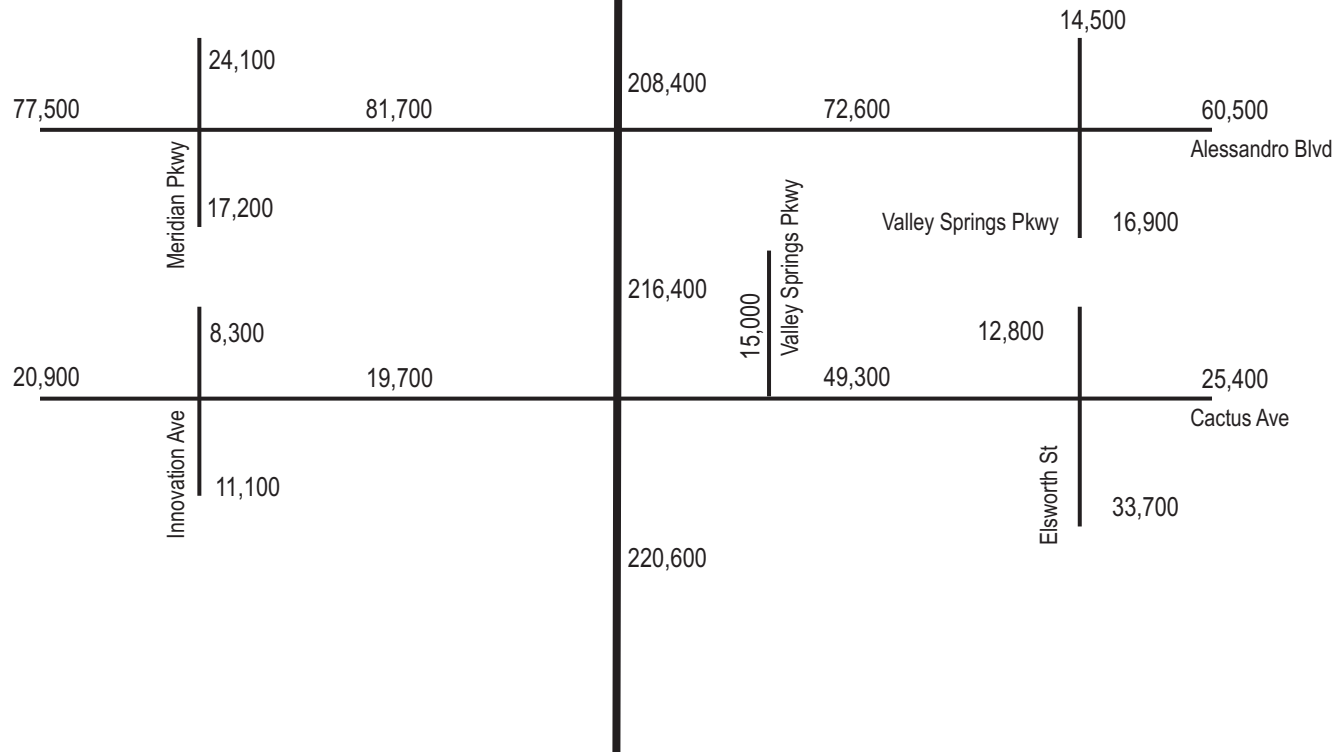

Not to Scale

Horizon Year (2040) ADT - Freeway and Street Segments MCP Area - Alternative 9 Modified

Figure 7-44e

Legend:

XX,XXX Average Daily Traffic





Not to Scale

Horizon Year (2040) ADT - Freeway and Street Segments MCP Area - Alternative 9 Modified

Figure 7-44f

Legend:

XX,XXX Average Daily Traffic



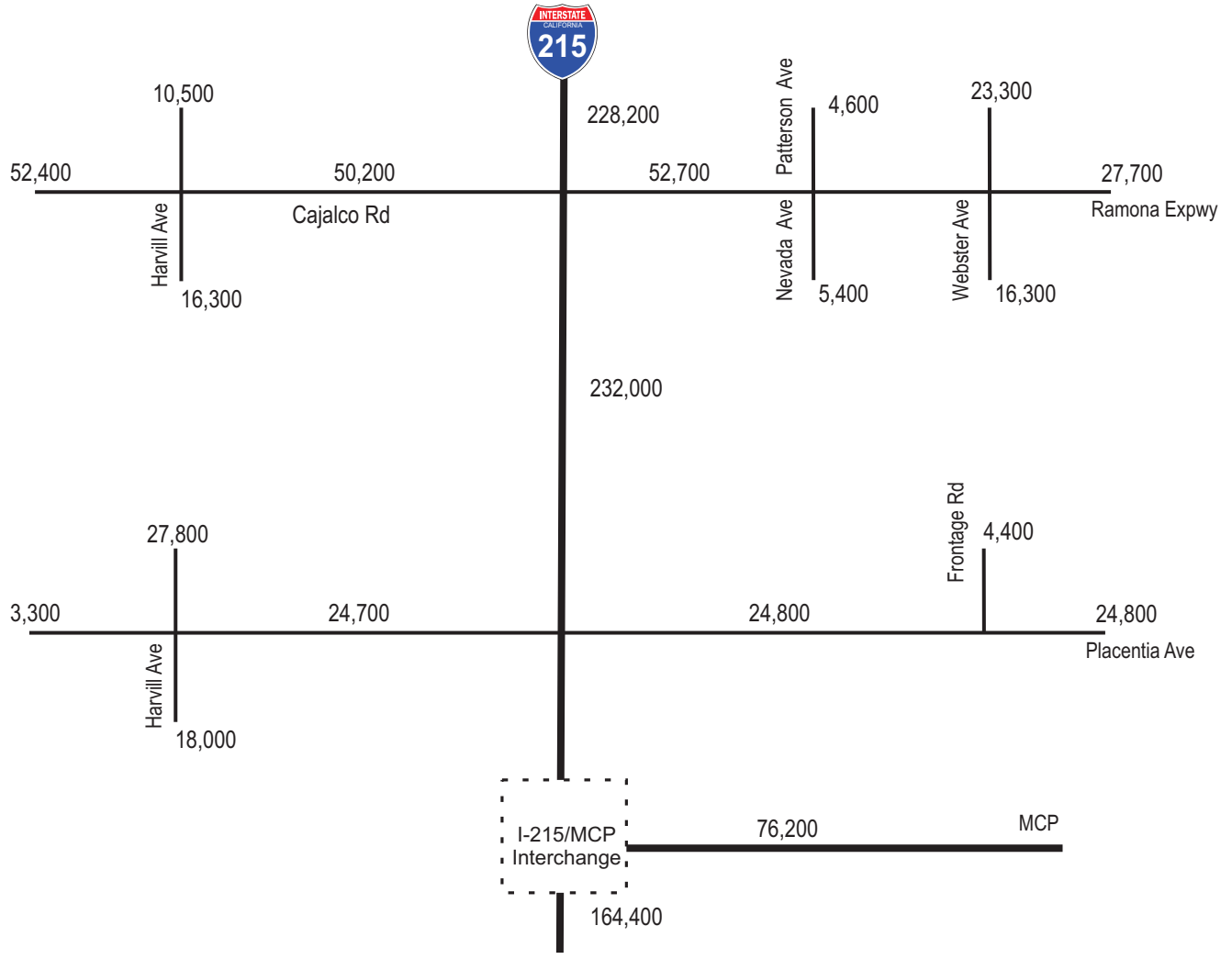

Horizon Year (2040) ADT - Freeway and Street Segments MCP Area - Alternative 9 Modified

Figure 7-44g

Legend:

XX,XXX Average Daily Traffic



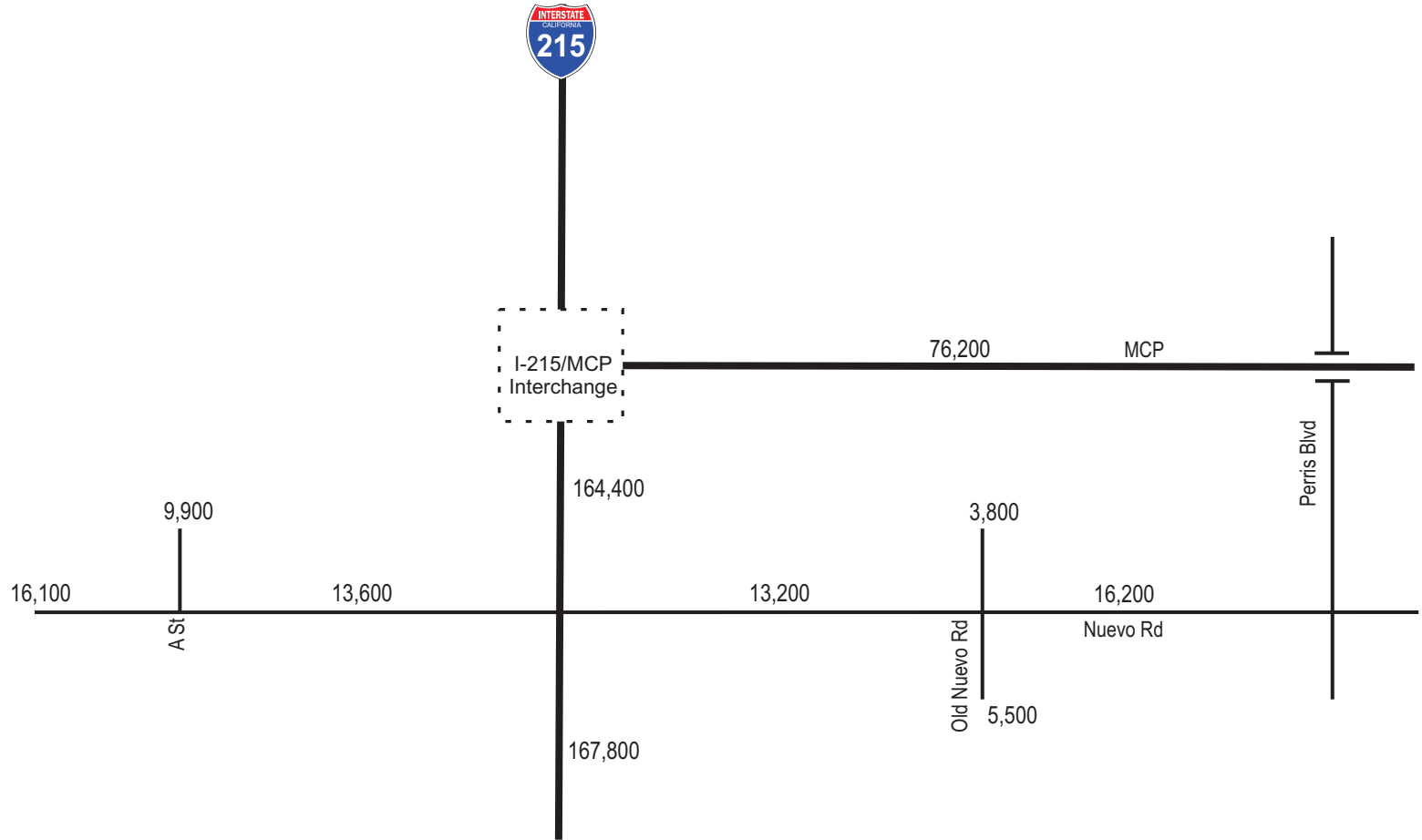

Not to Scale

Horizon Year (2040) ADT - Freeway and Street Segments MCP Area - Alternative 9 Modified

Figure 7-44h

Legend:

XX,XXX Average Daily Traffic



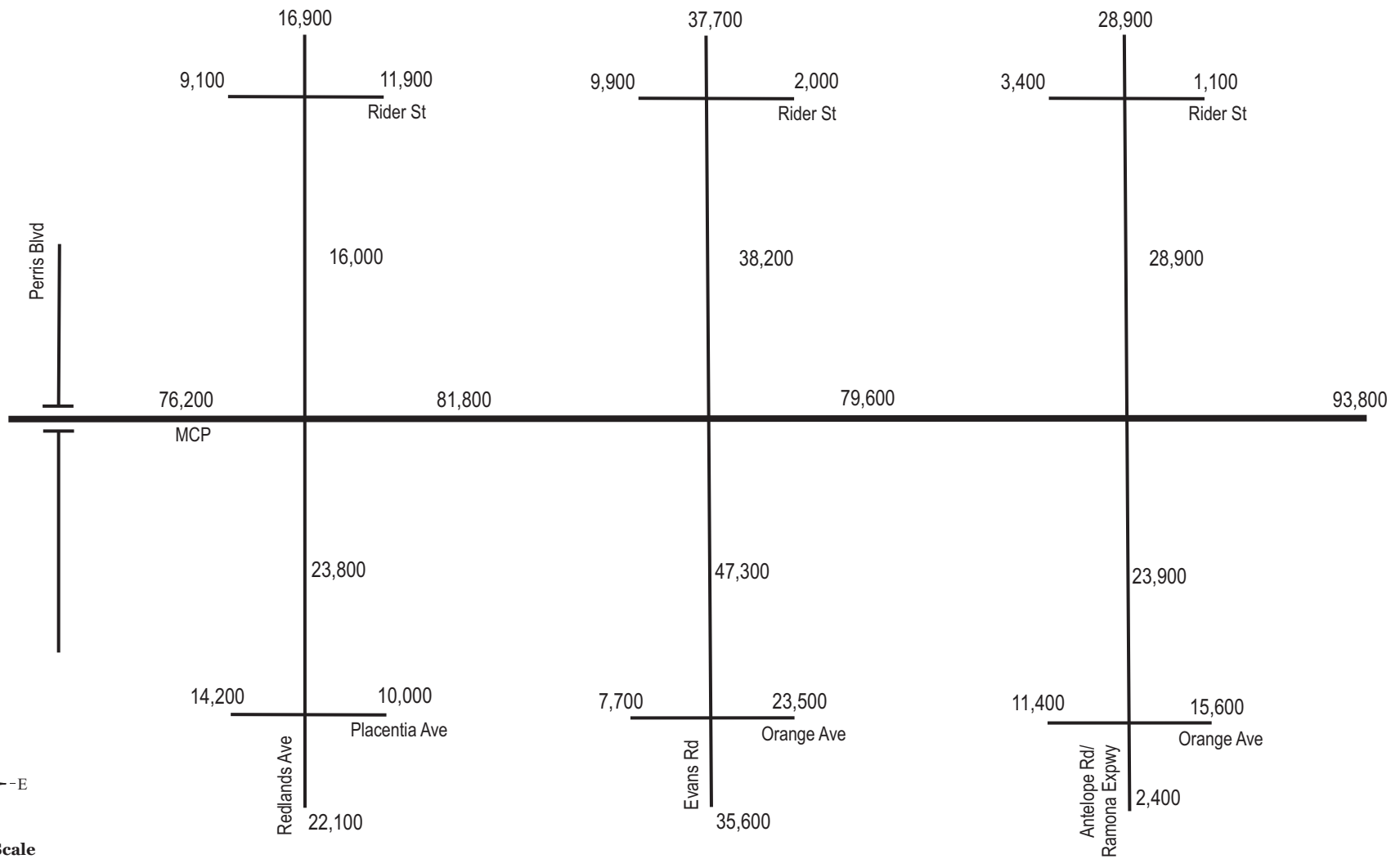

Horizon Year (2040) ADT - Freeway and Street Segments MCP Area - Alternative 9 Modified

Figure 7-44i

Legend:

XX,XXX Average Daily Traffic



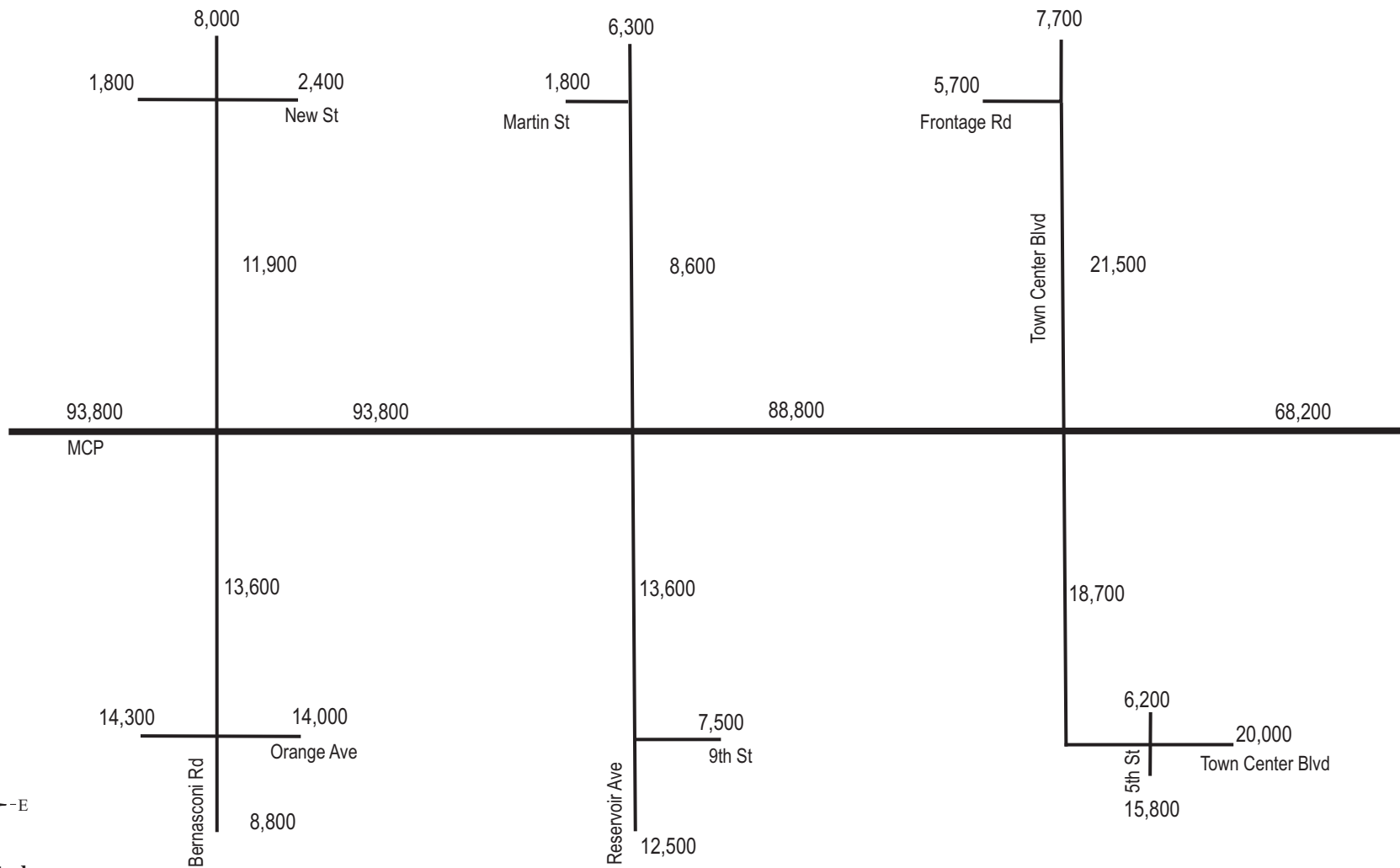

Horizon Year (2040) ADT - Freeway and Street Segments MCP Area - Alternative 9 Modified

Figure 7-44j

Legend:

XX,XXX Average Daily Traffic



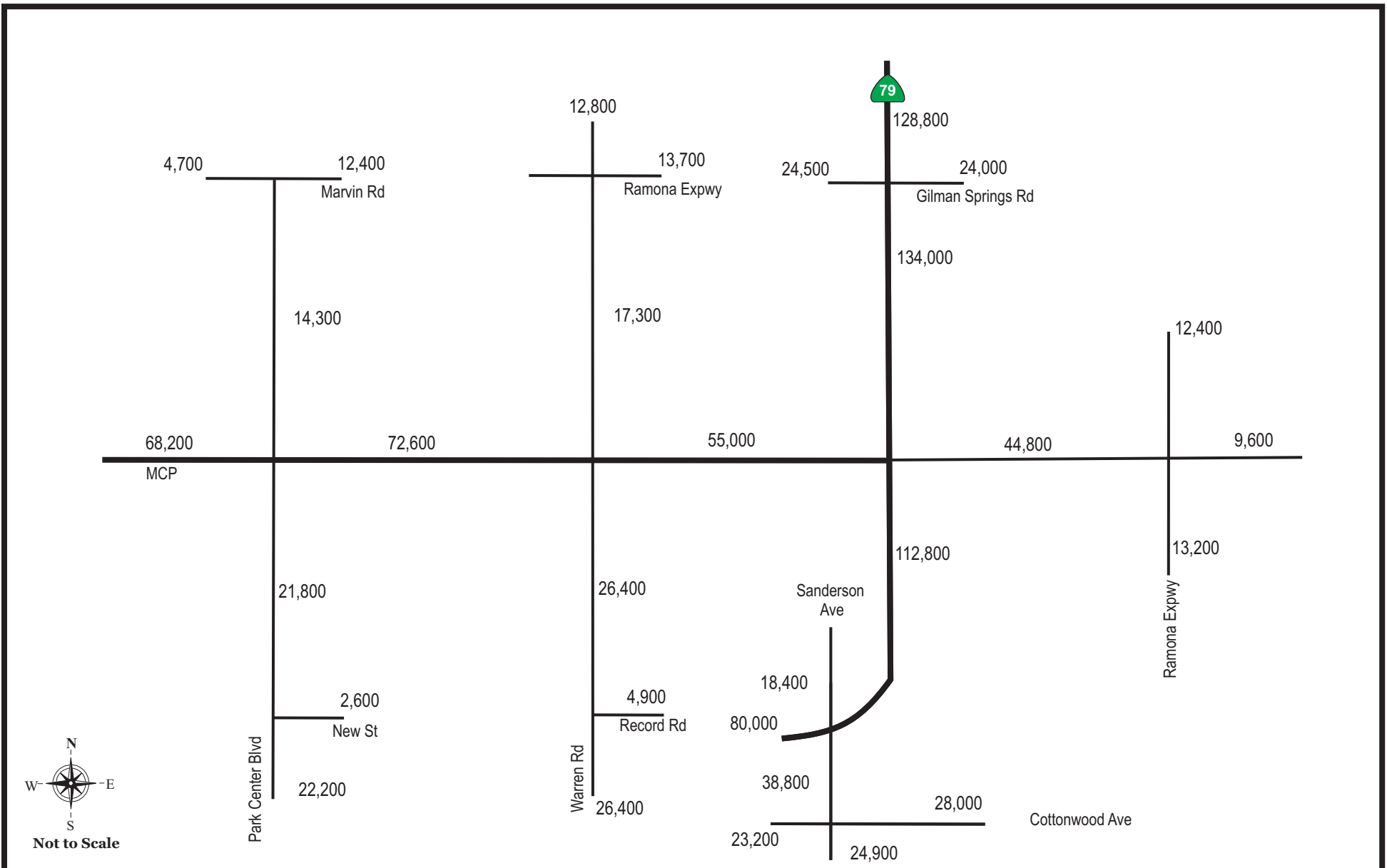

Horizon Year (2040) ADT - Freeway and Street Segments MCP Area - Alternative 9 Modified

Figure 7-44k

Legend:

XX,XXX Average Daily Traffic



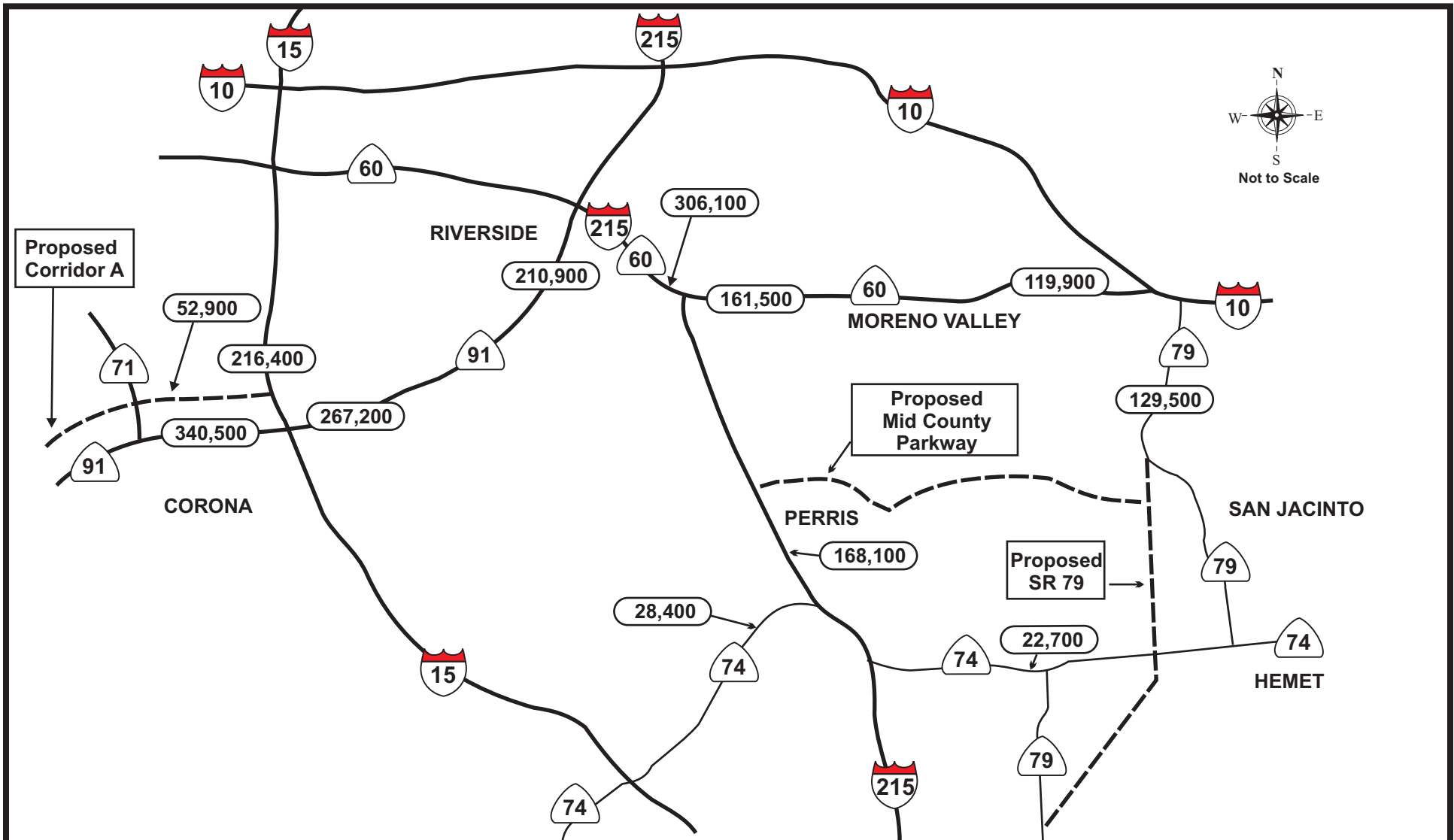

**Horizon Year (2040) ADT Freeway and Street Segments
Outside MCP Area - Alternative 9 Modified**

Figure 7-45

Legend

- Existing Limited Access Roadway
- Existing Arterial Roadway
- - - Proposed Limited Access Roadway
- (XXX,XXX) Average Daily Traffic



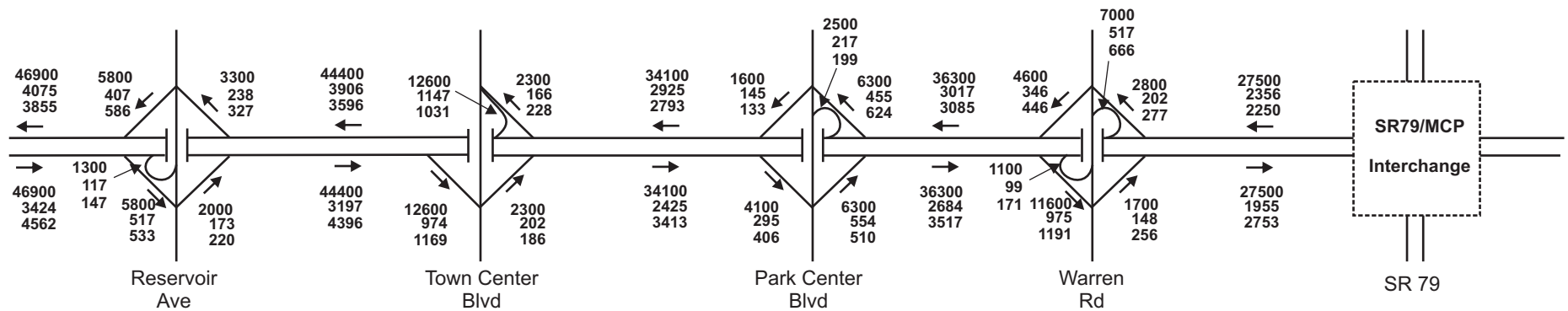
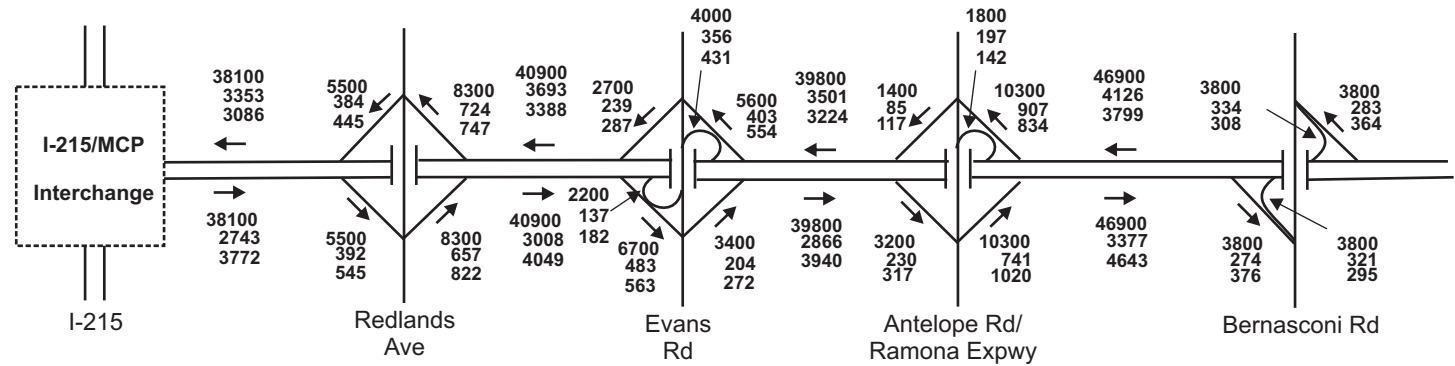

**Horizon Year (2040) Freeway and Ramp Traffic
Mid County Parkway - Alternative 9 Modified**

Figure 7-46

Legend

- XXXXXX Average Daily Traffic
- XXXX AM Peak Hour
- XXXX PM Peak Hour



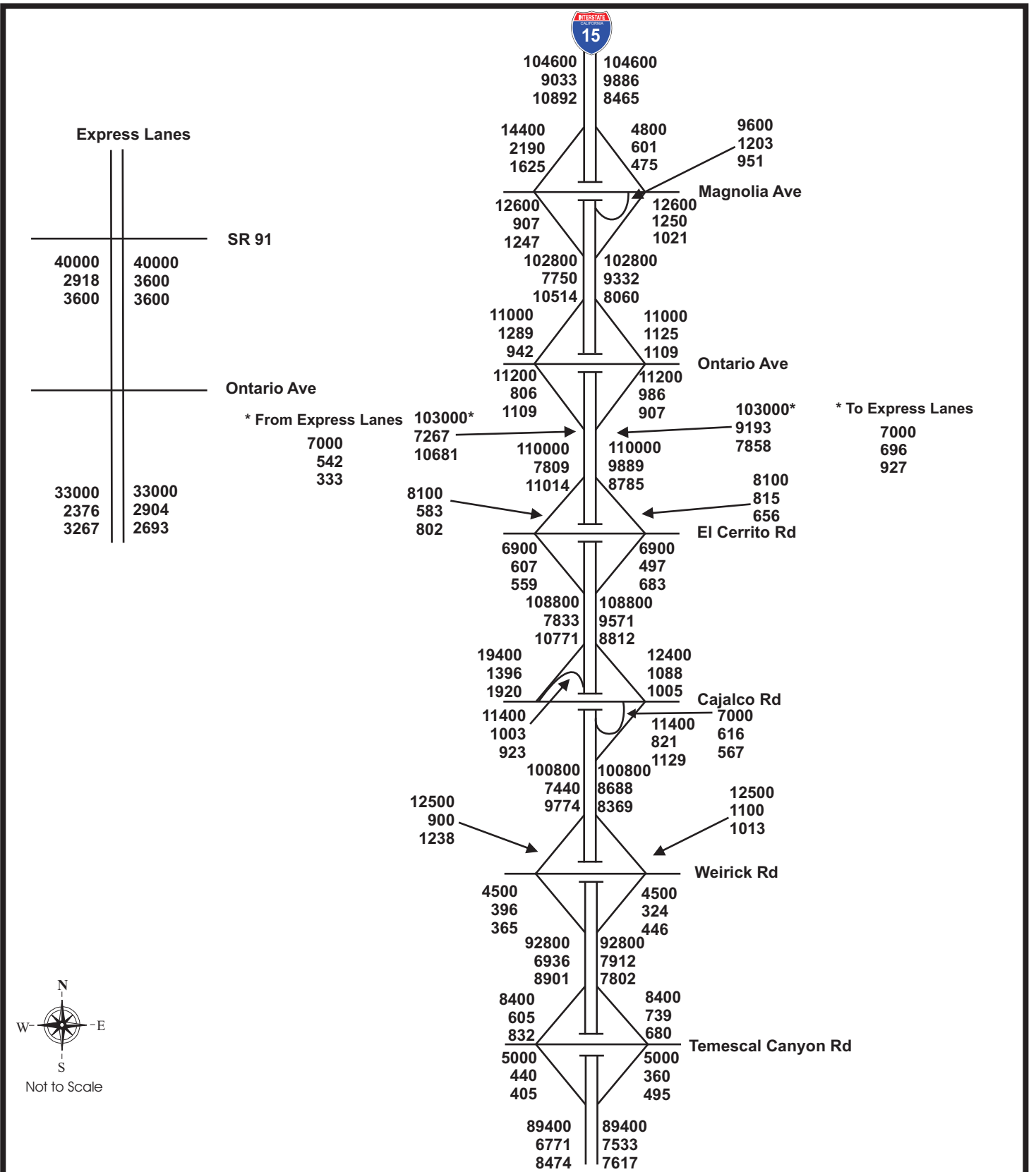

**Horizon Year (2040) Freeway and Ramp Traffic
Interstate 15 - Alternative 9 Modified**

Figure 7-47

Legend

XXXXX ADT
 XXXX AM Peak Hour
 XXXX PM Peak Hour



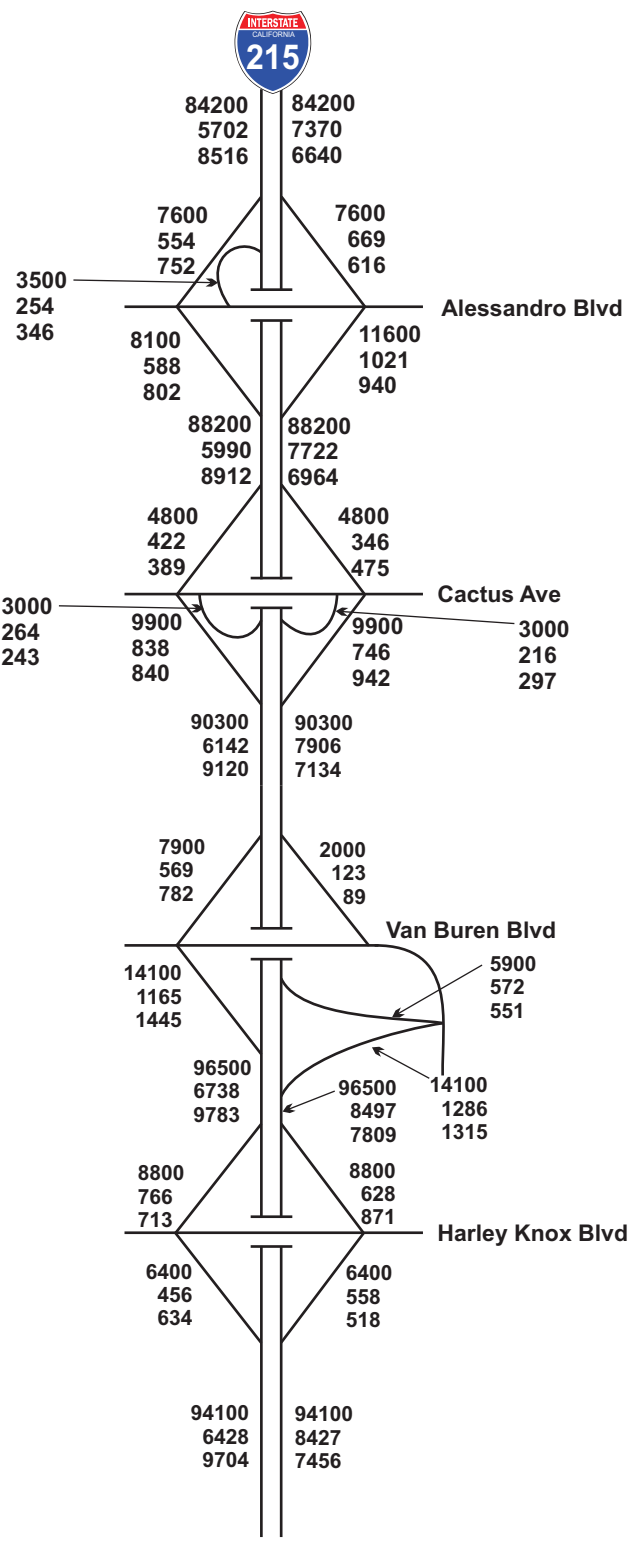
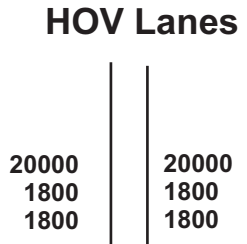

**Horizon Year (2040)
Freeway and Ramp Traffic
Interstate 215 - Alternative 9 Modified**

Figure 7-48a

Legend

XXXXX Average Daily Traffic
 XXX AM Peak Hour Traffic
 XXX PM Peak Hour Traffic



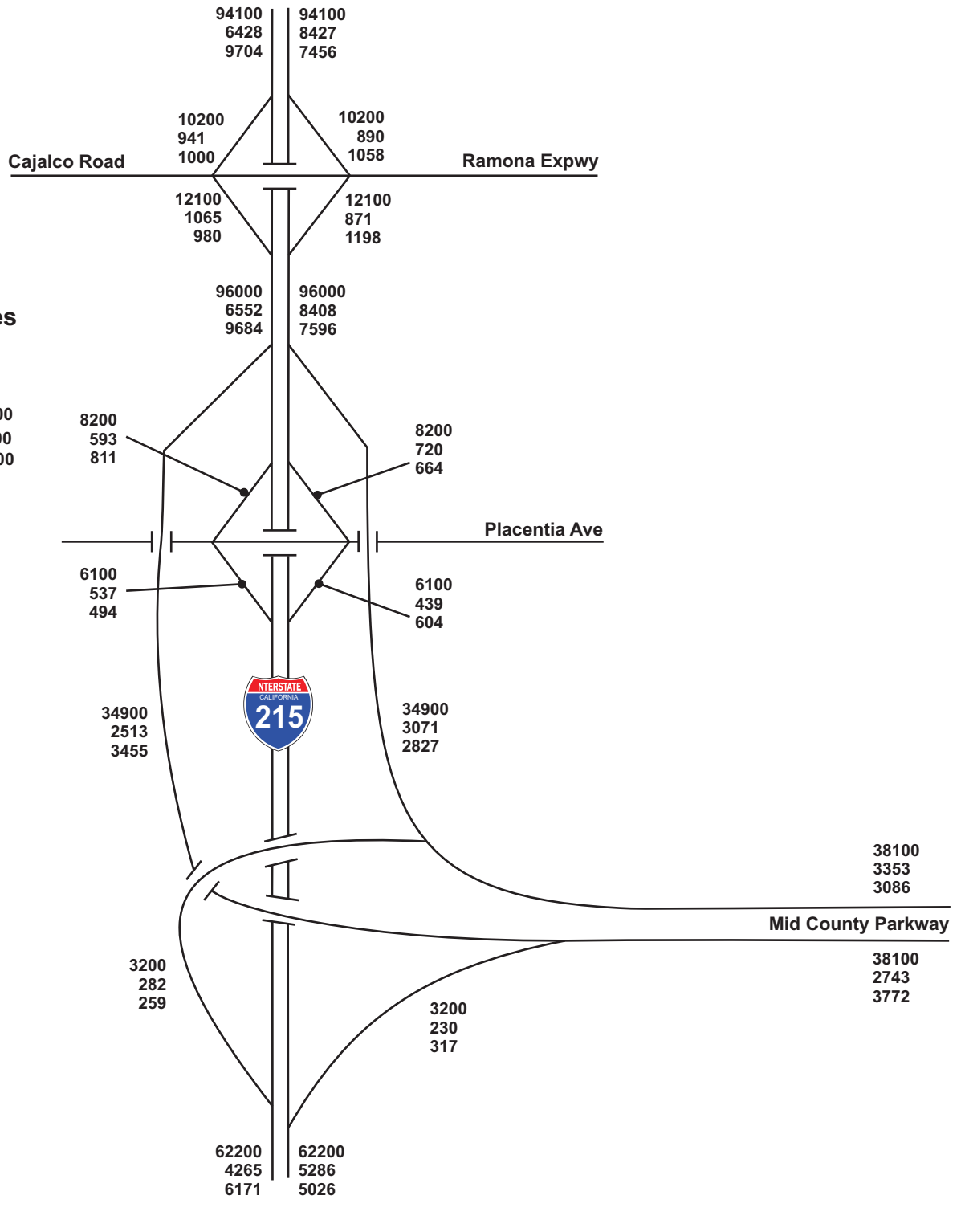

**Horizon Year (2040)
Freeway and Ramp Traffic
Interstate 215 - Alternative 9 Modified**

Figure 7-48b

Legend

- XXXXX Average Daily Traffic
- XXX AM Peak Hour Traffic
- XXX PM Peak Hour Traffic



**HOV Lanes
(North of Nuevo Road Only)**

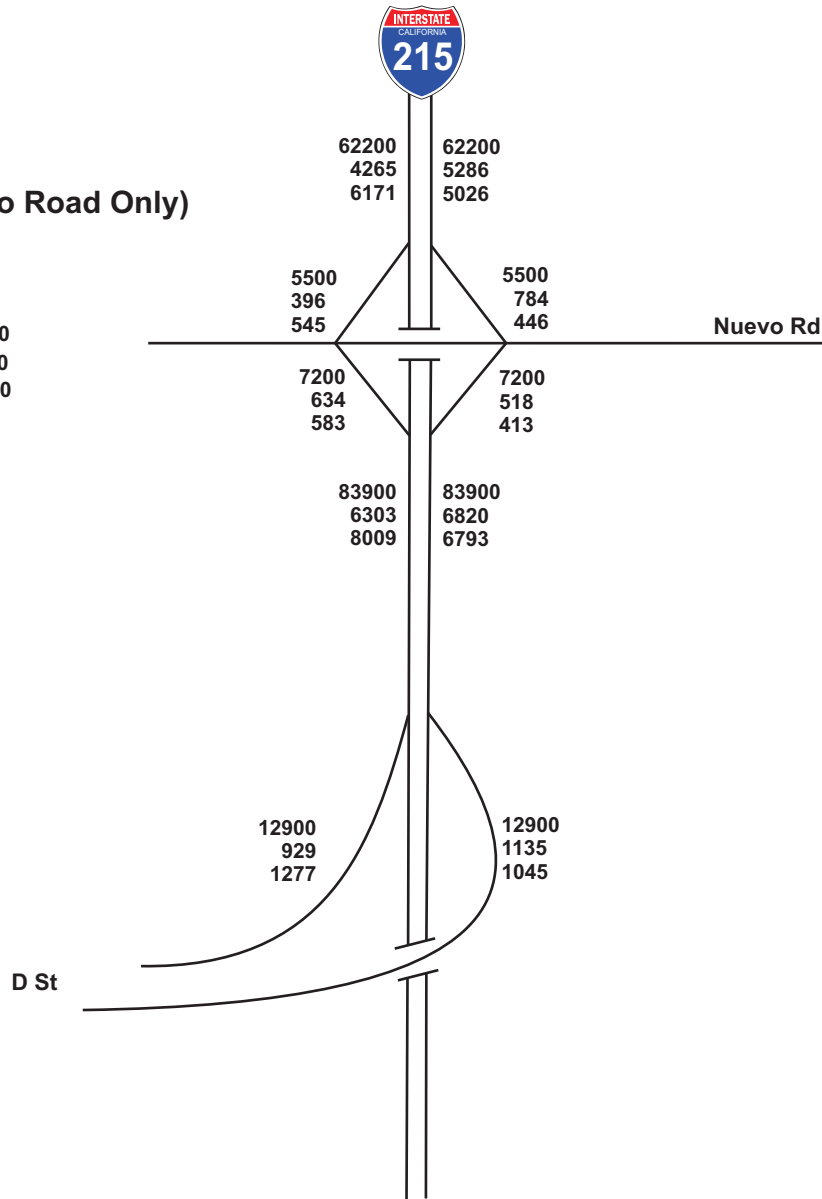
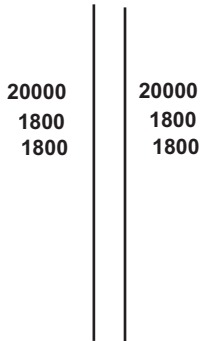

**Horizon Year (2040)
Freeway and Ramp Traffic
Interstate 215 - Alternative 9 Modified**

Figure 7-48c

Legend

- XXXXX Average Daily Traffic
- XXX AM Peak Hour Traffic
- XXX PM Peak Hour Traffic



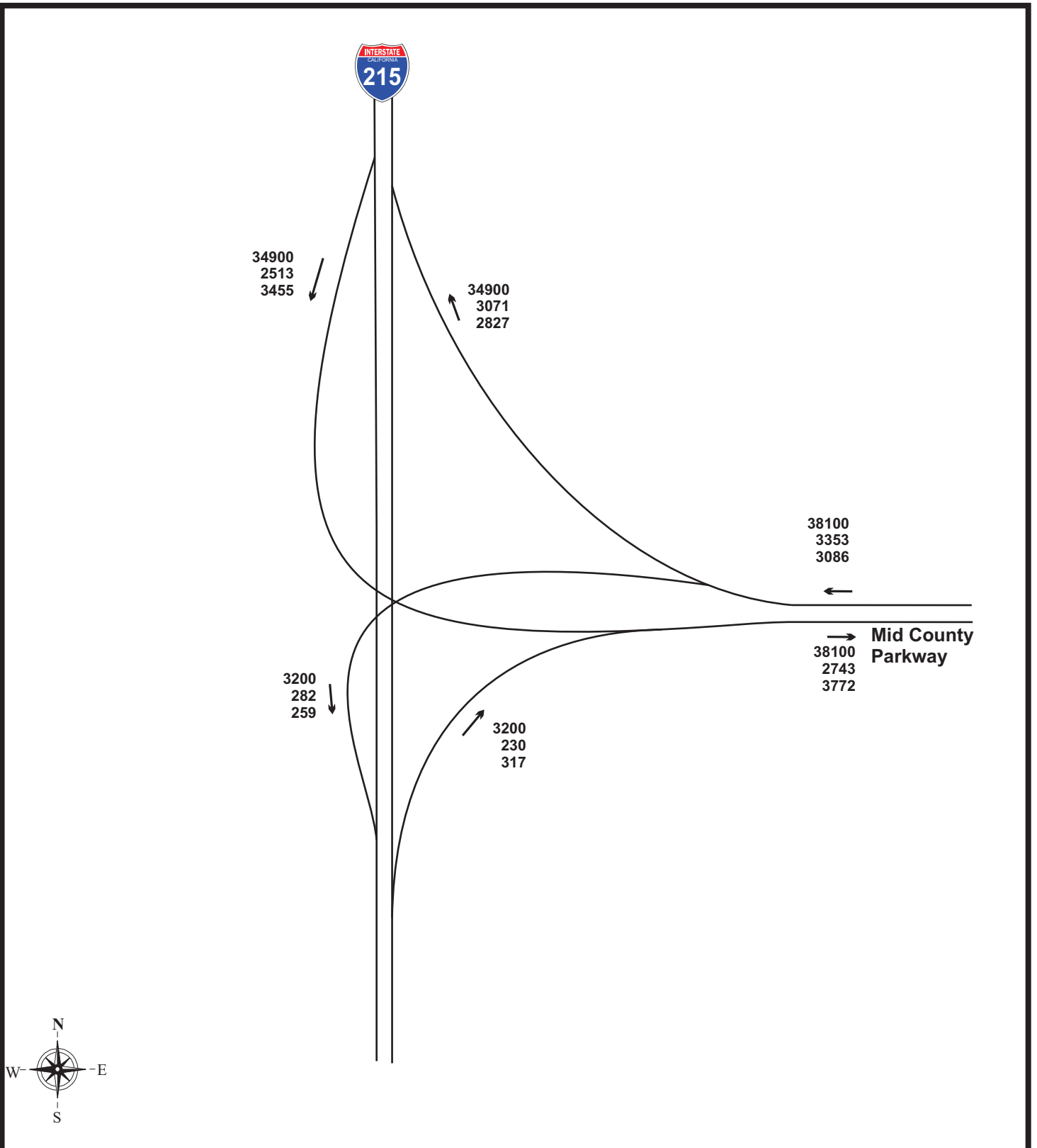

Horizon Year (2040) MCP/I-215 Interchange Area Traffic - Alternative 9 Modified

Figure 7-49



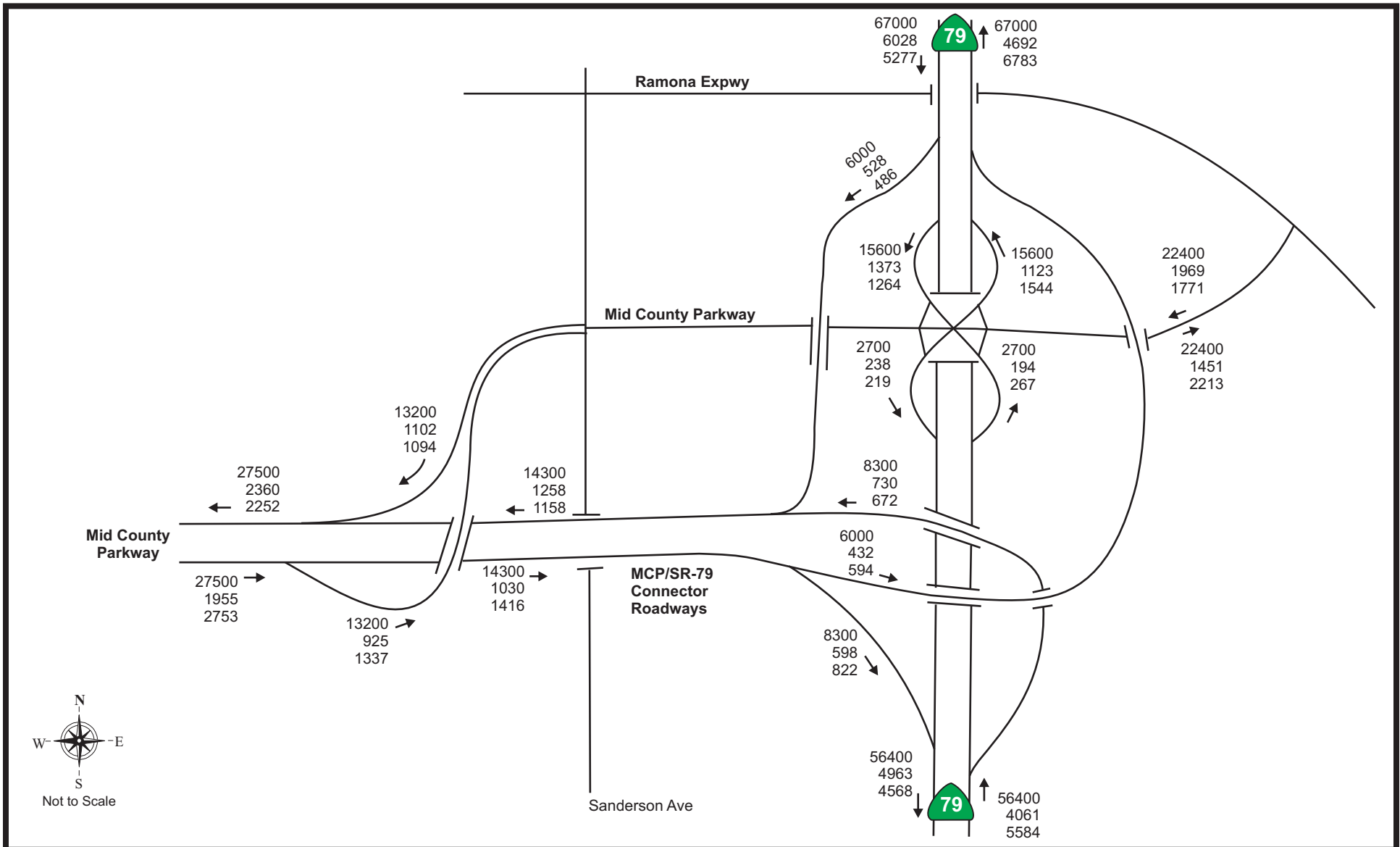

Horizon Year (2040) MCP/SR-79 Interchange Area Traffic - Alternative 9 Modified

Figure 7-50

Legend

- xxxxx Average Daily Traffic
- xxxx AM Peak Hour
- xxxx PM Peak Hour



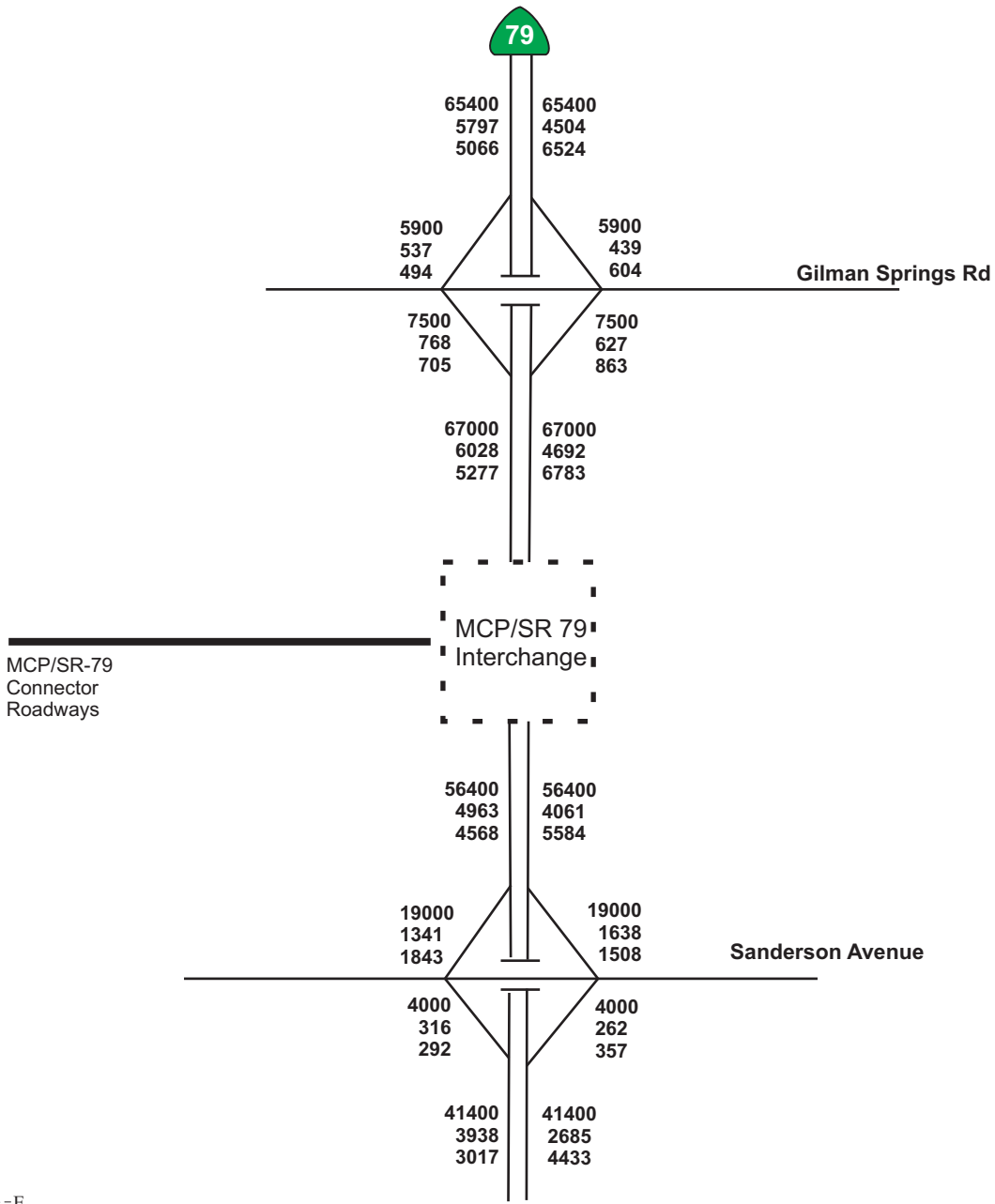

Not to Scale

**Horizon Year (2040)
Freeway and Ramp Traffic
SR 79 - Alternative 9**

Figure 7-50b

Legend

→ Direction of Travel

X : Number of Lanes (Mixed Flow)



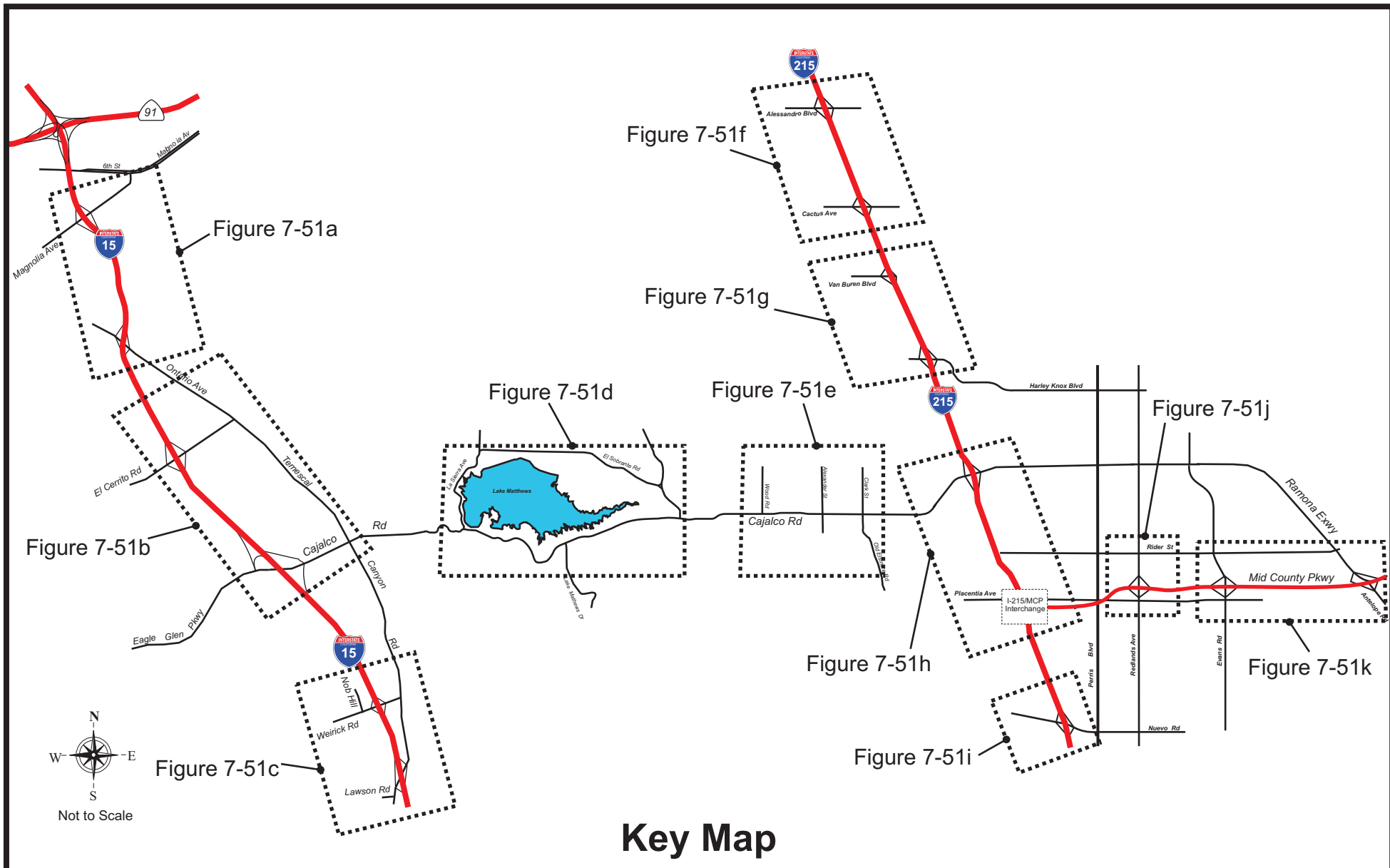

**Horizon Year (2040) AM/PM Peak Hour Traffic - Intersections
Alternative 9**

Figure 7-51

Legend:

 Figure Areas



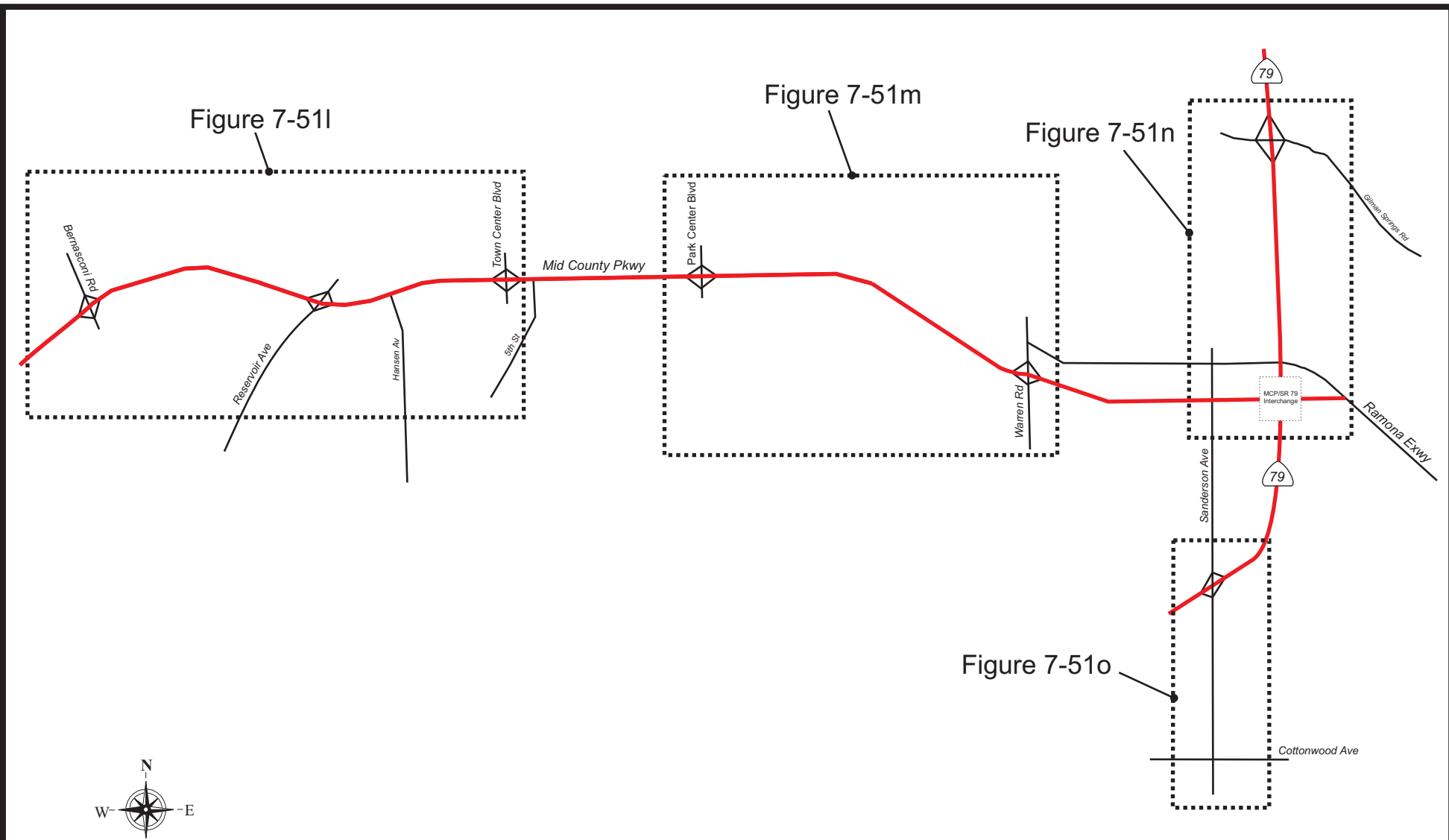

Key Map

**Horizon Year (2040) AM/PM Peak Hour Traffic - Intersections
Alternative 9**

Figure 7-51 (cont.)

Legend:

 Figure Areas



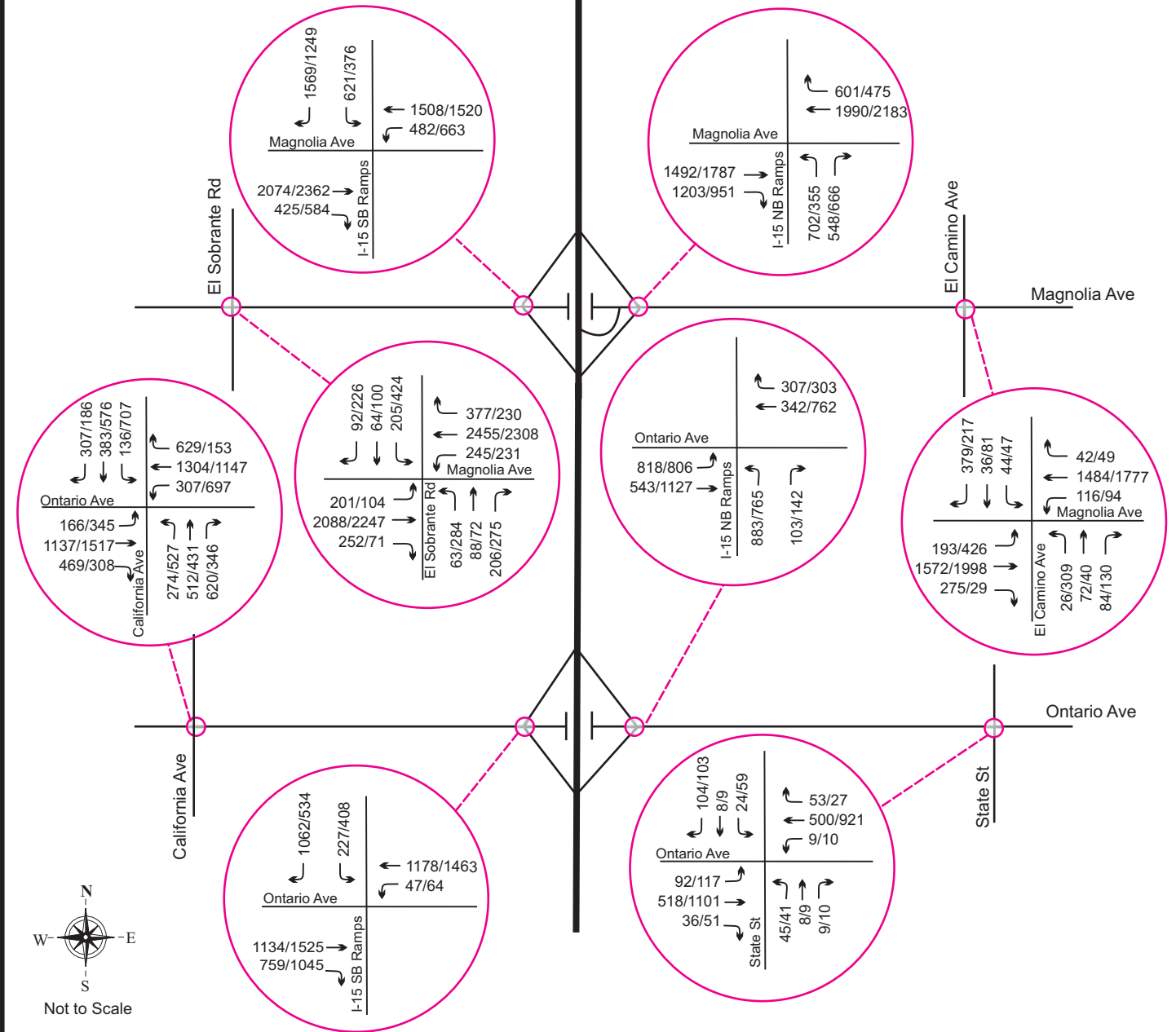

Horizon Year (2040) AM/PM Peak Hour Traffic Intersections - Alternative 9 Modified

Figure 7-51a

XXX/XXX AM/PM Peak Hour



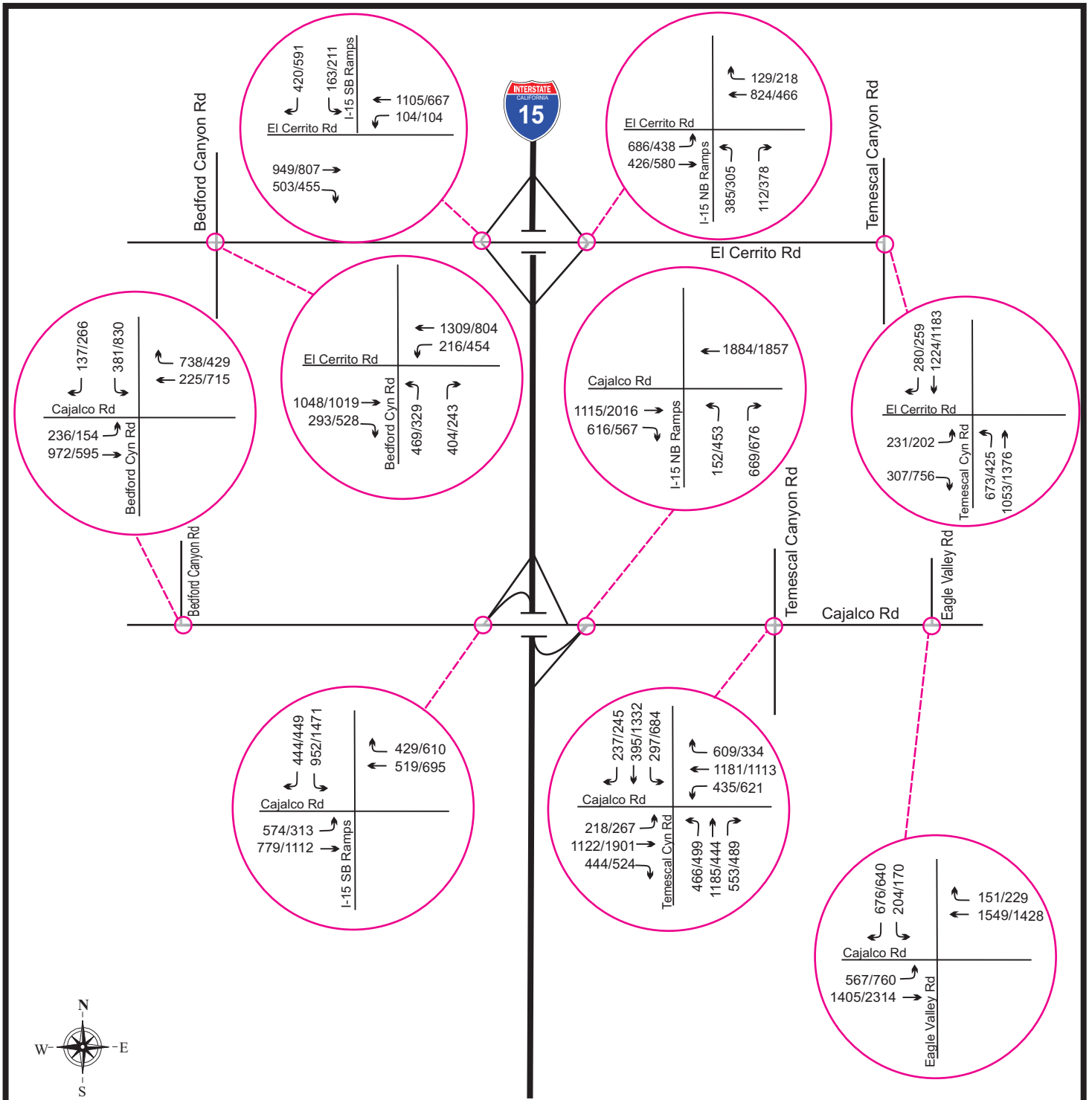

Horizon Year (2040) AM/PM Peak Hour Traffic Intersections - Alternative 9 Modified

Figure 7-51b

XXX/XXX AM/PM Peak Hour



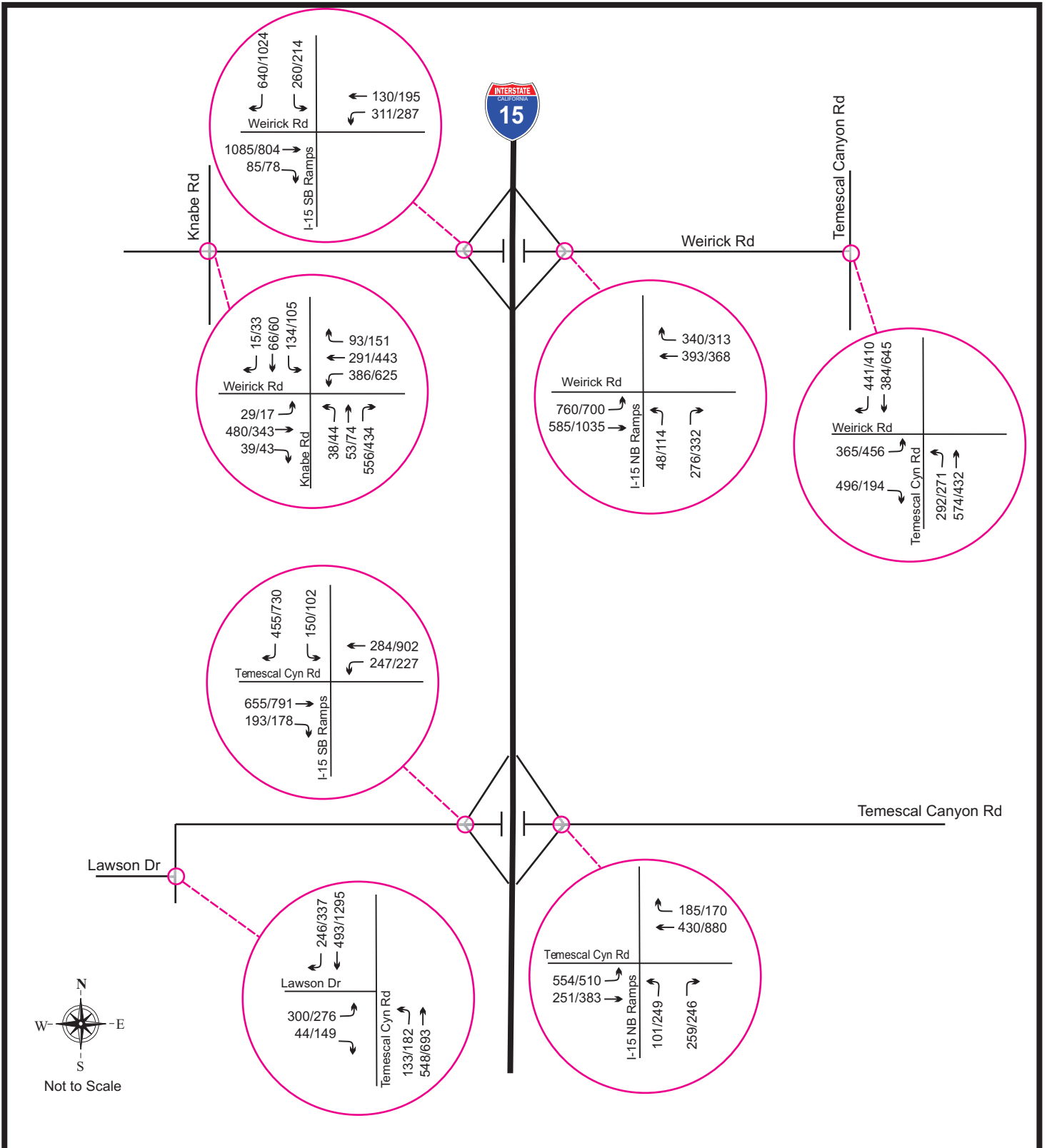

Horizon Year (2040) AM/PM Peak Hour Traffic Intersections - Alternative 9 Modified

Figure 7-51c

XXX/XXX AM/PM Peak Hour



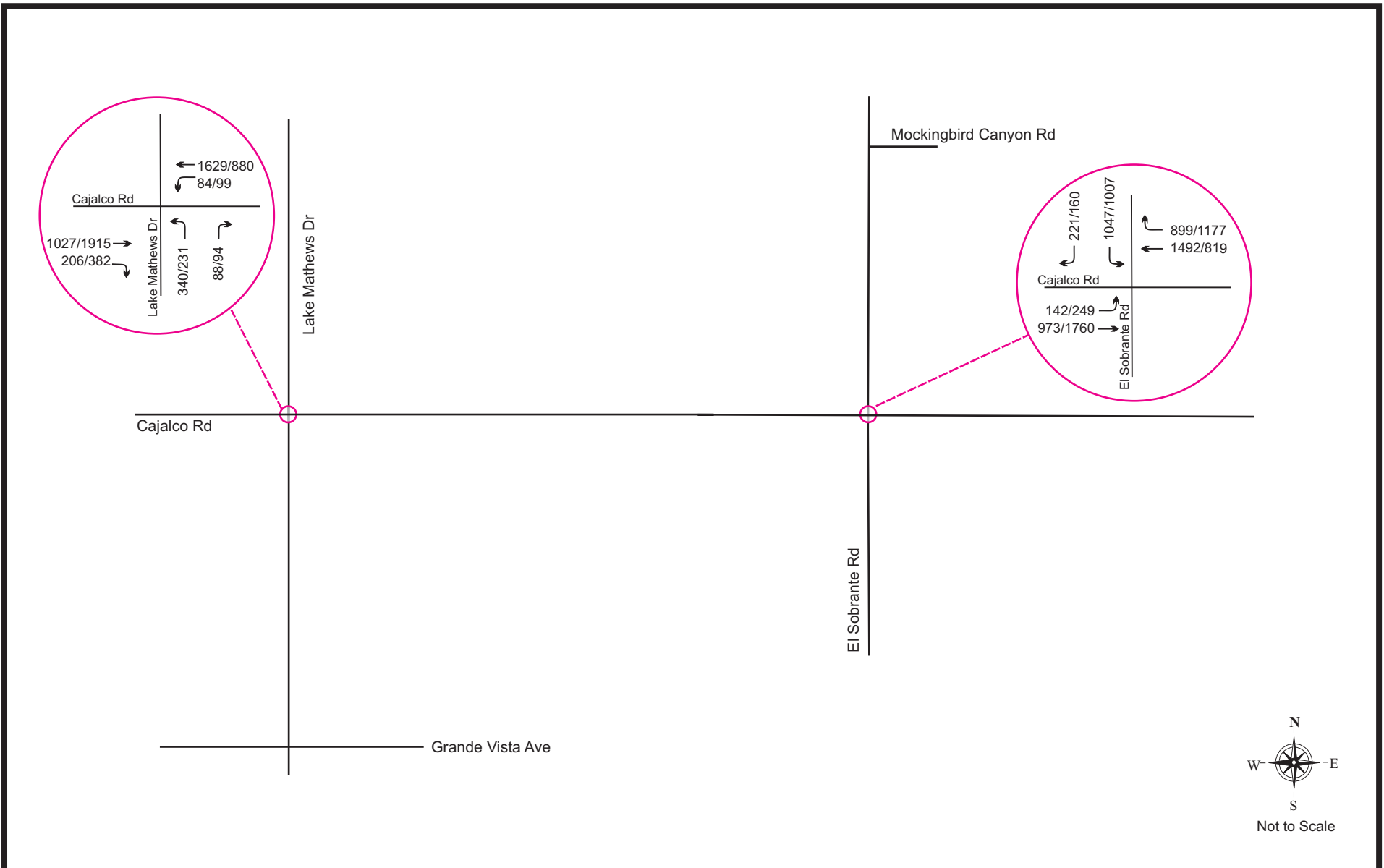

**Horizon Year (2040) AM/PM Peak Hour Traffic Intersections
Alternative 9 Modified**

Figure 7-51d

XXX/XXX AM/PM Peak Hour



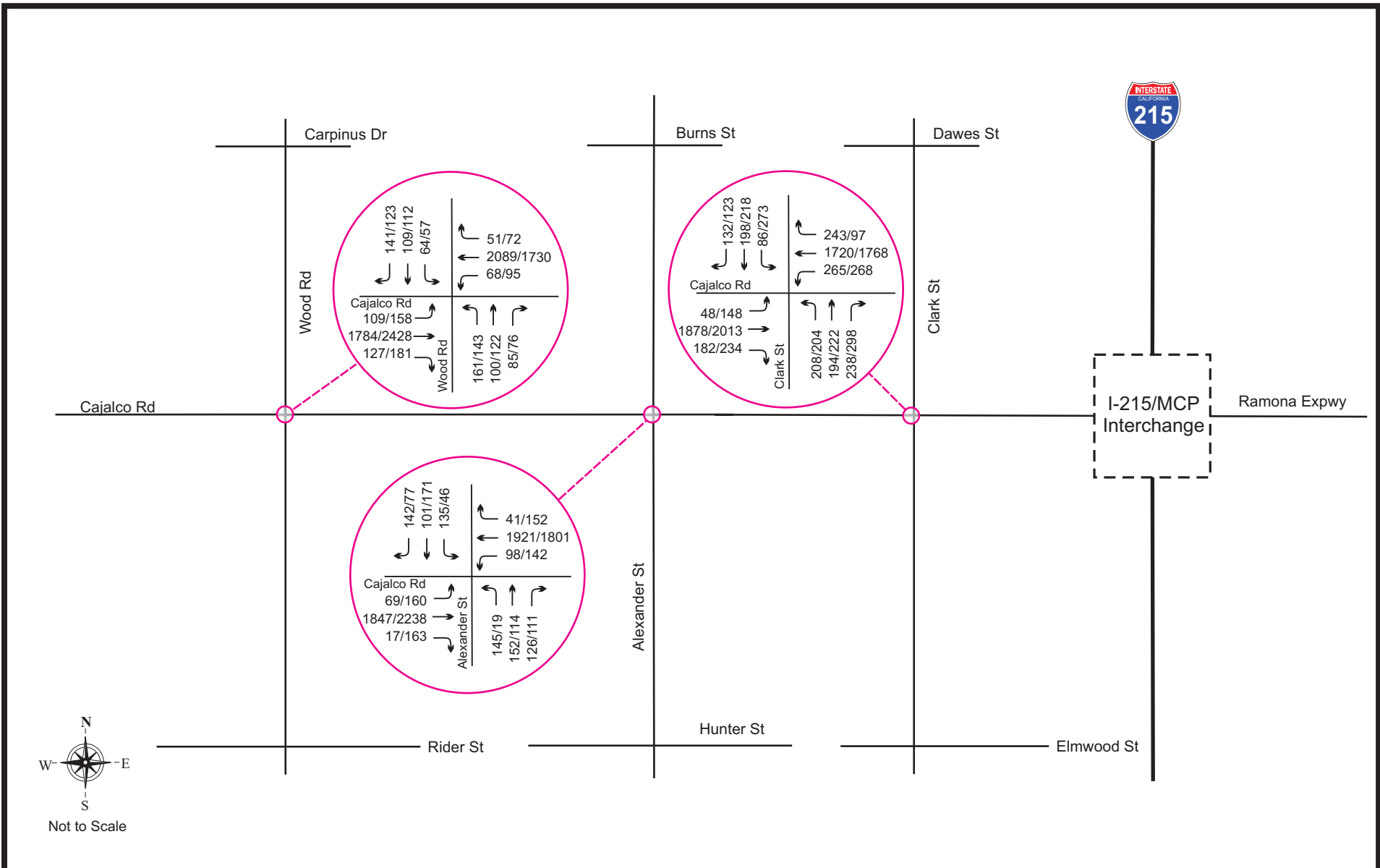

**Horizon Year (2040) AM/PM Peak Hour Traffic Intersections
Alternative 9 Modified**

Figure 7-51e

XXX/XXX AM/PM Peak Hour



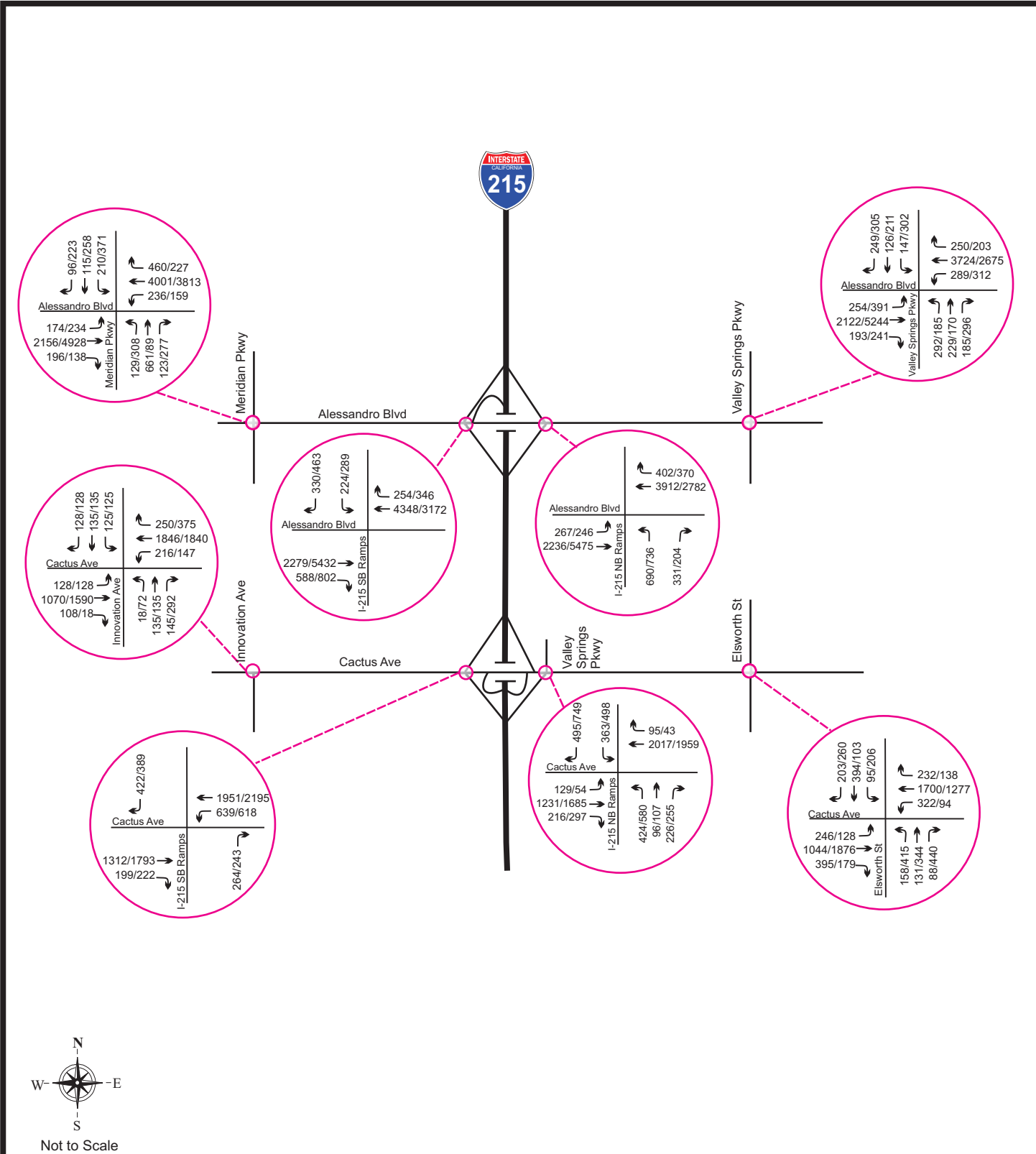

Not to Scale

Horizon Year (2040) AM/PM Peak Hour Traffic Intersections - Alternative 9 Modified

Figure 7-51f

XXX/XXX AM/PM Peak Hour



VRPA TECHNOLOGIES, INC.

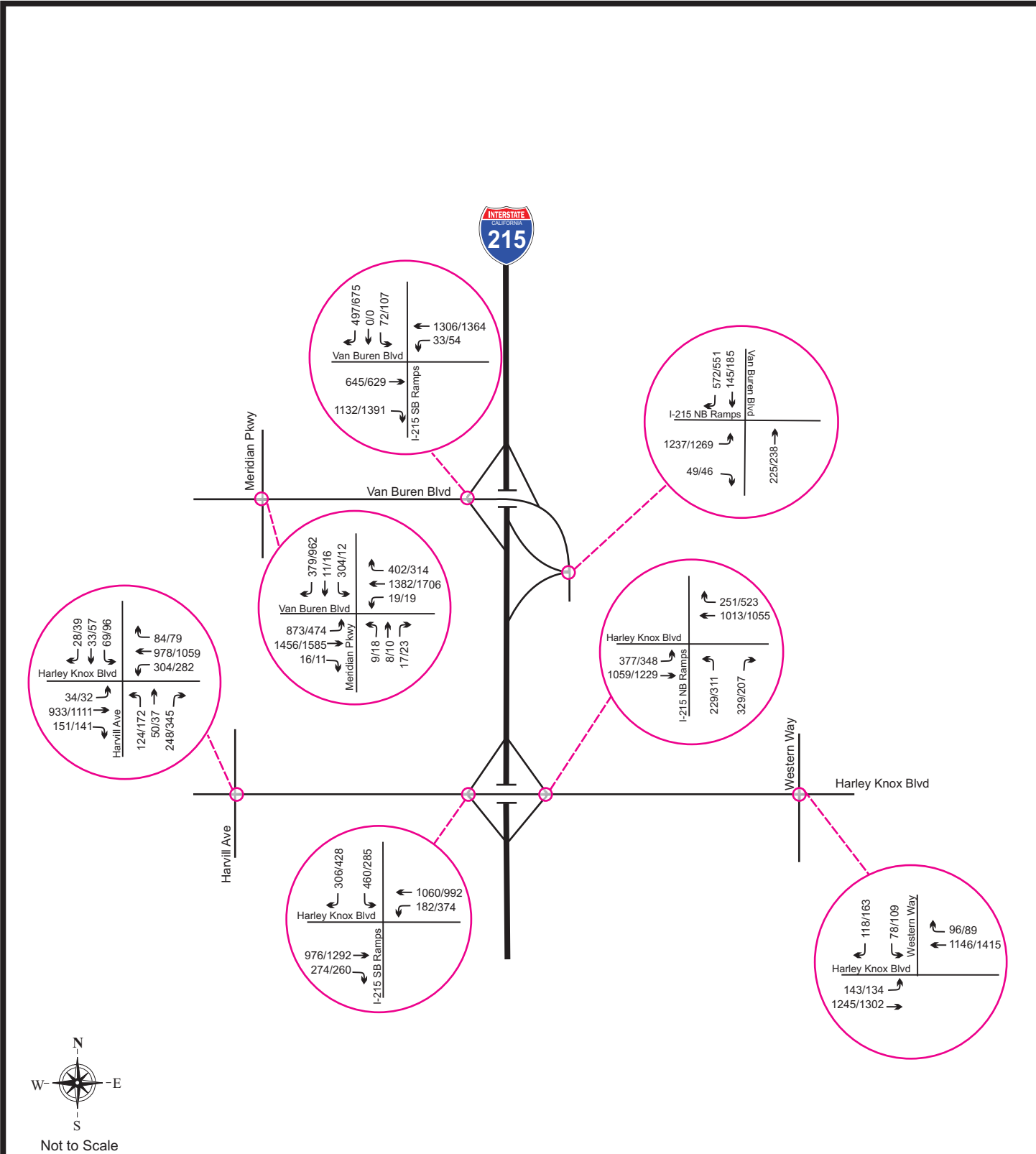

Horizon Year (2040) AM/PM Peak Hour Traffic Intersections - Alternative 9 Modified

Figure 7-51g

XXX/XXX AM/PM Peak Hour



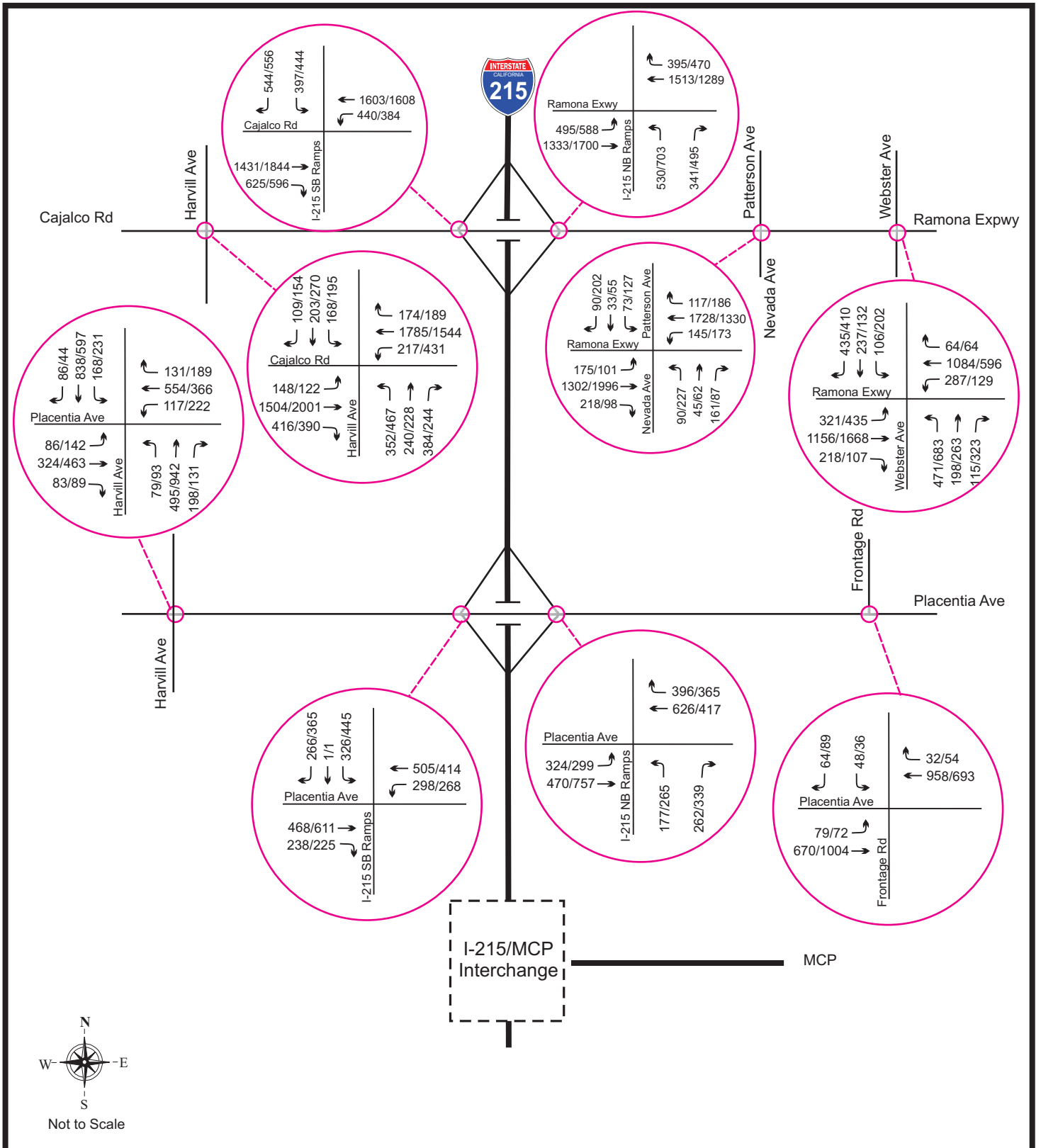

Horizon Year (2040) AM/PM Peak Hour Traffic Intersections - Alternative 9 Modified

Figure 7-51h

XXX/XXX AM/PM Peak Hour



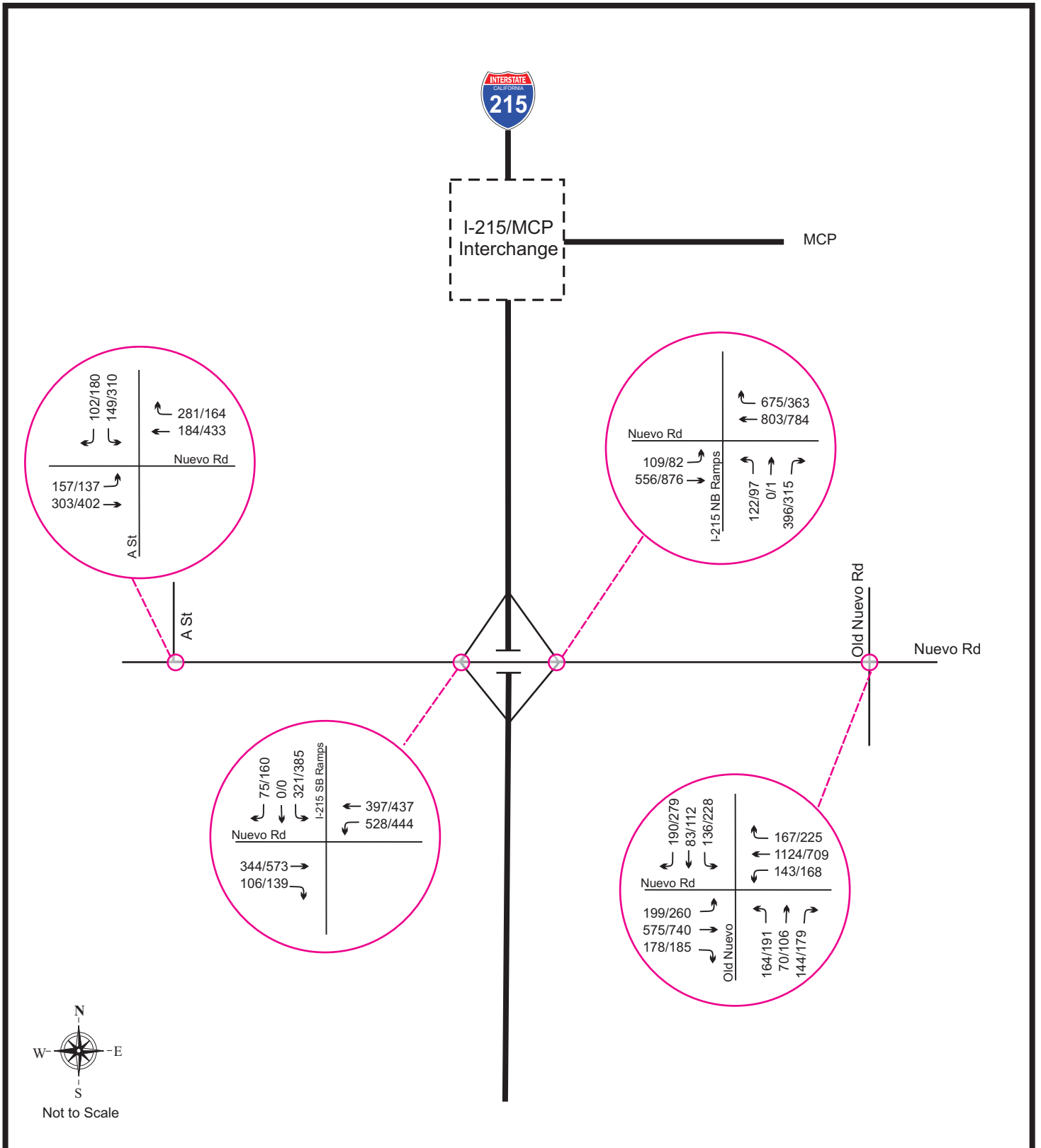

Horizon Year (2040) AM/PM Peak Hour Traffic Intersections - Alternative 9 Modified

Figure 7-51i

XXX/XXX AM/PM Peak Hour



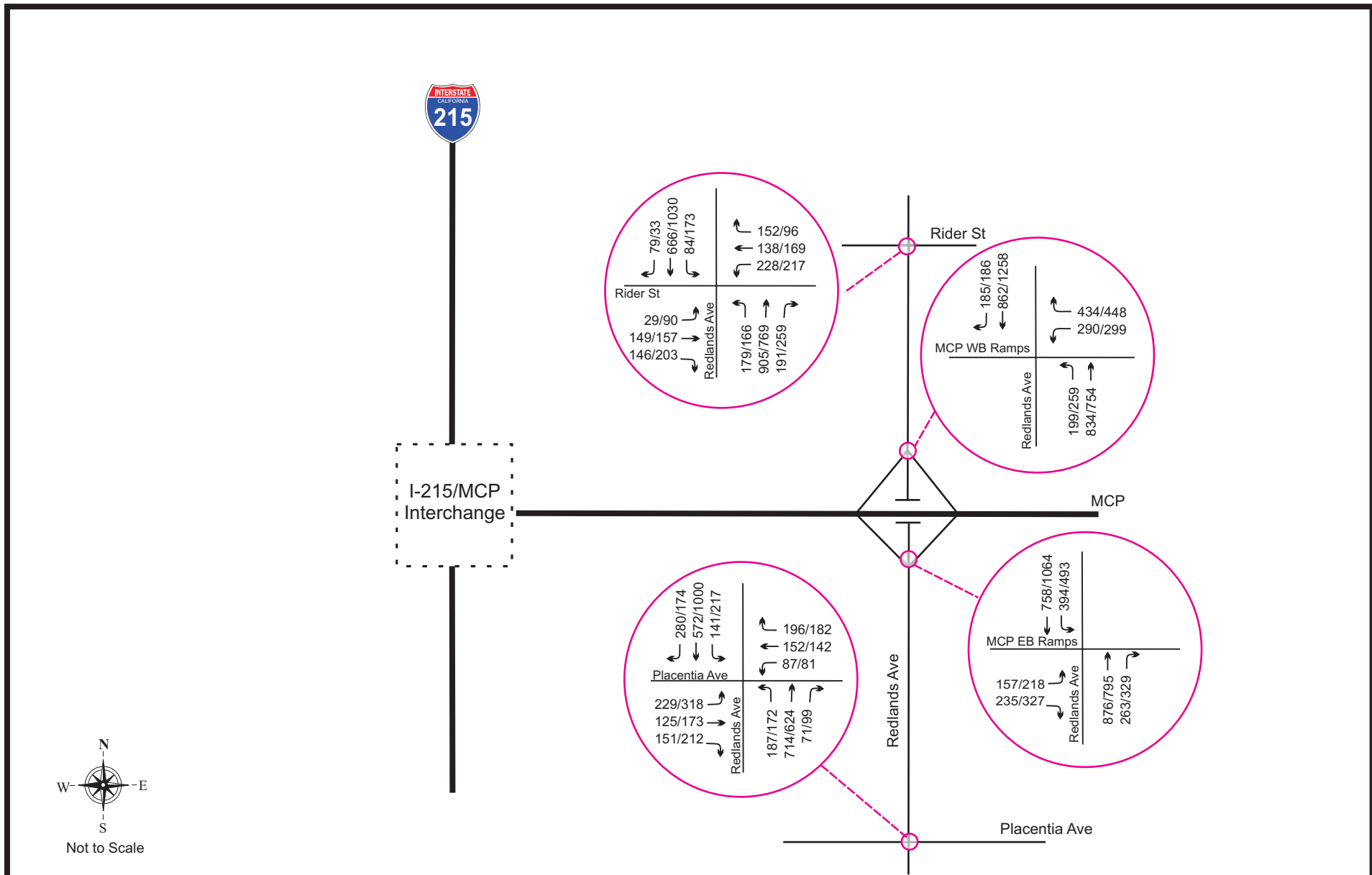

**Horizon Year (2040) AM/PM Peak Hour Traffic Intersections
Alternative 9 Modified**

Figure 7-51j

XXX/XXX AM/PM Peak Hour



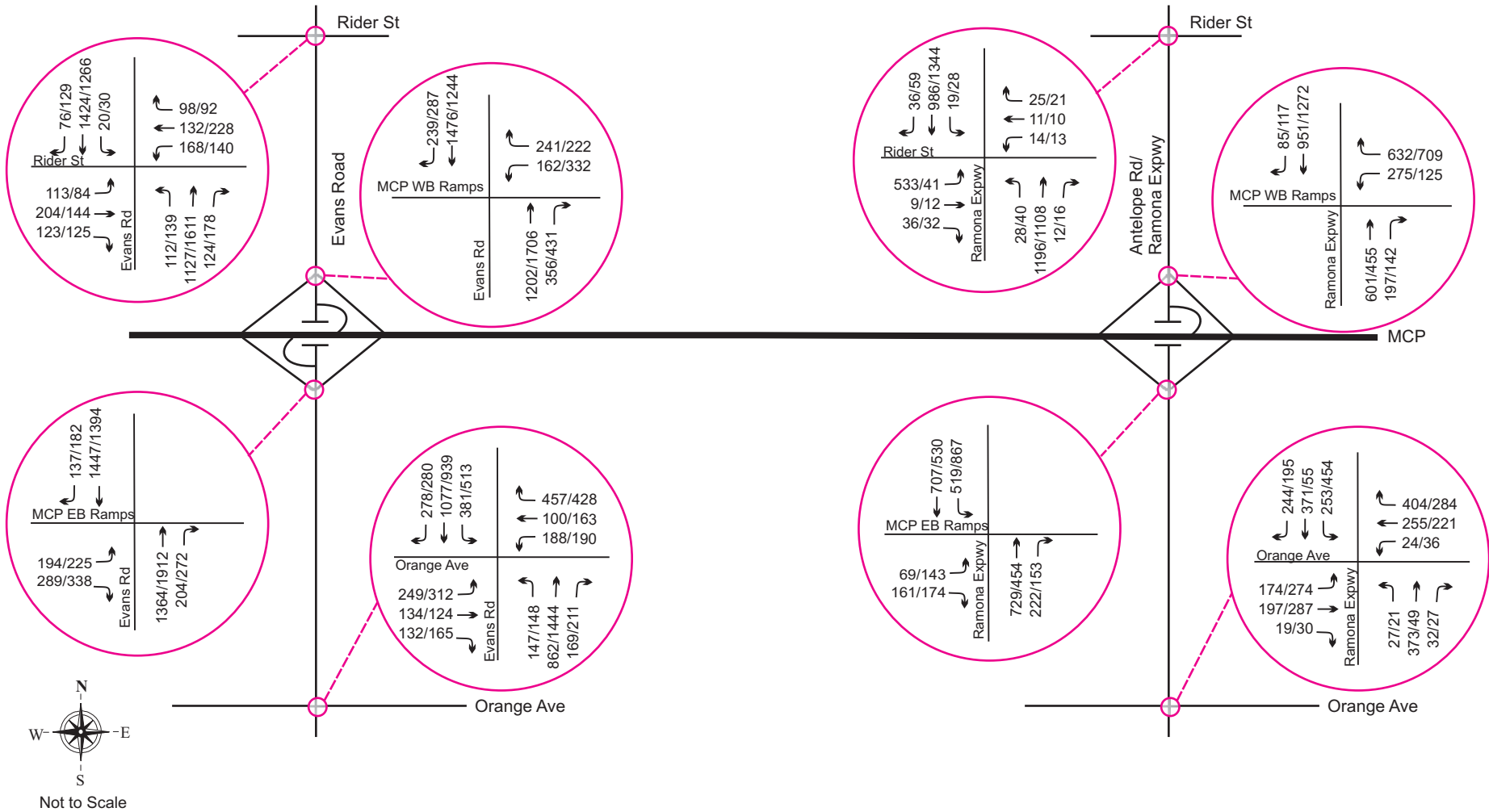

**Horizon Year (2040) AM/PM Peak Hour Traffic Intersections
Alternative 9 Modified**

Figure 7-51k

XXX/XXX AM/PM Peak Hour



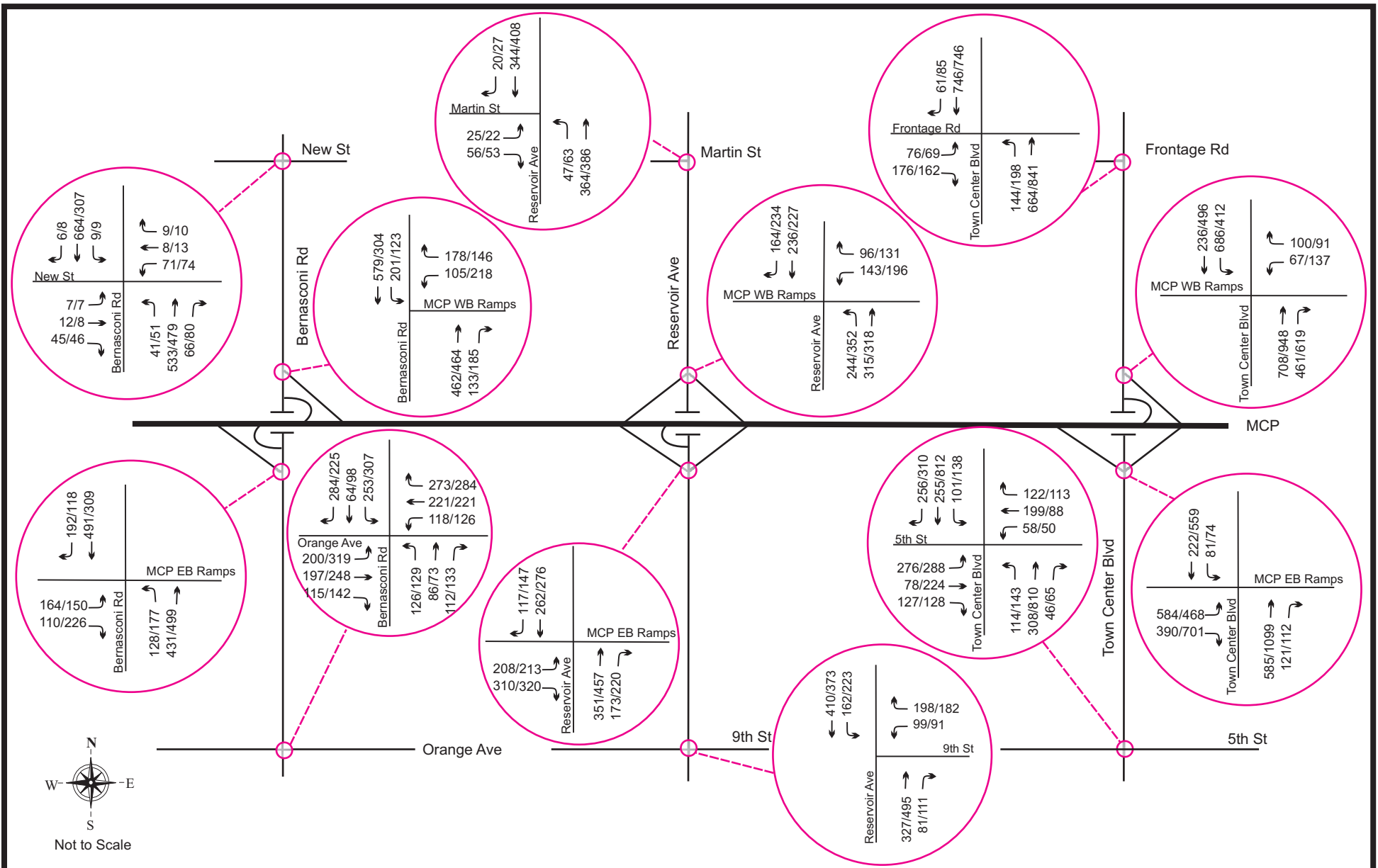

**Horizon Year (2040) AM/PM Peak Hour Traffic Intersections
Alternative 9 Modified**

Figure 7-51I

XXX/XXX AM/PM Peak Hour



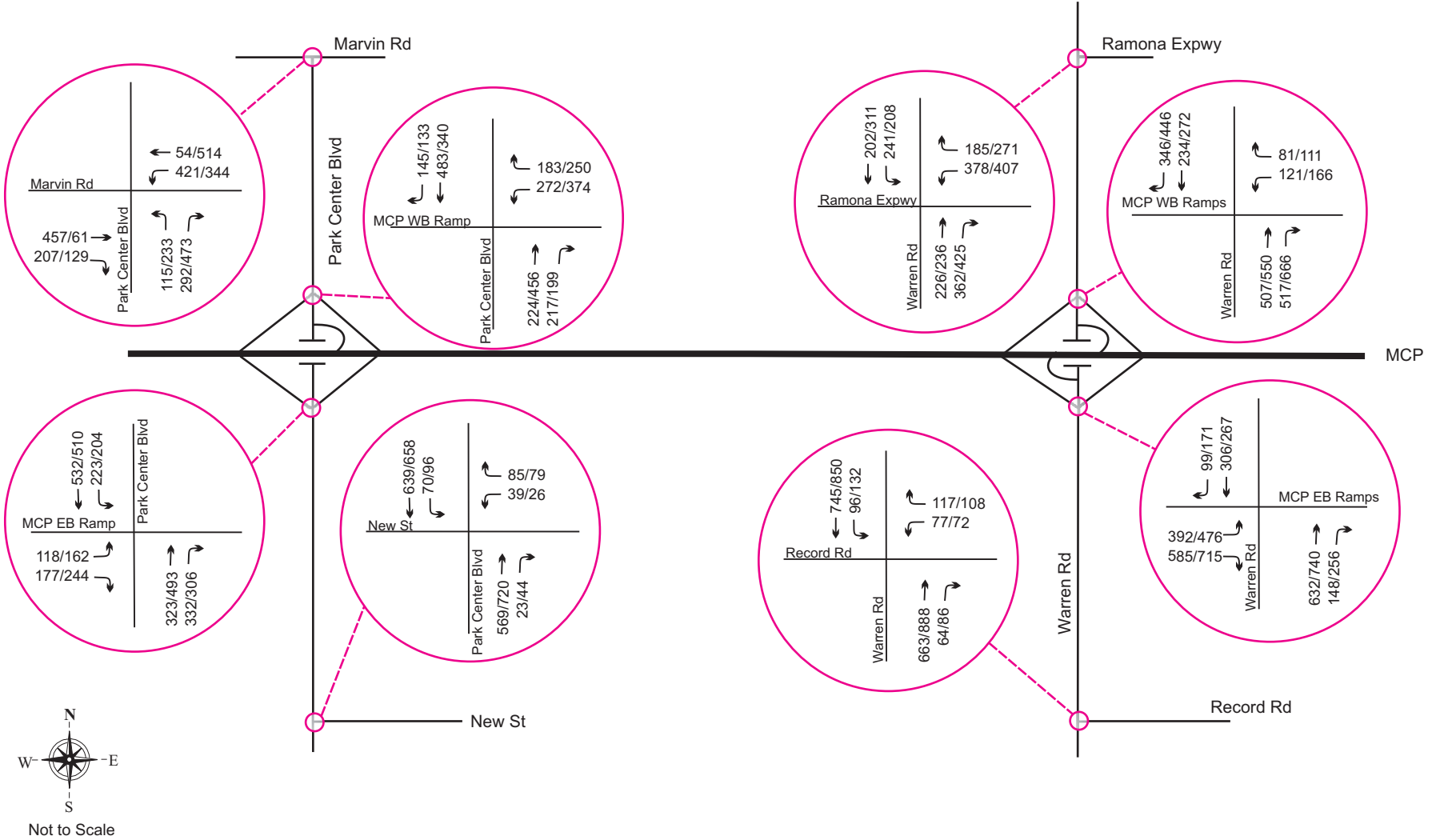

**Horizon Year (2040) AM/PM Peak Hour Traffic Intersections
Alternative 9 Modified**

Figure 7-51m

XXX/XXX AM/PM Peak Hour



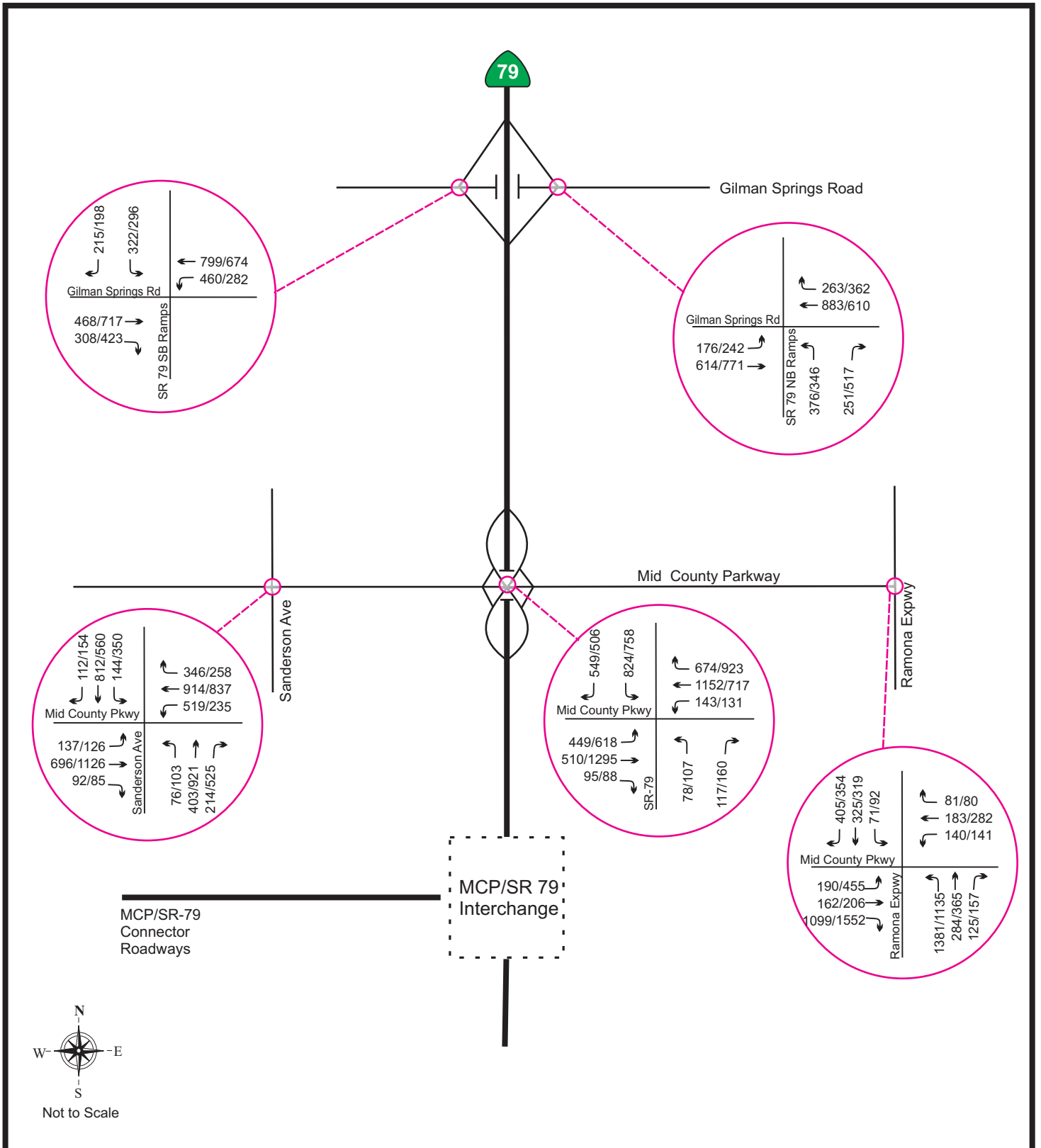

Horizon Year (2040) AM/PM Peak Hour Traffic Intersections - Alternative 9 Modified

Figure 7-51n

XXX/XXX AM/PM Peak Hour



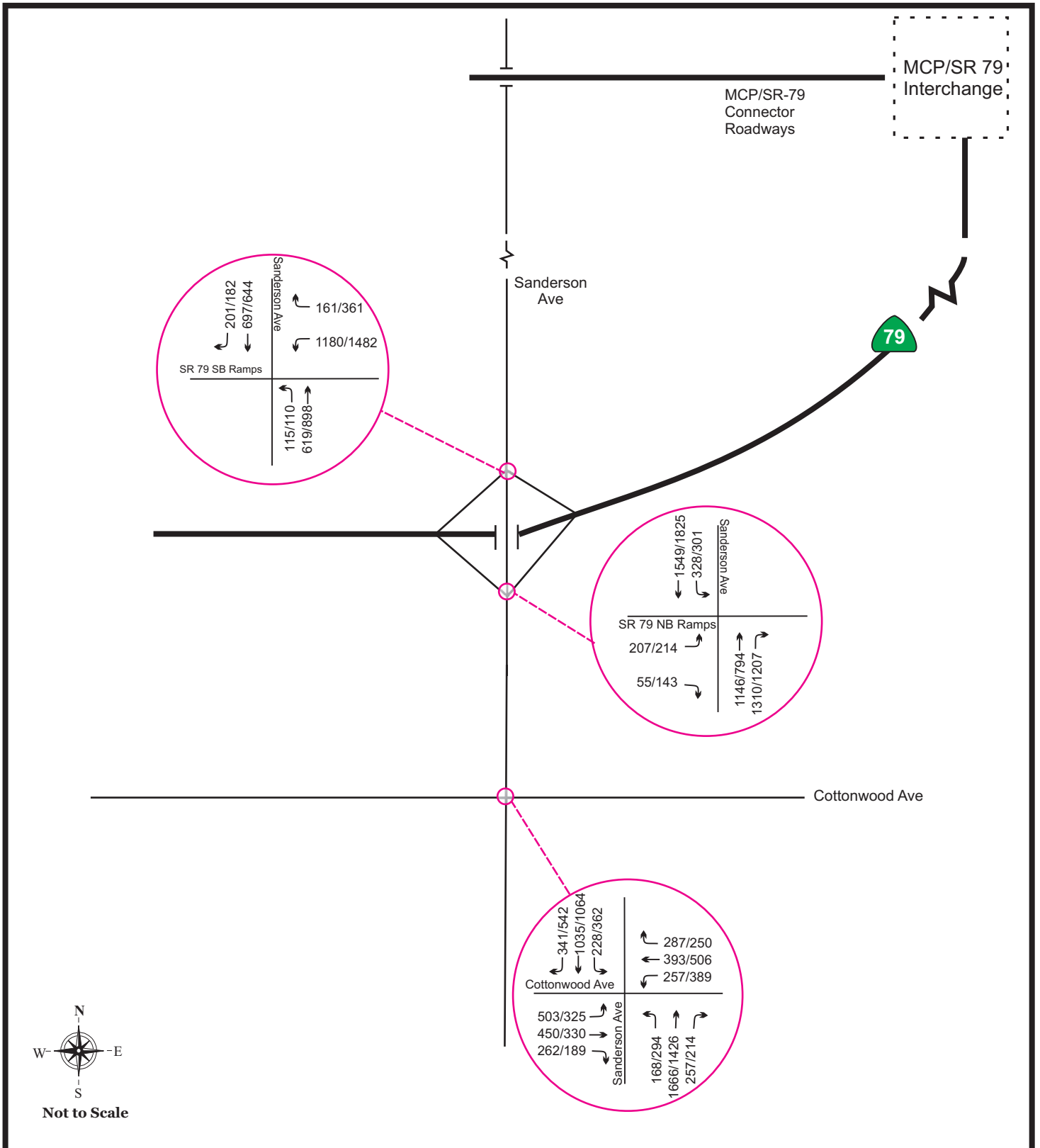

Horizon Year (2040) AM/PM Peak Hour Traffic Intersections - Alternative 9 Modified

Figure 7-51o

XXX/XXX AM/PM Peak Hour



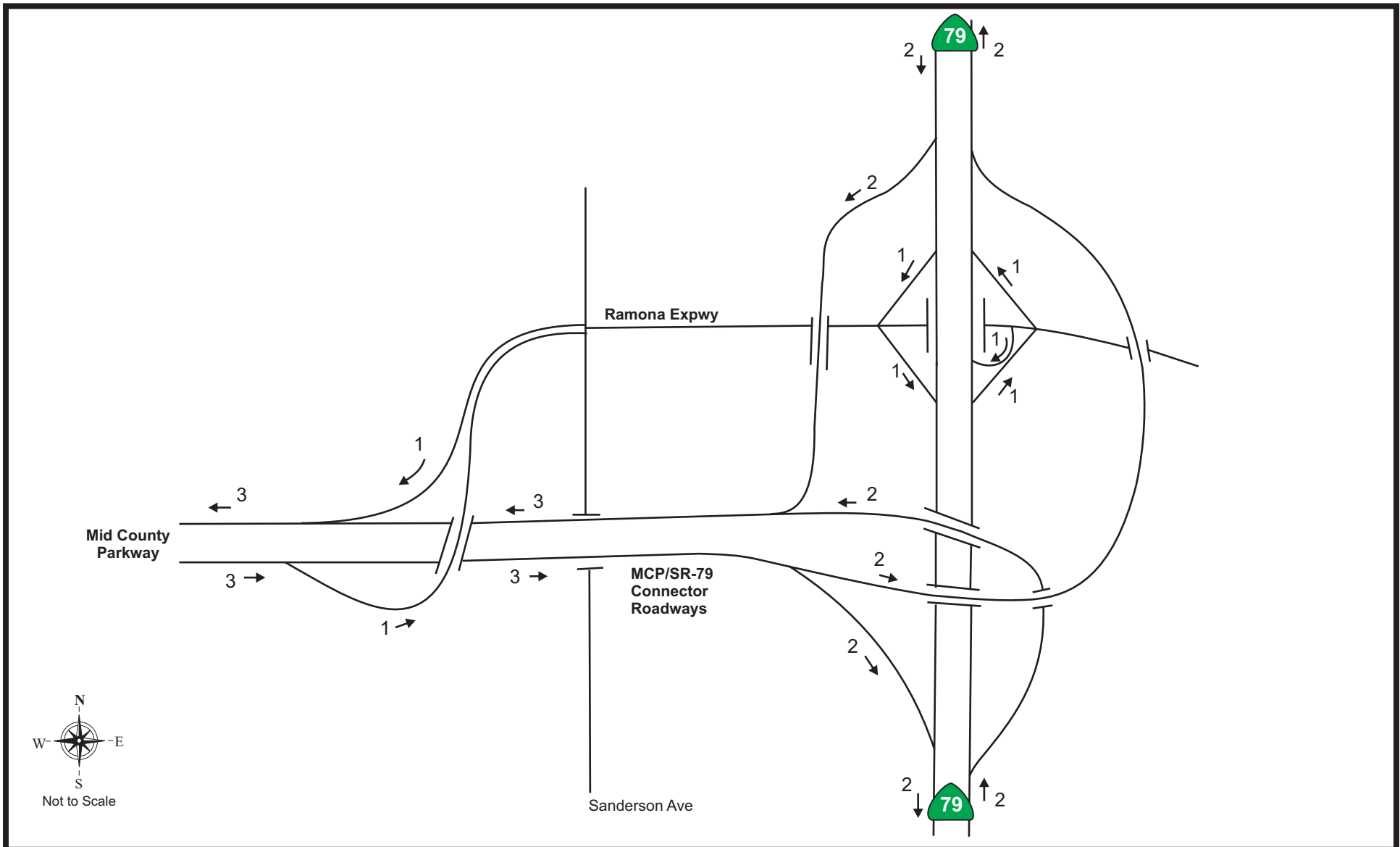

**Horizon Year (2040) MCP/SR-79 Interchange Area Lane Geometry
San Jacinto North Design Variation**

Figure 7-52

Legend

- xxxxx Average Daily Traffic
- xxxx AM Peak Hour
- xxxx PM Peak Hour



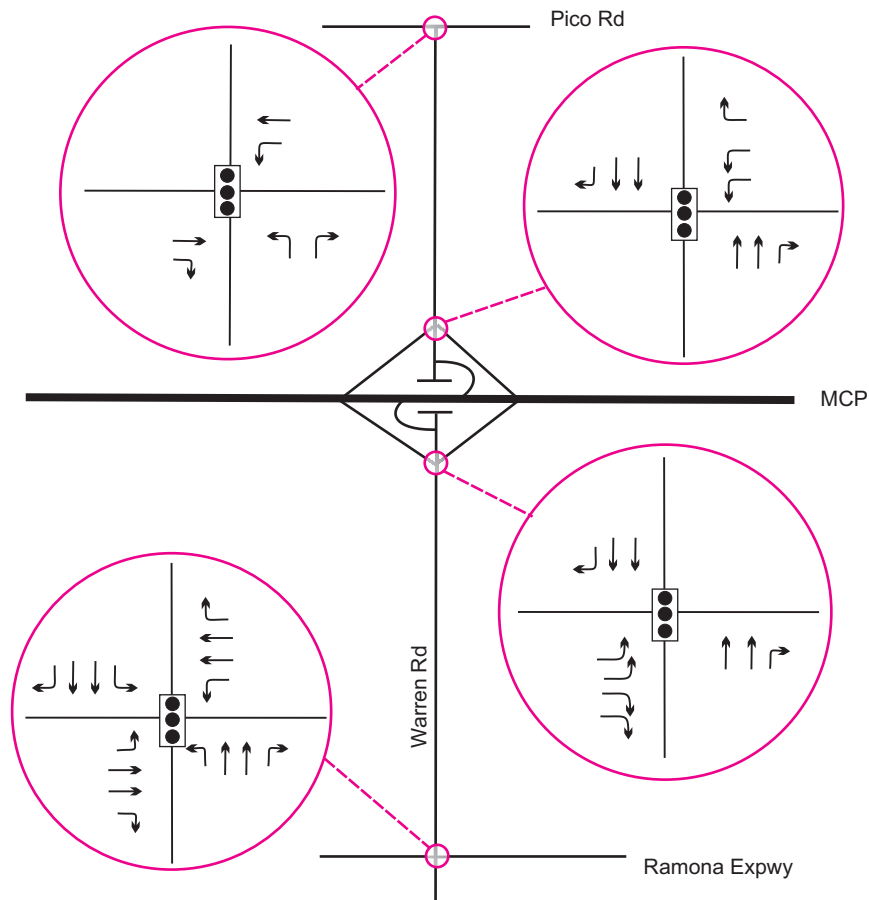

**Horizon Year (2040) Intersection Lane Geometry
San Jacinto North Design Variation**

Figure 7-53a



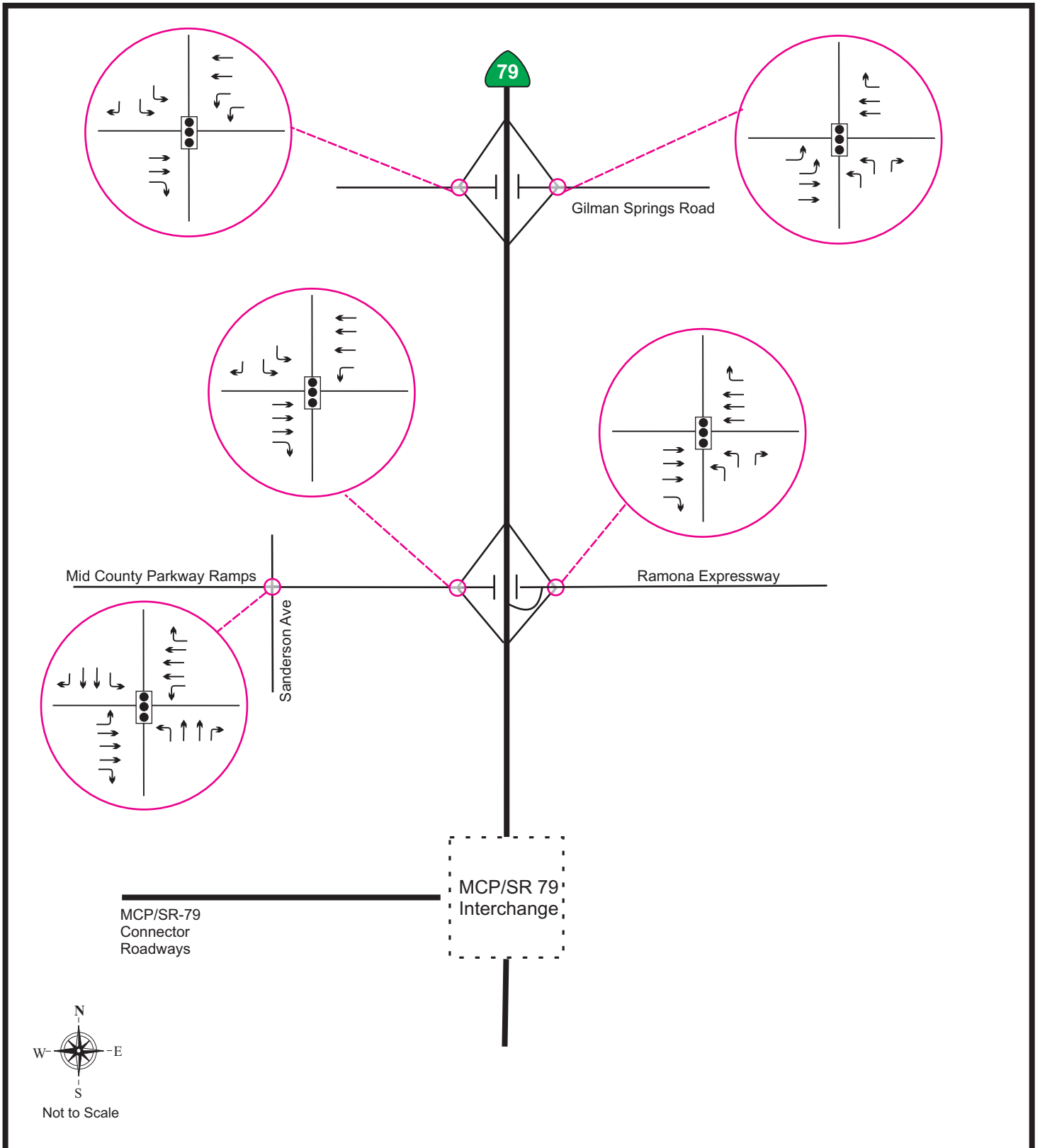

**Horizon Year (2040) Intersection Lane Geometry
San Jacinto North Design Variation**

Figure 7-53b

XXX/XXX AM/PM Peak Hour



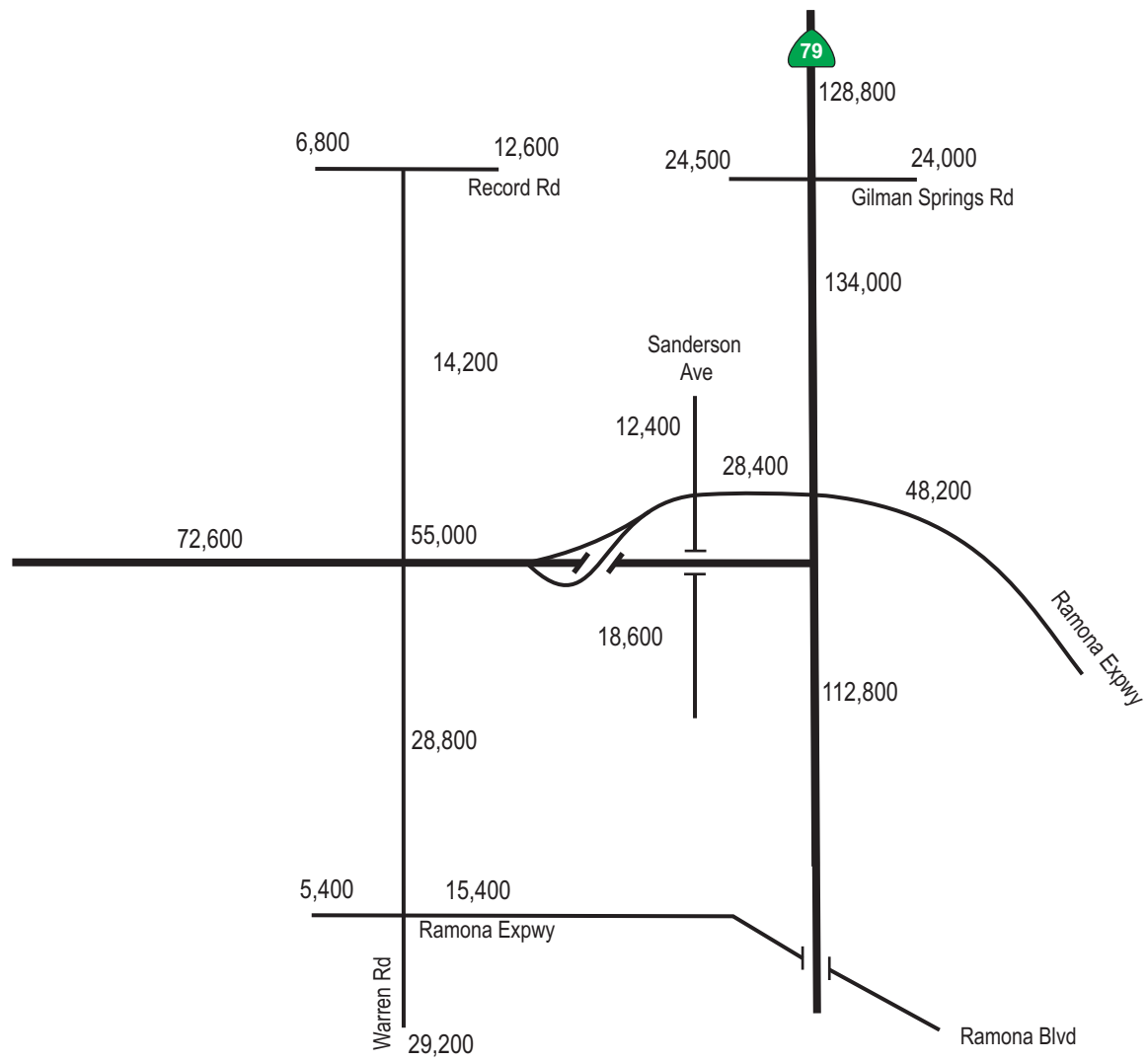

Horizon Year (2040) ADT - Freeway and Street Segments MCP Area - San Jacinto North Design Variation

Figure 7-54



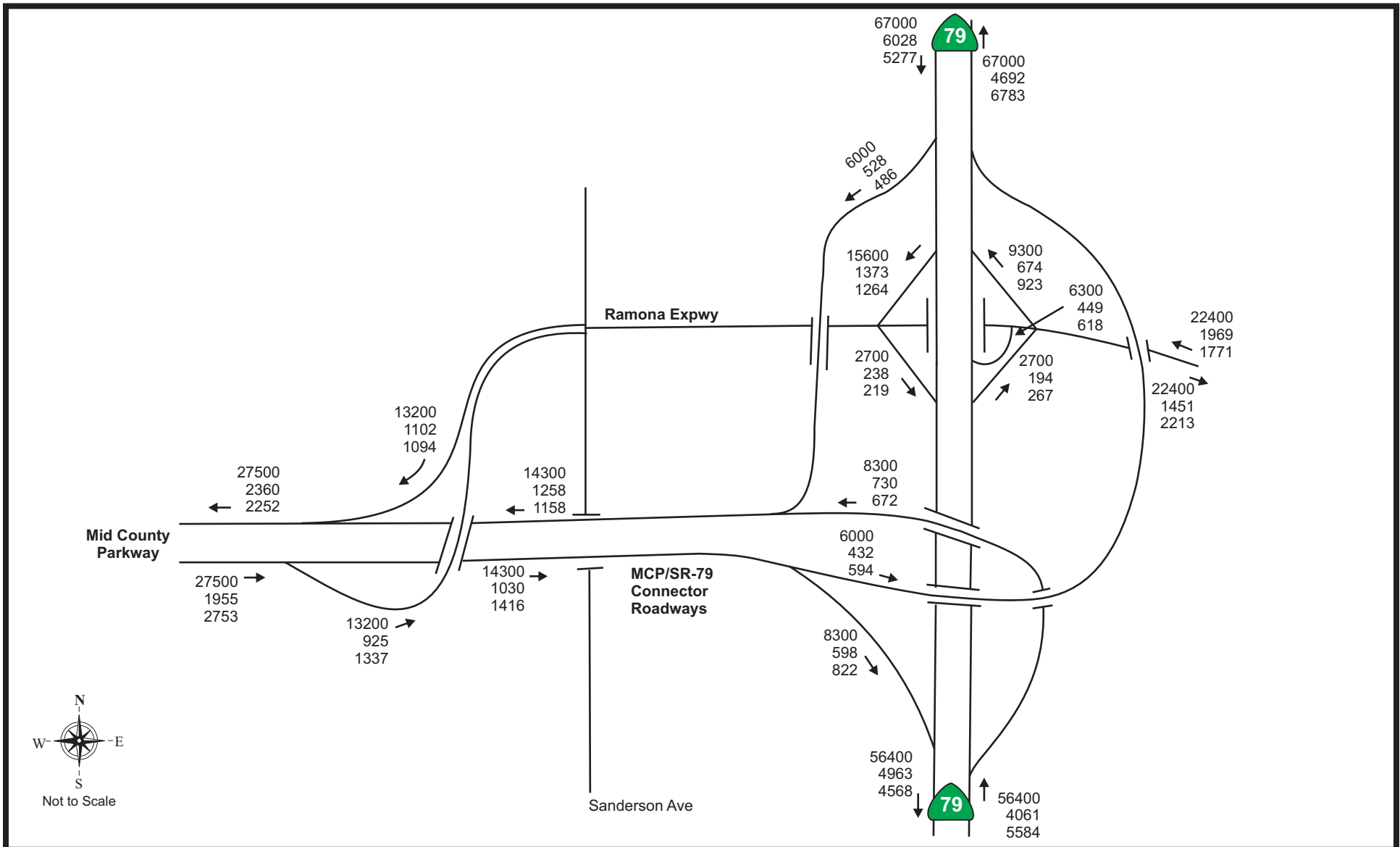

Horizon Year (2040) MCP/SR-79 Interchange Area Traffic - San Jacinto North Design Variation

Figure 7-55

Legend

- xx,xxx Average Daily Traffic
- x,xxx AM Peak Hour
- x,xxx PM Peak Hour



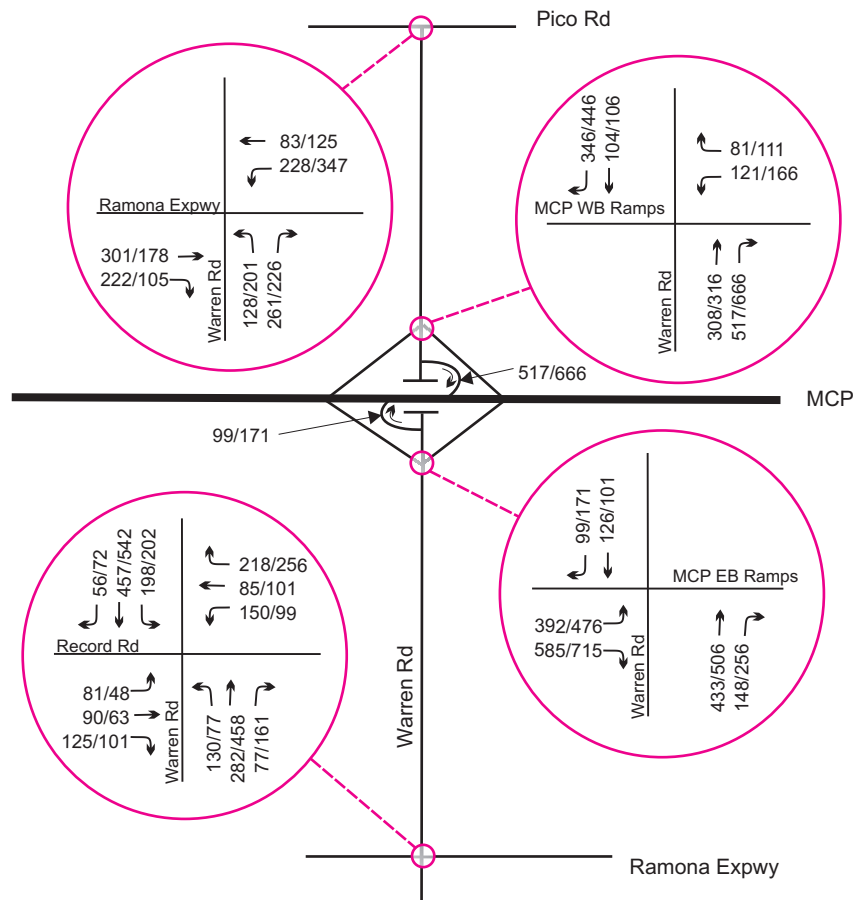

**Horizon Year (2040) AM/PM Peak Hour Traffic Intersections
San Jacinto North Design Variation**

Figure 7-56a

XXX/XXX AM/PM Peak Hour



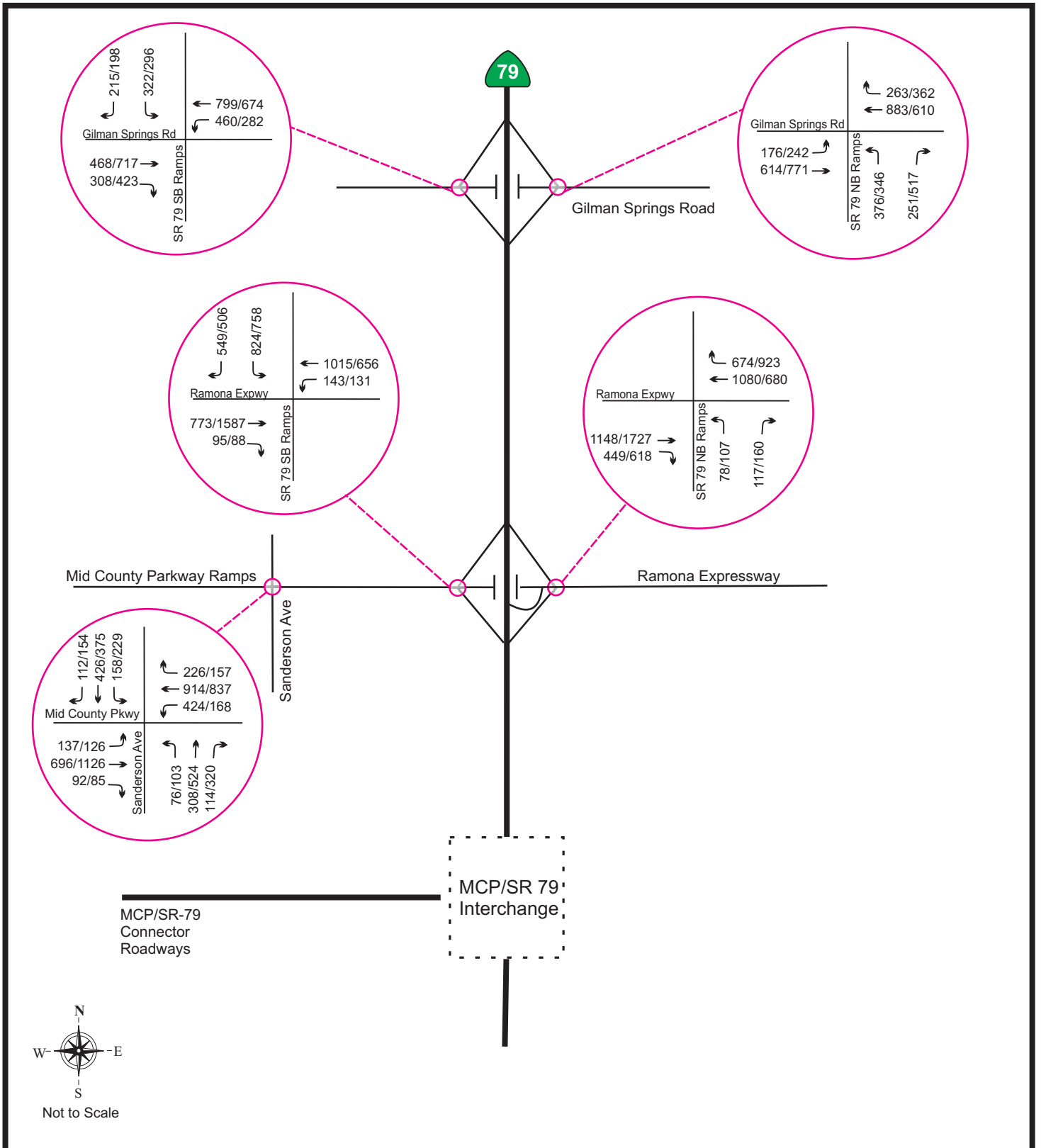

Horizon Year (2040) AM/PM Peak Hour Traffic Intersections - San Jacinto North Design Variation

Figure 7-56b

XXX/XXX AM/PM Peak Hour



Table 7-1
Horizon Year (2040)
Freeway and HOV Lane Capacity Analysis (1)
Interstate 15 - No Build

Northbound		Peak Hour Traffic (veh/hr)				Number of Lanes		Freeway Mainline and HOV Level of Service (2)				
		AM		PM				Freeway Capacity (3)	AM Peak Hour		PM Peak Hour	
Location	Facility	Freeway	HOV	Freeway	HOV	Freeway	HOV		LOS (4)	Density (5)	LOS (4)	Density (5)
I - 15 Mainline												
South of Temescal Canyon Rd	Freeway	7533		7617		4		8690	D	33.4	D	34.0
South of Temescal Canyon Rd	HOV		2904		2693		2		C	25.0	C	23.2
Temescal Canyon Rd On Ramp to Weirick Rd Off Ramp	Freeway	7912		7802		4		8690	E	36.4	E	35.5
Temescal Canyon Rd On Ramp to Weirick Rd Off Ramp	HOV		2904		2693		2		C	25.0	C	23.2
Weirick Rd On Ramp to Cajalco Rd Off Ramp	Freeway	8688		8369		4		8690	E	44.9	E	41.0
Weirick Rd On Ramp to Cajalco Rd Off Ramp	HOV		2904		2693		2		C	25.0	C	23.2
Cajalco Rd On Ramp to El Cerrito Rd Off Ramp	Freeway	9521		8763		4		8690	F	49.3	F	45.4
Cajalco Rd On Ramp to El Cerrito Rd Off Ramp	HOV		2904		2693		2		C	25.0	C	23.2
El Cerrito Rd On Ramp to Ontario Ave Off Ramp	Freeway	9143		7809		4		8690	F	47.3	E	35.5
El Cerrito Rd On Ramp to Ontario Ave Off Ramp	HOV		3600		3600		2		D	32.2	D	32.2
Ontario Ave On Ramp to Magnolia Ave Off Ramp	Freeway	9282		8011		4		8690	F	48.1	E	37.3
Ontario Ave On Ramp to Magnolia Ave Off Ramp	HOV		3600		3600		2		D	32.2	D	32.2
North of Magnolia Ave to SR-91	Freeway	9836		8416		4		8690	F	50.9	E	41.5
North of Magnolia Ave to SR-91	HOV		3600		3600		2		D	32.2	D	32.2

(1) Capacity Analysis shown for freeway mainline and HOV lanes. See separate page of Table 7-1 for ramps.

(2) One-lane HOV Lane density and level of service calculated using conditions for two freeway lanes and doubling the peak hour traffic.

(3) Freeway capacity is defined as the capacity at level of service E, expressed in vehicles per hour.

(4) LOS = Level of Service.

(5) Density is expressed in passenger cars/mile/lane. For facilities at level of service F, the density shown is the theoretical density that would occur if all demand could be accommodated.

Table 7-1
Horizon Year (2040)
Freeway and HOV Lane Capacity Analysis (1)
Interstate 15 - No Build

Northbound		Peak Hour Traffic (veh/hr)				Number of Lanes		Freeway Mainline and HOV Level of Service (2)				
		AM		PM				Freeway Capacity (3)	AM Peak Hour		PM Peak Hour	
Location	Facility	Freeway	HOV	Freeway	HOV	Freeway	HOV		LOS (4)	Density (5)	LOS (4)	Density (5)
I - 15 Mainline												
South of Temescal Canyon Rd	Freeway	7533		7617		4		8690	D	33.4	D	34.0
South of Temescal Canyon Rd	HOV		2904		2693		2		C	25.0	C	23.2
Temescal Canyon Rd On Ramp to Weirick Rd Off Ramp	Freeway	7912		7802		4		8690	E	36.4	E	35.5
Temescal Canyon Rd On Ramp to Weirick Rd Off Ramp	HOV		2904		2693		2		C	25.0	C	23.2
Weirick Rd On Ramp to Cajalco Rd Off Ramp	Freeway	8688		8369		4		8690	E	44.9	E	41.0
Weirick Rd On Ramp to Cajalco Rd Off Ramp	HOV		2904		2693		2		C	25.0	C	23.2
Cajalco Rd On Ramp to El Cerrito Rd Off Ramp	Freeway	9521		8763		4		8690	F	49.3	F	45.4
Cajalco Rd On Ramp to El Cerrito Rd Off Ramp	HOV		2904		2693		2		C	25.0	C	23.2
El Cerrito Rd On Ramp to Ontario Ave Off Ramp	Freeway	9143		7809		4		8690	F	47.3	E	35.5
El Cerrito Rd On Ramp to Ontario Ave Off Ramp	HOV		3600		3600		2		D	32.2	D	32.2
Ontario Ave On Ramp to Magnolia Ave Off Ramp	Freeway	9282		8011		4		8690	F	48.1	E	37.3
Ontario Ave On Ramp to Magnolia Ave Off Ramp	HOV		3600		3600		2		D	32.2	D	32.2
North of Magnolia Ave to SR-91	Freeway	9836		8416		4		8690	F	50.9	E	41.5
North of Magnolia Ave to SR-91	HOV		3600		3600		2		D	32.2	D	32.2

(1) Capacity Analysis shown for freeway mainline and HOV lanes. See separate page of Table 7-1 for ramps.

(2) One-lane HOV Lane density and level of service calculated using conditions for two freeway lanes and doubling the peak hour traffic.

(3) Freeway capacity is defined as the capacity at level of service E, expressed in vehicles per hour.

(4) LOS = Level of Service.

(5) Density is expressed in passenger cars/mile/lane. For facilities at level of service F, the density shown is the theoretical density that would occur if all demand could be accommodated.

Table 7-1 (cont.)
Horizon Year (2040)
Ramp Capacity Analysis (1)
Interstate 15 - No Build

Northbound		Peak Hour Traffic (veh/hr)				Number of Lanes		Ramp Level of Service			
		AM		PM				AM Peak Hour		PM Peak Hour	
Location	Facility	Freeway	Ramp	Freeway	Ramp	Freeway	Ramp	LOS (2)	Density (3)	LOS (2)	Density (3)
I - 15 Mainline											
Temescal Canyon Rd Off Ramp	Diverge	7533	360	7617	495	4	1	D	32.3	D	33.4
Temescal Canyon Rd On Ramp	Merge	7173	739	7122	680	4	2	C	25.1	C	24.9
Weirick Rd Off Ramp	Diverge	7912	324	7802	446	4	1	D	33.7	D	33.9
Weirick Rd On Ramp	Merge	7588	1108	7356	1013	4	2	C	25.8	C	25.4
Cajalco Rd Off Ramp	Diverge	8688	821	8369	1129	4	1	F	45.0	F	45.0
Cajalco Rd EB On Ramp	Merge	7867	616	7240	567	4	2	C	26.8	C	25.3
Cajalco Rd WB On Ramp	Merge	8483	1038	7807	956	4	1	F	49.3	C	26.3
El Cerrito Rd Off Ramp	Diverge	9521	497	8763	683	4	2	F	49.3	F	45.4
El Cerrito Rd On Ramp	Merge	9024	815	8080	656	4	1	F	47.3	C	27.3
Ontario Ave Off Ramp	Diverge	9143	986	7809	907	4	2	F	47.3	E	36.3
Ontario Ave On Ramp	Merge	8157	1125	6902	1109	4	1	F	48.1	C	24.4
Magnolia Ave Off Ramp	Diverge	9282	1250	8011	1021	4	2	F	48.1	F	45.0
Magnolia Ave EB On Ramp	Merge	8032	1203	6990	951	4	1	F	50.9	C	24.6
Magnolia Ave WB On Ramp	Merge	9235	601	7941	475	4	2	F	50.9	C	27.2

(1) Capacity analysis shown for ramps only. See separate page of Table 7-1 for freeway mainline and HOV lanes.

(2) LOS = Level of Service

(3) Density is expressed in passenger cars/mile per lane. For facilities at level of service F, the density shown is the theoretical density that would occur if all demand could be accommodated.

Table 7-1 (cont.)
Horizon Year (2040)
Freeway and HOV Lane Capacity Analysis (1)
Interstate 15 - No Build

Southbound		Peak Hour Traffic (veh/hr)				Number of Lanes		Freeway Mainline and HOV Level of Service (2)				
		AM		PM				Freeway Capacity (3)	AM Peak Hour		PM Peak Hour	
Location	Facility	Freeway	HOV	Freeway	HOV	Freeway	HOV		LOS (4)	Density (5)	LOS (4)	Density (5)
I - 15 Mainline												
SR-91 to Magnolia Ave	Freeway	9001		10833		4		8690	F	46.6	F	56.1
SR-91 to Magnolia Ave	HOV		2918		3600		2		C	25.2	D	32.2
Magnolia Ave On Ramp to Ontario Ave Off Ramp	Freeway	7718		10455		4		8690	D	34.8	F	54.1
Magnolia Ave On Ramp to Ontario Ave Off Ramp	HOV		2918		3600		2		C	25.2	D	32.2
Ontario Ave On Ramp to El Cerrito Rd Off Ramp	Freeway	7765		10955		4		8690	E	35.2	F	56.7
Ontario Ave On Ramp to El Cerrito Rd Off Ramp	HOV		2918		3600		2		C	25.2	D	32.2
El Cerrito Rd On Ramp to Cajalco Rd Off Ramp	Freeway	7789		10712		4		8690	E	35.4	F	55.5
El Cerrito Rd On Ramp to Cajalco Rd Off Ramp	HOV		2376		3267		2		C	20.5	D	28.4
Cajalco Rd On Ramp to Weirick Rd Off Ramp	Freeway	7438		9774		4		8690	D	32.7	F	50.6
Cajalco Rd On Ramp to Weirick Rd Off Ramp	HOV		2376		3267		2		C	20.5	D	28.4
Weirick Rd On Ramp to Temescal Canyon Rd Off Ramp	Freeway	6934		8901		4		8690	D	29.5	F	46.1
Weirick Rd On Ramp to Temescal Canyon Rd Off Ramp	HOV		2376		3267		2		C	20.5	D	28.4
South of Temescal Canyon Rd	Freeway	6769		8474		4		8690	D	28.6	E	42.2
South of Temescal Canyon Rd	HOV		2376		3267		2		C	20.5	D	28.4

(1) Capacity Analysis shown for freeway mainline and HOV lanes. See separate page of Table 7-1 for ramps.

(2) One-lane HOV Lane density and level of service calculated using conditions for two freeway lanes and doubling the peak hour traffic.

(3) Freeway capacity is defined as the capacity at level of service E, expressed in vehicles per hour.

(4) LOS = Level of Service.

(5) Density is expressed in passenger cars/mile/lane. For facilities at level of service F, the density shown is the theoretical density that would occur if all demand could be accommodated.

Table 7-1 (cont.)
Horizon Year (2040)
Ramp Capacity Analysis (1)
Interstate 15 - No Build

Southbound		Peak Hour Traffic (veh/hr)				Number of Lanes		Ramp Level of Service			
		AM		PM				AM Peak Hour		PM Peak Hour	
Location	Facility	Freeway	Ramp	Freeway	Ramp	Freeway	Ramp	LOS (2)	Density (3)	LOS (2)	Density (3)
I - 15 Mainline											
Magnolia Ave Off Ramp	Diverge	9001	2190	10833	1625	4	1	F	46.6	F	56.1
Magnolia Ave On Ramp	Merge	6811	907	9208	1427	4	2	C	24.2	F	45.0
Ontario Ave Off Ramp	Diverge	7718	1289	10455	942	4	1	F	45.0	F	54.1
Ontario Ave On Ramp	Merge	6429	806	9513	1109	4	2	C	23.3	F	56.7
El Cerrito Rd Off Ramp	Diverge	7765	583	10955	802	4	1	D	34.5	F	56.7
El Cerrito Rd On Ramp	Merge	7182	607	10153	559	4	2	C	25.1	F	55.5
Cajalco Rd Off Ramp	Diverge	7789	1354	10712	1861	4	1	F	45.0	F	55.5
Cajalco Rd On Ramp	Merge	6435	1003	8851	923	4	2	C	23.5	F	45.0
Weirick Rd Off Ramp	Diverge	7438	900	9774	1238	4	1	D	34.8	F	45.0
Weirick Rd On Ramp	Merge	6538	396	8536	365	4	2	C	23.4	F	45.0
Temescal Canyon Rd Off Ramp	Diverge	6934	605	8901	832	4	1	D	31.2	F	45.0
Temescal Canyon Rd On Ramp	Merge	6329	440	8069	405	4	2	C	22.9	C	27.6

(1) Capacity analysis shown for ramps only. See separate page of Table 7-1 for freeway mainline and HOV lanes.

(2) LOS = Level of Service

(3) Density is expressed in passenger cars/mile per lane. For facilities at level of service F, the density shown is the theoretical density that would occur if all demand could be accommodated.

Table 7-2 (cont.)
Horizon Year (2040)
Ramp Capacity Analysis (1)
Interstate 215 - No Build

Northbound		Peak Hour Traffic (veh/hr)				Number of Lanes		Ramp Level of Service			
		AM		PM				AM Peak Hour		PM Peak Hour	
Location	Facility	Freeway	Ramp	Freeway	Ramp	Freeway	Ramp	LOS (2)	Density (3)	LOS (2)	Density (3)
I - 215 Mainline											
D Street On Ramp to Nuevo Rd Off Ramp	Weave (4)	7834		7459		4		E	36.1	D	34.9
Nuevo Rd Off Ramp	Diverge (5)	7834	547	7459	752	4	2	B	13.6	B	14.1
Nuevo Rd On Ramp	Merge	7287	774	6707	713	3	1	F	56.1	F	51.6
Cajalco/Ramona Expwy Off Ramp	Diverge	6261	576	5620	792	3	1	D	34.9	D	32.8
Cajalco/Ramona Expwy On Ramp	Merge	5685	1416	4828	1301	3	1	F	49.4	E	36.9
Harley Knox Blvd Off Ramp	Diverge	7101	519	6129	478	3	1	F	49.4	D	34.3
Harley Knox Blvd On Ramp	Merge	6582	972	5651	1159	3	1	F	52.5	F	47.4
Van Buren Blvd Off Ramp	Diverge	7554	958	6810	883	3	2	F	52.5	F	47.4
Van Buren Blvd EB On Ramp	Merge	6596	616	5927	567	3	1	F	50.2	E	36.6
Van Buren Blvd WB On Ramp	Merge	7212	246	6494	227	3	1	F	51.9	F	46.7
Cactus Ave Off Ramp	Diverge	7458	910	6721	769	3	1	F	51.9	F	46.7
Cactus Ave EB On Ramp	Merge	6548	316	5952	226	3	1	F	47.7	D	34.0
Cactus Ave WB On Ramp	Merge	6864	453	6178	414	3	1	F	50.9	E	36.6
Alessandro Blvd Off Ramp	Diverge	7317	824	6592	1001	3	1	F	50.9	E	36.8
Alessandro Blvd On Ramp	Merge	6493	533	5591	733	3	1	F	48.9	E	36.2

(1) Capacity analysis shown for ramps only. See separate page of Table 7-2 for freeway mainline and HOV lanes.

(2) LOS = Level of Service.

(3) Density is expressed in passenger cars/mile/lane. For facilities at level of service F, the density shown is the theoretical density that would occur if all demand could be accommodated based on capacity of the adjacent freeway segment.

(4) For weaving volumes, see Figure 7-4c. The ramp to ramp movement was assumed to be zero. Weaving length is 2,000 feet per the I-215 widening project.

(5) Ramp capacity analysis shown for information only, since this is technically part of a weaving section.

Table 7-2 (cont.)
 Horizon Year (2040)
 Freeway and HOV Lane Capacity Analysis (1)
 Interstate 215 - No Build

Southbound		Peak Hour Traffic (veh/hr)				Number of Lanes		Freeway Mainline and HOV Level of Service (2)					
		AM		PM				Freeway Capacity (3)	AM Peak Hour		PM Peak Hour		
		Freeway	HOV	Freeway	HOV				LOS (4)	Density (5)	LOS (4)	Density (5)	
Location	Facility												
I - 215 Mainline													
North of Alessandro Blvd	Freeway	5422		8130		3		6470	D	31.8	F	56.5	
North of Alessandro Blvd	HOV		1800		1800		1	6470	D	32.2	D	32.2	
Alessandro Blvd On Ramp to Cactus Ave Off Ramp	Freeway	5659		8456		3		6470	D	34.0	F	58.8	
Alessandro Blvd On Ramp to Cactus Ave Off Ramp	HOV		1800		1800		1	6470	D	32.2	D	32.2	
Cactus Ave On Ramp to Van Buren Blvd Off Ramp	Freeway	5774		8615		3		6470	E	35.2	F	59.9	
Cactus Ave On Ramp to Van Buren Blvd Off Ramp	HOV		1800		1800		1	6470	D	32.2	D	32.2	
Van Buren Blvd On Ramp to Harley Knox Blvd Off Ramp	Freeway	5854		8724		3		6470	E	36.1	F	60.7	
Van Buren Blvd On Ramp to Harley Knox Blvd Off Ramp	HOV		1800		1800		1	6470	D	32.2	D	32.2	
Harley Knox Blvd On Ramp to Cajalco/Ramona Expwy Off Ramp	Freeway	5382		8204		3		6470	D	31.5	F	57.1	
Harley Knox Blvd On Ramp to Cajalco/Ramona Expwy Off Ramp	HOV		1800		1800		1	6470	D	32.2	D	32.2	
Cajalco/Ramona Expwy On Ramp to Nuevo Rd Off Ramp	Freeway	4795		7268		3		6470	D	27.2	F	50.6	
Cajalco/Ramona Expwy On Ramp to Nuevo Rd Off Ramp	HOV		1800		1800		1	6470	D	32.2	D	32.2	

(1) Capacity Analysis shown for freeway mainline and HOV lanes. See separate page of Table 7-2 for ramps.

(2) One-lane HOV Lane density and level of service calculated using conditions for two freeway lanes and doubling the peak hour traffic.

(3) Freeway capacity is defined as the capacity at level of service E, expressed in vehicles per hour.

(4) LOS = Level of Service.

(5) Density is expressed in passenger cars/mile/lane. For facilities at level of service F, the density shown is the theoretical density that would occur if all demand could be accommodated.

Table 7-2 (cont.)
Horizon Year (2040)
Ramp Capacity Analysis (1)
Interstate 215 - No Build

Southbound		Peak Hour Traffic (veh/hr)				Number of Lanes		Ramp Level of Service			
		AM		PM				AM Peak Hour		PM Peak Hour	
Location	Facility	Freeway	Ramp	Freeway	Ramp	Freeway	Ramp	LOS (2)	Density (3)	LOS (2)	Density (3)
I - 215 Mainline											
Alessandro Blvd Off Ramp	Diverge	5422	652	8130	599	3	1	D	31.7	F	56.5
Alessandro Blvd WB On Ramp	Merge	4770	241	7531	251	3	1	D	28.2	F	54.1
Alessandro Blvd EB On Ramp	Merge	5011	648	7782	674	3	1	D	32.6	F	58.8
Cactus Ave WB Off Ramp	Diverge	5659	431	8456	485	3	1	D	32.3	F	58.8
Cactus Ave EB Off Ramp	Diverge	5228	264	7971	297	3	1	D	30.3	F	55.4
Cactus Ave On Ramp	Merge	4964	810	7674	941	3	1	D	33.7	F	59.9
Van Buren Blvd Off Ramp	Diverge	5774	706	8615	970	3	1	D	33.2	F	59.9
Van Buren Blvd On Ramp	Merge	5068	786	7645	1079	3	1	D	34.0	F	60.7
Harley Knox Blvd Off Ramp	Diverge	5854	897	8724	1104	3	1	D	33.9	F	60.7
Harley Knox Blvd On Ramp	Merge	4957	425	7620	584	3	1	D	30.6	F	57.1
Cajalco/Ramona Expwy Off Ramp	Diverge	5382	1291	8204	1584	3	1	D	32.8	F	57.1
Cajalco/Ramona Expwy On Ramp	Merge	4091	704	6620	648	3	1	D	28.5	F	50.6
Nuevo Rd Off Ramp	Diverge	6595	634	9068	871	3	1	E	36.3	F	63.1
Nuevo Rd On Ramp	Merge (4)	5961	669	8197	616	3	1	F	46.1	F	61.3
Nuevo Rd On Ramp to D Street Off Ramp	Weave (5)	6303		8009		4		D	34.0	E	47.7

(1) Capacity analysis shown for ramps only. See separate page of Table 7-2 for freeway mainline and HOV lanes.

(2) LOS = Level of Service.

(3) Density is expressed in passenger cars/mile/lane.

(4) Ramp capacity analysis shown for information only, since this is technically part of a weaving section.

(5) For weaving volumes, see Figure 7-4c. The ramp to ramp movement was assumed to be zero. Weaving length is 2,000 feet per the I-215 widening project.

Table 7-3
Horizon Year (2040)
No Build / Existing Conditions
Intersection Capacity Analysis
I-15 Area

Intersection	AM Peak Hour		PM Peak Hour	
	LOS	Average Delay (sec)	LOS	Average Delay (sec)
Magnolia Avenue and El Sobrante Road	F	>80.0	F	>80.0
Magnolia Avenue and I-15 Southbound Ramps	F	>80.0	F	>80.0
Magnolia Avenue and I-15 Northbound Ramps	B	18.0	C	23.9
Magnolia Avenue and El Camino Ave	C	20.1	E	70.6
Ontario Avenue and California Avenue	D	51.0	F	>80.0
Ontario Avenue and I-15 Southbound Ramps	C	23.4	B	15.2
Ontario Avenue and I-15 Northbound Ramps	C	29.3	C	33.3
Ontario Avenue and State Street	B	13.0	B	13.2
El Cerrito Road and Bedford Canyon Road	C	26.7	C	28.0
El Cerrito Road and I-15 Southbound Ramps	B	17.5	C	22.7
El Cerrito Road and I-15 Northbound Ramps	D	35.6	C	20.8
El Cerrito Road and Temescal Canyon Road	C	31.4	C	30.7
Cajalco Road and Bedford Canyon Road	C	20.1	C	31.1
Cajalco Road and I-15 Southbound Ramps	C	23.9	C	23.8
Cajalco Road and I-15 Northbound Ramps	B	10.5	B	14.8
Cajalco Road and Temescal Canyon Road	E	61.4	F	>80.0
Weirick Road and Knabe Road	D	39.5	C	31.1
Weirick Road and I-15 Southbound Ramps	C	22.6	B	16.2
Weirick Road and I-15 Northbound Ramps	A	9.4	B	11.0
Weirick Road and Temescal Canyon Road	C	22.2	C	29.3
Temescal Canyon Road and Lawson Drive	C	20.4	B	18.8
Temescal Canyon Road and I-15 Southbound Ramps	B	15.5	D	38.4
Temescal Canyon Road and I-15 Northbound Ramps	C	22.5	C	24.9

Notes:

">80" – Exceeds 80 seconds

Table 7-3 (cont.)
Horizon Year (2040)
No Build / Existing Conditions
Intersection Capacity Analysis
Cajalco Road, I-15 to I-215

Intersection	AM Peak Hour		PM Peak Hour	
	LOS	Average Delay (sec)	LOS	Average Delay (sec)
Eagle Valley Road and Cajalco Road	C	20.2	B	19.5
Lake Matthews Road and Cajalco Road	B	11.4	B	18.0
El Sobrante Road and Calalco Road	B	18.7	B	15.6
Wood Road and Cajalco Road	C	22.7	C	31.2
Alexander Street and Cajalco Road	B	18.5	B	17.7
Clark Street and Cajalco Road	C	30.7	D	38.5

Notes:

">80" – Exceeds 80 seconds

Table 7-3 (cont.)
Horizon Year (2040)
No Build / Existing Conditions
Intersection Capacity Analysis
I-215 Area

Intersection	AM Peak Hour		PM Peak Hour	
	LOS	Average Delay (sec)	LOS	Average Delay (sec)
Alessandro Blvd and Meridian Parkway	F	>80.0	F	>80.0
Alessandro Blvd and I-215 Southbound Ramps	E	61.4	F	>80.0
Alessandro Blvd and I-215 Northbound Ramps	D	53.5	F	>80.0
Alessandro Blvd and Valley Springs Parkway	E	74.8	F	>80.0
Cactus Avenue and Innovation Drive	C	29.9	F	>80.0
Cactus Avenue and I-215 Southbound Ramps	B	17.4	C	22.4
Cactus Avenue and I-215 Northbound Ramps	C	26.6	C	33.7
Cactus Avenue and Ellsworth Street	D	43.5	D	38.7
Van Buren Boulevard and Meridian Parkway	C	27.2	E	63.8
Van Buren Boulevard and I-215 Southbound Ramps	B	12.6	B	14.6
Van Buren Boulevard and I-215 Northbound Ramps	C	21.5	B	15.0
Harley Knox Blvd and Harvill Avenue	C	20.8	C	21.8
Harley Knox Blvd and I-215 Southbound Ramps	F	>80.0	F	>80.0
Harley Knox Blvd and I-215 Northbound Ramps	F	>80.0	F	>80.0
Harley Knox Blvd and Western Way	B	18.7	B	12.2
Cajalco Road and Harvill Avenue	D	37.5	D	37.7
Cajalco Road and I-215 Southbound Ramps	C	21.3	C	24.8
Cajalco Road and I-215 Northbound Ramps	B	19.6	C	24.5
Cajalco Road and Webster Avenue	C	31.1	D	46.5
Placentia Avenue and Harvill Avenue	D	36.6	D	38.7
Placentia Avenue and East Frontage Road	B	18.5	B	18.3
Nuevo Road and A Street	B	17.4	C	23.1
Nuevo Road and I-215 Southbound Ramps	C	24.5	C	24.0
Nuevo Road and I-215 Northbound Ramps	A	8.3	B	15.1
Nuevo Road and Old Nuevo Road	D	42.8	D	38.4

Notes:

">80" – Exceeds 80 seconds

Table 7-3 (cont.)
Horizon Year (2040)
No Build / Existing Conditions
Intersection Capacity Analysis
Ramona Expressway, I-215 to SR 79

Intersection	AM Peak Hour		PM Peak Hour	
	LOS	Average Delay (sec)	LOS	Average Delay (sec)
Perris Boulevard and Markham Street	B	19.9	C	20.7
Perris Boulevard and Ramona Expressway	E	60.3	E	58.5
Perris Boulevard and Morgan Street	C	27.9	C	29.6
Redlands Avenue and Ramona Expressway	D	50.0	E	71.8
Evans Road and Marbella Gate	A	2.7	A	2.1
Evans Road and Ramona Expressway	F	>80.0	F	>80.0
Evans Road and Morgan Street	A	8.5	A	7.5
Bernasconi Road and New Street	B	14.1	B	14.0
Bernasconi Road and Ramona Expressway	F	>80.0	F	>80.0
Bernasconi Road and Orange Avenue	C	28.0	C	33.8
Reservoir Avenue and Martin St	B	17.5	B	17.3
Reservoir Avenue and Ramona Expressway	F	>80.0	F	>80.0
Reservoir Avenue and 9th Street	B	14.4	B	14.0
Town Center Boulevard and Frontage Rd	B	11.1	B	10.3
Town Center Boulevard and Ramona Expressway	F	>80.0	F	>80.0
Town Center Boulevard and 5th Street	C	29.5	C	31.5
Park Center Boulevard and Marvin Road	C	32.5	C	29.6
Park Center Boulevard and Ramona Expressway	F	>80.0	F	>80.0
Park Center Boulevard and New Street	A	7.0	A	7.1
Warren Road and Ramona Expressway	E	69.3	D	38.4
Warren Road and Record Road	B	11.7	B	12.2
Gilman Springs Road and SR 79 Southbound Ramps	B	17.7	C	22.1
Gilman Springs Road and SR 79 Northbound Ramps	C	28.6	C	27.0
Ramona Expressway and SR 79 Southbound Ramps	D	35.4	D	38.8
Ramona Expressway and SR 79 Northbound Ramps	A	7.8	B	15.7
Sanderson Avenue and SR 79 WB Ramps	C	20.1	C	24.8
Sanderson Avenue and SR 79 EB Ramps	A	8.7	A	9.8
Sanderson Avenue and Cottonwood Avenue	D	38.0	D	37.7

Notes:

">80" – Exceeds 80 seconds

Table 7-4
Horizon Year (2040)
No Build / County General Plan
Intersection Capacity Analysis
I-15 Area

Intersection	AM Peak Hour		PM Peak Hour	
	LOS	Average Delay (sec)	LOS	Average Delay (sec)
Magnolia Avenue and El Sobrante Road	F	>80.0	F	>80.0
Magnolia Avenue and I-15 Southbound Ramps	F	>80.0	F	>80.0
Magnolia Avenue and I-15 Northbound Ramps	B	18.0	C	23.9
Magnolia Avenue and El Camino Ave	C	20.1	E	70.6
Ontario Avenue and California Avenue	D	51.0	F	>80.0
Ontario Avenue and I-15 Southbound Ramps	C	23.4	B	15.2
Ontario Avenue and I-15 Northbound Ramps	C	29.3	C	33.3
Ontario Avenue and State Street	B	13.0	B	13.2
El Cerrito Road and Bedford Canyon Road	C	26.7	C	28.0
El Cerrito Road and I-15 Southbound Ramps	B	17.5	C	22.7
El Cerrito Road and I-15 Northbound Ramps	D	35.6	C	20.8
El Cerrito Road and Temescal Canyon Road	C	31.4	C	30.7
Cajalco Road and Bedford Canyon Road	C	20.1	C	31.1
Cajalco Road and I-15 Southbound Ramps	C	23.9	C	23.8
Cajalco Road and I-15 Northbound Ramps	B	10.5	B	14.8
Cajalco Road and Temescal Canyon Road	E	61.4	F	>80.0
Weirick Road and Knabe Road	D	39.5	C	31.1
Weirick Road and I-15 Southbound Ramps	C	22.6	B	16.2
Weirick Road and I-15 Northbound Ramps	A	9.4	B	11.0
Weirick Road and Temescal Canyon Road	C	22.2	C	29.3
Temescal Canyon Road and Lawson Drive	C	20.4	B	18.8
Temescal Canyon Road and I-15 Southbound Ramps	B	15.5	D	38.4
Temescal Canyon Road and I-15 Northbound Ramps	C	22.5	C	24.9

Notes:

">80" – Exceeds 80 seconds

Table 7-4 (cont.)
Horizon Year (2040)
No Build / County General Plan
Intersection Capacity Analysis
Cajalco Road, I-15 to I-215

Intersection	AM Peak Hour		PM Peak Hour	
	LOS	Average Delay (sec)	LOS	Average Delay (sec)
Eagle Valley Road and Cajalco Road	C	20.2	B	19.5
Lake Matthews Road and Cajalco Road	B	11.4	B	18.0
El Sobrante Road and Calalco Road	B	18.7	B	15.6
Wood Road and Cajalco Road	C	22.7	C	31.2
Alexander Street and Cajalco Road	B	18.5	B	17.7
Clark Street and Cajalco Road	C	30.7	D	38.5

Notes:

">80" – Exceeds 80 seconds

Table 7-4 (cont.)
Horizon Year (2040)
No Build / County General Plan
Intersection Capacity Analysis
I-215 Area

Intersection	AM Peak Hour		PM Peak Hour	
	LOS	Average Delay (sec)	LOS	Average Delay (sec)
Alessandro Blvd and Meridian Parkway	F	>80.0	F	>80.0
Alessandro Blvd and I-215 Southbound Ramps	E	61.4	F	>80.0
Alessandro Blvd and I-215 Northbound Ramps	D	53.5	F	>80.0
Alessandro Blvd and Valley Springs Pkwy	E	74.8	F	>80.0
Cactus Avenue and Innovation Drive	C	29.9	F	>80.0
Cactus Avenue and I-215 Southbound Ramps	B	17.4	C	22.4
Cactus Avenue and I-215 Northbound Ramps	C	26.6	C	33.7
Cactus Avenue and Ellsworth Street	D	43.5	D	38.7
Van Buren Boulevard and Meridian Parkway	C	27.2	E	63.8
Van Buren Boulevard and I-215 Southbound Ramps	B	12.6	B	14.6
Van Buren Boulevard and I-215 Northbound Ramps	C	21.5	B	15.0
Harley Knox Blvd and Harvill Avenue	C	20.8	C	21.8
Harley Knox Blvd and I-215 Southbound Ramps	B	19.6	D	48.8
Harley Knox Blvd and I-215 Northbound Ramps	B	18.5	B	14.9
Harley Knox Blvd and Western Way	B	18.7	B	12.2
Cajalco Road and Harvill Avenue	D	37.4	D	38.3
Cajalco Road and I-215 Southbound Ramps	C	21.3	C	24.8
Cajalco Road and I-215 Northbound Ramps	B	19.6	C	24.5
Cajalco Road and Webster Avenue	C	31.5	D	42.4
Placentia Avenue and Harvill Avenue	D	36.6	D	38.7
Placentia Avenue and East Frontage Road	B	18.5	B	18.3
Nuevo Road and A Street	B	17.4	C	23.1
Nuevo Road and I-215 Southbound Ramps	C	24.5	C	24.0
Nuevo Road and I-215 Northbound Ramps	A	8.3	B	15.1
Nuevo Road and Old Nuevo Road	D	42.8	D	38.4

Notes:

">80" – Exceeds 80 seconds

Table 7-4 (cont.)
Horizon Year (2040)
No Build / County General Plan
Intersection Capacity Analysis
Ramona Expressway, I-215 to SR 79

Intersection	AM Peak Hour		PM Peak Hour	
	LOS	Average Delay (sec)	LOS	Average Delay (sec)
Perris Boulevard and Markham Street	B	20.0	C	20.9
Perris Boulevard and Ramona Expressway	D	41.5	D	42.2
Perris Boulevard and Morgan Street	C	28.0	C	29.8
Redlands Avenue and Ramona Expressway	D	50.0	E	71.8
Evans Road and Marbella Gate	A	2.9	A	2.0
Evans Road and Ramona Expressway	E	62.5	E	58.3
Evans Road and Morgan Street	A	8.6	A	7.6
Bernasconi Road and New Street	B	14.4	B	15.4
Bernasconi Road and Ramona Expressway	D	37.1	D	44.7
Bernasconi Road and Orange Avenue	C	26.7	C	32.3
Reservoir Avenue and Martin St	B	17.2	B	16.2
Reservoir Avenue and Ramona Expressway	C	31.5	C	33.0
Reservoir Avenue and 9th Street	B	14.4	B	13.9
Town Center Boulevard and Frontage Rd	B	10.8	B	10.3
Town Center Boulevard and Ramona Expressway	D	48.7	D	43.5
Town Center Boulevard and 5th Street	C	28.1	C	30.2
Park Center Boulevard and Marvin Road	C	31.7	C	29.4
Park Center Boulevard and Ramona Expressway	C	32.6	C	31.3
Park Center Boulevard and New Street	A	6.9	A	7.4
Warren Road and Ramona Expressway	D	39.4	C	32.7
Warren Road and Record Road	B	11.7	B	12.5
Gilman Springs Road and SR 79 Southbound Ramps	B	17.7	C	22.1
Gilman Springs Road and SR 79 Northbound Ramps	C	28.6	C	27.0
Ramona Expressway and SR 79 Southbound Ramps	C	28.0	C	29.7
Ramona Expressway and SR 79 Northbound Ramps	A	7.1	B	15.3
Sanderson Avenue and SR 79 WB Ramps	C	20.1	C	24.8
Sanderson Avenue and SR 79 EB Ramps	A	8.7	A	9.8
Sanderson Avenue and Cottonwood Avenue	D	38.0	D	37.7

Notes:

">80" – Exceeds 80 seconds

Table 7-5
 Horizon Year (2040)
 Freeway and HOV Lane Capacity Analysis (1)
 Interstate 15 - Alternative 4

Northbound		Peak Hour Traffic (veh/hr)				Freeway Mainline and HOV Level of Service (2)							
		AM		PM		Number of Lanes		Freeway Capacity (3)	AM Peak Hour		PM Peak Hour		
		Freeway	HOV	Freeway	HOV	Freeway	HOV		LOS (4)	Density (5)	LOS (4)	Density (5)	
Location	Facility												
I - 15 Mainline													
South of Temescal Canyon Rd	Freeway	7533		7617		4		8690	D	33.4	D	34.0	
South of Temescal Canyon Rd	HOV		2904		2693		2		C	25.0	C	23.2	
Temescal Canyon Rd On Ramp to Weirick Rd Off Ramp	Freeway	7912		7802		4		8690	E	36.4	E	35.5	
Temescal Canyon Rd On Ramp to Weirick Rd Off Ramp	HOV		2904		2693		2		C	25.0	C	23.2	
Weirick Rd On Ramp to Cajalco Rd Off Ramp	Freeway	8688		8369		4		8690	E	44.9	E	41.0	
Weirick Rd On Ramp to Cajalco Rd Off Ramp	HOV		2904		2693		2		C	25.0	C	23.2	
Cajalco Rd On Ramp to El Cerrito Rd Off Ramp	Freeway	9569		8808		4		8690	F	49.6	F	45.6	
Cajalco Rd On Ramp to El Cerrito Rd Off Ramp	HOV		2904		2693		2		C	25.0	C	23.2	
El Cerrito Rd On Ramp to Ontario Ave Off Ramp	Freeway	9191		7854		4		8690	F	47.6	E	35.9	
El Cerrito Rd On Ramp to Ontario Ave Off Ramp	HOV		3600		3600		2		D	32.2	D	32.2	
Ontario Ave On Ramp to Magnolia Ave Off Ramp	Freeway	9330		8056		4		8690	F	48.3	E	37.7	
Ontario Ave On Ramp to Magnolia Ave Off Ramp	HOV		3600		3600		2		D	32.2	D	32.2	
North of Magnolia Ave to SR-91	Freeway	9884		8461		4		8690	F	51.2	E	42.1	
North of Magnolia Ave to SR-91	HOV		3600		3600		2		D	32.2	D	32.2	

(1) Capacity Analysis shown for freeway mainline and HOV lanes. See separate page of Table 7-5 for ramps.

(2) One-lane HOV Lane density and level of service calculated using conditions for two freeway lanes and doubling the peak hour traffic.

(3) Freeway capacity is defined as the capacity at level of service E, expressed in vehicles per hour.

(4) LOS = Level of Service.

(5) Density is expressed in passenger cars/mile/lane. For facilities at level of service F, the density shown is the theoretical density that would occur if all demand could be accommodated.

Table 7-5 (cont.)
Horizon Year (2040)
Ramp Capacity Analysis (1)
Interstate 15 - Alternative 4 Modified

Northbound		Peak Hour Traffic (veh/hr)				Number of Lanes		Ramp Level of Service			
		AM		PM				AM Peak Hour		PM Peak Hour	
Location	Facility	Freeway	Ramp	Freeway	Ramp	Freeway	Ramp	LOS (2)	Density (3)	LOS (2)	Density (3)
I - 15 Mainline											
Temescal Canyon Rd Off Ramp	Diverge	7533	360	7617	495	4	1	D	32.3	D	33.4
Temescal Canyon Rd On Ramp	Merge	7173	739	7122	680	4	1	C	25.1	C	24.9
Weirick Rd Off Ramp	Diverge	7912	324	7802	446	4	1	D	33.7	D	33.9
Weirick Rd On Ramp	Merge	7588	1100	7356	1013	4	1	C	25.8	C	25.4
Cajalco Rd Off Ramp	Diverge	8688	821	8369	1129	4	1	F	45.0	F	45.0
Cajalco Rd EB On Ramp	Merge	7867	616	7240	567	4	1	C	26.8	C	25.3
Cajalco Rd WB On Ramp	Merge	8483	1086	7807	1001	4	1	F	49.6	C	26.3
El Cerrito Rd Off Ramp	Diverge	9569	497	8808	683	4	1	F	47.6	F	45.0
El Cerrito Rd On Ramp	Merge	9072	815	8125	656	4	1	F	47.6	C	27.4
Ontario Ave Off Ramp	Diverge	9191	986	7854	907	4	1	F	42.5	E	36.5
Ontario Ave On Ramp	Merge	8205	1125	6947	1109	4	1	F	48.3	C	24.5
Magnolia Ave Off Ramp	Diverge	9330	1250	8056	1021	4	1	F	48.3	F	45.0
Magnolia Ave EB On Ramp	Merge	8080	1203	7035	951	4	1	F	48.3	C	24.7
Magnolia Ave WB On Ramp	Merge	9283	601	7986	475	4	1	F	48.1	C	27.3

(1) Capacity analysis shown for ramps only. See separate page of Table 7-5 for freeway mainline and HOV lanes.

(2) LOS = Level of Service.

(3) Density is expressed in passenger cars/mile/lane. For facilities at level of service F, the density shown is the theoretical density that would occur if all demand could be accommodated based on capacity of the adjacent freeway segment.

Table 7-5 (cont.)
Horizon Year (2040)
Freeway and HOV Lane Capacity Analysis (1)
Interstate 15 - Alternative 4 Modified

Southbound		Peak Hour Traffic (veh/hr)				Freeway Mainline and HOV Level of Service (2)							
		AM		PM		Number of Lanes		Freeway Capacity (3)	AM Peak Hour		PM Peak Hour		
		Freeway	HOV	Freeway	HOV	Freeway	HOV		LOS (4)	Density (5)	LOS (4)	Density (5)	
Location	Facility												
I - 15 Mainline													
SR-91 to Magnolia Ave	Freeway	9030		10887		4		8690	F	46.8	F	56.4	
SR-91 to Magnolia Ave	HOV		2918		3600		2		C	25.2	D	32.2	
Magnolia Ave On Ramp to Ontario Ave Off Ramp	Freeway	7747		10509		4		8690	D	35.0	F	54.4	
Magnolia Ave On Ramp to Ontario Ave Off Ramp	HOV		2918		3600		2		C	25.2	D	32.2	
Ontario Ave On Ramp to El Cerrito Rd Off Ramp	Freeway	7805		11009		4		8690	E	35.5	F	57.0	
Ontario Ave On Ramp to El Cerrito Rd Off Ramp	HOV		2918		3600		2		C	25.2	D	32.2	
El Cerrito Rd On Ramp to Cajalco Rd Off Ramp	Freeway	7829		10766		4		8690	E	35.7	F	55.8	
El Cerrito Rd On Ramp to Cajalco Rd Off Ramp	HOV		2376		3267		2		C	20.5	D	28.4	
Cajalco Rd On Ramp to Weirick Rd Off Ramp	Freeway	7438		9774		4		8690	D	32.7	F	50.6	
Cajalco Rd On Ramp to Weirick Rd Off Ramp	HOV		2376		3267		2		C	20.5	D	28.4	
Weirick Rd On Ramp to Temescal Canyon Rd Off Ramp	Freeway	6934		8901		4		8690	D	29.5	F	46.1	
Weirick Rd On Ramp to Temescal Canyon Rd Off Ramp	HOV		2376		3267		2		C	20.5	D	28.4	
South of Temescal Canyon Rd	Freeway	6769		8474		4		8690	D	28.6	E	42.2	
South of Temescal Canyon Rd	HOV		2376		3267		2		C	20.5	D	28.4	

(1) Capacity Analysis shown for freeway mainline and HOV lanes. See separate page of Table 7-5 for ramps.

(2) One-lane HOV Lane density and level of service calculated using conditions for two freeway lanes and doubling the peak hour traffic.

(3) Freeway capacity is defined as the capacity at level of service E, expressed in vehicles per hour.

(4) LOS = Level of Service.

(5) Density is expressed in passenger cars/mile/lane. For facilities at level of service F, the density shown is the theoretical density that would occur if all demand could be accommodated.

Table 7-5 (cont.)
Horizon Year (2040)
Ramp Capacity Analysis (1)
Interstate 15 - Alternative 4 Modified

Southbound		Peak Hour Traffic (veh/hr)				Number of Lanes		Ramp Level of Service			
		AM		PM				AM Peak Hour		PM Peak Hour	
Location	Facility	Freeway	Ramp	Freeway	Ramp	Freeway	Ramp	LOS (2)	Density (3)	LOS (2)	Density (3)
I - 15 Mainline											
Magnolia Ave Off Ramp	Diverge	9030	2190	10887	1625	4	1	F	46.8	F	56.4
Magnolia Ave On Ramp	Merge	6840	907	9262	1247	4	1	C	24.3	F	54.4
Ontario Ave Off Ramp	Diverge	7747	1289	10509	942	4	1	F	45.0	F	54.4
Ontario Ave On Ramp	Merge	6458	806	9567	1109	4	1	C	23.4	F	57.0
El Cerrito Rd Off Ramp	Diverge	7805	583	11009	802	4	1	D	34.6	F	57.0
El Cerrito Rd On Ramp	Merge	7222	607	10207	559	4	1	C	25.2	F	55.8
Cajalco Rd Off Ramp	Diverge	7829	1394	10766	1915	4	1	F	45.0	F	55.8
Cajalco Rd On Ramp	Merge	6435	1003	8851	923	4	1	C	23.5	F	50.6
Weirick Rd Off Ramp	Diverge	7438	900	9774	1238	4	1	D	34.8	F	50.6
Weirick Rd On Ramp	Merge	6538	396	8536	365	4	1	C	23.4	F	46.1
Temescal Canyon Rd Off Ramp	Diverge	6934	605	8901	832	4	1	D	31.2	F	46.1
Temescal Canyon Rd On Ramp	Merge	6329	440	8069	405	4	1	C	22.9	C	27.6

(1) Capacity analysis shown for ramps only. See separate page of Table 7-5 for freeway mainline and HOV lanes.

(2) LOS = Level of Service.

(3) Density is expressed in passenger cars/mile/lane.

Table 7-6
Horizon Year (2040)
Freeway and HOV Lane Capacity Analysis (1)
Interstate 215 - Alternative 4 Modified

Northbound		Peak Hour Traffic (veh/hr)				Number of Lanes		Freeway Mainline and HOV Level of Service (2)				
		AM		PM				Freeway Capacity (3)	AM Peak Hour		PM Peak Hour	
		Freeway	HOV	Freeway	HOV				LOS (4)	Density (5)	LOS (4)	Density (5)
Location	Facility											
I - 215 Mainline												
Nuevo Rd On Ramp to Placentia Ave Off Ramp	Freeway	5779		5495		3		6470	D	34.1	D	32.5
Nuevo Rd On Ramp to Placentia Ave Off Ramp	HOV		1800		1800		1	6470	D	32.2	D	32.2
Placentia Ave On Ramp to Mid County Parkway EB Off Ramp	HOV		1800		1800		1	6470	D	32.2	D	32.2
Mid County Parkway EB Off Ramp to Cajalco/Ramona Expwy Off Ramp	Freeway	5672		5149		3		6470	D	34.2	D	29.6
Mid County Parkway EB Off Ramp to Cajalco/Ramona Expwy Off Ramp	HOV		1800		1800		1	6470	D	32.2	D	32.2
Cajalco/Ramona Expwy On Ramp to Mid County Parkway WB On Ramp	Freeway	5826		5219		4		8690	C	23.0	C	20.3
Cajalco/Ramona Expwy On Ramp to Mid County Parkway WB On Ramp	HOV		1800		1800		1	8690	D	32.2	D	32.2
Mid County Parkway WB On Ramp to Harley Knox Blvd Off Ramp	Freeway	8519		7698		5		10930	D	28.3	C	25.0
Mid County Parkway WB On Ramp to Harley Knox Blvd Off Ramp	HOV		1800		1800		1	10930	D	32.2	D	32.2
Harley Knox Blvd On Ramp to Van Buren Blvd Off Ramp	Freeway	8684		7986		4		8690	E	44.9	E	37.1
Harley Knox Blvd On Ramp to Van Buren Blvd Off Ramp	HOV		1800		1800		1	8690	D	32.2	D	32.2
Van Buren Blvd On Ramp to Cactus Ave Off Ramp	Freeway	7959		7181		3		6470	F	55.4	F	49.9
Van Buren Blvd On Ramp to Cactus Ave Off Ramp	HOV		1800		1800		1	6470	D	32.2	D	32.2
Cactus Ave On Ramp to Alessandro Blvd Off Ramp	Freeway	7775		7011		3		6470	F	54.1	F	48.8
Cactus Ave On Ramp to Alessandro Blvd Off Ramp	HOV		1800		1800		1	6470	D	32.2	D	32.2
North of Alessandro Blvd	Freeway	7423		6687		3		6470	F	51.6	F	46.5
North of Alessandro Blvd	HOV		1800		1800		1	6470	D	32.2	D	32.2

(1) Capacity Analysis shown for freeway mainline and HOV lanes. See separate page of Table 7-6 for ramps.

(2) One-lane HOV Lane density and level of service calculated using conditions for two freeway lanes and doubling the peak hour traffic.

(3) Freeway capacity is defined as the capacity at level of service E, expressed in vehicles per hour.

(4) LOS = Level of Service.

(5) Density is expressed in passenger cars/mile/lane. For facilities at level of service F, the density shown is the theoretical density that would occur if all demand could be accommodated.

Table 7-6 (cont.)
Horizon Year (2040)
Ramp Capacity Analysis (1)
Interstate 215 - Alternative 4 Modified

Northbound		Peak Hour Traffic (veh/hr)				Number of Lanes		Ramp Level of Service			
		AM		PM				AM Peak Hour		PM Peak Hour	
Location	Facility	Freeway	Ramp	Freeway	Ramp	Freeway	Ramp	LOS (2)	Density (3)	LOS (2)	Density (3)
I - 215 Mainline											
South of Nuevo Rd	Weave (4)	6679		6906		4		D	31.2	D	31.4
Nuevo Rd Off Ramp	Diverge (5)	6679	540	6906	430	4	2	B	15.6	B	16.4
Nuevo Rd On Ramp	Merge (6)	6139	1440	6476	819	3	1	F	45.0	F	45.0
Placentia Ave Off Ramp	Diverge	5779	613	5495	675	3	1	D	33.1	D	32.0
Placentia Ave On Ramp	Merge	5166	808	4820	745	3	1	D	34.7	D	32.4
Placentia Ave On Ramp to Mid County Parkway EB Off Ramp	Weave	5974		5565		4		C	24.7	C	22.9
Mid County Parkway EB Off Ramp	Diverge	5974	302	5565	416	4	2	D	33.4	D	31.9
Cajalco/Ramona Expwy Off Ramp	Diverge	5672	605	5149	832	3	1	D	32.7	D	30.9
Cajalco/Ramona Expwy On Ramp	Merge	5067	759	4317	902	3	1	D	33.8	D	31.2
Mid County Parkway WB On Ramp	Merge (6)	5826	2693	5219	2479	3	2	F	45.0	F	45.0
Harley Knox Blvd Off Ramp	Diverge	8519	413	7698	514	4	1	E	36.6	D	33.8
Harley Knox Blvd On Ramp	Merge	8106	578	7184	802	4	1	C	27.5	C	25.1
Van Buren Blvd Off Ramp	Diverge	8684	1368	7986	1399	4	2	F	45.0	F	45.0
Van Buren Blvd EB On Ramp	Merge	7316	533	6587	514	3	1	F	55.4	F	49.9
Van Buren Blvd WB On Ramp	Merge	7849	110	7101	80	3	1	F	55.4	F	49.9
Cactus Ave Off Ramp	Diverge	7959	746	7181	942	3	1	F	55.4	F	49.9
Cactus Ave EB On Ramp	Merge	7213	216	6239	297	3	1	F	54.1	E	36.0
Cactus Ave WB On Ramp	Merge	7429	346	6536	475	3	1	F	54.1	F	48.8
Alessandro Blvd Off Ramp	Diverge	7775	1021	7011	940	3	1	F	54.1	F	48.8
Alessandro Blvd On Ramp	Merge	6754	669	6071	616	3	1	F	51.6	F	46.5

(1) Capacity analysis shown for ramps only. See separate page of Table 7-14 for freeway mainline and HOV lanes.

(2) LOS = Level of Service.

(3) Density is expressed in passenger cars/mile/lane.

(4) For weaving volumes, see Figure 7-48c. The ramp to ramp movement was assumed to be zero. Weaving length is 2,000 feet per the I-215 widening project

(5) Ramp capacity analysis shown for information only, since this is technically part of a weaving section.

(6) Level of service and density of downstream freeway assumed since lanes are added to freeway at this location.

Table 7-6 (cont.)
Horizon Year (2040)
Freeway and HOV Lane Capacity Analysis (1)
Interstate 215 - Alternative 4 Modified

Southbound		Peak Hour Traffic (veh/hr)				Freeway Mainline and HOV Level of Service (2)							
		AM		PM		Number of Lanes		Freeway Capacity (3)	AM Peak Hour		PM Peak Hour		
		Freeway	HOV	Freeway	HOV	Freeway	HOV		LOS (4)	Density (5)	LOS (4)	Density (5)	
Location	Facility												
I - 215 Mainline													
North of Alessandro Blvd	Freeway	5743		8577		3		6470	D	34.9	F	59.7	
North of Alessandro Blvd	HOV		1800		1800		1	6470	D	32.2	D	32.2	
Alessandro Blvd On Ramp to Cactus Ave Off Ramp	Freeway	6031		8973		3		6470	E	38.2	F	62.4	
Alessandro Blvd On Ramp to Cactus Ave Off Ramp	HOV		1800		1800		1	6470	D	32.2	D	32.2	
Cactus Ave On Ramp to Van Buren Blvd Off Ramp	Freeway	6183		9181		3		6470	E	40.3	F	63.9	
Cactus Ave On Ramp to Van Buren Blvd Off Ramp	HOV		1800		1800		1	6470	D	32.2	D	32.2	
Van Buren Blvd On Ramp to Harley Knox Blvd Off Ramp	Freeway	6896		9995		4		8690	D	29.3	F	51.8	
Van Buren Blvd On Ramp to Harley Knox Blvd Off Ramp	HOV		1800		1800		1	8690	D	32.2	D	32.2	
Harley Knox Blvd On Ramp to Mid County Parkway EB Off Ramp	HOV		1800		1800		1	8690	D	32.2	D	32.2	
Mid County Parkway EB Off Ramp to Cajalco/Ramona Expwy Off Ramp	Freeway	4440		6780		4		8690	C	18.3	D	28.6	
Mid County Parkway EB Off Ramp to Cajalco/Ramona Expwy Off Ramp	HOV		1800		1800		1	8690	D	32.2	D	32.2	
Cajalco/Ramona Expwy On Ramp to Mid County Parkway WB On Ramp	Freeway	4376		6607		3		6470	C	23.1	E	44.2	
Cajalco/Ramona Expwy On Ramp to Mid County Parkway WB On Ramp	HOV		1800		1800		1	6470	D	32.2	D	32.2	
Mid County Parkway WB On Ramp to Placentia Ave Off Ramp	HOV		1800		1800		1	6470	D	32.2	D	32.2	
Placentia Ave On Ramp to Nuevo Rd Off Ramp	Freeway	4663		6746		3		6470	D	26.3	F	46.9	
Placentia Ave On Ramp to Nuevo Rd Off Ramp	HOV		1800		1800		1	6470	D	32.2	D	32.2	
South of Nuevo Rd	HOV		1800		1800		1	6470	D	32.2	D	32.2	

(1) Capacity Analysis shown for freeway mainline and HOV lanes. See separate page of Table 7-6 for ramps.

(2) One-lane HOV Lane density and level of service calculated using conditions for two freeway lanes and doubling the peak hour traffic.

(3) Freeway capacity is defined as the capacity at level of service E, expressed in vehicles per hour.

(4) LOS = Level of Service.

(5) Density is expressed in passenger cars/mile/lane. For facilities at level of service F, the density shown is the theoretical density that would occur if all demand could be accommodated.

Table 7-6 (cont.)
 Horizon Year (2040)
 Ramp Capacity Analysis (1)
 Interstate 215 - Alternative 4 Modified

Southbound		Peak Hour Traffic (veh/hr)				Number of Lanes		Ramp Level of Service			
		AM		PM				AM Peak Hour		PM Peak Hour	
Location	Facility	Freeway	Ramp	Freeway	Ramp	Freeway	Ramp	LOS (2)	Density (3)	LOS (2)	Density (3)
I - 215 Mainline											
Alessandro Blvd Off Ramp	Diverge	5743	554	8577	752	3	1	D	32.9	F	59.7
Alessandro Blvd WB On Ramp	Merge	5189	254	7825	346	3	1	D	30.4	F	59.7
Alessandro Blvd EB On Ramp	Merge	5443	588	8171	802	3	1	D	34.3	F	62.4
Cactus Ave WB Off Ramp	Diverge	6031	422	8973	389	3	1	D	33.8	F	62.4
Cactus Ave EB Off Ramp	Diverge	5609	264	8584	243	3	1	D	31.9	F	62.4
Cactus Ave On Ramp	Merge	5345	838	8341	840	3	1	E	35.8	F	63.9
Van Buren Blvd Off Ramp	Diverge	6183	526	9181	723	3	1	D	34.6	F	63.9
Van Buren Blvd On Ramp	Merge (4)	5657	1239	8458	1537	3	1	F	48.0	F	51.8
Harley Knox Blvd Off Ramp	Diverge	6896	705	9995	656	4	1	D	31.6	F	51.8
Harley Knox Blvd On Ramp	Merge (4)	6191	452	9339	470	4	1	C	22.5	F	45.0
Harley Knox Blvd On Ramp to Mid County Parkway EB Off Ramp	Weave	6643		9809		4		C	25.1	E	39.1
Mid County Parkway EB Off Ramp	Diverge	6643	2203	9809	3029	4	2	C	22.1	F	45.0
Cajalco/Ramona Expwy Off Ramp	Diverge	4440	803	6780	853	4	1	C	22.1	D	31.9
Cajalco/Ramona Expwy On Ramp	Merge	3637	739	5927	680	3	1	C	26.5	E	37.5
Mid County Parkway WB On Ramp	Merge	4376	370	6607	340	3	1	C	27.2	F	46.0
Mid County Parkway WB On Ramp to Placentia Ave Off Ramp	Weave	4746		6947		4		B	19.6	D	29.6
Placentia Ave Off Ramp	Diverge (5)	4746	635	6947	910	4	2	B	14.0	F	46.0
Placentia Ave On Ramp	Merge	4111	552	6037	709	3	1	C	27.4	F	46.9
Nuevo Rd Off Ramp	Diverge (5)	6463	727	8546	1001	3	1	E	35.9	F	46.9
Nuevo Rd On Ramp	Merge (4)	5736	660	7545	607	3	1	E	36.4	F	46.9
South of Nuevo Rd	Weave	6396		8152		4		D	33.5	F	45.0

(1) Capacity analysis shown for ramps only. See separate page of Table 7-14 for freeway mainline and HOV lanes.

(2) LOS = Level of Service.

(3) Density is expressed in passenger cars/mile/lane.

(4) For weaving volumes, see Figure 7-48c. The ramp to ramp movement was assumed to be zero. Weaving length is 2,000 feet per the I-215 widening project.

(5) Ramp capacity analysis shown for information only, since this is technically part of a weaving section.

(6) Level of service and density of downstream freeway assumed since lanes are added to freeway at this location.

Table 7-7
 Horizon Year (2040)
 Freeway Capacity Analysis (1)
 Mid County Parkway - Alternative 4 Modified

Eastbound		Peak Hour Traffic (veh/hr)				Number of Lanes		Freeway Mainline Level of Service				
		AM		PM				Freeway Capacity (2)	AM Peak Hour		PM Peak Hour	
		Freeway	Ramp	Freeway	Ramp				Freeway	Ramp	LOS (3)	Density (4)
Location	Facility											
Mid County Parkway												
I-215 to Perris Blvd Off Ramp	Freeway	2505		3445		3		6470	B	13.0	B	17.8
Perris Blvd On Ramp to Evans Rd Off Ramp	Freeway	3145		4187		3		6470	B	17.7	C	23.5
Evans Rd On Ramp to Ramona Expwy Off Ramp	Freeway	3017		4134		3		6470	B	15.6	C	21.7
Ramona Expwy On Ramp to Bernasconi Rd Off Ramp	Freeway	3362		4609		3		6470	B	17.4	C	24.7
Bernasconi Rd On Ramp to Reservoir Ave Off Ramp	Freeway	3409		4528		3		6470	B	17.6	C	24.2
Reservoir Ave On Ramp to Town Center Blvd Off Ramp	Freeway	3192		4356		3		6470	B	17.8	C	24.3
Town Center Blvd On Ramp to Park Center Blvd Off Ramp	Freeway	2431		3382		3		6470	B	13.5	C	18.8
Park Center Blvd On Ramp to Warren Rd Off Ramp	Freeway	2697		3496		3		6470	B	15.0	C	19.5
Warren Rd On Ramp to SR-79	Freeway	2136		2937		3		6470	B	11.9	B	16.4

(1) Capacity Analysis shown for freeway mainline. See separate page of Table 7-7 for ramps.

(2) Freeway capacity is defined as the capacity at level of service E, expressed in vehicles per hour.

(3) LOS = Level of Service.

(4) Density is expressed in passenger cars/mile/lane. For facilities at level of service F, the density shown is the theoretical density that would occur if all demand could be accommodated.

Table 7-7 (cont.)
 Horizon Year (2040)
 Ramp Capacity Analysis (1)
 Mid County Parkway - Alternative 4 Modified

Eastbound		Peak Hour Traffic (veh/hr)				Number of Lanes		Ramp Level of Service			
		AM		PM				AM Peak Hour		PM Peak Hour	
Location	Facility	Freeway	Ramp	Freeway	Ramp	Freeway	Ramp	LOS (2)	Density (3)	LOS (2)	Density (3)
Mid County Parkway											
Perris Blvd Off Ramp	Diverge	2505	413	3445	575	3	1	B	16.7	C	22.2
Perris Blvd On Ramp	Merge	2092	1053	2870	1317	3	1	C	21.4	C	24.9
Evans Rd Off Ramp	Diverge	3145	705	4187	823	3	1	C	20.9	C	26.5
Evans Rd On Ramp	Merge	2440	575	3364	919	3	1	B	18.6	C	25.8
Ramona Expwy Off Ramp	Diverge	3017	72	4134	99	3	1	B	19.0	C	24.9
Ramona Expwy On Ramp	Merge	2945	417	4035	574	3	1	C	20.4	C	27.1
Bernasconi Rd Off Ramp	Diverge	3362	274	4609	376	3	1	C	21.2	C	27.6
Bernasconi Rd On Ramp	Merge	3088	321	4233	295	3	1	C	20.4	C	25.9
Reservoir Ave Off Ramp	Diverge	3409	437	4528	450	3	1	C	21.8	C	27.4
Reservoir Ave On Ramp	Merge	2972	220	4078	278	3	1	B	18.8	C	24.8
Town Center Blvd Off Ramp	Diverge	3192	966	4356	1160	3	1	C	21.8	D	28.0
Town Center Blvd On Ramp	Merge	2226	205	3196	186	3	1	B	15.1	B	19.8
Park Center Blvd Off Ramp	Diverge	2431	288	3382	396	3	1	B	16.0	C	21.5
Park Center Blvd On Ramp	Merge	2143	554	2986	510	3	1	B	17.5	C	21.4
Warren Rd Off Ramp	Diverge	2697	807	3496	986	3	1	B	18.7	C	23.4
Warren Rd On Ramp	Merge	1890	246	2510	427	3	1	B	13.5	B	17.8

(1) Capacity analysis shown for ramps only. See separate page of Table 7-7 for freeway mainline.

(2) LOS = Level of Service.

(3) Density is expressed in passenger cars/mile/lane.

Table 7-7 (cont.)
Horizon Year (2040)
Freeway Capacity Analysis (1)
Mid County Parkway - Alternative 4 Modified

Westbound		Peak Hour Traffic (veh/hr)				Number of Lanes		Freeway Mainline Level of Service				
		AM		PM				Capacity (2)	AM Peak Hour		PM Peak Hour	
		Freeway	Ramp	Freeway	Ramp				Freeway	Ramp	LOS (3)	Density (4)
Location	Facility											
Mid County Parkway												
SR-79 to Warren Rd Off Ramp	Freeway	2460		2498		3		6470	B	13.7	B	13.9
Warren Rd On Ramp to Park Center Blvd Off Ramp	Freeway	2971		3140		3		6470	B	16.6	B	17.5
Park Center Blvd On Ramp to Town Center Blvd Off Ramp	Freeway	2869		2840		3		6470	B	16.0	B	15.8
Town Center Blvd On Ramp to Reservoir Ave Off Ramp	Freeway	3841		3635		3		6470	C	21.4	C	20.2
Reservoir Ave On Ramp to Bernasconi Rd Off Ramp	Freeway	4005		3882		3		6470	C	22.3	C	21.6
Bernasconi Rd On Ramp to Ramona Expwy Off Ramp	Freeway	4056		3826		3		6470	C	22.6	C	21.3
Ramona Expwy On Ramp to Evans Rd Off Ramp	Freeway	3633		3437		3		6470	C	20.2	C	19.2
Evans Rd On Ramp to Perris Blvd Off Ramp	Freeway	3818		3547		3		6470	C	21.4	C	19.9
Perris Blvd On Ramp to I-215	Freeway	3063		2819		3		6470	B	17.1	B	15.7

(1) Capacity Analysis shown for freeway mainline. See separate page of Table 7-7 for ramps.

(2) Freeway capacity is defined as the capacity at level of service E, expressed in vehicles per hour.

(3) LOS = Level of Service.

(4) Density is expressed in passenger cars/mile/lane. For facilities at level of service F, the density shown is the theoretical density that would occur if all demand could be accommodated.

Table 7-7 (cont.)
Horizon Year (2040)
Ramp Capacity Analysis (1)
Mid County Parkway - Alternative 4 Modified

Westbound		Peak Hour Traffic (veh/hr)				Number of Lanes		Ramp Level of Service			
		AM		PM				AM Peak Hour		PM Peak Hour	
Location	Facility	Freeway	Ramp	Freeway	Ramp	Freeway	Ramp	LOS (2)	Density (3)	LOS (2)	Density (3)
Mid County Parkway											
Perris Blvd Off Ramp	Diverge	3818	1160	3547	1197	3	1	C	25.4	C	24.2
Perris Blvd On Ramp	Merge	2658	405	2350	469	3	1	B	18.9	B	17.9
Evans Rd Off Ramp	Diverge	3633	684	3437	940	3	1	C	23.4	C	23.0
Evans Rd On Ramp	Merge	2949	869	2497	1050	3	1	C	22.4	C	21.2
Ramona Expwy Off Ramp	Diverge	4056	511	3826	470	3	1	C	25.2	C	24.0
Ramona Expwy On Ramp	Merge	3545	61	3356	81	3	1	C	20.4	B	19.7
Bernasconi Rd Off Ramp	Diverge	4005	283	3882	264	3	1	C	24.5	C	24.1
Bernasconi Rd On Ramp	Merge	3722	334	3618	308	3	1	C	23.7	C	22.4
Reservoir Ave Off Ramp	Diverge	3841	180	3635	248	3	1	C	23.6	C	22.6
Reservoir Ave On Ramp	Merge	3661	344	3387	495	3	1	C	23.4	C	23.3
Town Center Blvd Off Ramp	Diverge	2869	166	2840	228	3	1	B	18.3	B	18.3
Town Center Blvd On Ramp	Merge	2703	1138	2612	1023	3	1	C	25.0	C	23.6
Park Center Blvd Off Ramp	Diverge	2971	454	3140	624	3	1	B	19.4	C	20.7
Park Center Blvd On Ramp	Merge	2517	352	2516	324	3	1	B	17.1	B	17.0
Warren Rd Off Ramp	Diverge	2460	202	2498	277	3	1	B	16.0	B	16.4
Warren Rd On Ramp	Merge	2258	713	2221	919	3	1	B	18.1	B	19.2

(1) Capacity analysis shown for ramps only. See separate page of Table 7-7 for freeway mainline.

(2) LOS = Level of Service.

(3) Density is expressed in passenger cars/mile/lane.

Table 7-8
Horizon Year (2040)
Intersection Capacity Analysis - Alternative 4 Modified
I-15 Area

Intersection	AM Peak Hour		PM Peak Hour	
	LOS	Average Delay (sec)	LOS	Average Delay (sec)
Magnolia Avenue and El Sobrante Road	F	>80.0	F	>80.0
Magnolia Avenue and I-15 Southbound Ramps	F	>80.0	F	>80.0
Magnolia Avenue and I-15 Northbound Ramps	B	18.0	C	23.9
Magnolia Avenue and El Camino Avenue	C	20.1	E	70.8
Ontario Avenue and California Avenue	D	51.0	F	>80.0
Ontario Avenue and I-15 Southbound Ramps	C	23.4	B	15.2
Ontario Avenue and I-15 Northbound Ramps	C	29.3	C	33.3
Ontario Avenue and State Street	B	13.0	B	13.2
El Cerrito Road and Bedford Canyon Road	C	26.7	C	28.0
El Cerrito Road and I-15 Southbound Ramps	B	17.5	C	22.7
El Cerrito Road and I-15 Northbound Ramps	D	35.6	C	20.8
El Cerrito Road and Temescal Canyon Road	C	31.4	C	30.7
Cajalco Road and Bedford Canyon Road	C	20.1	C	30.9
Cajalco Road and I-15 Southbound Ramps	C	24.3	C	24.0
Cajalco Road and I-15 Northbound Ramps	B	10.8	B	15.2
Cajalco Road and Temescal Canyon Road	E	61.2	F	>80.0
Weirick Road and Knabe Road	C	26.7	C	28.7
Weirick Road and I-15 Southbound Ramps	C	22.1	B	16.8
Weirick Road and I-15 Northbound Ramps	A	9.3	B	11.3
Weirick Road and Temescal Canyon Road	C	22.1	C	29.2
Temescal Canyon Road and Lawson Drive	C	20.4	B	18.8
Temescal Canyon Road and I-15 Southbound Ramps	B	15.5	D	38.8
Temescal Canyon Road and I-15 Northbound Ramps	C	22.5	C	24.9

Notes:

">80" – Exceeds 80 seconds

Table 7-8 (cont.)
 Horizon Year (2040)
 Intersection Capacity Analysis - Alternative 4 Modified
 Cajalco Road, I-15 to I-215

Intersection	AM Peak Hour		PM Peak Hour	
	LOS	Average Delay (sec)	LOS	Average Delay (sec)
Eagle Valley Road and Cajalco Road	C	20.3	B	16.6
Lake Matthews Road and Cajalco Road	B	11.2	B	18.0
El Sobrante Road and Cajalco Road	B	19.0	B	16.0
Wood Road and Cajalco Road	C	23.1	C	23.3
Alexander Street and Cajalco Road	C	27.2	C	24.1
Clark Street and Cajalco Road	B	13.7	B	17.3

Notes:

">80" – Exceeds 80 seconds

Table 7-8 (cont.)
Horizon Year (2040)
Intersection Capacity Analysis - Alternative 4 Modified
I-215 Area

Intersection	AM Peak Hour		PM Peak Hour	
	LOS	Average Delay (sec)	LOS	Average Delay (sec)
Alessandro Boulevard and Meridian Parkway	F	>80.0	F	>80.0
Alessandro Boulevard and I-215 Southbound Ramps	D	39.8	F	>80.0
Alessandro Boulevard and I-215 Northbound Ramps	D	50.9	F	>80.0
Alessandro Boulevard and Old I-215	D	51.7	F	>80.0
Cactus Ave and Innovation Dr	D	52.2	F	>80.0
Cactus Ave and I-215 Southbound Ramps	B	17.7	B	18.2
Cactus Ave and I-215 Northbound Ramps	C	27.4	D	53.6
Cactus Ave and Ellsworth St	D	39.8	D	37.2
Van Buren Boulevard and Meridian Parkway	C	29.4	C	23.2
Van Buren Boulevard and I-215 Southbound Ramps	B	12.3	B	16.9
Van Buren Boulevard and I-215 Northbound Ramps	C	31.1	B	20.0
Harley Knox Blvd and Harvill Avenue	C	21.1	C	23.2
Harley Knox Blvd and I-215 Southbound Ramps	B	15.2	B	18.6
Harley Knox Blvd and I-215 Northbound Ramps	B	15.1	B	17.3
Harley Knox Blvd and Western Way	A	8.7	A	8.8
Cajalco Road and Harvill Avenue	D	35.3	D	40.1
Cajalco Road and I-215 Southbound Ramps	B	17.1	B	16.3
Cajalco Road and I-215 Northbound Ramps	B	15.8	B	17.4
Ramona Expressway and Patterson Avenue	A	5.5	A	5.7
Ramona Expressway and Webster Avenue	C	32.7	D	37.1
Placentia Avenue and Harvill Avenue	C	30.8	D	42.0
Placentia Avenue and I-215 Southbound Ramps	B	14.6	B	15.5
Placentia Avenue and I-215 Northbound Ramps	B	17.9	B	19.3
Placentia Avenue and East Frontage Road	C	25.6	C	23.6
Nuevo Road and A Street	B	20.0	C	22.5
Nuevo Road and I-215 Southbound Ramps	C	30.4	C	27.5
Nuevo Road and I-215 Northbound Ramps	C	30.9	B	10.3
Nuevo Road and Old Nuevo Road	C	34.7	D	38.3

Notes:

">80" – Exceeds 80 seconds

Table 7-8 (cont.)
Horizon Year (2040)
Intersection Capacity Analysis - Alternative 4 Modified
Mid County Parkway, I-215 to SR 79

Intersection	AM Peak Hour		PM Peak Hour	
	LOS	Average Delay (sec)	LOS	Average Delay (sec)
Perris Blvd and Markham St	D	35.5	D	48.4
Perris Blvd and MCP Westbound Ramps	C	22.3	C	25.1
Perris Blvd and MCP Eastbound Ramps	A	5.7	A	8.4
Perris Blvd and Ramona Expwy	D	53.7	D	44.2
Evans Road and Old Evans Rd	C	29.2	C	28.0
Evans Road and MCP Westbound Ramps	B	10.5	B	14.3
Evans Road and MCP Eastbound Ramps	B	14.3	B	12.1
Evans Road and Orange Ave	C	34.9	D	40.4
Ramona Expressway and Rider Street	B	18.2	A	8.2
Ramona Expressway and MCP Westbound Ramps	A	9.5	A	5.5
Ramona Expressway and MCP Eastbound Ramps	B	10.8	B	12.7
Ramona Expressway and Orange Ave	C	26.4	D	33.9
Bernasconi Road and New St	B	12.0	B	12.5
Bernasconi Road and MCP Westbound Ramps	B	14.4	B	15.8
Bernasconi Road and MCP Eastbound Ramps	B	14.9	B	17.5
Bernasconi Road and Orange Avenue	C	33.6	D	36.0
Reservoir Avenue and Martin St	C	34.9	D	41.6
Reservoir Avenue and MCP Westbound Ramps	B	18.6	B	18.0
Reservoir Avenue and MCP Eastbound Ramps	A	8.8	A	7.9
Reservoir Avenue and 9th Street	B	19.9	B	19.1
Town Center Boulevard and Frontage Rd	C	32.7	C	34.3
Town Center Boulevard and MCP Westbound Ramps	A	9.0	A	7.7
Town Center Boulevard and MCP Eastbound Ramps	C	23.7	C	20.7
Town Center Boulevard and 5th Street	C	27.7	C	25.9
Park Center Boulevard and Marvin Road	C	33.2	C	28.5
Park Center Boulevard and MCP Westbound Ramps	B	14.3	B	18.3
Park Center Boulevard and MCP Eastbound Ramps	B	13.2	B	12.0
Park Center Boulevard and New Street	A	7.8	A	7.4
Warren Road and Ramona Expressway	C	21.6	B	19.3
Warren Road and MCP Westbound Ramps	A	5.4	A	6.4
Warren Road and MCP Eastbound Ramps	B	11.9	B	11.3
Warren Road and Record Road	B	9.8	B	10.9
Gilman Springs Road and SR 79 Southbound Ramps	B	19.1	B	17.5
Gilman Springs Road and SR 79 Northbound Ramps	B	17.8	C	25.2
Sanderson Ave and MCP	D	46.6	D	42.5
MCP and SR 79	C	22.5	C	28.3
Ramona Expressway and MCP	D	39.0	D	53.2
SR 79 Westbound Ramps and Sanderson Ave	C	24.3	C	26.4
SR 79 Eastbound Ramps and Sanderson Ave	A	9.5	B	12.0
Sanderson Ave and Cottonwood Avenue	D	48.6	D	41.9

Notes:

">80" – Exceeds 80 seconds

Table 7-9
Horizon Year (2040)
Freeway and HOV Lane Capacity Analysis (1)
Interstate 15 - Alternative 5 Modified

Northbound		Peak Hour Traffic (veh/hr)				Number of Lanes		Freeway Mainline and HOV Level of Service (2)				
		AM		PM				Freeway Capacity (3)	AM Peak Hour		PM Peak Hour	
Location	Facility	Freeway	HOV	Freeway	HOV	Freeway	HOV		LOS (4)	Density (5)	LOS (4)	Density (5)
I - 15 Mainline												
South of Temescal Canyon Rd	Freeway	7533		7617		4		8690	D	33.4	D	34.0
South of Temescal Canyon Rd	HOV		2904		2693		2		C	25.0	C	23.2
Temescal Canyon Rd On Ramp to Weirick Rd Off Ramp	Freeway	7912		7802		4		8690	E	36.4	E	35.5
Temescal Canyon Rd On Ramp to Weirick Rd Off Ramp	HOV		2904		2693		2		C	25.0	C	23.2
Weirick Rd On Ramp to Cajalco Rd Off Ramp	Freeway	8688		8369		4		8690	E	44.9	E	41.0
Weirick Rd On Ramp to Cajalco Rd Off Ramp	HOV		2904		2693		2		C	25.0	C	23.2
Cajalco Rd On Ramp to El Cerrito Rd Off Ramp	Freeway	9562		8800		4		8690	F	49.5	F	45.6
Cajalco Rd On Ramp to El Cerrito Rd Off Ramp	HOV		2904		2693		2		C	25.0	C	23.2
El Cerrito Rd On Ramp to Ontario Ave Off Ramp	Freeway	9184		7846		4		8690	F	47.6	E	35.9
El Cerrito Rd On Ramp to Ontario Ave Off Ramp	HOV		3600		3600		2		D	32.2	D	32.2
Ontario Ave On Ramp to Magnolia Ave Off Ramp	Freeway	9323		8048		4		8690	F	48.3	E	37.7
Ontario Ave On Ramp to Magnolia Ave Off Ramp	HOV		3600		3600		2		D	32.2	D	32.2
North of Magnolia Ave to SR-91	Freeway	9877		8453		4		8690	F	51.1	E	42.0
North of Magnolia Ave to SR-91	HOV		3600		3600		2		D	32.2	D	32.2

(1) Capacity Analysis shown for freeway mainline and HOV lanes. See separate page of Table 7-9 for ramps.

(2) One-lane HOV Lane density and level of service calculated using conditions for two freeway lanes and doubling the peak hour traffic.

(3) Freeway capacity is defined as the capacity at level of service E, expressed in vehicles per hour.

(4) LOS = Level of Service.

(5) Density is expressed in passenger cars/mile/lane. For facilities at level of service F, the density shown is the theoretical density that would occur if all demand could be accommodated.

Table 7-9 (cont.)
Horizon Year (2040)
Ramp Capacity Analysis (1)
Interstate 15 - Alternative 5 Modified

Northbound		Peak Hour Traffic (veh/hr)				Number of Lanes		Ramp Level of Service			
		AM		PM				AM Peak Hour		PM Peak Hour	
Location	Facility	Freeway	Ramp	Freeway	Ramp	Freeway	Ramp	LOS (2)	Density (3)	LOS (2)	Density (3)
I - 15 Mainline											
Temescal Canyon Rd Off Ramp	Diverge	7533	360	7617	495	4	1	D	32.3	D	33.4
Temescal Canyon Rd On Ramp	Merge	7173	739	7122	680	4	2	C	25.1	C	24.9
Weirick Rd Off Ramp	Diverge	7912	324	7802	446	4		D	33.7	D	33.9
Weirick Rd On Ramp	Merge	7588	1100	7356	1013	4	2	C	25.8	C	25.4
Cajalco Rd Off Ramp	Diverge	8688	821	8369	1129	4		F	45.0	F	45.0
Cajalco Rd EB On Ramp	Merge	7867	616	7240	567	4	2	C	26.8	C	25.3
Cajalco Rd WB On Ramp	Merge	8483	1079	7807	993	4		F	49.5	C	26.3
El Cerrito Rd Off Ramp	Diverge	9562	497	8800	683	4	2	F	49.5	F	45.6
El Cerrito Rd On Ramp	Merge	9065	815	8117	656	4		F	47.6	C	27.4
Ontario Ave Off Ramp	Diverge	9184	986	7846	907	4	2	F	47.6	E	36.5
Ontario Ave On Ramp	Merge	8198	1125	6939	1109	4		F	48.3	C	24.5
Magnolia Ave Off Ramp	Diverge	9323	1250	8048	1021	4	2	F	48.3	F	45.0
Magnolia Ave EB On Ramp	Merge	8073	1203	7027	951	4		F	51.1	C	24.7
Magnolia Ave WB On Ramp	Merge	9276	601	7978	475	4	2	F	45.0	C	27.3

(1) Capacity analysis shown for ramps only. See separate page of Table 7-9 for freeway mainline and HOV lanes.

(2) LOS = Level of Service.

(3) Density is expressed in passenger cars/mile/lane. For facilities at level of service F, the density shown is the theoretical density that would occur if all demand could be accommodated based on capacity of the adjacent freeway segment.

Table 7-9 (cont.)
Horizon Year (2040)
Freeway and HOV Lane Capacity Analysis (1)
Interstate 15 - Alternative 5 Modified

Southbound		Peak Hour Traffic (veh/hr)				Number of Lanes		Freeway Mainline and HOV Level of Service (2)				
		AM		PM				Freeway Capacity (3)	AM Peak Hour		PM Peak Hour	
Location	Facility	Freeway	HOV	Freeway	HOV	Freeway	HOV		LOS (4)	Density (5)	LOS (4)	Density (5)
I - 15 Mainline												
SR-91 to Magnolia Ave	Freeway	9025		10877		4		8690	F	46.7	F	56.3
SR-91 to Magnolia Ave	HOV		2918		3600		2		C	25.2	D	32.2
Magnolia Ave On Ramp to Ontario Ave Off Ramp	Freeway	7742		10499		4		8690	D	35.0	F	54.4
Magnolia Ave On Ramp to Ontario Ave Off Ramp	HOV		2918		3600		2		C	25.2	D	32.2
Ontario Ave On Ramp to El Cerrito Rd Off Ramp	Freeway	7798		10999		4		8690	E	35.4	F	57.0
Ontario Ave On Ramp to El Cerrito Rd Off Ramp	HOV		2918		3600		2		C	25.2	D	32.2
El Cerrito Rd On Ramp to Cajalco Rd Off Ramp	Freeway	7822		10756		4		8690	E	35.6	F	55.7
El Cerrito Rd On Ramp to Cajalco Rd Off Ramp	HOV		2376		3267		2		C	20.5	D	28.4
Cajalco Rd On Ramp to Weirick Rd Off Ramp	Freeway	7440		9774		4		8690	D	32.7	F	50.6
Cajalco Rd On Ramp to Weirick Rd Off Ramp	HOV		2376		3267		2		C	20.5	D	28.4
Weirick Rd On Ramp to Temescal Canyon Rd Off Ramp	Freeway	6936		8901		4		8690	D	29.5	F	46.1
Weirick Rd On Ramp to Temescal Canyon Rd Off Ramp	HOV		2376		3267		2		C	20.5	D	28.4
South of Temescal Canyon Rd	Freeway	6771		8474		4		8690	D	28.6	E	42.2
South of Temescal Canyon Rd	HOV		2376		3267		2		C	20.5	D	28.4

(1) Capacity Analysis shown for freeway mainline and HOV lanes. See separate page of Table 7-9 for ramps.

(2) One-lane HOV Lane density and level of service calculated using conditions for two freeway lanes and doubling the peak hour traffic.

(3) Freeway capacity is defined as the capacity at level of service E, expressed in vehicles per hour.

(4) LOS = Level of Service.

(5) Density is expressed in passenger cars/mile/lane. For facilities at level of service F, the density shown is the theoretical density that would occur if all demand could be accommodated.

Table 7-9 (cont.)
Horizon Year (2040)
Ramp Capacity Analysis (1)
Interstate 15 - Alternative 5 Modified

Southbound		Peak Hour Traffic (veh/hr)				Number of Lanes		Ramp Level of Service			
		AM		PM				AM Peak Hour		PM Peak Hour	
Location	Facility	Freeway	Ramp	Freeway	Ramp	Freeway	Ramp	LOS (2)	Density (3)	LOS (2)	Density (3)
I - 15 Mainline											
Magnolia Ave Off Ramp	Diverge	9025	2190	10877	1625	4	1	F	46.7	F	56.3
Magnolia Ave On Ramp	Merge	6835	907	9252	1247	4	1	C	24.3	F	54.4
Ontario Ave Off Ramp	Diverge	7742	1289	10499	942	4	1	F	45.0	F	54.4
Ontario Ave On Ramp	Merge	6453	806	9557	1109	4	1	C	23.4	F	57.0
El Cerrito Rd Off Ramp	Diverge	7798	583	10999	802	4	1	D	34.6	F	57.0
El Cerrito Rd On Ramp	Merge	7215	607	10197	559	4	1	C	25.2	F	55.7
Cajalco Rd Off Ramp	Diverge	7822	1385	10756	1905	4	1	F	45.0	F	55.7
Cajalco Rd On Ramp	Merge	6437	1003	8851	923	4	1	C	23.5	F	50.6
Weirick Rd Off Ramp	Diverge	7440	900	9774	1238	4	1	D	34.8	F	50.6
Weirick Rd On Ramp	Merge	6540	396	8536	365	4	1	C	23.4	F	46.1
Temescal Canyon Rd Off Ramp	Diverge	6936	605	8901	832	4	1	D	31.2	F	46.1
Temescal Canyon Rd On Ramp	Merge	6331	440	8069	405	4	1	C	22.9	C	27.6

(1) Capacity analysis shown for ramps only. See separate page of Table 7-9 for freeway mainline and HOV lanes.

(2) LOS = Level of Service.

(3) Density is expressed in passenger cars/mile/lane. For facilities at level of service F, the density shown is the theoretical density that

Table 7-10
Horizon Year (2040)
Freeway and HOV Lane Capacity Analysis (1)
Interstate 215 - Alternative 5 Modified

Northbound		Peak Hour Traffic (veh/hr)				Freeway Mainline and HOV Level of Service (2)							
		AM		PM		Number of Lanes		Freeway Capacity (3)	AM Peak Hour		PM Peak Hour		
		Freeway	HOV	Freeway	HOV	Freeway	HOV		LOS (4)	Density (5)	LOS (4)	Density (5)	
Location	Facility												
I - 215 Mainline													
Nuevo Rd On Ramp to Placentia Ave Off Ramp	Freeway	5896		5563		3		6470	E	37.9	D	34.1	
Nuevo Rd On Ramp to Placentia Ave Off Ramp	HOV		1800		1800		1	6470	D	32.2	D	32.2	
Placentia Ave Off Ramp to Mid County Parkway EB Off Ramp	Freeway	5376		4990		3		6470	D	32.3	D	29.2	
Placentia Ave Off Ramp to Mid County Parkway EB Off Ramp	HOV		1800		1800		1	6470	D	32.2	D	32.2	
Placentia Ave On Ramp to Cajalco/Ramona Expwy Off Ramp	HOV		1800		1800		1	6470	D	32.2	D	32.2	
Mid County Parkway WB On Ramp to Cajalco/Ramona Expwy On Ramp	Freeway	8141		7080		4		8690	E	40.2	D	31.2	
Mid County Parkway WB On Ramp to Cajalco/Ramona Expwy On Ramp	HOV		1800		1800		1	8690	D	32.2	D	32.2	
Harley Knox Blvd On Ramp to Van Buren Blvd Off Ramp	Freeway	8776		8077		4		8690	F	45.4	E	37.9	
Harley Knox Blvd On Ramp to Van Buren Blvd Off Ramp	HOV		1800		1800		1	8690	D	32.2	D	32.2	
Cajalco/Ramona Expwy On Ramp to Harley Knox Blvd Off Ramp	Freeway	8637		7807		4		8690	E	44.3	E	35.5	
Cajalco/Ramona Expwy On Ramp to Harley Knox Blvd Off Ramp	HOV		1800		1800		1	8690	D	32.2	D	32.2	
Van Buren Blvd On Ramp to Cactus Ave Off Ramp	Freeway	8003		7220		3		6470	F	55.7	F	50.2	
Van Buren Blvd On Ramp to Cactus Ave Off Ramp	HOV		1800		1800		1	6470	D	32.2	D	32.2	
Cactus Ave On Ramp to Alessandro Blvd Off Ramp	Freeway	7819		7050		3		6470	F	54.4	F	49.0	
Cactus Ave On Ramp to Alessandro Blvd Off Ramp	HOV		1800		1800		1	6470	D	32.2	D	32.2	
North of Alessandro Blvd	Freeway	7467		6726		3		6470	F	51.9	F	46.8	
North of Alessandro Blvd	HOV		1800		1800		1	6470	D	32.2	D	32.2	

(1) Capacity Analysis shown for freeway mainline and HOV lanes. See separate page of Table 7-10 for ramps.

(2) One-lane HOV Lane density and level of service calculated using conditions for two freeway lanes and doubling the peak hour traffic.

(3) Freeway capacity is defined as the capacity at level of service E, expressed in vehicles per hour.

(4) LOS = Level of Service.

(5) Density is expressed in passenger cars/mile/lane. For facilities at level of service F, the density shown is the theoretical density that would occur if all demand could be accommodated.

(6) For weaving volumes, see Figure 7-26c. The ramp to ramp movement was assumed to be zero. Weaving length is 2,000 feet per the I-215 widening project.

Table 7-10 (cont.)
Horizon Year (2040)
Ramp Capacity Analysis (1)
Interstate 215 - Alternative 5 Modified

Northbound		Peak Hour Traffic (veh/hr)				Number of Lanes		Ramp Level of Service			
		AM		PM				AM Peak Hour		PM Peak Hour	
Location	Facility	Freeway	Ramp	Freeway	Ramp	Freeway	Ramp	LOS (2)	Density (3)	LOS (2)	Density (3)
I - 215 Mainline											
South of Nuevo Rd	Weave (6)	5488		5813		4		E	36.2	E	36.1
Nuevo Rd Off Ramp	Diverge	6632	475	6866	379	4	2	B	10.5	B	10.4
Nuevo Rd On Ramp	Merge	6157	1539	6487	876	3	1	F	45.0	F	45.0
Placentia Ave Off Ramp	Diverge	5896	520	5563	573	3	1	D	33.9	D	32.6
Mid County Parkway EB Off Ramp	Diverge	5376	316	4990	436	3	2	B	15.4	B	14.4
Placentia Ave On Ramp to Cajalco/Ramona Expwy Off Ramp	Weave (6)	5131		4309		4		F	45.0	F	45.0
Placentia Ave On Ramp	Merge	5060	755	4554	696	3	1	C	24.1	D	31.3
Cajalco/Ramona Expwy Off Ramp	Diverge	5815	684	5250	941	3	2	B	19.3	B	18.2
Mid County Parkway WB On Ramp	Merge	5131	3010	4309	2771	3	2	F	45.0	F	45.0
Cajalco/Ramona Expwy On Ramp	Merge	8141	496	7080	727	4	1	D	28.1	C	25.2
Harley Knox Blvd Off Ramp	Diverge	8637	443	7807	552	4	1	F	45.0	E	39.5
Harley Knox Blvd On Ramp	Merge	8194	582	7255	822	4	1	F	45.0	E	35.1
Van Buren Blvd Off Ramp	Diverge	8776	1441	8077	1474	4	2	C	22.6	C	21.1
Van Buren Blvd EB On Ramp	Merge	7335	552	6603	533	3	1	F	55.7	F	50.2
Van Buren Blvd WB On Ramp	Merge	7887	116	7136	84	3	1	F	55.7	F	50.2
Cactus Ave Off Ramp	Diverge	8003	746	7220	942	3	1	F	55.7	F	50.2
Cactus Ave EB On Ramp	Merge	7257	216	6278	297	3	1	F	54.4	E	36.2
Cactus Ave WB On Ramp	Merge	7473	346	6575	475	3	1	F	54.4	F	49.0
Alessandro Blvd Off Ramp	Diverge	7819	1021	7050	940	3	1	F	54.4	F	49.0
Alessandro Blvd On Ramp	Merge	6798	669	6110	616	3	1	F	45.0	F	45.0

(1) Capacity analysis shown for ramps only. See separate page of Table 7-10 for freeway mainline and HOV lanes.

(2) LOS = Level of Service.

(3) Density is expressed in passenger cars/mile/lane. For facilities at level of service F, the density shown is the theoretical density that would occur if all demand could be accommodated based on capacity of the adjacent freeway segment.

Table 7-10 (cont.)
Horizon Year (2040)
Freeway and HOV Lane Capacity Analysis (1)
Interstate 215 - Alternative 5 Modified

Southbound		Peak Hour Traffic (veh/hr)				Number of Lanes		Freeway Mainline and HOV Level of Service (2)					
		AM		PM				Freeway Capacity (3)	AM Peak Hour		PM Peak Hour		
		Freeway	HOV	Freeway	HOV				LOS (4)	Density (5)	LOS (4)	Density (5)	
Location	Facility												
I - 215 Mainline													
North of Alessandro Blvd	Freeway	5777		8628		3		6470	E	36.5	F	60.0	
North of Alessandro Blvd	HOV		1800		1800		1	6470	D	32.2	D	32.2	
Alessandro Blvd On Ramp to Cactus Ave Off Ramp	Freeway	6065		9024		3		6470	E	40.3	F	62.8	
Alessandro Blvd On Ramp to Cactus Ave Off Ramp	HOV		1800		1800		1	6470	D	32.2	D	32.2	
Cactus Ave On Ramp to Van Buren Blvd Off Ramp	Freeway	6217		9232		3		6470	E	42.6	F	64.2	
Cactus Ave On Ramp to Van Buren Blvd Off Ramp	HOV		1800		1800		1	6470	D	32.2	D	32.2	
Van Buren Blvd On Ramp to Harley Knox Blvd Off Ramp	Freeway	6974		10098		4		8690	D	30.5	F	52.3	
Van Buren Blvd On Ramp to Harley Knox Blvd Off Ramp	HOV		1800		1800		1	8690	D	32.2	D	32.2	
Harley Knox Blvd On Ramp to Cajalco/Ramona Expwy Off Ramp	Freeway	6739		9941		4		8690	D	29.1	F	51.5	
Harley Knox Blvd On Ramp to Cajalco/Ramona Expwy Off Ramp	HOV		1800		1800		1	8690	D	32.2	D	32.2	
Cajalco/Ramona Expwy On Ramp to Placentia Ave Off Ramp	Freeway	4505		6724		4		8690	C	18.5	D	28.3	
Cajalco/Ramona Expwy On Ramp to Placentia Ave Off Ramp	HOV		1800		1800		1	8690	D	32.2	D	32.2	
Placentia Ave On Ramp to Nuevo Rd Off Ramp	Freeway	4767		6831		3		6470	D	27.6	F	47.5	
Placentia Ave On Ramp to Nuevo Rd Off Ramp	HOV		1800		1800		1	6470	D	32.2	D	32.2	

- (1) Capacity Analysis shown for freeway mainline and HOV lanes. See separate page of Table 7-10 for ramps.
- (2) One-lane HOV Lane density and level of service calculated using conditions for two freeway lanes and doubling the peak hour traffic.
- (3) Freeway capacity is defined as the capacity at level of service E, expressed in vehicles per hour.
- (4) LOS = Level of Service.
- (5) Density is expressed in passenger cars/mile/lane. For facilities at level of service F, the density shown is the theoretical density that would occur if all demand could be accommodated.
- (6) For weaving volumes, see Figure 7-26c. The ramp to ramp movement was assumed to be zero. Weaving length is 2,000 feet per the I-215 widening project.

Table 7-10 (cont.)
Horizon Year (2040)
Ramp Capacity Analysis (1)
Interstate 215 - Alternative 5 Modified

Southbound		Peak Hour Traffic (veh/hr)				Number of Lanes		Ramp Level of Service			
		AM		PM				AM Peak Hour		PM Peak Hour	
Location	Facility	Freeway	Ramp	Freeway	Ramp	Freeway	Ramp	LOS (2)	Density (3)	LOS (2)	Density (3)
I - 215 Mainline											
Alessandro Blvd Off Ramp	Diverge	5777	554	8628	752	3	1	D	33.0	F	60.0
Alessandro Blvd WB On Ramp	Merge	5223	254	7876	346	3	1	D	30.5	F	62.8
Alessandro Blvd EB On Ramp	Merge	5477	588	8222	802	3	1	D	34.5	F	62.8
Cactus Ave WB Off Ramp	Diverge	6065	422	9024	389	3	1	D	34.0	F	62.8
Cactus Ave EB Off Ramp	Diverge	5643	264	8635	243	3	1	D	32.0	F	62.8
Cactus Ave On Ramp	Merge	5379	838	8392	840	3	1	E	36.0	F	64.2
Van Buren Blvd Off Ramp	Diverge	6217	548	9232	753	3	1	D	34.7	F	64.2
Van Buren Blvd On Ramp	Merge	5669	1305	8479	1619	3	1	F	45.0	F	52.3
Harley Knox Blvd Off Ramp	Diverge	6974	720	10098	662	4	1	D	32.0	F	52.3
Harley Knox Blvd On Ramp	Merge	6254	485	9436	505	4	1	C	22.7	F	51.5
Cajalco/Ramona Expwy Off Ramp	Diverge	6739	606	9941	600	4	1	D	30.4	E	35.3
Mid County Parkway EB Off Ramp	Diverge	6133	2464	9341	3386	4	2	C	22.7	F	45.0
Cajalco/Ramona Expwy On Ramp	Merge	3669	836	5955	769	4	1	B	17.2	C	22.2
Placentia Ave Off Ramp	Diverge	4505	594	6724	851	4	1	C	21.2	D	31.6
Mid County Parkway WB On Ramp	Merge	3911	388	5873	356	3	1	B	17.6	C	26.5
Placentia Ave On Ramp	Merge	4299	468	6229	602	3	1	C	27.6	F	47.5
Nuevo Rd Off Ramp	Diverge	6567	778	8631	1070	3	1	E	36.4	F	47.5
Nuevo Rd On Ramp	Merge	5789	581	7561	534	3	1	E	36.0	F	45.0
South of Nuevo Rd	Weave (6)	5789		7561		4		E	36.9	F	45.0

(1) Capacity analysis shown for ramps only. See separate page of Table 7-10 for freeway mainline and HOV lanes.

(2) LOS = Level of Service.

(3) Density is expressed in passenger cars/mile/lane.

Table 7-11
 Horizon Year (2040)
 Freeway Capacity Analysis (1)
 Mid County Parkway - Alternative 5 Modified

Eastbound		Peak Hour Traffic (veh/hr)		Number of Lanes	Freeway Mainline Level of Service				
					Freeway Capacity (2)	AM Peak Hour		PM Peak Hour	
Location	Facility	AM	PM			LOS (3)	Density (4)	LOS (3)	Density (4)
Mid County Parkway									
I-215 to Perris Blvd Off Ramp	Freeway	2780	3822	3	6470	B	15.6	C	21.5
Perris Blvd On Ramp to Evans Rd Off Ramp	Freeway	3002	4127	3	6470	B	16.9	C	23.2
Evans Rd On Ramp to Ramona Expwy Off Ramp	Freeway	2986	4105	3	6470	B	16.8	C	23.0
Ramona Expwy On Ramp to Bernasconi Rd Off Ramp	Freeway	3367	4628	3	6470	C	18.9	D	26.1
Bernasconi Rd On Ramp to Reservoir Ave Off Ramp	Freeway	3414	4547	3	6470	C	19.2	C	25.6
Reservoir Ave On Ramp to Town Center Blvd Off Ramp	Freeway	3287	4254	3	6470	C	18.4	C	23.9
Town Center Blvd On Ramp to Park Center Blvd Off Ramp	Freeway	2599	3207	3	6470	B	14.6	B	18.0
Park Center Blvd On Ramp to Warren Rd Off Ramp	Freeway	2859	3310	3	6470	B	16.0	C	18.6
Warren Rd On Ramp to SR-79	Freeway	2149	2570	3	6470	B	12.1	B	14.4

(1) Capacity Analysis shown for freeway mainline and HOV lanes. See separate page of Table 7-11 for ramps.

(2) Freeway capacity is defined as the capacity at level of service E, expressed in vehicles per hour.

(3) LOS = Level of Service.

(4) Density is expressed in passenger cars/mile/lane. For facilities at level of service F, the density shown is the theoretical density that would occur if all demand could be accommodated.

Table 7-11
Horizon Year (2040)
Ramp Capacity Analysis (1)
Mid County Parkway - Alternative 5 Modified

Eastbound		Peak Hour Traffic (veh/hr)				Number of Lanes		Ramp Level of Service			
		AM		PM				AM Peak Hour		PM Peak Hour	
Location	Facility	Freeway	Ramp	Freeway	Ramp	Freeway	Ramp	LOS (2)	Density (3)	LOS (2)	Density (3)
Mid County Parkway											
Perris Blvd Off Ramp	Diverge	2780	515	3822	708	3	1	B	18.5	C	24.4
Perris Blvd On Ramp	Merge	2265	737	3114	1013	3	1	B	19.6	C	26.0
Evans Rd Off Ramp	Diverge	3002	634	4127	871	3	1	B	20.0	C	26.3
Evans Rd On Ramp	Merge	2368	618	3256	849	3	1	B	19.1	C	25.4
Ramona Expwy Off Ramp	Diverge	2986	158	4105	218	3	1	B	19.0	C	24.9
Ramona Expwy On Ramp	Merge	2828	539	3887	741	3	1	C	20.8	C	27.7
Bernasconi Rd Off Ramp	Diverge	3367	274	4628	376	3	1	C	21.2	C	27.7
Bernasconi Rd On Ramp	Merge	3093	321	4252	295	3	1	C	20.4	C	26.0
Reservoir Ave Off Ramp	Diverge	3414	388	4547	534	3	1	C	21.7	C	27.6
Reservoir Ave On Ramp	Merge	3026	261	4013	241	3	1	B	19.6	C	24.4
Town Center Blvd Off Ramp	Diverge	3287	911	4254	1252	3	1	C	22.1	C	27.8
Town Center Blvd On Ramp	Merge	2376	223	3002	205	3	1	B	16.0	B	19.0
Park Center Blvd Off Ramp	Diverge	2599	301	3207	414	3	1	B	17.0	C	20.6
Park Center Blvd On Ramp	Merge	2298	561	2793	517	3	1	B	18.3	C	20.5
Warren Rd Off Ramp	Diverge	2859	956	3310	1167	3	1	B	20.0	C	22.9
Warren Rd On Ramp	Merge	1903	246	2143	427	3	1	B	13.8	B	16.5

(1) Capacity analysis shown for ramps only. See separate page of Table 7-11 for freeway mainline.

(2) LOS = Level of Service.

(3) Density is expressed in passenger cars/mile/lane.

Table 7-11 (cont.)
 Horizon Year (2040)
 Freeway Capacity Analysis (1)
 Mid County Parkway - Alternative 5 Modified

Westbound		Peak Hour Traffic (veh/hr)			Number of Lanes	Freeway Mainline Level of Service			
						Capacity (1)	AM Peak Hour		PM Peak Hour
Location	Facility	AM	PM		LOS (2)		Density (3)	LOS (2)	Density (3)
Mid County Parkway									
SR-79 to Warren Rd Off Ramp	Freeway	2321	2407	3	6470	B	13.0	B	13.5
Warren Rd On Ramp to Park Center Blvd Off Ramp	Freeway	2963	3218	3	6470	B	16.6	C	18.1
Park Center Blvd On Ramp to Town Center Blvd Off Ramp	Freeway	2872	2925	3	6470	B	16.1	B	16.4
Town Center Blvd On Ramp to Reservoir Ave Off Ramp	Freeway	3803	3700	3	6470	C	21.3	C	20.8
Reservoir Ave On Ramp to Bernasconi Rd Off Ramp	Freeway	4063	3843	3	6470	C	22.8	C	21.6
Bernasconi Rd On Ramp to Ramona Expwy Off Ramp	Freeway	4114	3787	3	6470	C	23.1	C	21.3
Ramona Expwy On Ramp to Evans Rd Off Ramp	Freeway	3650	3359	3	6470	C	20.5	C	18.9
Evans Rd On Ramp to Perris Blvd Off Ramp	Freeway	3669	3377	3	6470	C	20.6	C	19.0
Perris Blvd On Ramp to I-215	Freeway	3398	3127	3	6470	C	19.1	B	17.6

(1) Capacity Analysis shown for freeway mainline and HOV lanes. See separate page of Table 7-11 for ramps.

(2) One-lane HOV Lane density and level of service calculated using conditions for two freeway lanes and doubling the peak hour traffic.

(3) Freeway capacity is defined as the capacity at level of service E, expressed in vehicles per hour.

(4) LOS = Level of Service.

(5) Density is expressed in passenger cars/mile/lane. For facilities at level of service F, the density shown is the theoretical density that would occur if all demand could be accommodated.

Table 7-11 (cont.)
 Horizon Year (2040)
 Ramp Capacity Analysis (1)
 Mid County Parkway - Alternative 5 Modified

Westbound		Peak Hour Traffic (veh/hr)				Number of Lanes		Ramp Level of Service			
		AM		PM				AM Peak Hour		PM Peak Hour	
Location	Facility	Freeway	Ramp	Freeway	Ramp	Freeway	Ramp	LOS (2)	Density (3)	LOS (2)	Density (3)
Mid County Parkway											
Warren Rd Off Ramp	Diverge	2321	202	2407	277	3	1	B	15.2	B	15.9
Warren Rd On Ramp	Merge	2119	844	2130	1088	3	1	B	19.7	C	21.7
Park Center Blvd Off Ramp	Diverge	2963	459	3218	632	3	1	B	19.4	C	21.1
Park Center Blvd On Ramp	Merge	2504	368	2586	339	3	1	B	17.8	B	18.0
Town Center Blvd Off Ramp	Diverge	2872	182	2925	250	3	1	B	18.4	B	18.8
Town Center Blvd On Ramp	Merge	2690	1113	2675	1025	3	1	C	24.7	C	23.9
Reservoir Ave Off Ramp	Diverge	3803	214	3700	294	3	1	C	23.4	C	23.0
Reservoir Ave On Ramp	Merge	3589	474	3406	437	3	1	C	24.1	C	22.9
Bernasconi Rd Off Ramp	Diverge	4063	283	3843	364	3	1	C	24.8	C	23.9
Bernasconi Rd On Ramp	Merge	3780	334	3479	308	3	1	C	24.0	C	22.2
Ramona Expwy Off Ramp	Diverge	4114	658	3787	606	3	1	C	25.8	C	24.0
Ramona Expwy On Ramp	Merge	3456	194	3181	178	3	1	C	21.2	B	19.7
Evans Rd Off Ramp	Diverge	3650	755	3359	695	3	1	C	23.7	C	22.0
Evans Rd On Ramp	Merge	2895	774	2664	713	3	1	C	23.0	C	21.4
Perris Blvd Off Ramp	Diverge	3669	900	3377	829	3	1	C	24.1	C	22.4
Perris Blvd On Ramp	Merge	2769	629	2548	579	3	1	C	21.2	B	19.7

(1) Capacity analysis shown for ramps only. See separate page of Table 7-11 for freeway mainline and HOV lanes.

(2) LOS = Level of Service.

(3) Density is expressed in passenger cars/mile/lane.

Table 7-12
Horizon Year (2040)
Intersection Capacity Analysis - Alternative 5 Modified
I-15 Area

Intersection	AM Peak Hour		PM Peak Hour	
	LOS	Average Delay (sec)	LOS	Average Delay (sec)
Magnolia Avenue and El Sobrante Road	F	>80.0	F	>80.0
Magnolia Avenue and I-15 Southbound Ramps	F	>80.0	F	>80.0
Magnolia Avenue and I-15 Northbound Ramps	B	18.0	C	23.9
Magnolia Avenue and El Camino Avenue	C	20.1	E	70.8
Ontario Avenue and California Avenue	D	51.0	F	>80.0
Ontario Avenue and I-15 Southbound Ramps	C	23.4	B	15.2
Ontario Avenue and I-15 Northbound Ramps	C	29.3	C	33.3
Ontario Avenue and State Street	B	13.0	B	13.2
El Cerrito Road and Bedford Canyon Road	C	26.7	C	28.0
El Cerrito Road and I-15 Southbound Ramps	B	17.5	C	22.7
El Cerrito Road and I-15 Northbound Ramps	D	35.6	C	20.8
El Cerrito Road and Temescal Canyon Road	C	31.4	C	30.7
Cajalco Road and Bedford Canyon Road	C	20.2	C	31.0
Cajalco Road and I-15 Southbound Ramps	C	24.3	C	23.9
Cajalco Road and I-15 Northbound Ramps	B	10.8	B	15.2
Cajalco Road and Temescal Canyon Road	E	60.1	F	>80.0
Weirick Road and Knabe Road	C	26.7	C	28.7
Weirick Road and I-15 Southbound Ramps	C	22.1	B	16.8
Weirick Road and I-15 Northbound Ramps	A	9.3	B	11.3
Weirick Road and Temescal Canyon Road	C	22.1	C	29.2
Temescal Canyon Road and Lawson Drive	C	20.4	B	18.8
Temescal Canyon Road and I-15 Southbound Ramps	B	15.5	D	38.8
Temescal Canyon Road and I-15 Northbound Ramps	C	22.5	C	24.9

Notes:

">80" – Exceeds 80 seconds

Table 7-12 (cont.)
 Horizon Year (2040)
 Intersection Capacity Analysis - Alternative 5 Modified
 Cajalco Road, I-15 to I-215

Intersection	AM Peak Hour		PM Peak Hour	
	LOS	Average Delay (sec)	LOS	Average Delay (sec)
Eagle Valley Rd and Cajalco Road	C	21.7	B	16.6
Lake Matthews Road and Cajalco Road	B	12.3	B	18.1
El Sobrante Road and Cajalco Road	B	18.9	B	16.1
Wood Road and Cajalco Road	C	22.9	C	24.8
Alexander Street and Cajalco Road	C	25.8	B	18.7
Clark Street and Cajalco Road	B	13.1	B	18.0

Notes:

">80" – Exceeds 80 seconds

Table 7-12 (cont.)
Horizon Year (2040)
Intersection Capacity Analysis - Alternative 5 Modified
I-215 Area

Intersection	AM Peak Hour		PM Peak Hour	
	LOS	Average Delay (sec)	LOS	Average Delay (sec)
Alessandro Blvd and Meridian Parkway	F	>80.0	F	>80.0
Alessandro Blvd and I-215 Southbound Ramps	D	38.4	F	>80.0
Alessandro Blvd and I-215 Northbound Ramps	D	51.7	F	>80.0
Alessandro Blvd and Valley Springs Parkway	D	50.5	F	>80.0
Cactus Avenue and Innovation Drive	D	53.7	F	>80.0
Cactus Avenue and I-215 Southbound Ramps	B	17.4	B	18.2
Cactus Avenue and I-215 Northbound Ramps	C	27.9	D	54.1
Cactus Avenue and Ellsworth Street	D	39.9	D	37.3
Van Buren Boulevard and Meridian Parkway	C	30.6	C	24.5
Van Buren Boulevard and I-215 Southbound Ramps	B	13.0	B	17.7
Van Buren Boulevard and I-215 Northbound Ramps	C	20.1	C	20.4
Harley Knox Blvd and Harvill Avenue	C	21.1	C	23.0
Harley Knox Blvd and I-215 Southbound Ramps	B	15.7	B	19.1
Harley Knox Blvd and I-215 Northbound Ramps	B	16.1	B	18.1
Harley Knox Blvd and Western Way	A	8.7	A	9.0
Cajalco Road and Harvill Avenue	D	37.9	D	35.7
Cajalco Road and I-215 Southbound Ramps	B	14.7	B	13.6
Cajalco Road and I-215 Northbound Ramps	B	15.4	B	17.3
Ramona Expressway and Patterson Avenue	B	15.0	C	20.3
Ramona Expressway and Webster Avenue	C	31.8	C	30.6
Placentia Avenue and Harvill Avenue	C	33.1	D	36.9
Placentia Avenue and I-215 Southbound Ramps	B	17.7	B	18.9
Placentia Avenue and I-215 Northbound Ramps	B	15.8	B	17.1
Placentia Avenue and East Frontage Road	A	9.7	A	8.6
Nuevo Road and A Street	B	17.8	B	17.3
Nuevo Road and I-215 Southbound Ramps	C	29.9	C	24.3
Nuevo Road and I-215 Northbound Ramps	D	39.6	B	10.2
Nuevo Road and Old Nuevo Road	D	25.4	D	40.8

Notes:

">80" – Exceeds 80 seconds

Table 7-12 (cont.)
Horizon Year (2040)
Intersection Capacity Analysis - Alternative 5 Modified
Mid County Parkway, I-215 to SR 79

Intersection	AM Peak Hour		PM Peak Hour	
	LOS	Average Delay (sec)	LOS	Average Delay (sec)
Perris Blvd and Morgan St	C	30.8	D	54.6
Perris Blvd and MCP Westbound Ramps	C	20.0	B	18.3
Perris Blvd and MCP Eastbound Ramps	D	48.6	D	52.4
Perris Blvd and Placentia Ave	C	28.9	C	31.9
Evans Road and Rider Street	C	28.6	C	25.9
Evans Road and MCP Westbound Ramps	B	11.4	B	10.6
Evans Road and MCP Eastbound Ramps	B	13.6	B	12.6
Evans Road and Orange Ave	C	34.2	D	41.5
Ramona Expressway and Rider Street	B	18.8	A	8.2
Ramona Expressway and MCP Westbound Ramps	B	10.4	A	7.0
Ramona Expressway and MCP Eastbound Ramps	B	12.6	B	17.1
Ramona Expressway and Orange Ave	C	28.2	C	35.3
Bernasconi Road and New St	B	11.3	B	12.7
Bernasconi Road and MCP Westbound Ramps	B	15.2	B	13.9
Bernasconi Road and MCP Eastbound Ramps	B	14.9	B	12.7
Bernasconi Road and Orange Avenue	C	33.3	D	35.6
Reservoir Avenue and Martin St	D	37.8	D	41.3
Reservoir Avenue and MCP Westbound Ramps	C	22.7	C	20.3
Reservoir Avenue and MCP Eastbound Ramps	A	5.9	B	11.5
Reservoir Avenue and 9th Street	B	14.1	B	13.0
Town Center Boulevard and Frontage Rd	A	8.8	A	9.2
Town Center Boulevard and MCP Westbound Ramps	A	4.9	A	5.3
Town Center Boulevard and MCP Eastbound Ramps	C	22.3	C	22.9
Town Center Boulevard and 5th Street	C	32.2	C	30.4
Park Center Boulevard and Marvin Road	C	34.0	C	28.0
Park Center Boulevard and MCP Westbound Ramps	B	14.3	B	18.1
Park Center Boulevard and MCP Eastbound Ramps	B	11.7	B	11.6
Park Center Boulevard and New Street	A	5.1	A	5.6
Warren Road and Ramona Expressway	C	22.4	B	19.9
Warren Road and MCP Westbound Ramps	A	5.4	A	6.7
Warren Road and MCP Eastbound Ramps	B	13.3	B	12.3
Warren Road and Record Road	A	9.7	B	10.8
Gilman Springs Road and SR 79 Southbound Ramps	B	19.1	B	17.5
Gilman Springs Road and SR 79 Northbound Ramps	B	17.8	C	25.2
Sanderson Ave and MCP	D	42.3	D	39.2
MCP and SR 79	C	27.6	C	33.5
Ramona Expressway and MCP	C	32.8	D	50.0
SR 79 Westbound Ramps and Sanderson Ave	C	24.3	C	26.4
SR 79 Eastbound Ramps and Sanderson Ave	A	9.5	B	12.0
Sanderson Ave and Cottonwood Avenue	D	48.6	D	41.9

Notes:

">80" – Exceeds 80 seconds

Table 7-13
Horizon Year (2040)
Freeway and HOV Lane Capacity Analysis (1)
Interstate 15 - Alternative 9 Modified

Northbound		Peak Hour Traffic (veh/hr)				Number of Lanes		Freeway Mainline and HOV Level of Service (2)				
		AM		PM				Freeway Capacity (3)	AM Peak Hour		PM Peak Hour	
Location	Facility	Freeway	HOV	Freeway	HOV	Freeway	HOV		LOS (4)	Density (5)	LOS (4)	Density (5)
I - 15 Mainline												
South of Temescal Canyon Rd	Freeway	7533		7617		4		8690	D	33.4	D	34.0
South of Temescal Canyon Rd	HOV		2904		2693		2		C	25.0	C	23.2
Temescal Canyon Rd On Ramp to Weirick Rd Off Ramp	Freeway	7912		7802		4		8690	E	36.4	E	35.5
Temescal Canyon Rd On Ramp to Weirick Rd Off Ramp	HOV		2904		2693		2		C	25.0	C	23.2
Weirick Rd On Ramp to Cajalco Rd Off Ramp	Freeway	8688		8369		4		8690	E	44.9	E	41.0
Weirick Rd On Ramp to Cajalco Rd Off Ramp	HOV		2904		2693		2		C	25.0	C	23.2
Cajalco Rd On Ramp to El Cerrito Rd Off Ramp	Freeway	9571		8812		4		8690	F	49.6	F	45.6
Cajalco Rd On Ramp to El Cerrito Rd Off Ramp	HOV		2904		2693		2		C	25.0	C	23.2
El Cerrito Rd On Ramp to Ontario Ave Off Ramp	Freeway	9193		7858		4		8690	F	47.6	E	35.9
El Cerrito Rd On Ramp to Ontario Ave Off Ramp	HOV		3600		3600		2		D	32.2	D	32.2
Ontario Ave On Ramp to Magnolia Ave Off Ramp	Freeway	9332		8060		4		8690	F	48.3	E	37.8
Ontario Ave On Ramp to Magnolia Ave Off Ramp	HOV		3600		3600		2		D	32.2	D	32.2
North of Magnolia Ave to SR-91	Freeway	9886		8465		4		8690	F	51.2	E	42.1
North of Magnolia Ave to SR-91	HOV		3600		3600		2		D	32.2	D	32.2

(1) Capacity Analysis shown for freeway mainline and HOV lanes. See separate page of Table 7-13 for ramps.

(2) One-lane HOV Lane density and level of service calculated using conditions for two freeway lanes and doubling the peak hour traffic.

(3) Freeway capacity is defined as the capacity at level of service E, expressed in vehicles per hour.

(4) LOS = Level of Service.

(5) Density is expressed in passenger cars/mile/lane. For facilities at level of service F, the density shown is the theoretical density that would occur if all demand could be accommodated.

Table 7-13 (cont.)
Horizon Year (2040)
Ramp Capacity Analysis (1)
Interstate 15 - Alternative 9 Modified

Northbound		Peak Hour Traffic (veh/hr)				Number of Lanes		Ramp Level of Service			
		AM		PM				AM Peak Hour		PM Peak Hour	
Location	Facility	Freeway	Ramp	Freeway	Ramp	Freeway	Ramp	LOS (2)	Density (3)	LOS (2)	Density (3)
I - 15 Mainline											
Temescal Canyon Rd Off Ramp	Diverge	7533	360	7617	495	4	1	D	32.3	D	33.4
Temescal Canyon Rd On Ramp	Merge	7173	739	7122	680	4	1	C	25.1	C	24.9
Weirick Rd Off Ramp	Diverge	7912	324	7802	446	4	1	D	33.7	D	33.9
Weirick Rd On Ramp	Merge	7588	1100	7356	1013	4	1	C	25.8	C	25.4
Cajalco Rd Off Ramp	Diverge	8688	821	8369	1129	4	1	F	45.0	F	45.0
Cajalco Rd EB On Ramp	Merge	7867	616	7240	567	4	1	C	26.8	C	25.3
Cajalco Rd WB On Ramp	Merge	8483	1088	7807	1005	4	1	F	49.6	C	26.3
El Cerrito Rd Off Ramp	Diverge	9571	497	8812	683	4	1	F	49.6	F	45.6
El Cerrito Rd On Ramp	Merge	9074	815	8129	656	4	1	F	47.6	C	27.4
Ontario Ave Off Ramp	Diverge	9193	986	7858	907	4	1	F	47.6	E	36.5
Ontario Ave On Ramp	Merge	8207	1125	6951	1109	4	1	F	48.3	C	24.5
Magnolia Ave Off Ramp	Diverge	9332	1250	8060	1021	4	1	F	48.3	F	45.0
Magnolia Ave EB On Ramp	Merge	8082	1203	7039	951	4	1	F	51.2	C	24.7
Magnolia Ave WB On Ramp	Merge	9285	601	7990	475	4	1	F	51.2	C	27.3

(1) Capacity analysis shown for ramps only. See separate page of Table 7-9 for freeway mainline and HOV lanes.

(2) LOS = Level of Service.

(3) Density is expressed in passenger cars/mile/lane. For facilities at level of service F, the density shown is the theoretical density that would occur if all demand could be accommodated based on capacity of the adjacent freeway segment.

Table 7-13 (cont.)
Horizon Year (2040)
Freeway and HOV Lane Capacity Analysis (1)
Interstate 15 - Alternative 9 Modified

Southbound		Peak Hour Traffic (veh/hr)				Number of Lanes		Freeway Mainline and HOV Level of Service (2)				
		AM		PM				Freeway Capacity (3)	AM Peak Hour		PM Peak Hour	
Location	Facility	Freeway	HOV	Freeway	HOV	Freeway	HOV		LOS (4)	Density (5)	LOS (4)	Density (5)
I - 15 Mainline												
SR-91 to Magnolia Ave	Freeway	9033		10892		4		8690	F	46.8	F	56.4
SR-91 to Magnolia Ave	HOV		2918		3600		2		C	25.2	D	32.2
Magnolia Ave On Ramp to Ontario Ave Off Ramp	Freeway	7750		10514		4		8690	E	35.1	F	54.4
Magnolia Ave On Ramp to Ontario Ave Off Ramp	HOV		2918		3600		2		C	25.2	D	32.2
Ontario Ave On Ramp to El Cerrito Rd Off Ramp	Freeway	7809		11014		4		8690	E	35.5	F	57.0
Ontario Ave On Ramp to El Cerrito Rd Off Ramp	HOV		2918		3600		2		C	25.2	D	32.2
El Cerrito Rd On Ramp to Cajalco Rd Off Ramp	Freeway	7833		10771		4		8690	E	35.7	F	55.8
El Cerrito Rd On Ramp to Cajalco Rd Off Ramp	HOV		2376		3267		2		C	20.5	D	28.4
Cajalco Rd On Ramp to Weirick Rd Off Ramp	Freeway	7440		9774		4		8690	D	32.7	F	50.6
Cajalco Rd On Ramp to Weirick Rd Off Ramp	HOV		2376		3267		2		C	20.5	D	28.4
Weirick Rd On Ramp to Temescal Canyon Rd Off Ramp	Freeway	6936		8901		4		8690	D	29.5	F	46.1
Weirick Rd On Ramp to Temescal Canyon Rd Off Ramp	HOV		2376		3267		2		C	20.5	D	28.4
South of Temescal Canyon Rd	Freeway	6771		8474		4		8690	D	28.6	E	42.2
South of Temescal Canyon Rd	HOV		2376		3267		2		C	20.5	D	28.4

(1) Capacity Analysis shown for freeway mainline and HOV lanes. See separate page of Table 7-13 for ramps.

(2) One-lane HOV Lane density and level of service calculated using conditions for two freeway lanes and doubling the peak hour traffic.

(3) Freeway capacity is defined as the capacity at level of service E, expressed in vehicles per hour.

(4) LOS = Level of Service.

(5) Density is expressed in passenger cars/mile/lane. For facilities at level of service F, the density shown is the theoretical density that would occur if all demand could be accommodated.

Table 7-13 (cont.)
Horizon Year (2040)
Ramp Capacity Analysis (1)
Interstate 15 - Alternative 9 Modified

Southbound		Peak Hour Traffic (veh/hr)				Number of Lanes		Ramp Level of Service			
		AM		PM				AM Peak Hour		PM Peak Hour	
Location	Facility	Freeway	Ramp	Freeway	Ramp	Freeway	Ramp	LOS (2)	Density (3)	LOS (2)	Density (3)
I - 15 Mainline											
Magnolia Ave Off Ramp	Diverge	9033	2190	10892	1625	4	1	F	46.8	F	56.4
Magnolia Ave On Ramp	Merge	6843	907	9267	1247	4	1	C	24.3	F	54.4
Ontario Ave Off Ramp	Diverge	7750	1289	10514	942	4	1	F	45.0	F	54.4
Ontario Ave On Ramp	Merge	6461	806	9572	1109	4	1	C	23.4	F	57.0
El Cerrito Rd Off Ramp	Diverge	7809	583	11014	802	4	1	D	34.6	F	57.0
El Cerrito Rd On Ramp	Merge	7226	607	10212	559	4	1	C	25.2	F	55.8
Cajalco Rd Off Ramp	Diverge	7833	1396	10771	1920	4	1	F	45.0	F	55.8
Cajalco Rd On Ramp	Merge	6437	1003	8851	923	4	1	C	23.5	F	50.6
Weirick Rd Off Ramp	Diverge	7440	900	9774	1238	4	1	D	34.8	F	50.6
Weirick Rd On Ramp	Merge	6540	396	8536	365	4	1	C	23.4	F	46.1
Temescal Canyon Rd Off Ramp	Diverge	6936	605	8901	832	4	1	D	31.2	F	46.1
Temescal Canyon Rd On Ramp	Merge	6331	440	8069	405	4	1	C	22.9	C	27.6

(1) Capacity analysis shown for ramps only. See separate page of Table 7-9 for freeway mainline and HOV lanes.

(2) LOS = Level of Service.

(3) Density is expressed in passenger cars/mile/lane. For facilities at level of service F, the density shown is the theoretical density that would occur if all demand could be accommodated based on capacity of the adjacent freeway segment.

Table 7-14
Horizon Year (2040)
Freeway and HOV Lane Capacity Analysis (1)
Interstate 215 - Alternative 9

Northbound		Peak Hour Traffic (veh/hr)				Number of Lanes		Freeway Mainline and HOV Level of Service (2)				
		AM		PM				Freeway Capacity (3)	AM Peak Hour		PM Peak Hour	
		Freeway	HOV	Freeway	HOV				LOS (4)	Density (5)	LOS (4)	Density (5)
Location	Facility											
I - 215 Mainline												
Nuevo Rd On Ramp to Mid County Parkway EB Off Ramp	Freeway	5286		5026		4		8690	C	21.8	C	20.7
Nuevo Rd On Ramp to Mid County Parkway EB Off Ramp	HOV		1800		1800		1		D	32.2	D	32.2
Mid County Parkway EB Off Ramp to Placentia Ave Off Ramp	Freeway	5056		4709		3		6470	D	29.0	D	26.6
Mid County Parkway EB Off Ramp to Placentia Ave Off Ramp	HOV		1800		1800		1		D	32.2	D	32.2
Placentia On Ramp to Mid County Parkway WB On Ramp	Freeway	5337		4769		3		6470	D	31.1	D	27.0
Placentia On Ramp to Mid County Parkway WB On Ramp	HOV		1800		1800		1		D	32.2	D	32.2
Mid County Parkway WB On Ramp to Cajalco/Ramona Expwy Off Ramp	Freeway	8408		7596		5		10930	D	27.8	C	24.6
Mid County Parkway WB On Ramp to Cajalco/Ramona Expwy Off Ramp	HOV		1800		1800		1		D	32.2	D	32.2
Cajalco/Ramona Expwy On Ramp to Harley Knox Blvd Off Ramp	Freeway	8427		7456		4		8690	E	41.7	D	32.8
Cajalco/Ramona Expwy On Ramp to Harley Knox Blvd Off Ramp	HOV		1800		1800		1		D	32.2	D	32.2
Harley Knox Blvd On Ramp to Van Buren Blvd Off Ramp	Freeway	8497		7809		4		8690	E	42.5	E	35.5
Van Buren Blvd Off Ramp	HOV		1800		1800		1		D	32.2	D	32.2
Harley Knox On Ramp to Van Buren Blvd On Ramp to Cactus Ave Off Ramp	Freeway	7906		7134		3		6470	F	55.0	F	49.6
Van Buren Blvd On Ramp to Cactus Ave Off Ramp	HOV		1800		1800		1		D	32.2	D	32.2
Cactus Ave On Ramp to Alessandro Blvd Off Ramp	Freeway	7722		6964		3		6470	F	53.7	F	48.4
Cactus Ave On Ramp to Alessandro Blvd Off Ramp	HOV		1800		1800		1		D	32.2	D	32.2
North of Alessandro Blvd	Freeway	7370		6640		3		6470	F	51.3	F	46.2
North of Alessandro Blvd	HOV		1800		1800		1		D	32.2	D	32.2

(1) Capacity Analysis shown for freeway mainline and HOV lanes. See separate page of Table 7-14 for ramps.

(2) One-lane HOV Lane density and level of service calculated using conditions for two freeway lanes and doubling the peak hour traffic.

(3) Freeway capacity is defined as the capacity at level of service E, expressed in vehicles per hour.

(4) LOS = Level of Service.

(5) Density is expressed in passenger cars/mile/lane. For facilities at level of service F, the density shown is the theoretical density that would occur if all demand could be accommodated.

Table 7-14 (cont.)
Horizon Year (2040)
Ramp Capacity Analysis (1)
Interstate 215 - Alternative 9

Northbound		Peak Hour Traffic (veh/hr)				Number of Lanes		Ramp Level of Service			
		AM		PM				AM Peak Hour		PM Peak Hour	
Location	Facility	Freeway	Ramp	Freeway	Ramp	Freeway	Ramp	LOS (2)	Density (3)	LOS (2)	Density (3)
I - 215 Mainline											
D Street On Ramp to Nuevo Rd Off Ramp	Weave (4)	6820		6793		4		E	35.3	D	33.8
Nuevo Rd Off Ramp	Diverge (5)	6820	518	6793	413	4	2	B	10.9	B	10.1
Nuevo Rd On Ramp	Merge (6)	6302	784	6380	446	3	1	C	21.8	C	20.7
Mid County Parkway EB Off Ramp	Diverge	5286	230	5026	317	3	1	D	30.5	D	29.4
Placentia Ave Off Ramp	Diverge	5056	439	4709	604	3	1	D	29.8	D	28.5
Placentia Ave On Ramp	Merge	4617	720	4105	664	3	1	D	31.2	D	28.2
Mid County Parkway WB On Ramp	Merge (6)	5337	3071	4769	2827	3	2	D	27.8	C	24.6
Cajalco/Ramona Expwy Off Ramp	Diverge	8408	871	7596	1198	5	2	B	13.1	B	13.8
Cajalco/Ramona Expwy On Ramp	Merge	7537	890	6398	1058	4	1	C	25.8	C	23.4
Harley Knox Blvd Off Ramp	Diverge	8427	558	7456	518	4	1	E	37.0	D	32.9
Harley Knox Blvd On Ramp	Merge	7869	628	6938	871	4	1	C	26.8	C	24.5
Van Buren Blvd Off Ramp	Diverge	8497	1286	7809	1315	4	2	C	20.3	B	18.8
Van Buren Blvd EB On Ramp	Merge	7211	572	6494	551	3	1	F	54.1	F	49.0
Van Buren Blvd WB On Ramp	Merge	7783	123	7045	89	3	1	F	55.0	F	49.6
Cactus Ave Off Ramp	Diverge	7906	746	7134	942	3	1	F	55.0	F	49.6
Cactus Ave EB On Ramp	Merge	7160	216	6192	297	3	1	F	53.7	F	48.4
Cactus Ave WB On Ramp	Merge	7376	346	6489	475	3	1	F	53.7	F	48.4
Alessandro Blvd Off Ramp	Diverge	7722	1021	6964	940	3	1	F	53.7	F	48.4
Alessandro Blvd On Ramp	Merge	6701	669	6024	616	3	1	F	51.3	F	46.2

(1) Capacity analysis shown for ramps only. See separate page of Table 7-14 for freeway mainline and HOV lanes.

(2) LOS = Level of Service.

(3) Density is expressed in passenger cars/mile/lane.

(4) For weaving volumes, see Figure 7-48c. The ramp to ramp movement was assumed to be zero. Weaving length is 2,000 feet per the I-215 widening project.

(5) Ramp capacity analysis shown for information only, since this is technically part of a weaving section.

(6) Level of service and density of downstream freeway assumed since lanes are added to freeway at this location.

Table 7-14 (cont.)
Horizon Year (2040)
Freeway and HOV Lane Capacity Analysis (1)
Interstate 215 - Alternative 9

Southbound		Peak Hour Traffic (veh/hr)				Freeway Mainline and HOV Level of Service (2)							
		AM		PM		Number of Lanes		Freeway Capacity (3)	AM Peak Hour		PM Peak Hour		
		Freeway	HOV	Freeway	HOV	Freeway	HOV		LOS (4)	Density (5)	LOS (4)	Density (5)	
Location	Facility												
I - 215 Mainline													
North of Alessandro Blvd	Freeway	5702		8516		3		6470	D	34.5	F	59.2	
North of Alessandro Blvd	HOV		1800		1800		1	6470	D	32.2	D	32.2	
Alessandro Blvd On Ramp to Cactus Ave Off Ramp	Freeway	5990		8912		3		6470	E	37.7	F	62.0	
Alessandro Blvd On Ramp to Cactus Ave Off Ramp	HOV		1800		1800		1	6470	D	32.2	D	32.2	
Cactus Ave On Ramp to Van Buren Blvd Off Ramp	Freeway	6142		9120		3		6470	E	39.7	F	63.4	
Cactus Ave On Ramp to Van Buren Blvd Off Ramp	HOV		1800		1800		1	6470	D	32.2	D	32.2	
Van Buren Blvd On Ramp to Harley Knox Blvd Off Ramp	Freeway	6738		9783		4		8690	D	28.4	F	50.7	
Van Buren Blvd On Ramp to Harley Knox Blvd Off Ramp	HOV		1800		1800		1	6470	D	32.2	D	32.2	
Harley Knox Blvd On Ramp to Cajalco/Ramona Expwy Off Ramp	Freeway	6428		9704		4		8690	D	26.8	F	50.3	
Harley Knox Blvd On Ramp to Cajalco/Ramona Expwy Off Ramp	HOV		1800		1800		1	6470	D	32.2	D	32.2	
Cajalco/Ramona Expwy On Ramp to Mid County Parkway EB Off Ramp	Freeway	6552		9684		5		10930	C	21.1	D	34.5	
Cajalco/Ramona Expwy On Ramp to Mid County Parkway EB Off Ramp	HOV		1800		1800		1	6470	D	32.2	D	32.2	
Mid County Parkway EB Off Ramp to Placentia Off Ramp	Freeway	4039		6229		4		8690	B	16.6	C	25.8	
Mid County Parkway EB Off Ramp to Placentia Off Ramp	HOV		1800		1800		1	6470	D	32.2	D	32.2	
Placentia Off Ramp to Placentia On Ramp	Freeway	3446		5418		3 (6)		6470	C	19.3	D	31.8	
Placentia Off Ramp to Placentia On Ramp	HOV		1800		1800		1	6470	D	32.2	D	32.2	
Placentia Ave On Ramp to Mid County Parkway WB On Ramp	Freeway	3983		5912		3		6470	C	22.4	E	36.7	
Placentia Ave On Ramp to Mid County Parkway WB On Ramp	HOV		1800		1800		1	6470	D	32.2	D	32.2	
Mid County Parkway WB On Ramp to Nuevo Rd Off Ramp	Freeway	4265		6171		4		8690	B	17.5	C	25.6	
Mid County Parkway WB On Ramp to Nuevo Rd Off Ramp	HOV		1800		1800		1	6470	D	32.2	D	32.2	

(1) Capacity Analysis shown for freeway mainline and HOV lanes. See separate page of Table 7-14 for ramps.

(2) One-lane HOV Lane density and level of service calculated using conditions for two freeway lanes and doubling the peak hour traffic.

(3) Freeway capacity is defined as the capacity at level of service E, expressed in vehicles per hour.

(4) LOS = Level of Service.

(5) Density is expressed in passenger cars/mile/lane. For facilities at level of service F, the density shown is the theoretical density that would occur if all demand could be accommodated.

Table 7-14 (cont.)
Horizon Year (2040)
Ramp Capacity Analysis (1)
Interstate 215 - Alternative 9

Southbound		Peak Hour Traffic (veh/hr)				Number of Lanes		Ramp Level of Service			
		AM		PM				AM Peak Hour		PM Peak Hour	
Location	Facility	Freeway	Ramp	Freeway	Ramp	Freeway	Ramp	LOS (2)	Density (3)	LOS (2)	Density (3)
I - 215 Mainline											
Alessandro Blvd Off Ramp	Diverge	5702	554	8516	752	3	1	D	32.7	F	59.2
Alessandro Blvd WB On Ramp	Merge	5148	254	7764	346	3	1	D	30.2	F	56.4
Alessandro Blvd EB On Ramp	Merge	5402	588	8110	802	3	1	D	34.1	F	62.0
Cactus Ave WB Off Ramp	Diverge	5990	422	8912	389	3	1	D	33.7	F	62.0
Cactus Ave EB Off Ramp	Diverge	5568	264	8523	243	3	1	D	31.7	F	59.3
Cactus Ave On Ramp	Merge	5304	838	8280	840	3	1	E	35.6	F	63.4
Van Buren Blvd Off Ramp	Diverge	6142	569	9120	782	3	1	D	34.5	F	63.4
Van Buren Blvd On Ramp	Merge (4)	5573	1165	8338	1445	3	1	D	28.4	F	50.7
Harley Knox Blvd Off Ramp	Diverge	6738	766	9783	713	4	1	D	31.2	F	50.7
Harley Knox Blvd On Ramp	Merge	5972	456	9070	634	4	1	C	21.9	F	50.3
Cajalco/Ramona Expwy Off Ramp	Diverge	6428	941	9704	1000	4	1	D	30.9	F	50.3
Cajalco/Ramona Expwy On Ramp	Merge (4)	5487	1065	8704	980	4	2	C	21.1	D	34.5
Mid County Parkway EB Off Ramp	Diverge (5)	6552	2513	9684	3455	5	2	C	21.1	D	34.5
Placentia Ave Off Ramp	Diverge	4039	593	6229	811	4	1	B	19.3	D	29.4
Placentia Ave On Ramp	Merge	3446	537	5418	494	3	1	C	23.9	D	33.4
Mid County Parkway WB On Ramp	Merge (4)	3983	282	5912	259	3	1	B	17.5	C	25.6
Nuevo Rd Off Ramp	Diverge (6)	6065	396	7971	545	3	1	B	17.5	C	25.6
Nuevo Rd On Ramp	Merge (7)	5669	634	7426	583	3	1	E	35.8	F	55.7
Nuevo Rd On Ramp to D Street Off Ramp	Weave (8)	6303		8009		4		D	32.2	E	42.8

(1) Capacity analysis shown for ramps only. See separate page of Table 7-14 for freeway mainline and HOV lanes.

(2) LOS = Level of Service.

(3) Density is expressed in passenger cars/mile/lane.

(4) Level of service and density of downstream freeway since lanes are added to the freeway at this point.

(5) Major diverge area. Level of service and density assumed to be the same as upstream freeway segment.

(6) Off ramp removes one lane at this location. LOS and density of upstream freeway assumed.

(7) Ramp capacity analysis shown for information only, since this is technically part of a weaving section.

(8) For weaving volumes, see Figure 7-48c. The ramp to ramp movement was assumed to be zero. Weaving length is 2,000 feet per the I-215 widening project

Table 7-15
Horizon Year (2040)
Freeway Capacity Analysis (1)
Mid County Parkway - Alternative 9 Modified

Eastbound		Peak Hour Traffic (veh/hr)			Freeway Mainline Level of Service				
					Freeway Capacity (2)	AM Peak Hour		PM Peak Hour	
Location	Facility	AM	PM	Number of Lanes		LOS (3)	Density (4)	LOS (3)	Density (4)
Mid County Parkway									
I-215 to Redlands Ave Off Ramp	Freeway	2743	3772	3	6470	B	15.4	C	21.2
Redlands Ave On Ramp to Evans Rd Off Ramp	Freeway	3008	4049	3	6470	B	16.9	C	22.7
Evans Rd On Ramp to Ramona Expwy Off Ramp	Freeway	2866	3940	3	6470	B	16.1	C	22.1
Ramona Expwy On Ramp to Bernasconi Rd Off Ramp	Freeway	3377	4643	3	6470	C	19.0	D	26.2
Bernasconi Rd On Ramp to Reservoir Ave Off Ramp	Freeway	3424	4562	3	6470	C	19.2	C	25.7
Reservoir Ave On Ramp to Town Center Blvd Off Ramp	Freeway	3197	4396	3	6470	B	18.0	C	24.7
Town Center Blvd On Ramp to Park Center Blvd Off Ramp	Freeway	2425	3413	3	6470	B	13.6	C	19.2
Park Center Blvd On Ramp to Warren Rd Off Ramp	Freeway	2684	3517	3	6470	B	15.1	C	19.8
Warren Rd On Ramp to SR-79	Freeway	1955	2753	3	6470	A	11.0	B	15.5

(1) Capacity Analysis shown for freeway mainline and HOV lanes. See separate page of Table 7-15 for ramps.

(2) Freeway capacity is defined as the capacity at level of service E, expressed in vehicles per hour.

(3) LOS = Level of Service.

(4) Density is expressed in passenger cars/mile/lane. For facilities at level of service F, the density shown is the theoretical density that would occur if all demand could be accommodated.

Table 7-15 (cont.)
Horizon Year (2040)
Ramp Capacity Analysis (1)
Mid County Parkway - Alternative 9 Modified

Eastbound		Peak Hour Traffic (veh/hr)				Number of Lanes		Ramp Level of Service			
		AM		PM				AM Peak Hour		PM Peak Hour	
Location	Facility	Freeway	Ramp	Freeway	Ramp	Freeway	Ramp	LOS (2)	Density (3)	LOS (2)	Density (3)
Mid County Parkway											
MCP Northbound/Southbound On Ramps	Merge	2513	230	3455	317	2	1	B	15.4	C	21.2
Redlands Ave Off Ramp	Diverge	2743	392	3772	545	3	1	B	18.0	C	23.8
Redlands Ave On Ramp	Merge	2351	657	3227	822	3	1	B	19.4	C	25.1
Evans Rd Off Ramp	Diverge	3008	483	4049	563	3	1	B	19.7	C	25.3
Evans Rd On Ramp	Merge	2526	340	3486	454	3	1	B	17.7	C	23.4
Ramona Expwy Off Ramp	Diverge	2866	230	3940	317	3	1	B	18.4	C	24.3
Ramona Expwy On Ramp	Merge	2636	741	3623	1020	3	1	C	21.5	D	28.6
Bernasconi Rd Off Ramp	Diverge	3377	274	4643	376	3	1	C	21.3	C	27.8
Bernasconi Rd On Ramp	Merge	3103	321	4267	295	3	1	C	20.5	C	26.1
Reservoir Ave Off Ramp	Diverge	3424	517	4562	533	3	1	C	22.0	C	27.7
Reservoir Ave On Ramp	Merge	2907	290	4029	367	3	1	B	19.2	C	25.5
Town Center Blvd Off Ramp	Diverge	3197	974	4396	1169	3	1	C	21.8	D	28.2
Town Center Blvd On Ramp	Merge	2223	202	3227	186	3	1	B	15.1	B	20.0
Park Center Blvd Off Ramp	Diverge	2425	295	3413	406	3	1	B	16.0	C	21.7
Park Center Blvd On Ramp	Merge	2130	554	3007	510	3	1	B	17.4	C	21.5
Warren Rd Off Ramp	Diverge	2684	975	3517	1191	3	1	B	19.1	C	24.0
Warren Rd On Ramp	Merge	1709	247	2326	427	3	1	B	12.9	B	17.4

(1) Capacity analysis shown for ramps only. See separate page of Table 7-15 for freeway mainline and HOV lanes.

(2) LOS = Level of Service.

(3) Density is expressed in passenger cars/mile/lane.

Table 7-15 (cont.)
Horizon Year (2040)
Freeway Capacity Analysis (1)
Mid County Parkway - Alternative 9 Modified

Westbound		Peak Hour Traffic (veh/hr)			Freeway Mainline Level of Service					
					Capacity (2)	AM Peak Hour		PM Peak Hour		
Location	Facility	AM	PM	Number of Lanes		LOS (3)	Density (4)	LOS (3)	Density (4)	
Mid County Parkway										
SR-79 to Warren Rd Off Ramp		Freeway	2356	2250	3	6470	B	13.2	B	12.6
Warren Rd On Ramp to Park Center Blvd Off Ramp		Freeway	3017	3085	3	6470	B	16.9	B	17.3
Park Center Blvd On Ramp to Town Center Blvd Off Ramp		Freeway	2928	2793	3	6470	B	16.4	B	15.7
Town Center Blvd On Ramp to Reservoir Ave Off Ramp		Freeway	3906	3596	3	6470	C	21.9	C	20.2
Reservoir Ave On Ramp to Bernasconi Rd Off Ramp		Freeway	4075	3855	3	6470	C	22.9	C	21.6
Bernasconi Rd On Ramp to Ramona Expwy Off Ramp		Freeway	4126	3799	3	6470	C	23.2	C	21.3
Ramona Expwy On Ramp to Evans Rd Off Ramp		Freeway	3501	3224	3	6470	C	19.7	C	18.1
Evans Rd On Ramp to Redlands Ave Off Ramp		Freeway	3693	3388	3	6470	C	20.7	C	19.0
Redlands Ave On Ramp to I-215		Freeway	3353	3086	3	6470	C	18.8	B	17.3

(1) Capacity Analysis shown for freeway mainline and HOV lanes. See separate page of Table 7-15 for ramps.

(2) Freeway capacity is defined as the capacity at level of service E, expressed in vehicles per hour.

(3) LOS = Level of Service.

(4) Density is expressed in passenger cars/mile/lane. For facilities at level of service F, the density shown is the theoretical density that would occur if all demand could be accommodated.

Table 7-15 (cont.)
Horizon Year (2040)
Ramp Capacity Analysis (1)
Mid County Parkway - Alternative 9 Modified

Westbound		Peak Hour Traffic (veh/hr)				Number of Lanes		Ramp Level of Service			
		AM		PM				AM Peak Hour		PM Peak Hour	
Location	Facility	Freeway	Ramp	Freeway	Ramp	Freeway	Ramp	LOS (2)	Density (3)	LOS (2)	Density (3)
Mid County Parkway											
Warren Rd Off Ramp	Diverge	2356	202	2250	277	3	1	B	15.4	B	15.0
Warren Rd On Ramp	Merge	2154	861	1973	1112	3	1	B	18.5	B	19.1
Park Center Blvd Off Ramp	Diverge	3017	454	3085	624	3	1	B	19.7	C	20.4
Park Center Blvd On Ramp	Merge	2563	362	2461	332	3	1	B	17.4	B	17.3
Town Center Blvd Off Ramp	Diverge	2925	166	2793	228	3	1	B	18.6	B	18.0
Town Center Blvd On Ramp	Merge	2759	1147	2565	1031	3	1	C	25.3	C	23.4
Reservoir Ave Off Ramp	Diverge	3906	238	3596	327	3	1	C	24.0	C	22.5
Reservoir Ave On Ramp	Merge	3668	407	3269	586	3	1	C	24.0	C	23.4
Bernasconi Rd Off Ramp	Diverge	4075	283	3855	364	3	1	C	24.9	C	23.9
Bernasconi Rd On Ramp	Merge	3792	334	3491	308	3	1	C	24.0	C	22.3
Ramona Expwy Off Ramp	Diverge	4126	907	3799	834	3	1	C	26.3	C	24.6
Ramona Expwy On Ramp	Merge	3219	282	2965	259	3	1	C	20.1	B	19.3
Evans Rd Off Ramp	Diverge	3501	403	3224	554	3	1	C	22.2	C	21.0
Evans Rd On Ramp	Merge	3098	595	2670	718	3	1	C	21.6	C	21.4
Redlands Ave Off Ramp	Diverge	3693	724	3388	747	3	1	C	23.8	C	22.3
Redlands Ave On Ramp	Merge	2969	384	2641	445	3	1	C	20.3	B	19.1
MCP Northbound/Southbound Off Ramps	Diverge	282	3071	259	2827	1	2	C	18.8	B	17.3

(1) Capacity analysis shown for ramps only. See separate page of Table 7-15 for freeway mainline and HOV lanes.

(2) LOS = Level of Service.

(3) Density is expressed in passenger cars/mile/lane.

Table 7-16
Horizon Year (2040)
Intersection Capacity Analysis - Alternative 9 Modified
I-15 Area

Intersection	AM Peak Hour		PM Peak Hour	
	LOS	Average Delay (sec)	LOS	Average Delay (sec)
Magnolia Avenue and El Sobrante Road	F	>80.0	F	>80.0
Magnolia Avenue and I-15 Southbound Ramps	F	>80.0	F	>80.0
Magnolia Avenue and I-15 Northbound Ramps	B	18.0	C	23.9
Magnolia Avenue and El Camino Avenue	C	20.1	E	70.8
Ontario Avenue and California Avenue	D	51.0	F	>80.0
Ontario Avenue and I-15 Southbound Ramps	C	23.4	B	15.2
Ontario Avenue and I-15 Northbound Ramps	C	29.3	C	33.3
Ontario Avenue and State Street	B	13.0	B	13.2
El Cerrito Road and Bedford Canyon Road	C	26.7	C	28.0
El Cerrito Road and I-15 Southbound Ramps	B	17.5	C	22.7
El Cerrito Road and I-15 Northbound Ramps	D	35.6	C	20.8
El Cerrito Road and Temescal Canyon Road	C	31.4	C	30.7
Cajalco Road and Bedford Canyon Road	C	20.1	C	30.9
Cajalco Road and I-15 Southbound Ramps	C	24.2	C	24.0
Cajalco Road and I-15 Northbound Ramps	B	10.8	B	15.2
Cajalco Road and Temescal Canyon Road	E	61.4	F	>80.0
Weirick Road and Knabe Road	C	26.7	C	28.9
Weirick Road and I-15 Southbound Ramps	C	22.1	B	16.8
Weirick Road and I-15 Northbound Ramps	A	9.3	B	11.3
Weirick Road and Temescal Canyon Road	C	22.1	C	29.2
Temescal Canyon Road and Lawson Drive	C	20.4	B	18.8
Temescal Canyon Road and I-15 Southbound Ramps	B	15.5	D	38.8
Temescal Canyon Road and I-15 Northbound Ramps	C	22.5	C	24.9

Notes:

">80" – Exceeds 80 seconds

Table 7-16 (cont.)
 Horizon Year (2040)
 Intersection Capacity Analysis - Alternative 9 Modified
 Cajalco Road, I-15 to I-215

Intersection	AM Peak Hour		PM Peak Hour	
	LOS	Average Delay (sec)	LOS	Average Delay (sec)
Eagle Valley Road and Cajalco Road	C	20.3	B	16.6
Lake Mathews Road and Cajalco Road	B	11.7	B	17.7
El Sobrante Road and Calalco Road	B	19.2	B	16.5
Wood Road and Cajalco Road	C	22.7	C	23.8
Alexander Street and Cajalco Road	B	19.4	B	15.1
Clark Street and Cajalco Road	C	26.3	D	42.5

Notes:

">80" – Exceeds 80 seconds

Table 7-16 (cont.)
Horizon Year (2040)
Intersection Capacity Analysis - Alternative 9 Modified
I-215 Area

Intersection	AM Peak Hour		PM Peak Hour	
	LOS	Average Delay (sec)	LOS	Average Delay (sec)
Alessandro Blvd and Meridian Parkway	F	>80.0	F	>80.0
Alessandro Blvd and I-215 Southbound Ramps	F	>80.0	F	>80.0
Alessandro Blvd and I-215 Northbound Ramps	F	>80.0	F	>80.0
Alessandro Blvd and Valley Springs Parkway	F	>80.0	F	>80.0
Cactus Avenue and Innovation Drive	C	30.8	D	35.8
Cactus Avenue and I-215 Southbound Ramps	B	17.4	B	19.9
Cactus Avenue and I-215 Northbound Ramps	C	28.2	D	52.5
Cactus Avenue and Ellsworth Street	D	40.1	D	36.0
Van Buren Boulevard and Meridian Parkway	C	28.9	E	77.6
Van Buren Boulevard and I-215 Southbound Ramps	B	12.4	B	14.0
Van Buren Boulevard and I-215 Northbound Ramps	C	25.3	C	24.7
Harley Knox Blvd and Harvill Avenue	C	21.3	C	24.5
Harley Knox Blvd and I-215 Southbound Ramps	B	17.0	C	20.9
Harley Knox Blvd and I-215 Northbound Ramps	B	19.6	B	16.3
Harley Knox Blvd and Western Way	B	10.1	B	10.9
Cajalco Road and Harvill Avenue	D	46.1	D	41.2
Cajalco Road and I-215 Southbound Ramps	B	18.7	B	20.0
Cajalco Road and I-215 Northbound Ramps	C	20.3	C	23.6
Ramona Expressway and Patterson Avenue	B	18.0	C	26.9
Ramona Expressway and Webster Avenue	D	40.1	C	34.9
Placentia Avenue and Harvill Avenue	D	35.3	D	41.5
Placentia Avenue and I-215 Southbound Ramps	B	15.5	B	17.2
Placentia Avenue and I-215 Northbound Ramps	B	15.7	B	17.4
Placentia Avenue and East Frontage Road	A	8.6	A	6.6
Nuevo Road and A Street	B	19.5	C	21.3
Nuevo Road and I-215 Southbound Ramps	C	20.3	C	20.6
Nuevo Road and I-215 Northbound Ramps	A	8.4	A	6.7
Nuevo Road and Old Nuevo Road	C	33.5	D	39.3

Notes:

">80" – Exceeds 80 seconds

Table 7-16 (cont.)
Horizon Year (2040)
Intersection Capacity Analysis - Alternative 9 Modified
Mid County Parkway, I-215 to SR 79

Intersection	AM Peak Hour		PM Peak Hour	
	LOS	Average Delay (sec)	LOS	Average Delay (sec)
Redlands Ave and Rider Street	C	30.7	C	33.2
Redlands Ave and MCP Westbound Ramps	C	21.5	C	25.7
Redlands Ave and MCP Eastbound Ramps	B	16.8	B	18.1
Redlands Ave and Placentia Avenue	C	27.2	C	29.7
Evans Road and Rider Street	C	27.4	C	24.6
Evans Road and MCP Westbound Ramps	A	7.9	A	9.7
Evans Road and MCP Eastbound Ramps	A	9.8	A	9.4
Evans Road and Orange Ave	C	34.8	D	42.4
Ramona Expressway and Rider Street	D	38.9	B	13.5
Ramona Expressway and MCP Westbound Ramps	B	13.1	A	8.2
Ramona Expressway and MCP Eastbound Ramps	B	12.6	B	17.4
Ramona Expressway and Orange Ave	C	29.1	D	37.4
Bernasconi Road and New St	B	12.6	B	12.9
Bernasconi Road and MCP Westbound Ramps	B	13.8	B	15.5
Bernasconi Road and MCP Eastbound Ramps	B	14.9	B	14.5
Bernasconi Road and Orange Avenue	C	33.6	D	35.5
Reservoir Avenue and Martin St	D	36.6	D	37.1
Reservoir Avenue and MCP Westbound Ramps	B	16.4	B	16.7
Reservoir Avenue and MCP Eastbound Ramps	B	10.7	B	11.2
Reservoir Avenue and 9th Street	B	16.0	B	16.8
Town Center Boulevard and Frontage Rd	B	12.0	B	13.2
Town Center Boulevard and MCP Westbound Ramps	A	5.9	A	5.4
Town Center Boulevard and MCP Eastbound Ramps	C	21.3	C	21.0
Town Center Boulevard and 5th Street	C	33.3	C	32.6
Park Center Boulevard and Marvin Road	C	33.7	C	32.3
Park Center Boulevard and MCP Westbound Ramps	B	13.5	B	16.1
Park Center Boulevard and MCP Eastbound Ramps	B	11.4	B	11.6
Park Center Boulevard and New Street	A	7.8	A	8.1
Warren Road and Ramona Expressway	C	24.3	C	21.8
Warren Road and MCP Westbound Ramps	A	5.4	A	6.3
Warren Road and MCP Eastbound Ramps	B	12.6	B	11.5
Warren Road and Record Road	B	10.1	B	11.0
Gilman Springs Road and SR 79 Southbound Ramps	B	19.0	B	17.4
Gilman Springs Road and SR 79 Northbound Ramps	B	17.8	C	25.1
Sanderson Ave and MCP	C	34.8	D	51.9
MCP and SR 79	C	25.9	C	33.9
Ramona Expressway and MCP	D	36.6	D	48.8
SR 79 Westbound Ramps and Sanderson Ave	C	24.3	C	26.4
SR 79 Eastbound Ramps and Sanderson Ave	A	9.5	B	12.0
Sanderson Ave and Cottonwood Avenue	D	48.6	D	41.9

Notes:

">80" – Exceeds 80 seconds

Table 7-17 (cont.)
 Horizon Year (2040)
 Intersection Capacity Analysis - San Jacinto North Design Variation

Intersection	AM Peak Hour		PM Peak Hour	
	LOS	Average Delay (sec)	LOS	Average Delay (sec)
Warren Road and Pico Road	C	29.6	C	31.9
Warren Road and MCP Westbound Ramps	A	6.3	A	7.5
Warren Road and MCP Eastbound Ramps	B	14.1	B	13.1
Warren Road and Ramona Expressway	C	30.4	C	25.0
Gilman Springs Road and SR 79 Southbound Ramps	B	19.0	B	17.4
Gilman Springs Road and SR 79 Northbound Ramps	B	17.8	C	25.1
Sanderson Ave and MCP	D	36.9	D	35.7
MCP and SR 79 Southbound Ramps	C	24.2	C	23.1
MCP and SR 79 Northbound Ramps	A	4.1	A	5.9

Notes:

">80" - Exceeds 80 seconds

8.0 TRAFFIC IMPACTS AND MITIGATION

This chapter provides analysis of traffic impacts and mitigation.

ANALYSIS OF IMPACTS – 2020 OPENING YEAR CONDITIONS

Most of the freeways, ramps, and intersections within the study area are expected to operate at acceptable levels of service in the opening year of 2020 for the Build alternative. Exceptions are noted below:

- ◆ The interchange of Interstate 15 (I-15) and Magnolia Avenue and the Magnolia Avenue/El Sobrante Road intersection are expected to experience traffic congestion in the opening year of 2020 for the No Build and the Build alternatives. However, traffic levels for the Build alternative are not significantly higher than traffic levels for the No Build alternative. Therefore, there are no adverse traffic conditions caused by the project at this location.
- ◆ Traffic forecasts are expected to exceed the mainline capacity of Interstate 215 (I-215) in the AM and PM peak hours in 2020 under No Build and Build conditions, causing level of service (LOS) E and F conditions for freeway segments, weaving segments, and ramp merge and diverge areas. Between Van Buren Boulevard and Nuevo Road, the project is expected to add traffic to I-215 north of the I-215/Mid County Parkway (MCP) interchange and reduce traffic south of the I-215/MCP interchange, as compared to the No Build condition. However, the MCP project includes the addition of one mainline lane in each direction of traffic along I-215 from Nuevo Road to Van Buren Boulevard. The additional mainline lanes provide more capacity than is lost through the addition of project traffic and traffic conditions in the Build condition along I-215 from Nuevo Road to Van Buren Boulevard are better than in the No Build condition.
- ◆ The intersections of Alessandro Boulevard with Meridian Parkway, the I-215 Southbound Ramps, and Valley Springs Parkway are expected to experience traffic congestion under No Build and Build conditions in 2020. However, traffic levels for the Build alternative are not significantly higher than traffic levels for the No Build alternative. Therefore, there are no adverse traffic conditions caused by the project at this location.

ANALYSIS OF IMPACTS – 2040 HORIZON YEAR CONDITIONS

Most of the freeways, ramps, and intersections within the study area are expected to operate at acceptable levels of service in the horizon year of 2040 for all of the Build alternatives and design variations. Exceptions are noted below:

- ◆ The interchange of I-15 and Magnolia Avenue and the Magnolia Avenue/El Sobrante Road intersection are expected to experience traffic congestion in the horizon year of 2040 for the No Build and all of the Build alternatives and design variations. Traffic levels for the Build alternatives are not significantly higher than traffic levels for the No Build. Therefore, there are no adverse traffic impacts caused by the project at this location.

- ◆ Traffic forecasts are expected to exceed the mainline capacity of I-215 in the AM and PM peak hours in 2040 under No Build and Build conditions, causing LOS E and F conditions for freeway segments, weaving segments and ramp merge and diverge areas. Between Van Buren Boulevard and Nuevo Road, the project is expected to add traffic to I-215 north of the I-215/MCP interchange and reduce traffic south of the I-215/Mid County Parkway interchange, as compared to the No Build condition. However, the Mid County Parkway project includes the addition of one mainline lane in each direction of traffic along I-215 from Nuevo Road to Van Buren Boulevard. The additional mainline lanes provide more capacity than is lost through the addition of project traffic and traffic conditions in the Build condition along I-215 from Nuevo Road to Van Buren Boulevard are better than in the No Build condition.
- ◆ The intersections of Alessandro Boulevard with Meridian Parkway, the I-215 Southbound Ramps, the I-215 Northbound Ramps, and Valley Springs Parkway are expected to experience traffic congestion under No Build and Build condition in 2040. However, traffic levels for the Build alternative are not significantly higher than traffic levels for the No Build alternative. Therefore, there are no adverse traffic conditions caused by the project at this location.
- ◆ The intersection of Van Buren Boulevard and Meridian Parkway is expected to experience traffic congestion (LOS E) in the No Build condition in 2040. For MCP Alternatives 4 Modified and 5 Modified (and all design variations associated with these alternatives), LOS D operating conditions are expected in the peak hours and this falls outside of the threshold for traffic congestion. For MCP Alternative 9 Modified (and all design variations associated with this alternative), there is not a significant change in LOS or delay with addition of the project.

MITIGATION

Based on the analysis described above, the project is not expected to have any significant traffic impacts and no mitigation measures are recommended.

9.0 PROJECT PHASING

The Mid County Parkway (MCP) project is proposed to be built in a single phase with an expected opening year of 2020. If sufficient funding is available, it is RCTC's intention that the entire project be built by 2020. Therefore, the 2040 traffic analysis covers the design life of the project.

It is also possible that the project will be built in multiple phases. This chapter provides analysis of an alternative future scenario assuming phased implementation of the project. The analysis of the phased implementation of the project was conducted assuming that the initial phase of the project is built in 2020, a subsequent phase is built by 2030, and the project is completed by 2040.

PROJECT PHASING METHODOLOGY

The proposed phasing plan if the project were to be built in phases is shown in Figures 9-1 through 9-7 and is summarized below:

- ◆ The initial phase of the project would be built by 2020 and would include a four-lane MCP from west of Reservoir Avenue to east of Warren Road, an interchange at Interstate 215 (I-215)/Placentia Avenue, and one additional lane in each direction on I-215 from Nuevo Road to Van Buren Boulevard. See Figure 9-1. This initial phase is common to Alternatives 4, 5, and 9, so any of these three alternatives could be implemented following completion of the initial phase.
- ◆ The second phase of the project would be built by 2030 and would include completion of the MCP as a four-lane freeway from State Route 79 (SR-79) to I-215. The interchange at I-215 would include only the southbound to eastbound and westbound to northbound ramps. At SR-79, the freeway-to-freeway ramps that are included in the ultimate project would not be provided in this phase, but access would be provided from the Mid County Parkway to SR-79 through a service interchange with signalized control for the MCP facility. This phase is shown separately for Alternatives 4, 5, and 9 in Figures 9-2 through 9-4.
- ◆ The final phase of the project would be built by 2040 and would include widening of the MCP to six lanes, addition of northbound to eastbound and westbound to southbound ramps at the I-215/MCP interchange, and provision of a freeway-to-freeway interchange (system interchange) at SR-79 and the MCP. This phase is shown separately for Alternatives 4, 5, and 9 in Figures 9-5 through 9-7.

Of the three phases described above, traffic analysis for the 2020 and 2040 phases have been described in detail in Chapters 6 and 7. The remainder of this chapter provides traffic analysis of 2030 conditions, assuming the phasing plan described above.

Traffic analysis for 2030 conditions was conducted using a different level of detail than the traffic analysis conducted for 2020 and 2040 traffic conditions. The methodology that was used is described as follows:

- ◆ The roadway network for 2030 was assumed to be similar to the roadway network for 2020 conditions, since relatively few major roadway improvements are expected to be built along key corridors in the study area between 2020 and 2030.
- ◆ Traffic forecasts for 2030 were determined for Average Daily Traffic (ADT) conditions only. Traffic forecasts were determined through a linear interpolation of 2020 and 2040 traffic forecasts.
- ◆ Capacity analysis for 2030 conditions was based on roadway segment ADT conditions. The roadway level of service (LOS) table from the Riverside County General Plan was used to determine roadway levels of service for 2030 conditions.

The remainder of this chapter provides traffic analysis for 2030 traffic conditions. The analysis is provided separately for the No Build condition and Alternatives 4, 5, and 9.

2030 NO BUILD TRAFFIC CONDITIONS

Traffic forecasts for 2030 No Build are shown in Figure 9-8. Capacity analysis is shown in Table 9-1.

2030 ALTERNATIVE 4 TRAFFIC CONDITIONS

Traffic forecasts for 2030 for Alternative 4 are shown in Figure 9-9. Capacity analysis is shown in Table 9-2.

2030 ALTERNATIVE 5 TRAFFIC CONDITIONS

Traffic forecasts for 2030 for Alternative 5 are shown in Figure 9-10. Capacity analysis is shown in Table 9-3.

2030 ALTERNATIVE 9 TRAFFIC CONDITIONS

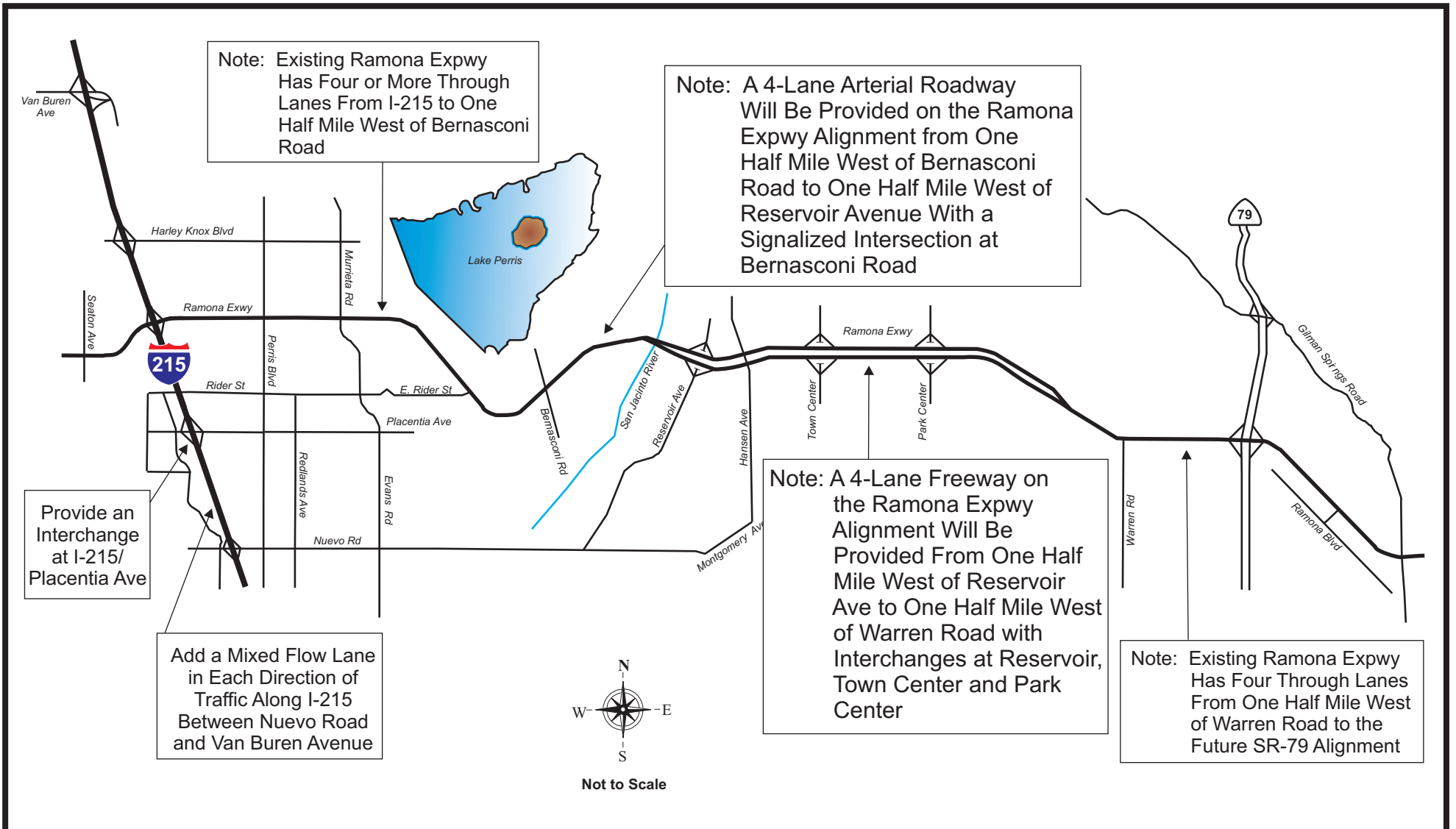

Traffic forecasts for 2030 for Alternative 9 are shown in Figure 9-11. Capacity analysis is shown in Table 9-4.



**Mid County Parkway - Opening Year (2020)
Proposed Improvements - Applicable to
Modified Alternatives 4, 5 & 9**

Figure 9-1

LEGEND

-  Existing or Proposed Arterial Roadway
-  Existing or Proposed Freeway



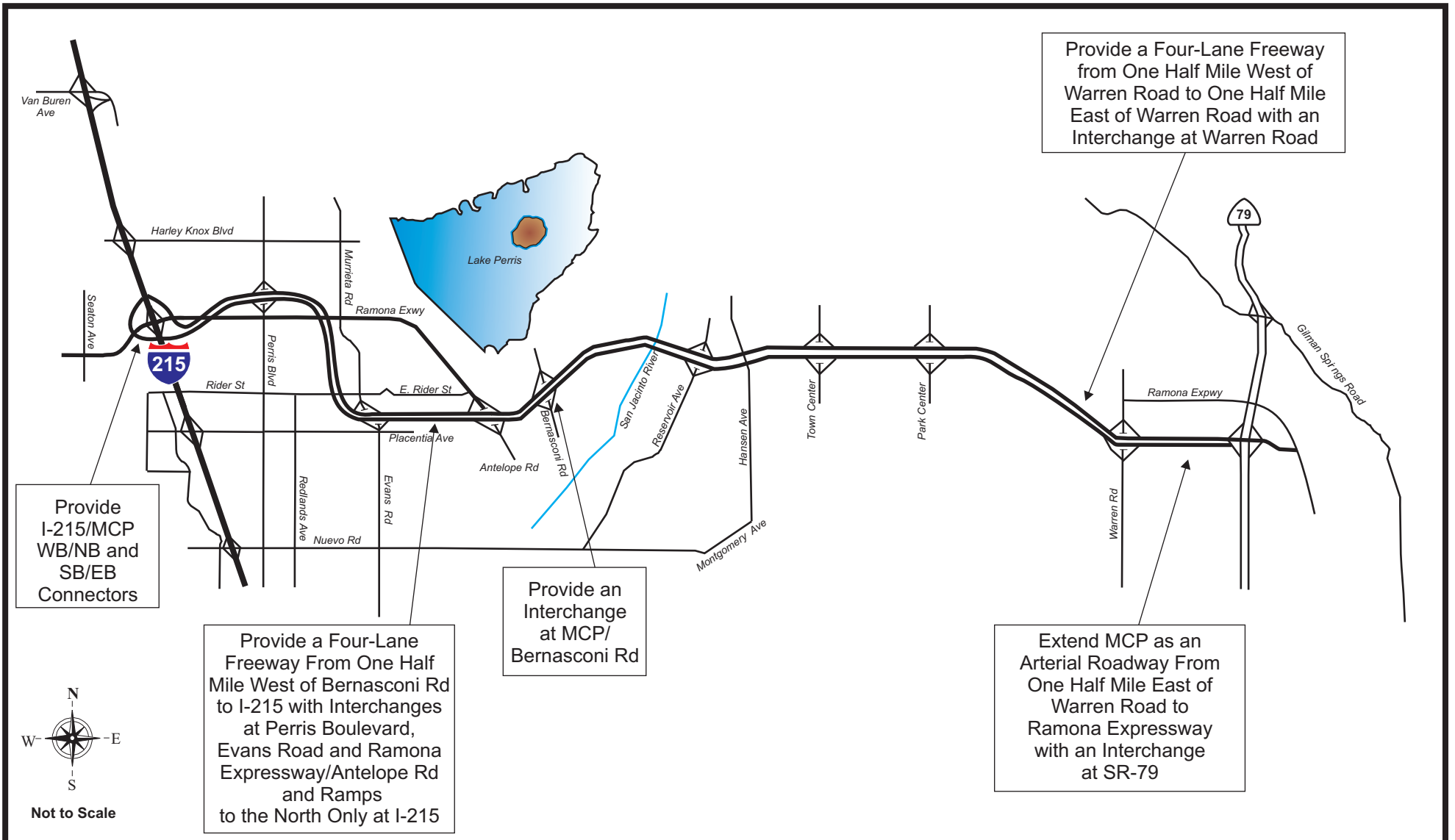



Mid County Parkway - Alternative 4 Modified Proposed Improvements: Future Year (2030)

Figure 9-2

LEGEND

-  Existing or Proposed Arterial Roadway
-  Existing or Proposed Freeway



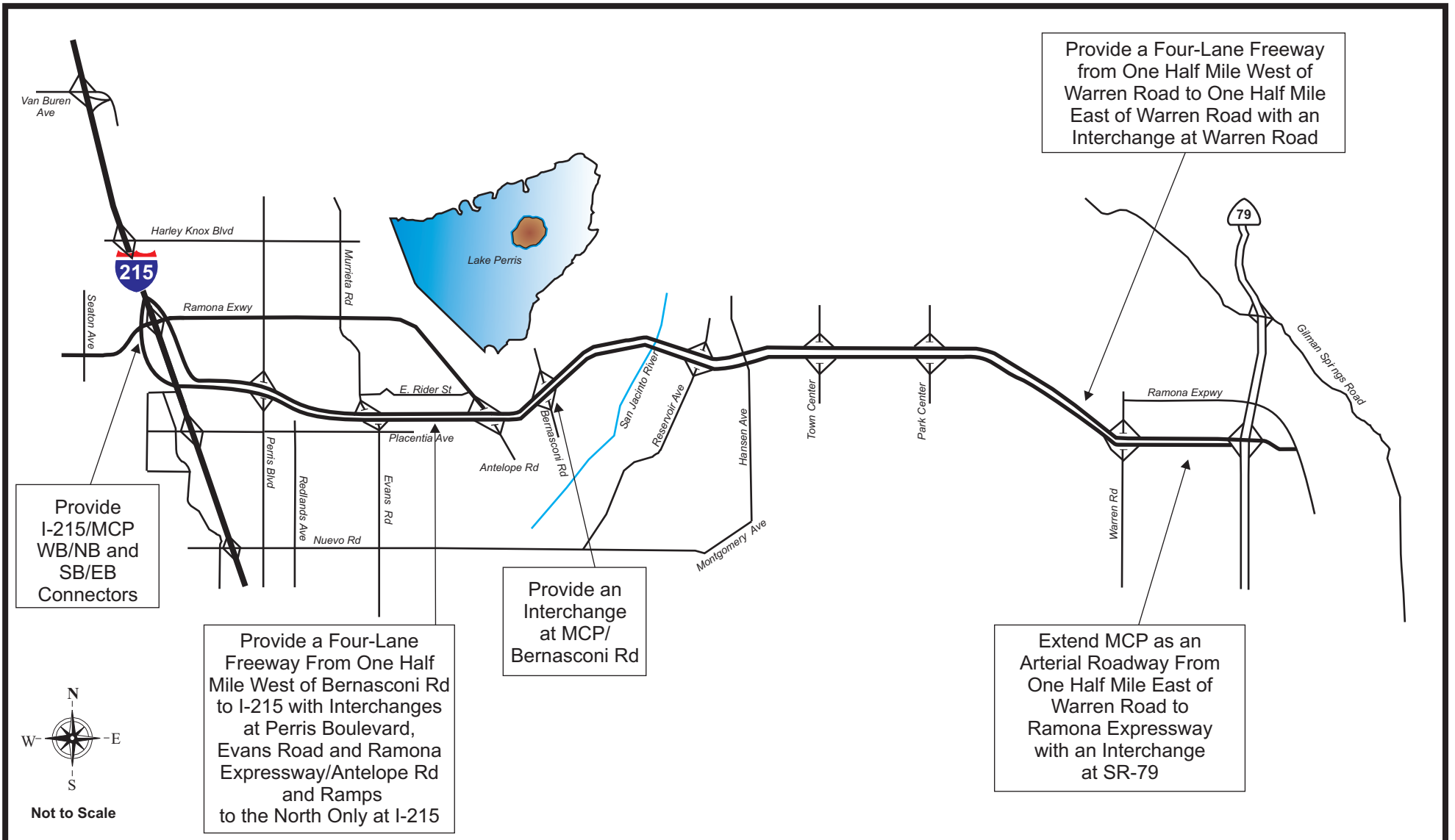

Mid County Parkway - Alternative 5 Modified Proposed Improvements: Future Year (2030)

Figure 9-3

LEGEND

- Existing or Proposed Arterial Roadway
- Existing or Proposed Freeway



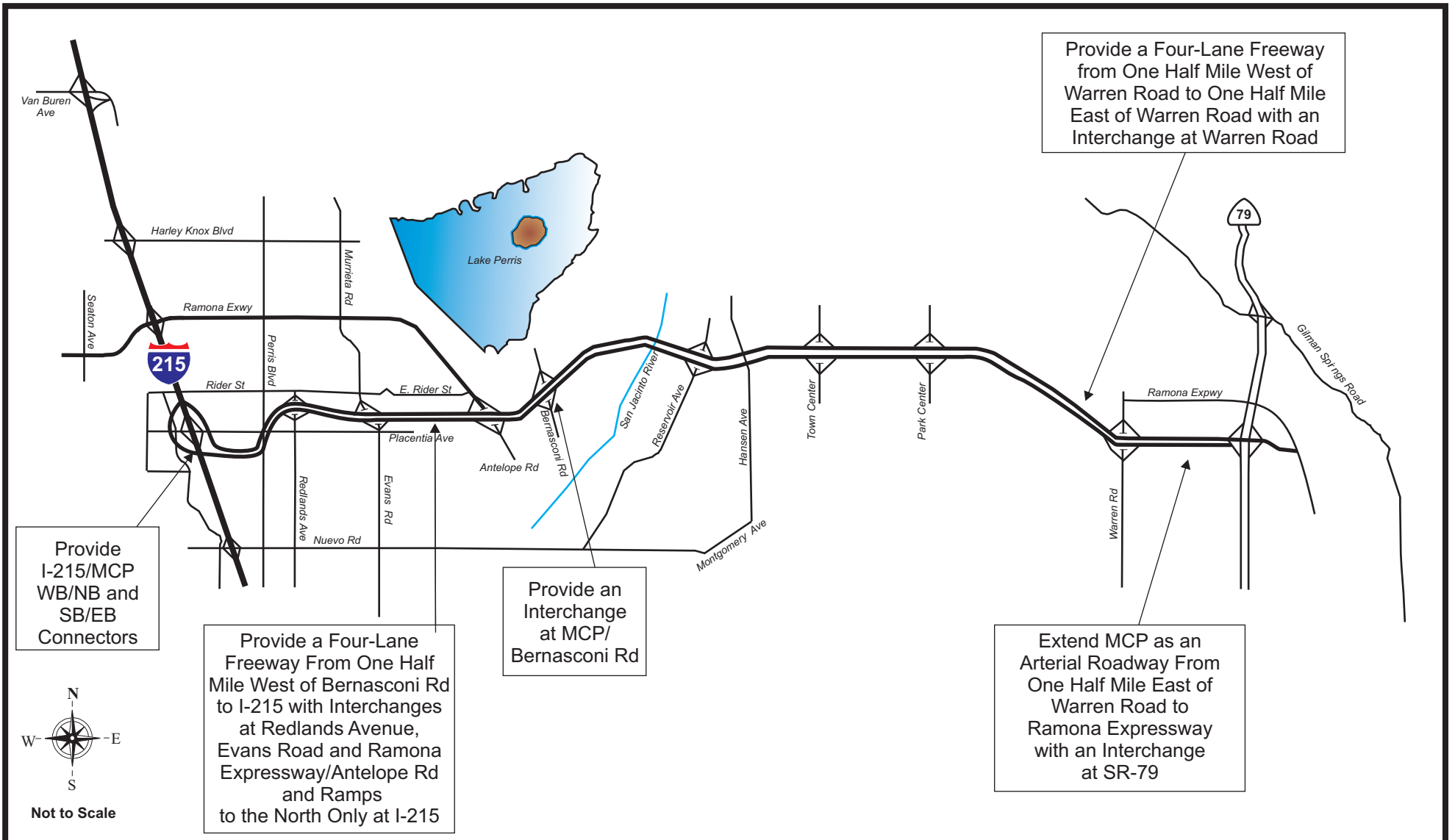

Mid County Parkway - Alternative 9 Modified Proposed Improvements: Future Year (2030)

Figure 9-4

LEGEND

- Existing or Proposed Arterial Roadway
- Existing or Proposed Freeway



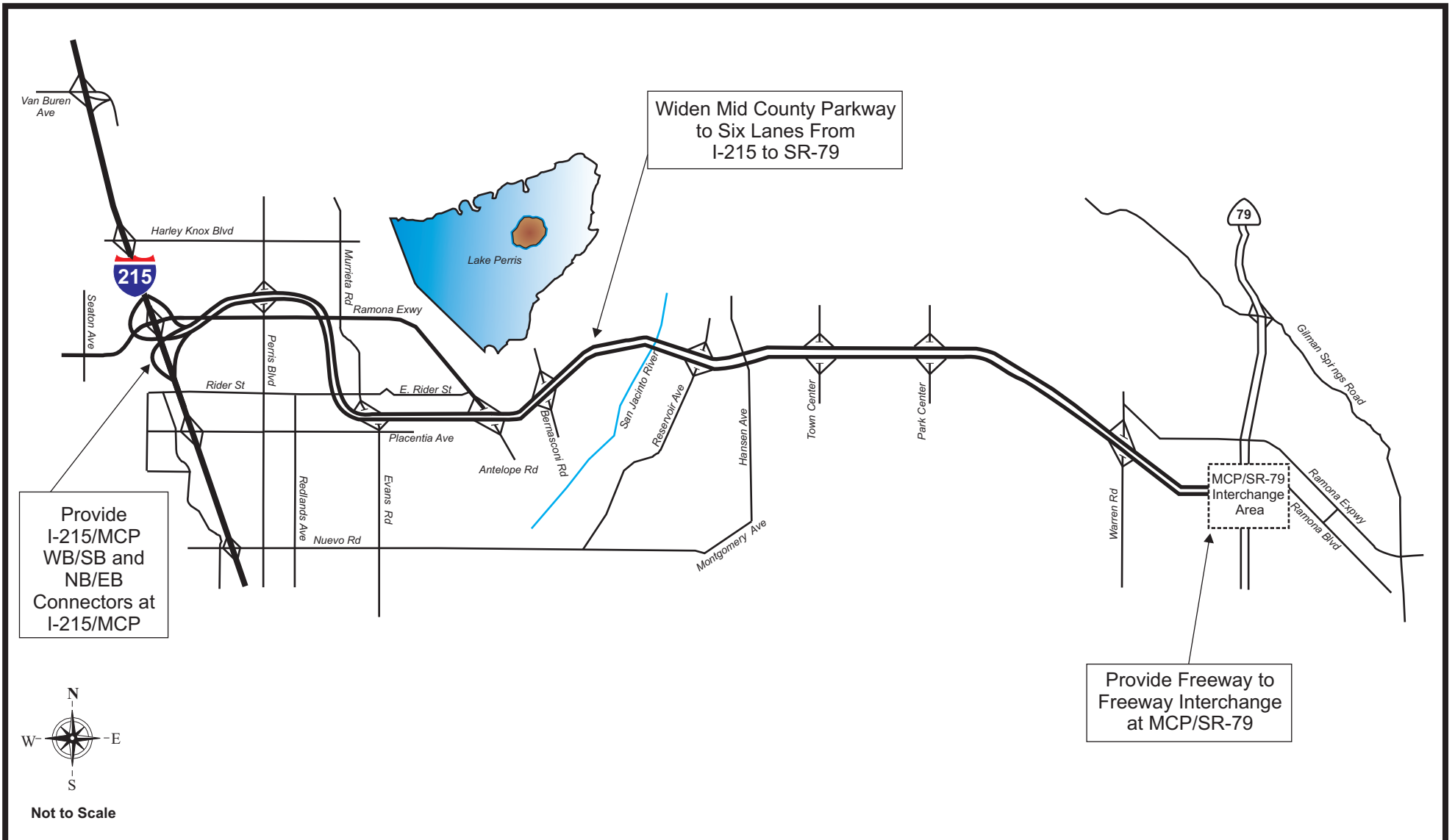

**Mid County Parkway - Alternative 4 Modified
Proposed Improvements: Horizon Year (2040)**

Figure 9-5

LEGEND

- Existing or Proposed Arterial Roadway
- == Existing or Proposed Freeway



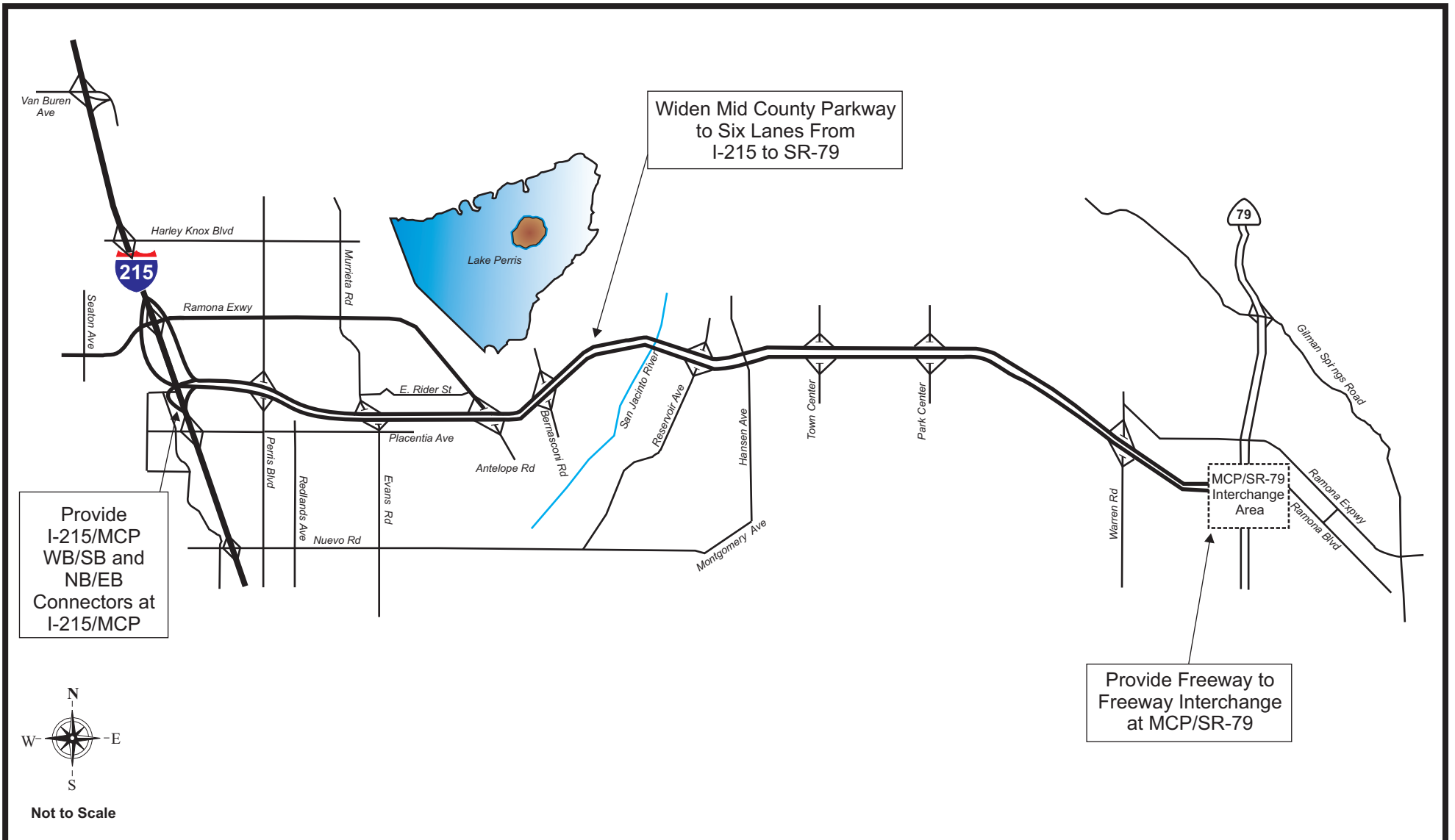



**Mid County Parkway - Alternative 5 Modified
Proposed Improvements: Horizon Year (2040)**

Figure 9-6

LEGEND

-  Existing or Proposed Arterial Roadway
-  Existing or Proposed Freeway



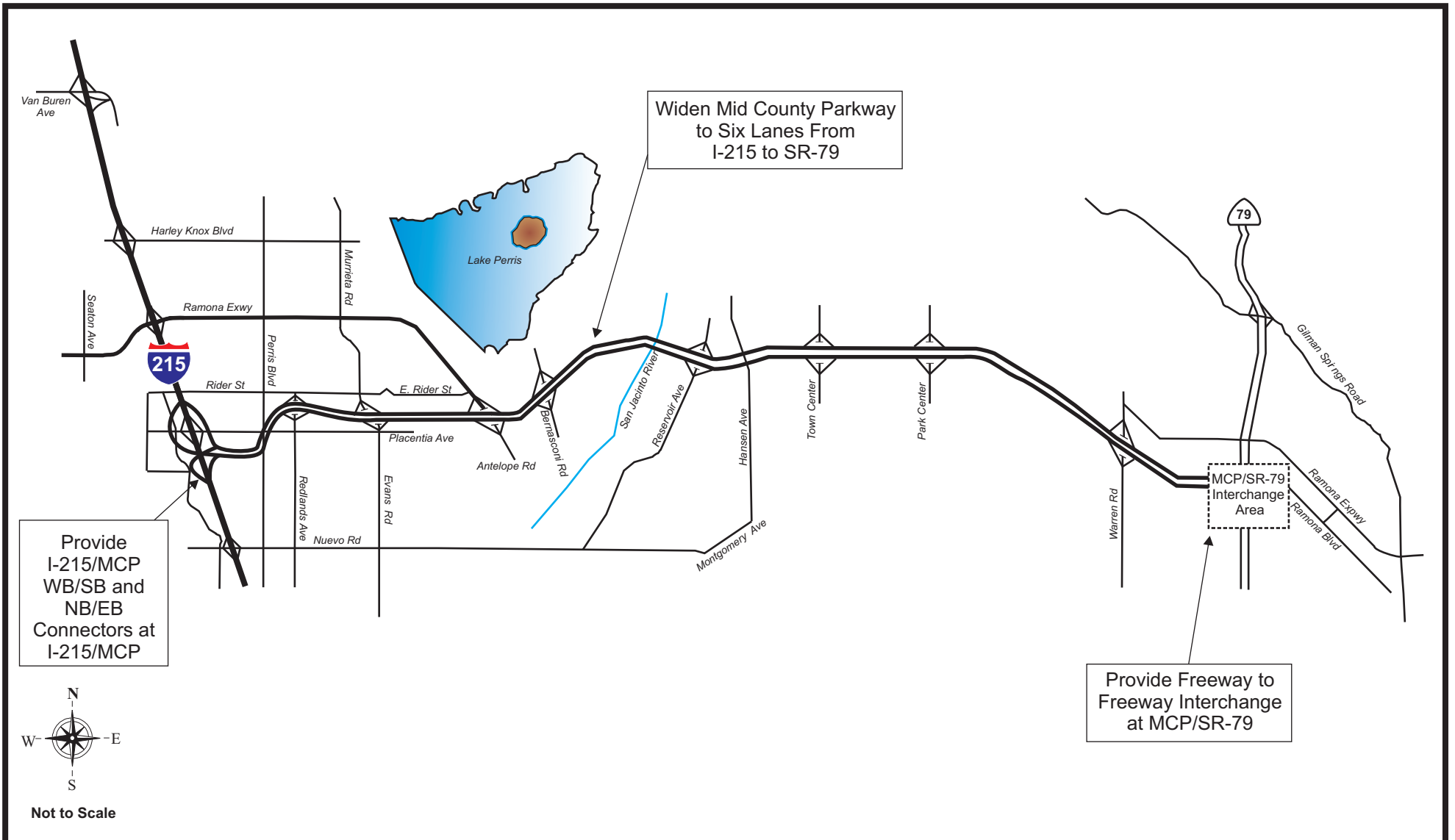

**Mid County Parkway - Alternative 9 Modified
Proposed Improvements: Horizon Year (2040)**

Figure 9-7

LEGEND

- Existing or Proposed Arterial Roadway
- == Existing or Proposed Freeway



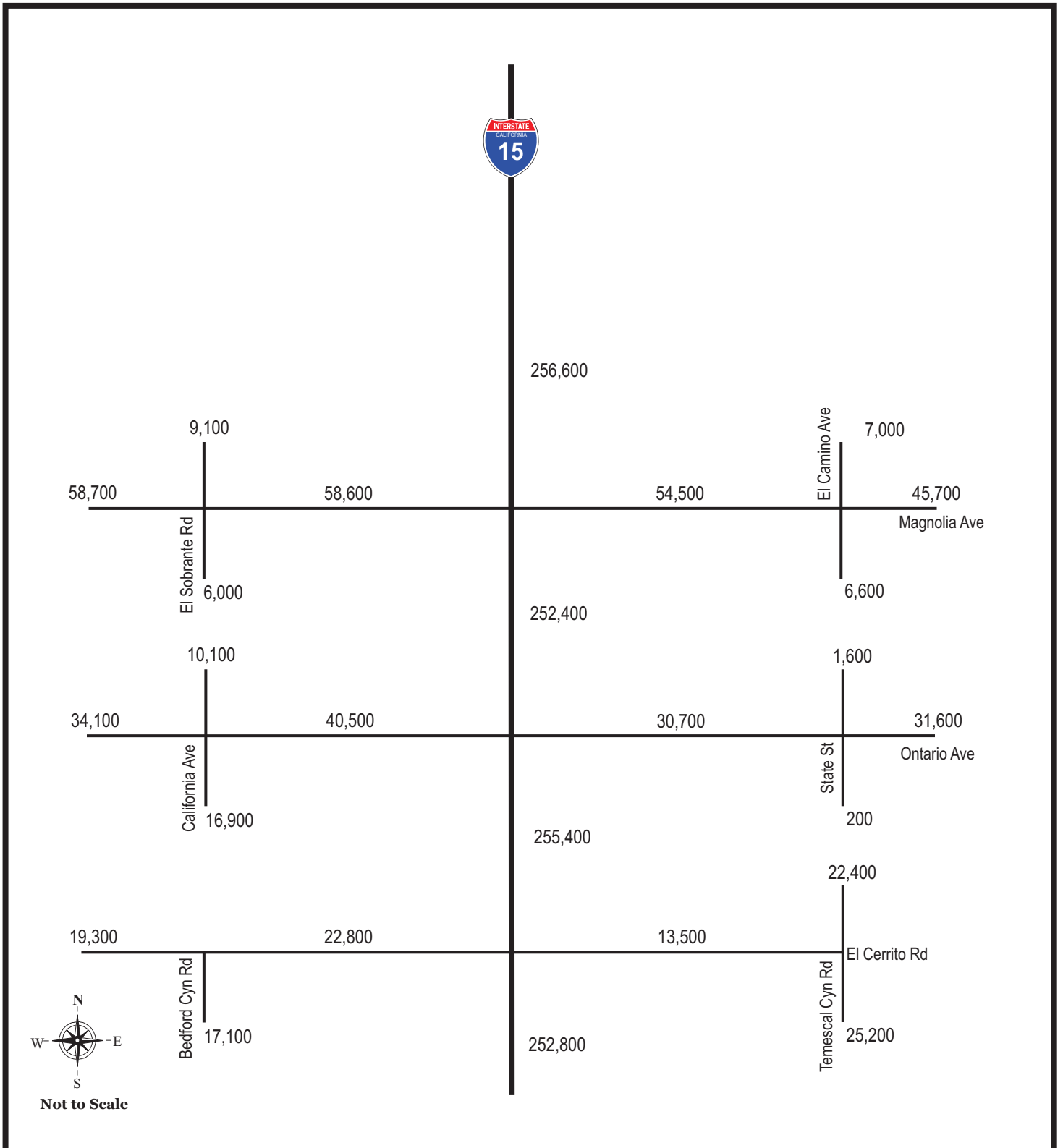

Future Year (2030) ADT - Freeway and Street Segments MCP Area - No Build

Figure 9-8a

Legend:

XX,XXX Average Daily Traffic



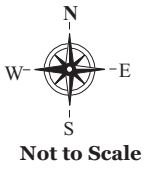
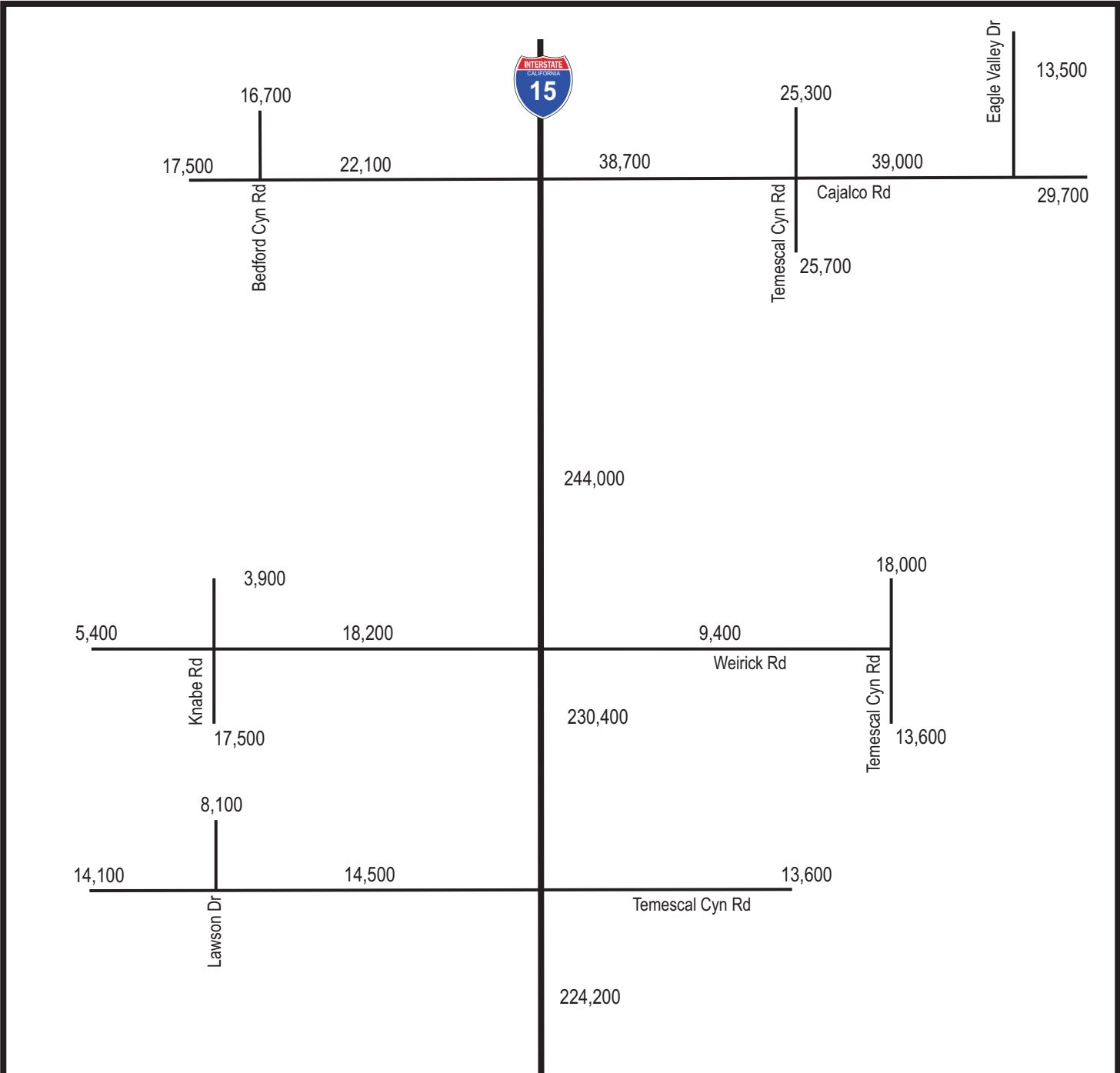

Future Year (2030) ADT - Freeway and Street Segments MCP Area - No Build

Figure 9-8b

Legend:
 XX,XXX Average Daily Traffic



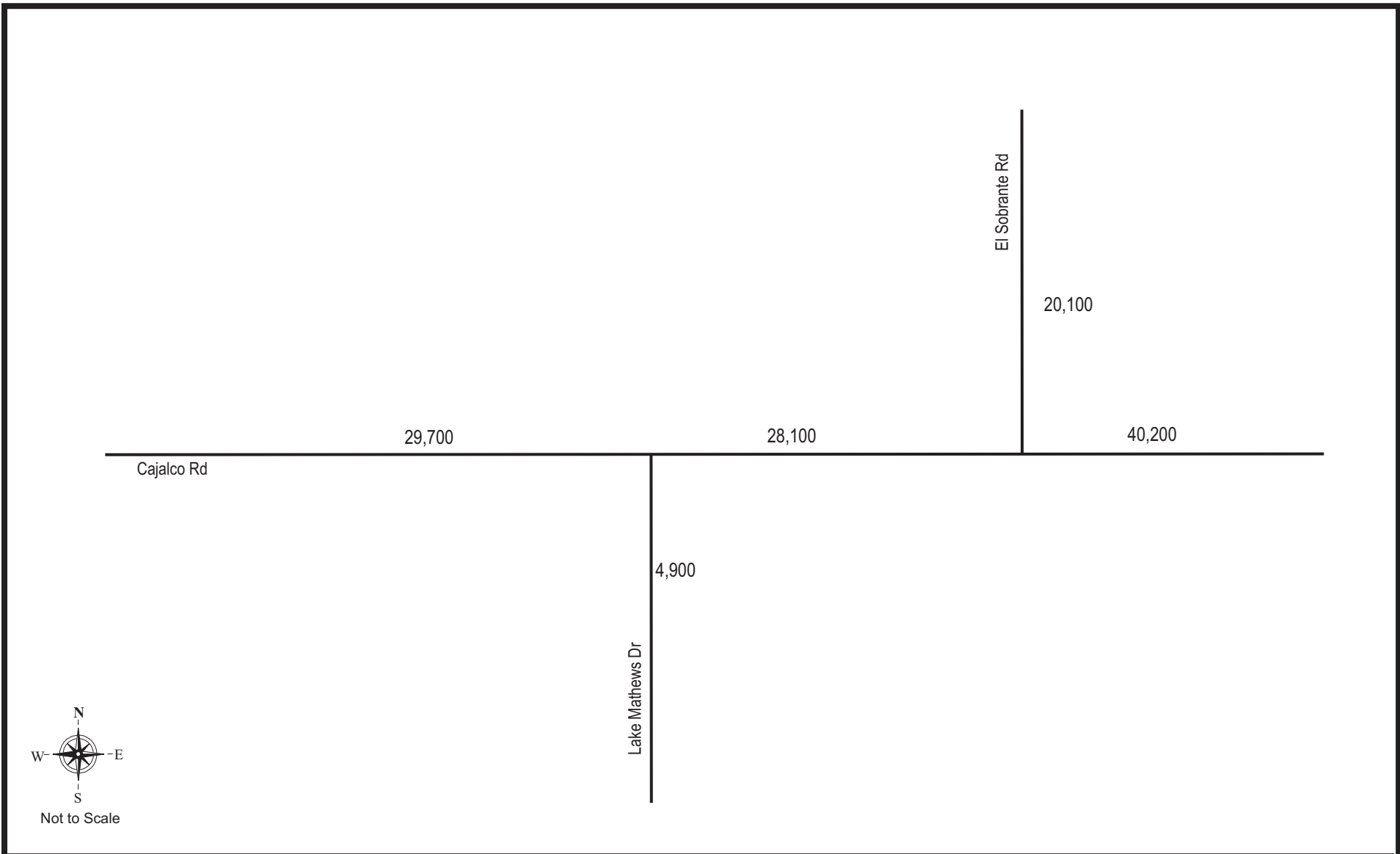

Future Year (2030) ADT - Freeway and Street Segments MCP Area - No Build

Figure 9-8c

Legend:

XX,XXX Average Daily Traffic



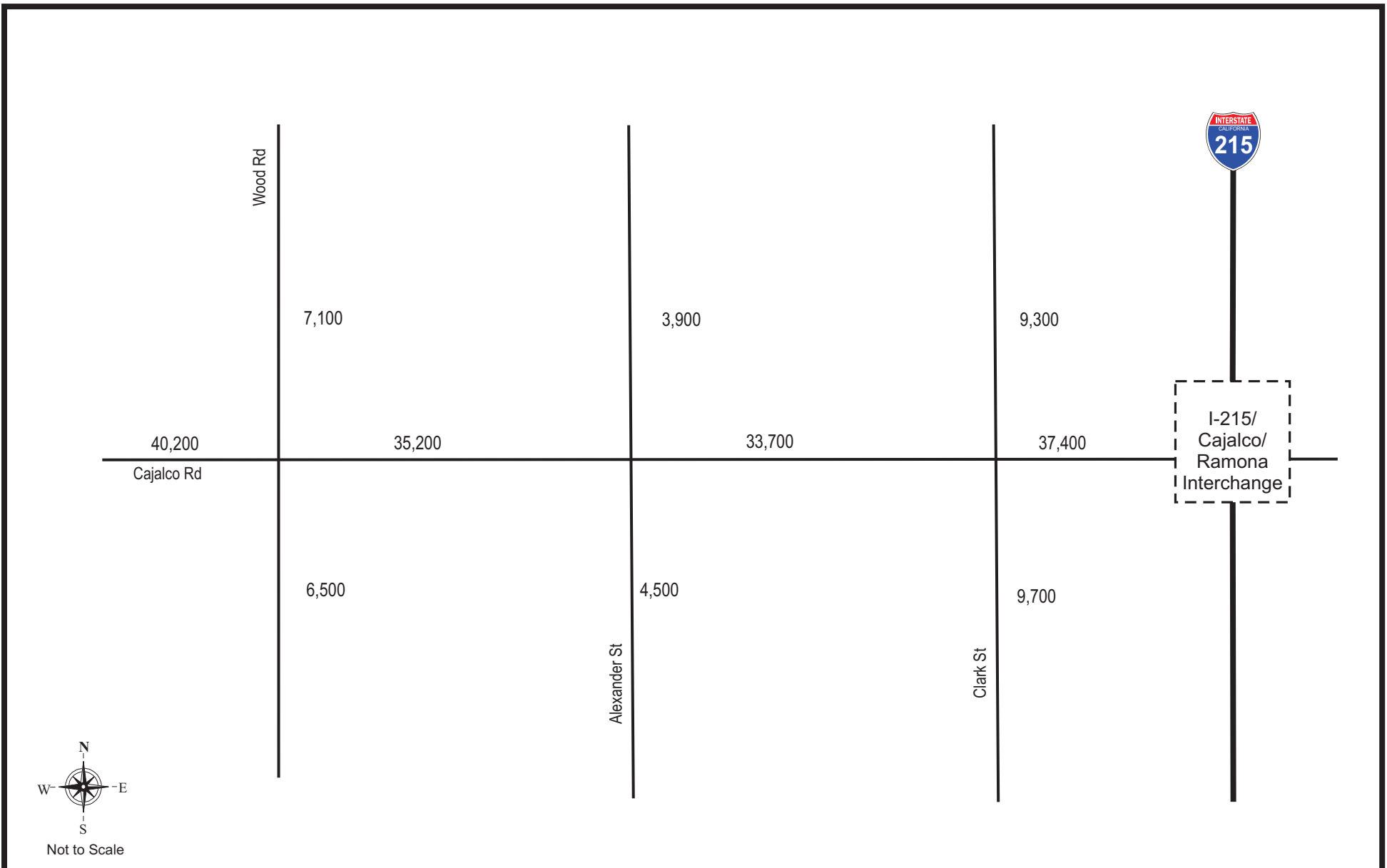

Future Year (2030) ADT - Freeway and Street Segments MCP Area - No Build

Figure 9-8d

Legend:

XX,XXX Average Daily Traffic



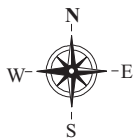
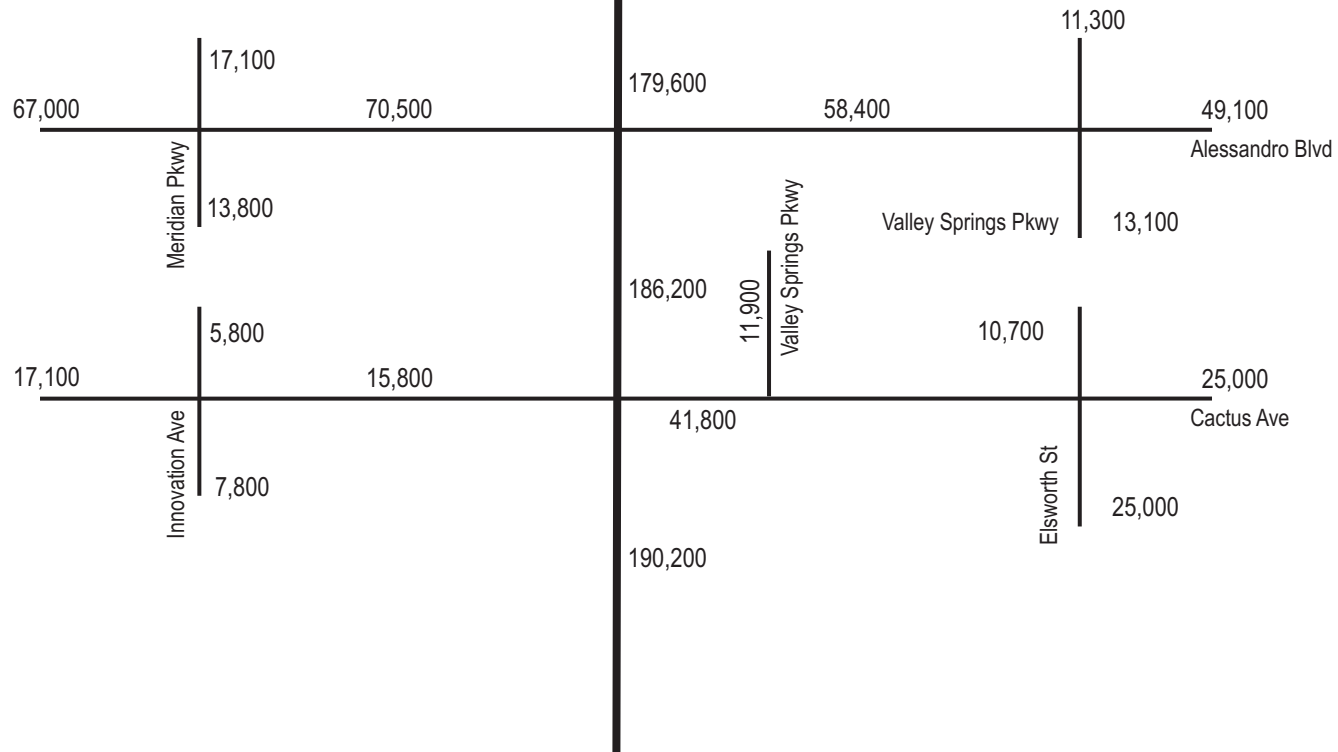

Not to Scale

Future Year (2030) ADT - Freeway and Street Segments MCP Area - No Build

Figure 9-8e

Legend:

XX,XXX Average Daily Traffic



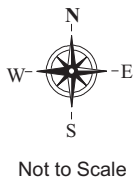

Future Year (2030) ADT - Freeway and Street Segments MCP Area - No Build

Figure 9-8f

Legend:

XX,XXX Average Daily Traffic



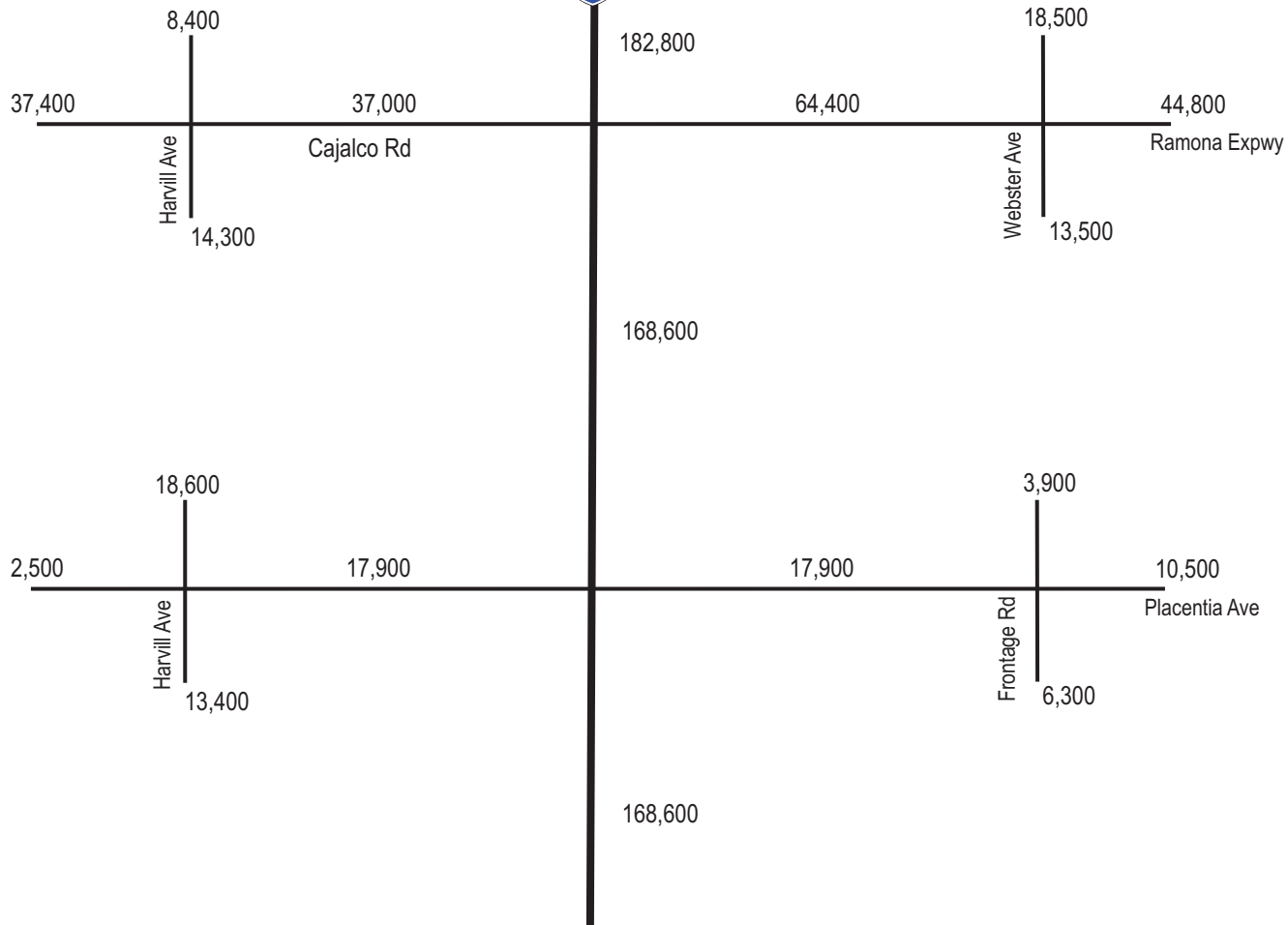

Future Year (2030) ADT - Freeway and Street Segments MCP Area - No Build

Figure 9-8g

Legend:

XX,XXX Average Daily Traffic





Not to Scale

Future Year (2030) ADT - Freeway and Street Segments MCP Area - No Build

Figure 9-8h

Legend:

XX,XXX Average Daily Traffic



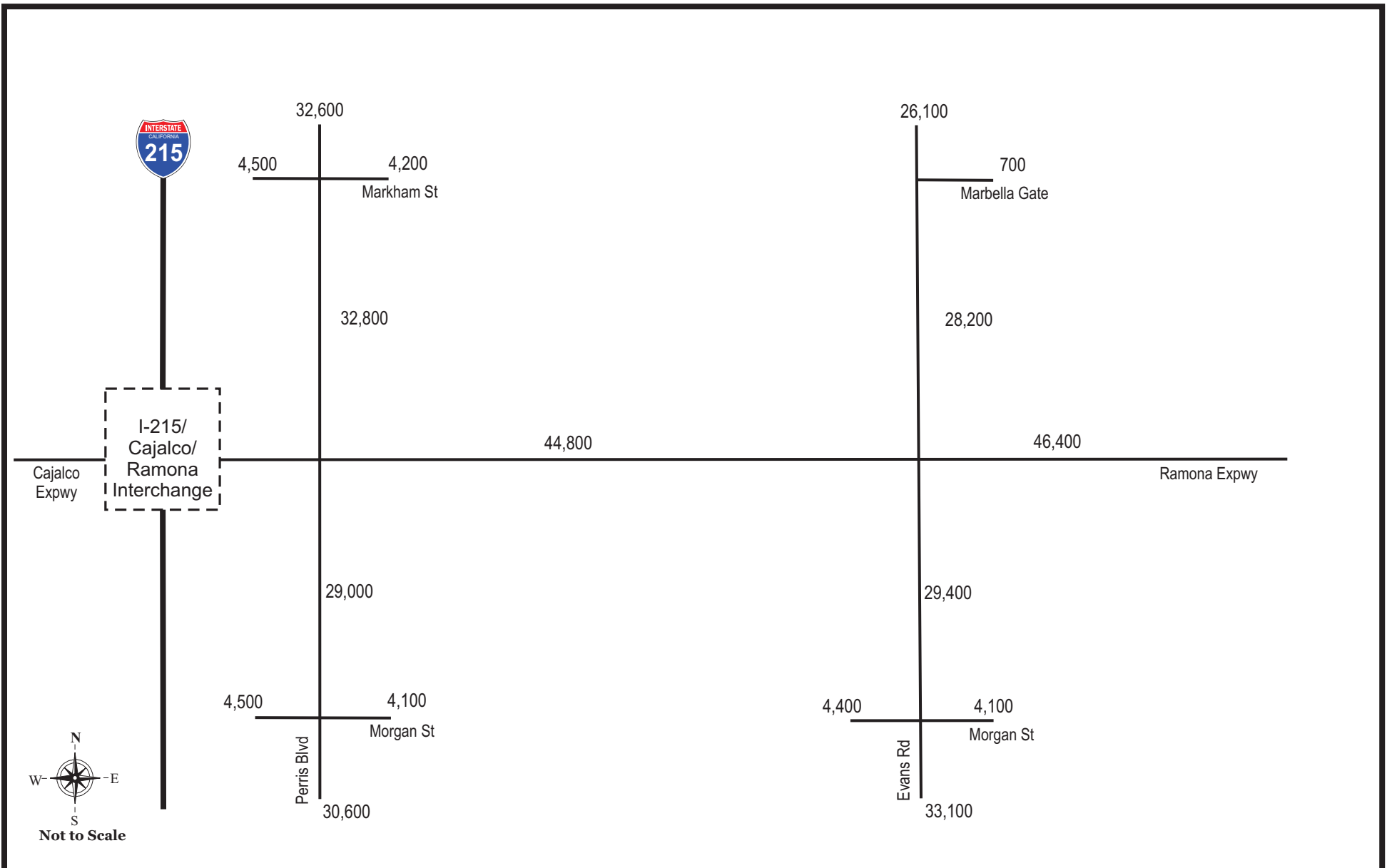

Future Year (2030) ADT - Freeway and Street Segments MCP Area - No Build

Figure 9-8i

Legend:

XX,XXX Average Daily Traffic



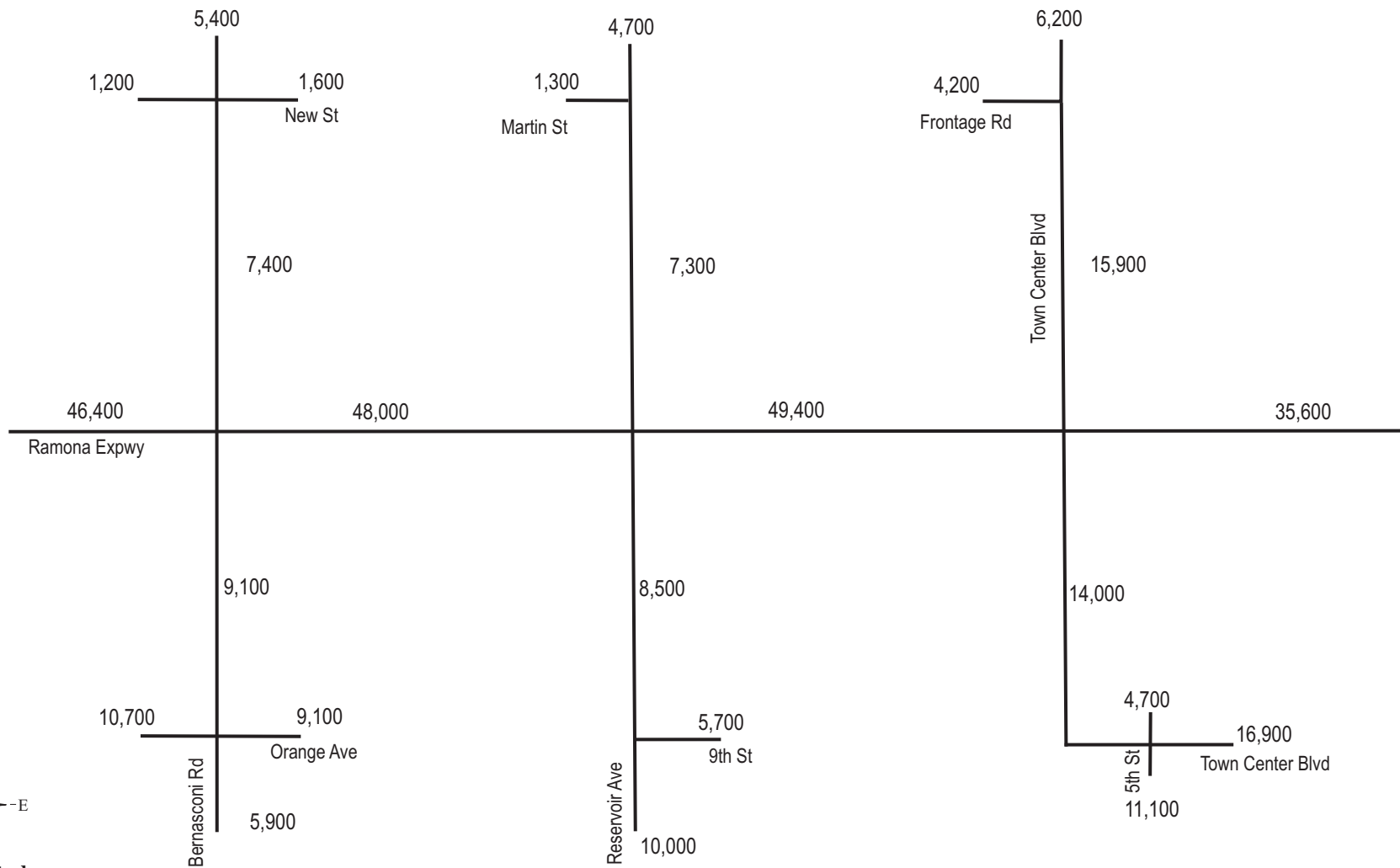

Future Year (2030) ADT - Freeway and Street Segments MCP Area - No Build

Figure 9-8j

Legend:

XX,XXX Average Daily Traffic



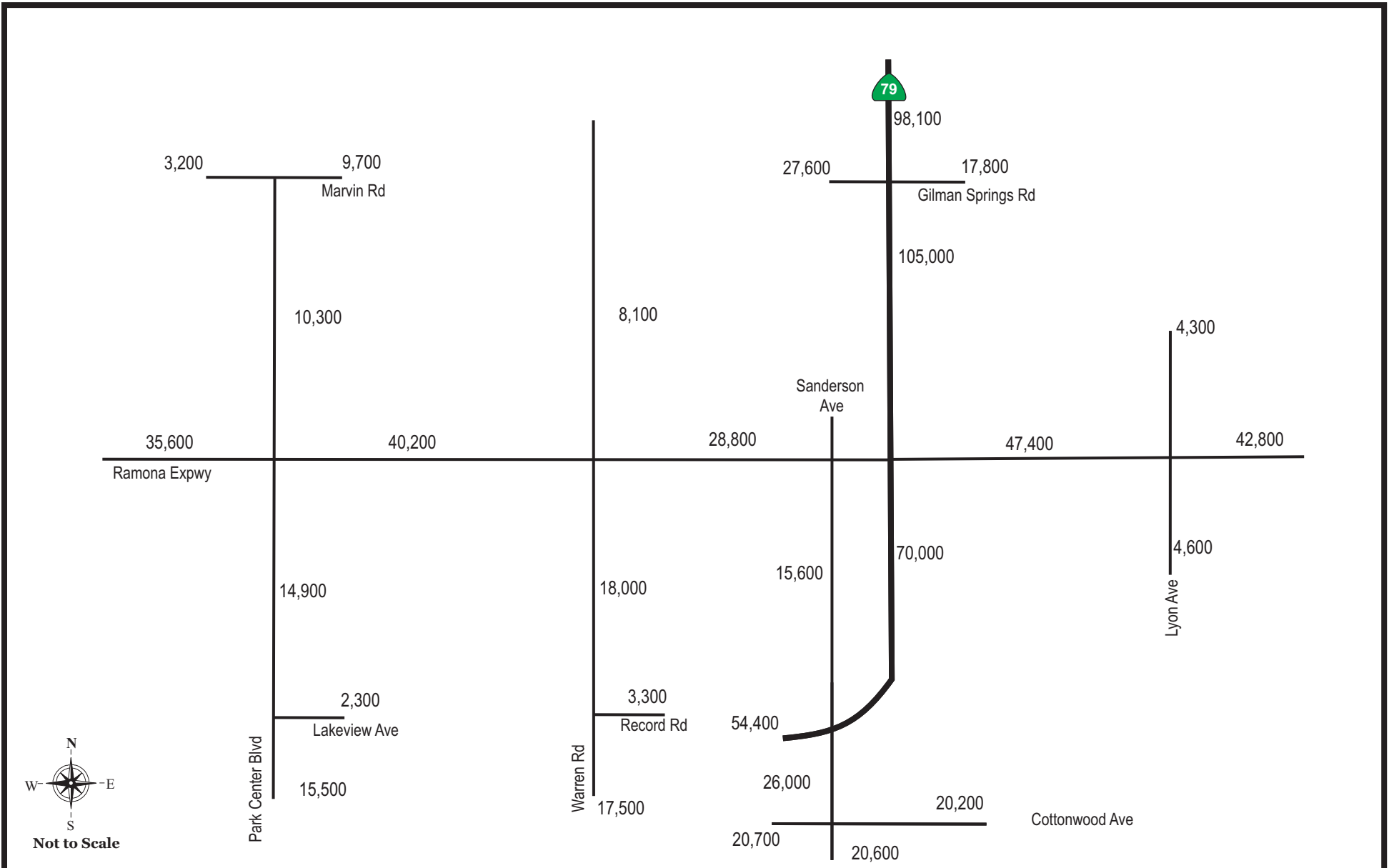

Future Year (2030) ADT - Freeway and Street Segments MCP Area - No Build

Figure 9-8k

Legend:

XX,XXX Average Daily Traffic



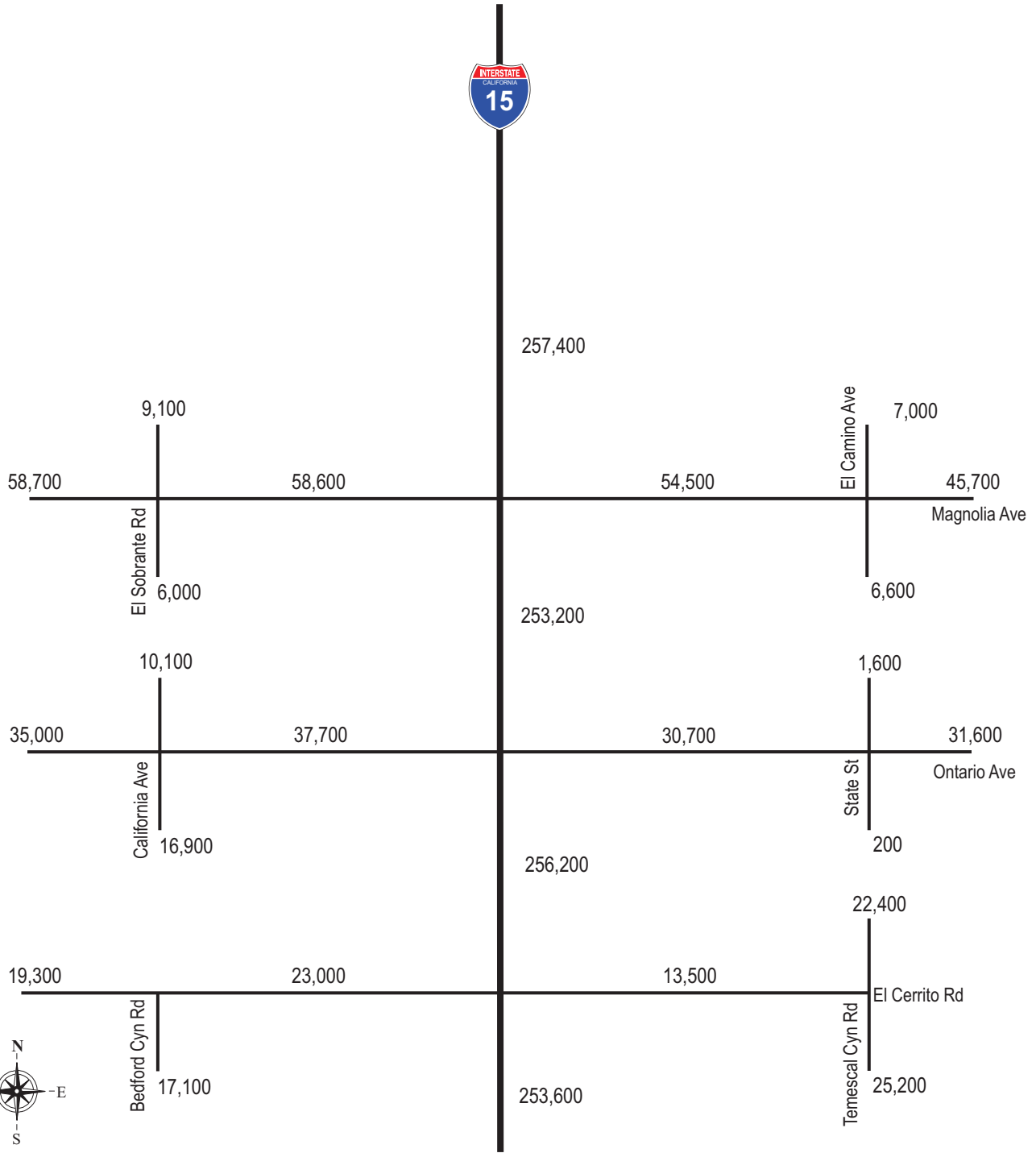

Not to Scale

Future Year (2030) ADT - Freeway and Street Segments MCP Area - Alternative 4 Modified

Figure 9-9a

Legend:

XX,XXX Average Daily Traffic



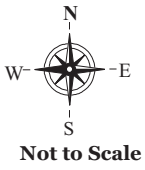
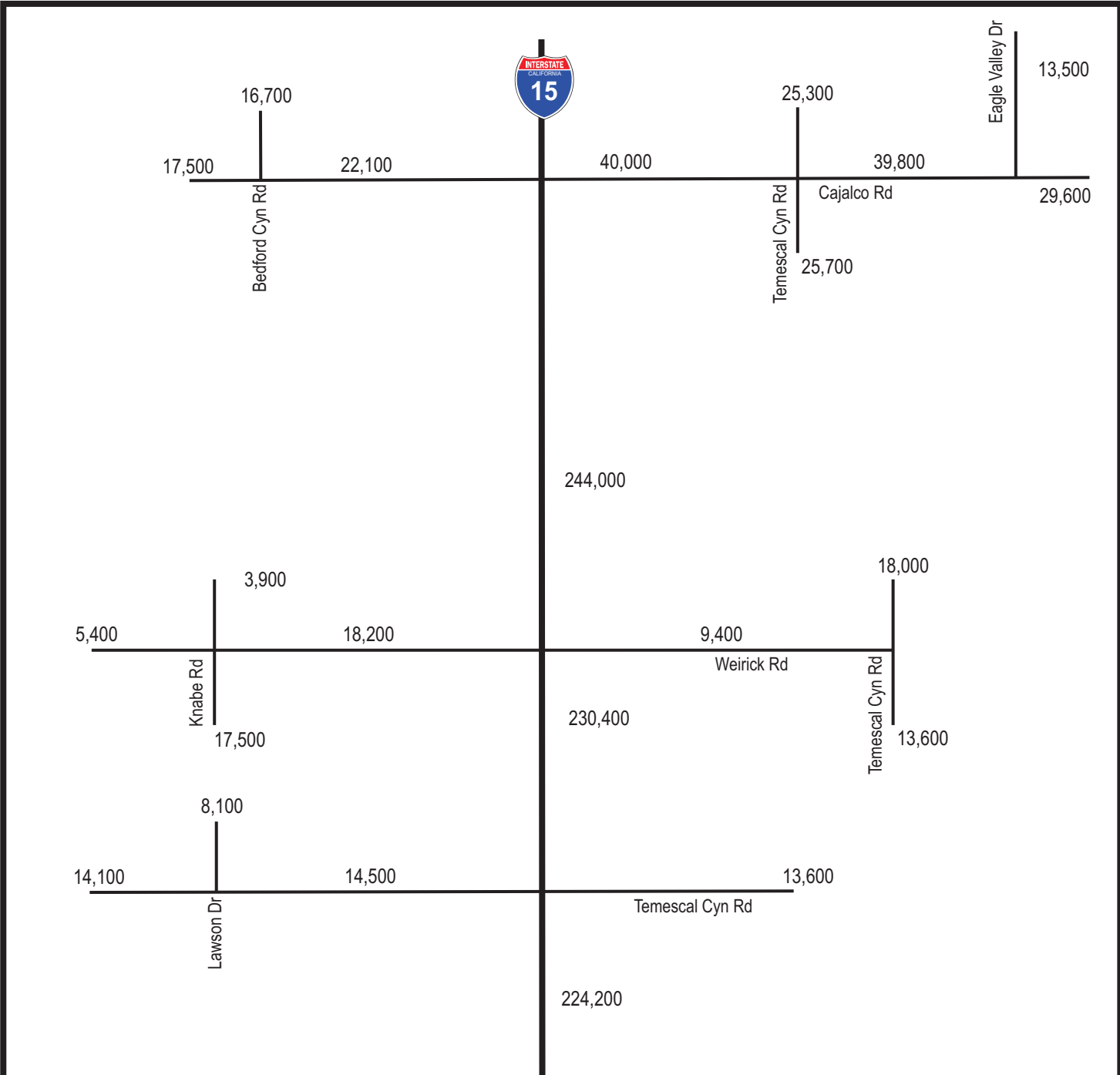

Future Year (2030) ADT - Freeway and Street Segments MCP Area - Alternative 4 Modified

Figure 9-9b

Legend:
 XX,XXX Average Daily Traffic





Future Year (2030) ADT - Freeway and Street Segments MCP Area - Alternative 4 Modified

Figure 9-9c

Legend:

XX,XXX Average Daily Traffic



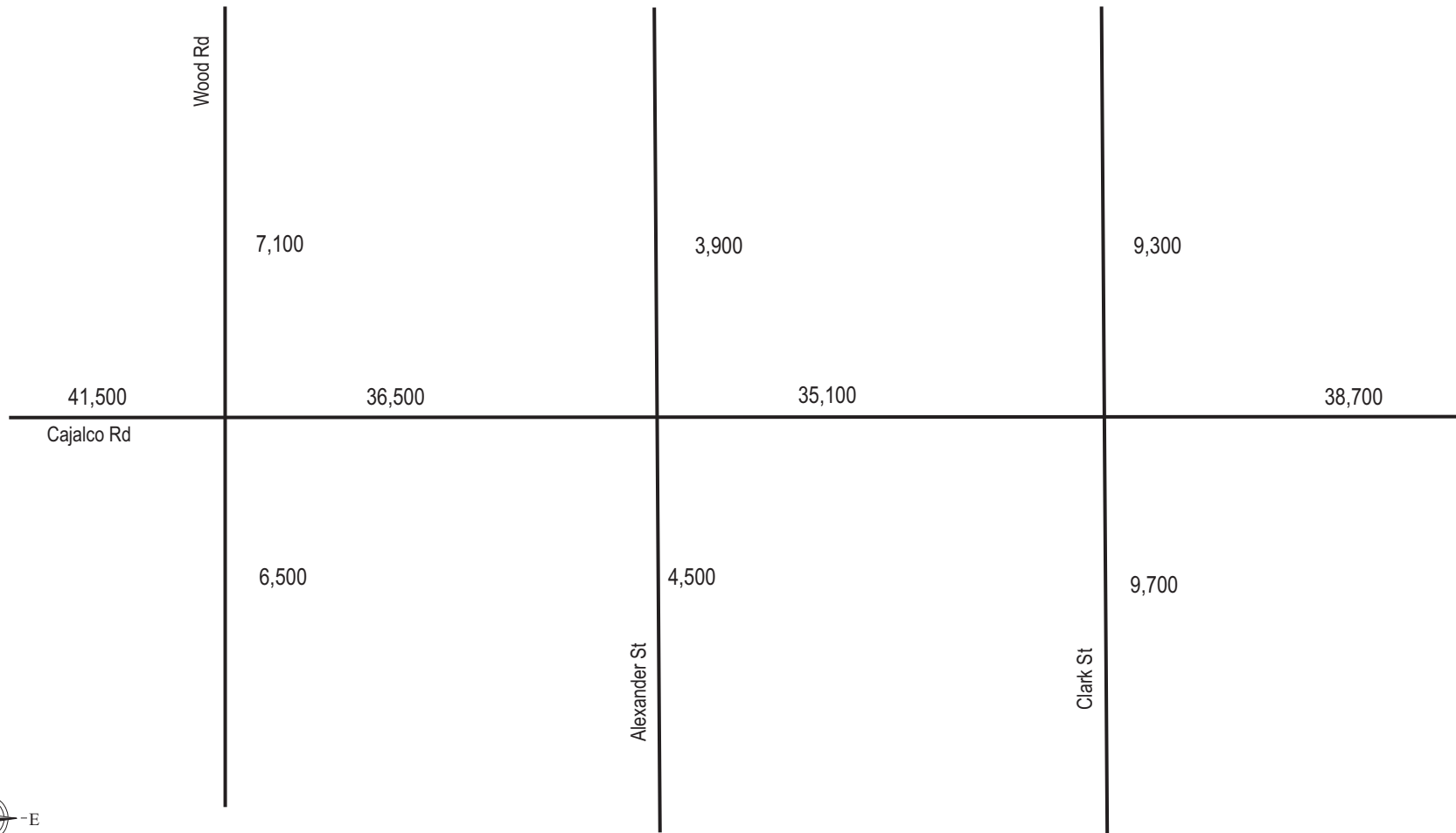

Future Year (2030) ADT - Freeway and Street Segments MCP Area - Alternative 4 Modified

Figure 9-9d

Legend:

XX,XXX Average Daily Traffic



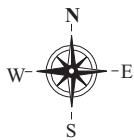
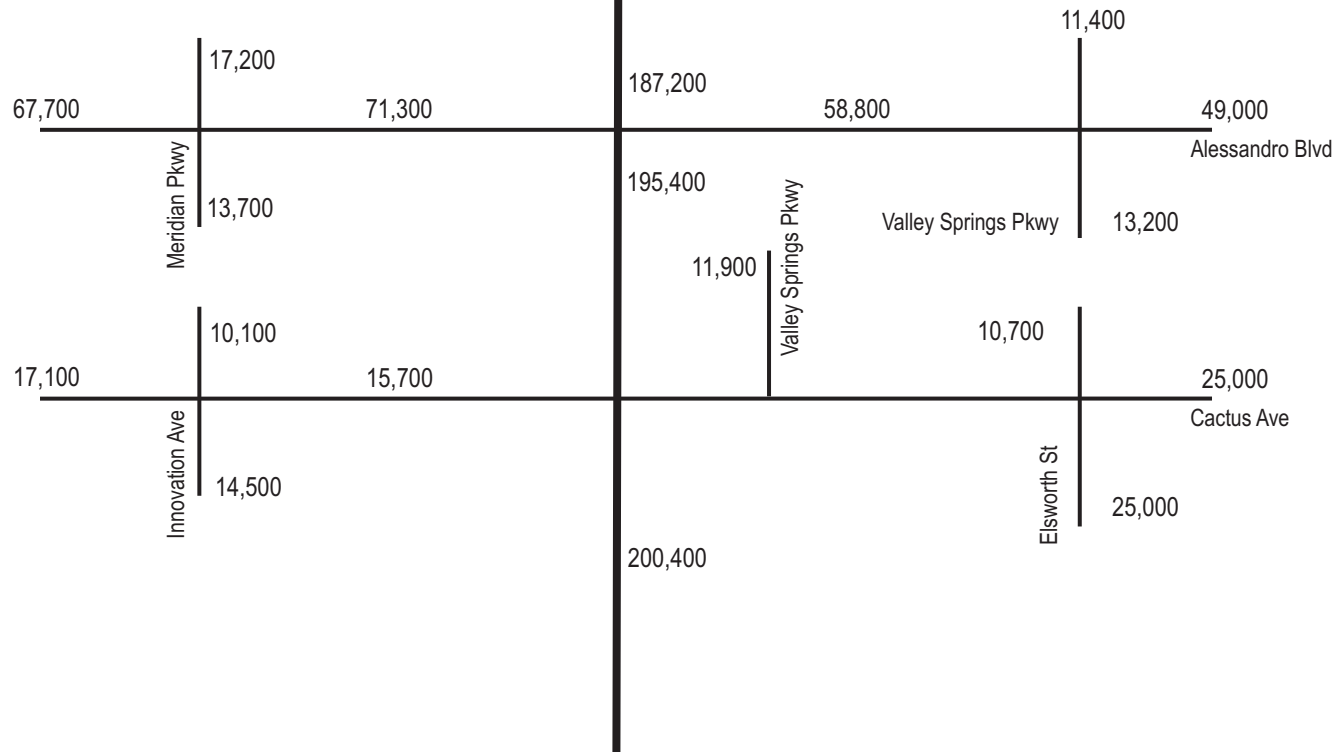

Not to Scale

Future Year (2030) ADT - Freeway and Street Segments MCP Area - Alternative 4 Modified

Figure 9-9e

Legend:

XX,XXX Average Daily Traffic





Not to Scale

Future Year (2030) ADT - Freeway and Street Segments MCP Area - Alternative 4 Modified

Figure 9-9f

Legend:

XX,XXX Average Daily Traffic



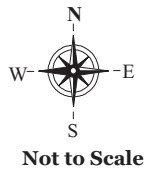
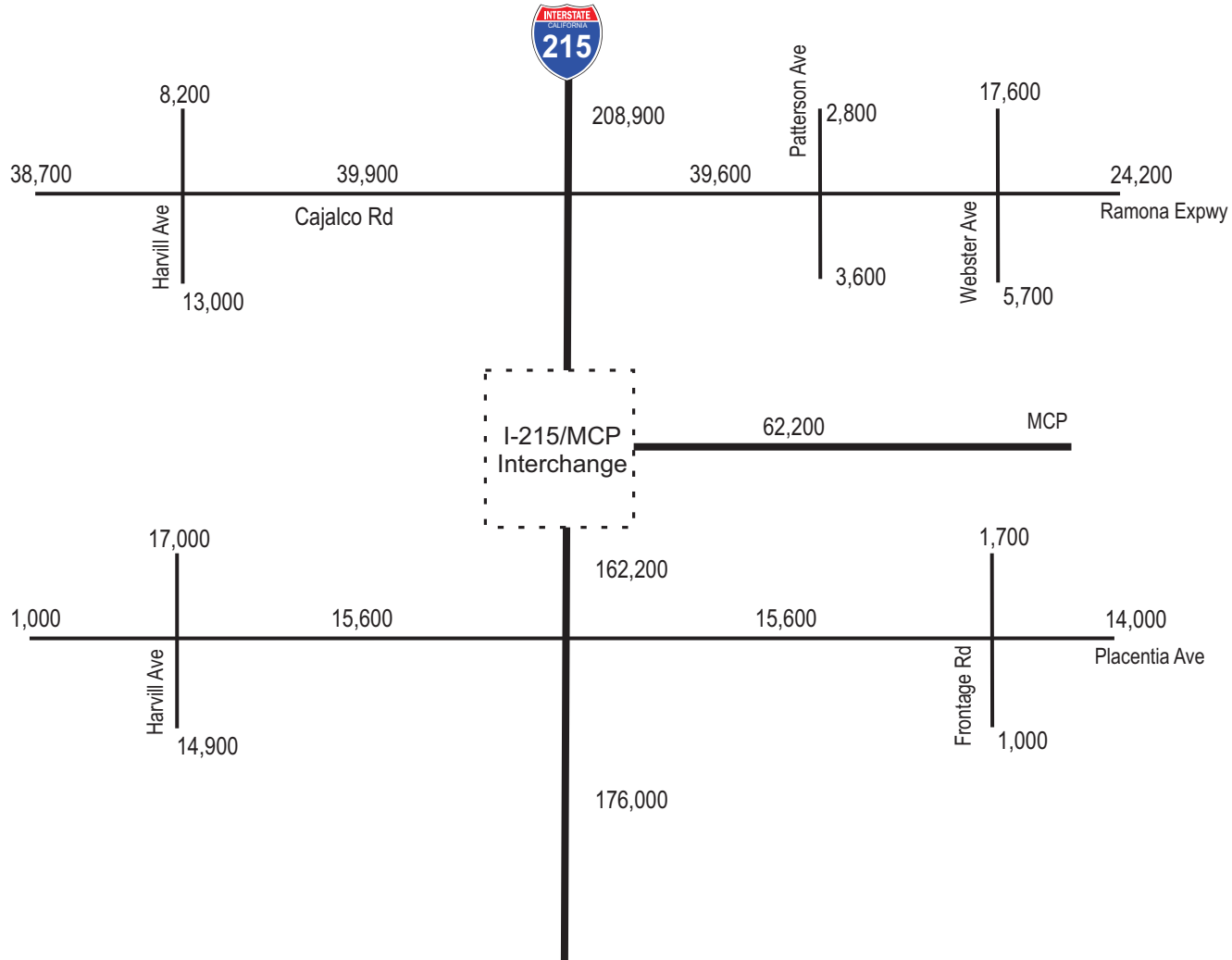

Future Year (2030) ADT - Freeway and Street Segments MCP Area - Alternative 4 Modified

Figure 9-9g

Legend:

XX,XXX Average Daily Traffic





Not to Scale

Future Year (2030) ADT - Freeway and Street Segments MCP Area - Alternative 4 Modified

Figure 9-9h

Legend:

XX,XXX Average Daily Traffic



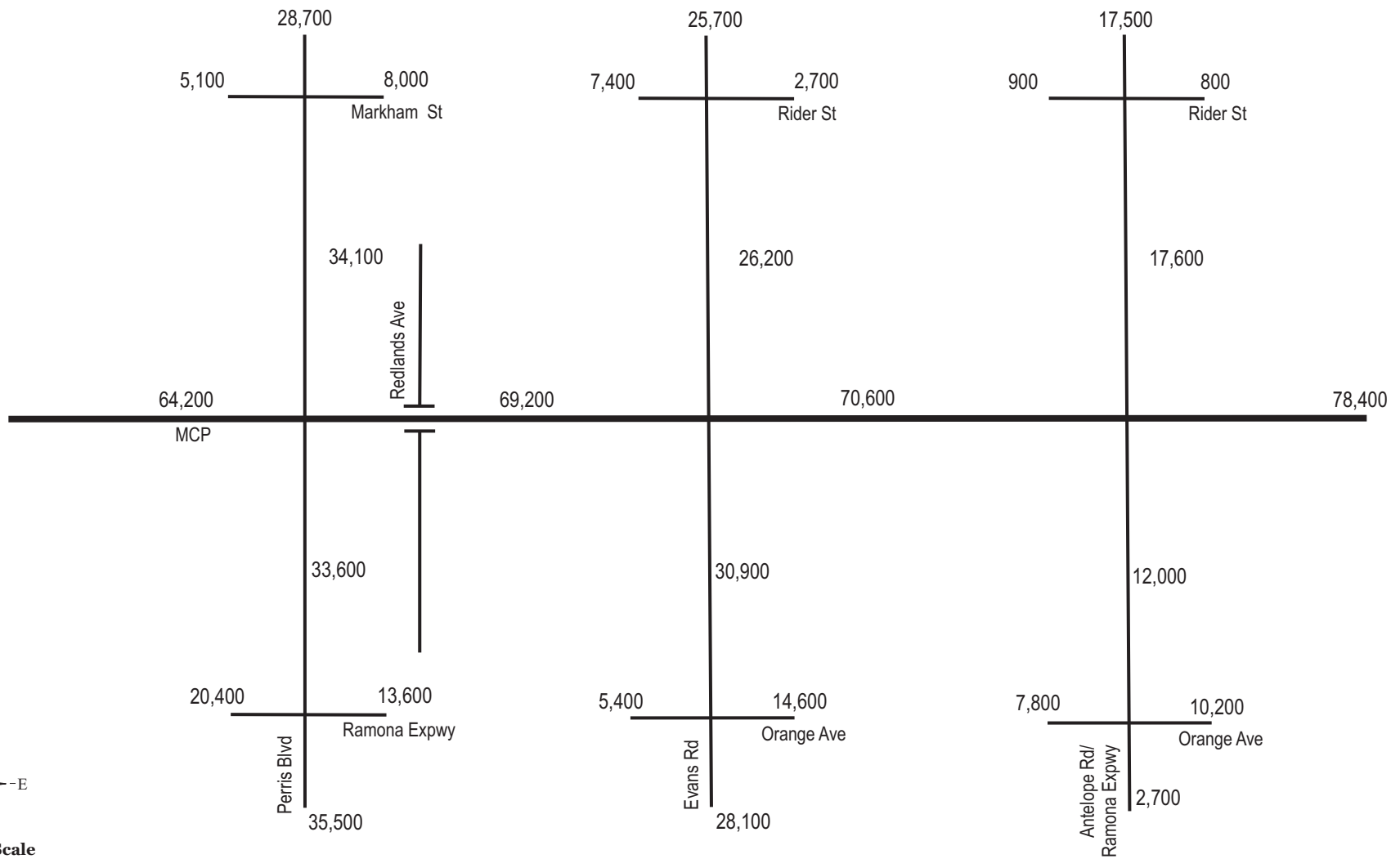

Future Year (2030) ADT - Freeway and Street Segments MCP Area - Alternative 4 Modified

Figure 9-9i

Legend:

XX,XXX Average Daily Traffic



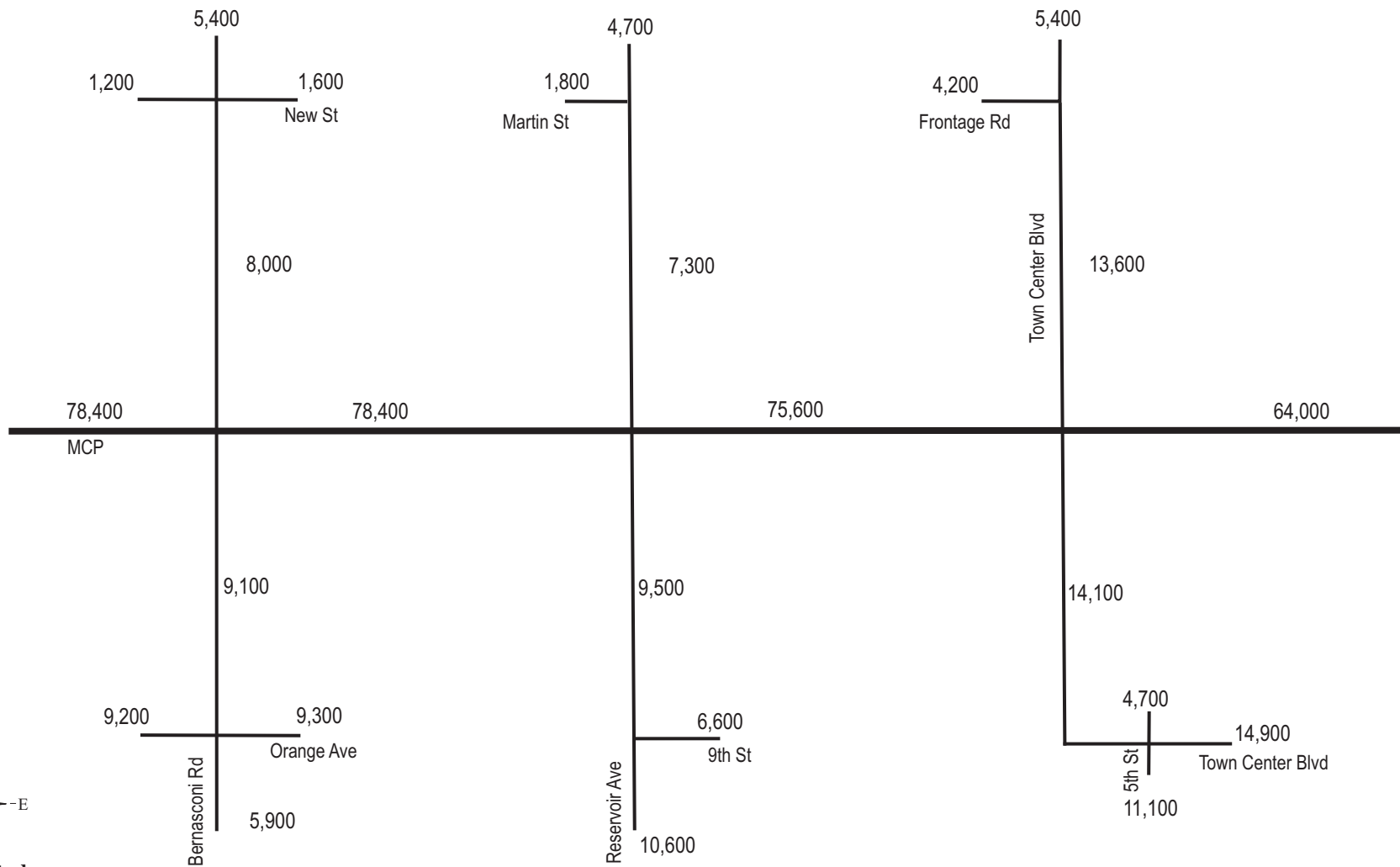

Future Year (2030) ADT - Freeway and Street Segments MCP Area - Alternative 4 Modified

Figure 9-9j

Legend:

XX,XXX Average Daily Traffic



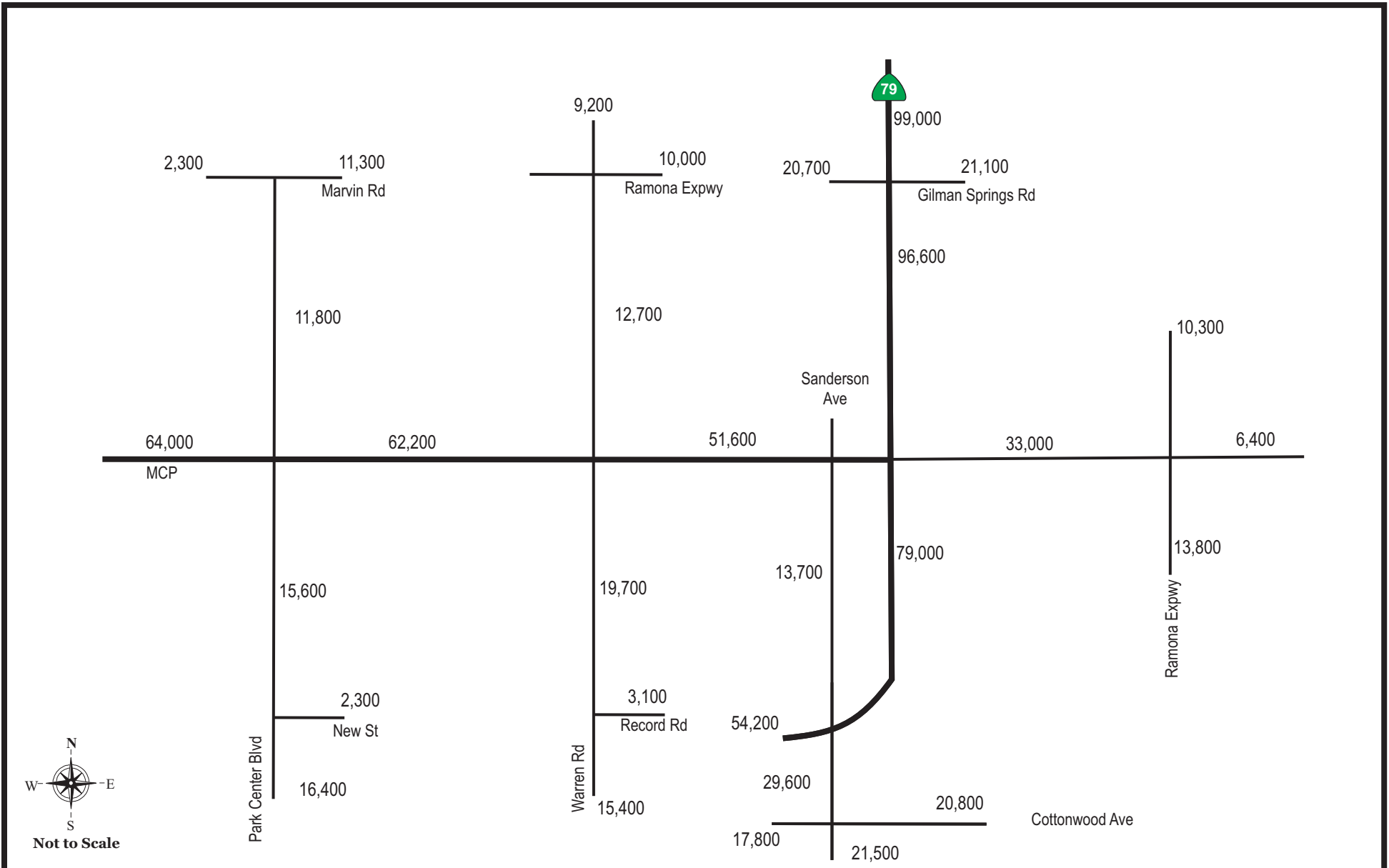

Future Year (2030) ADT - Freeway and Street Segments MCP Area - Alternative 4 Modified

Figure 9-9k

Legend:

XX,XXX Average Daily Traffic



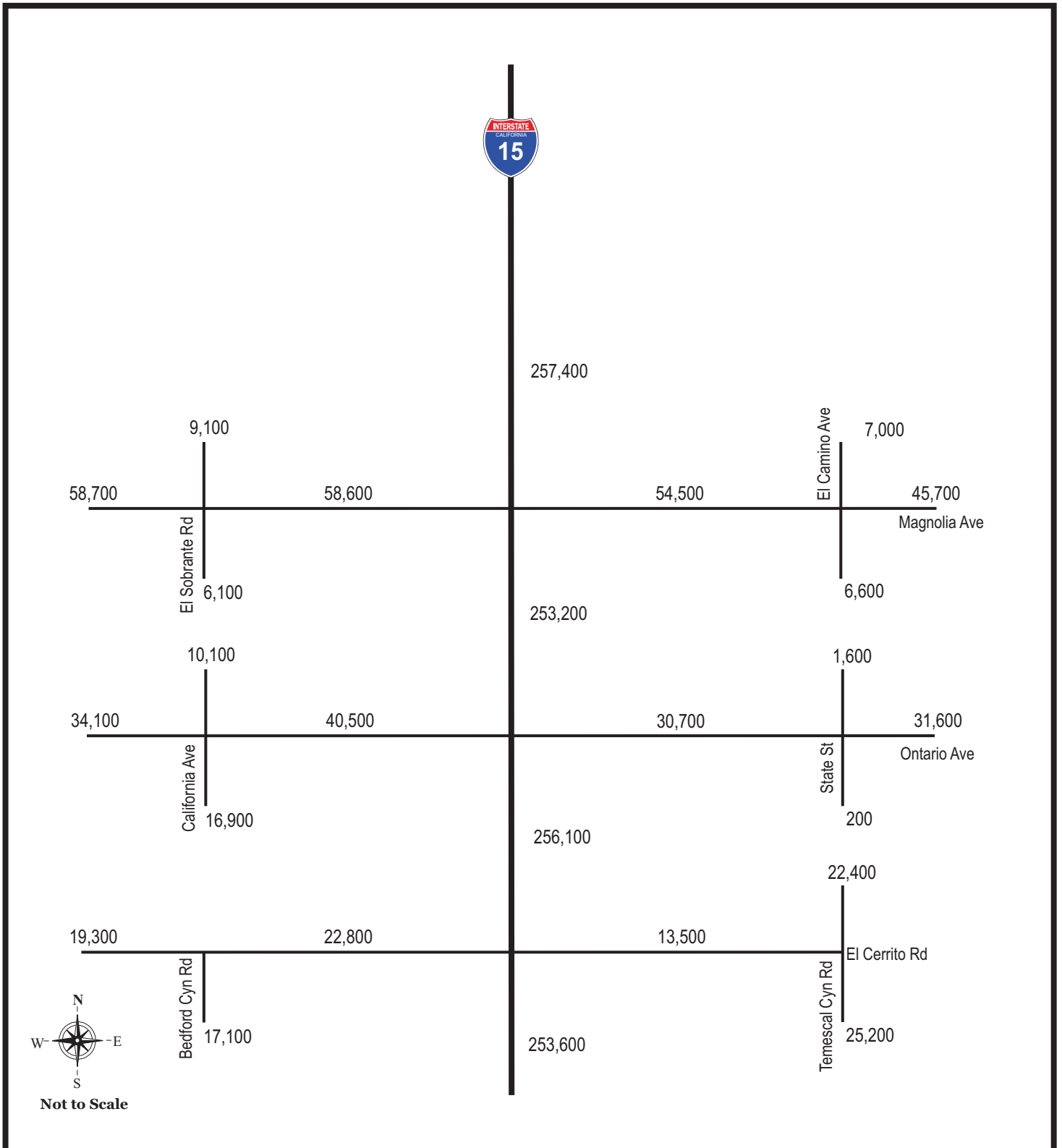

Future Year (2030) ADT - Freeway and Street Segments MCP Area - Alternative 5 Modified

Figure 9-10a

Legend:

XX,XXX Average Daily Traffic



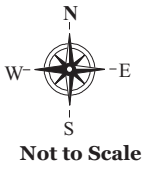
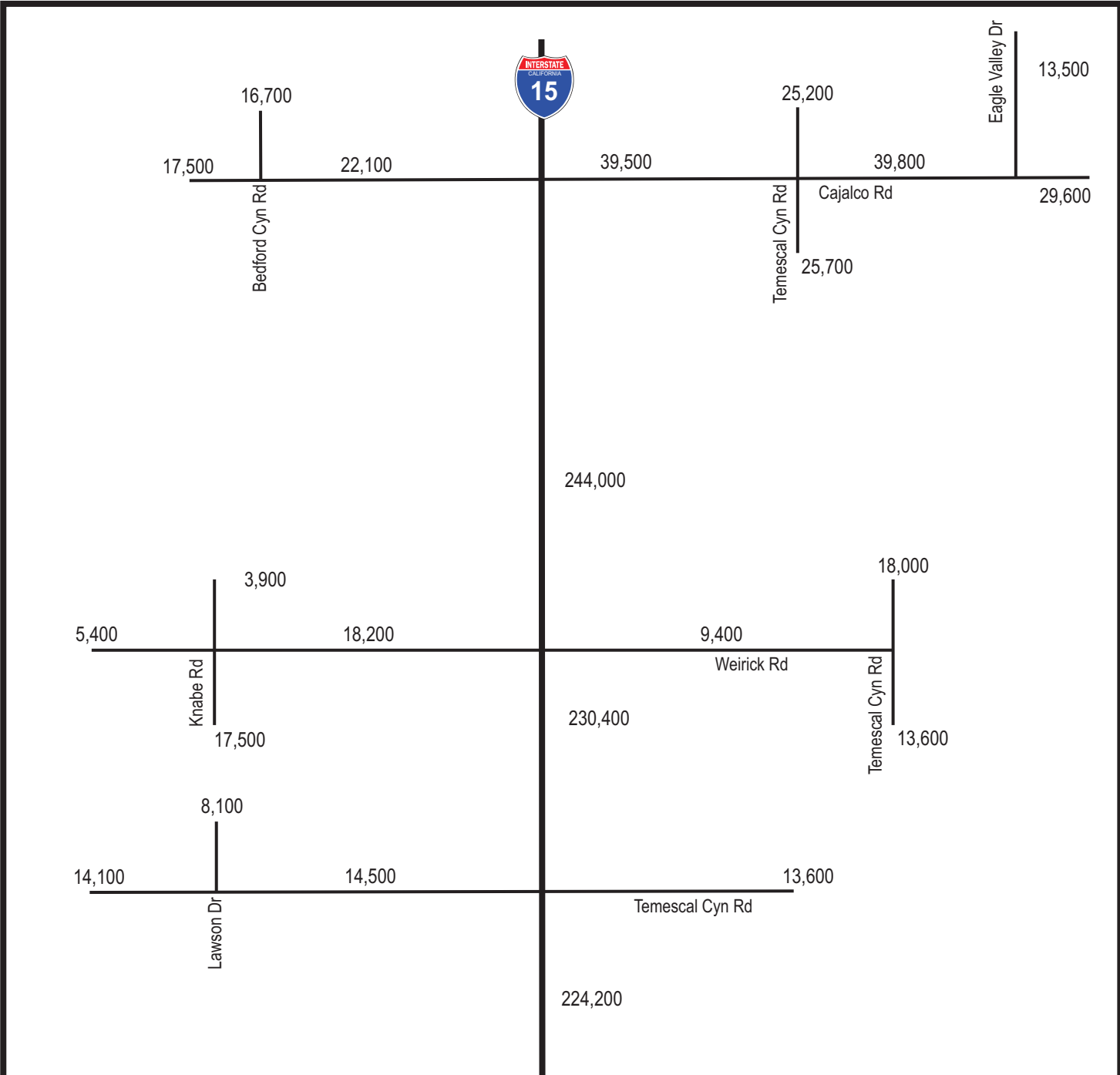

Future Year (2030) ADT - Freeway and Street Segments MCP Area - Alternative 5 Modified

Figure 9-10b

Legend:
 XX,XXX Average Daily Traffic



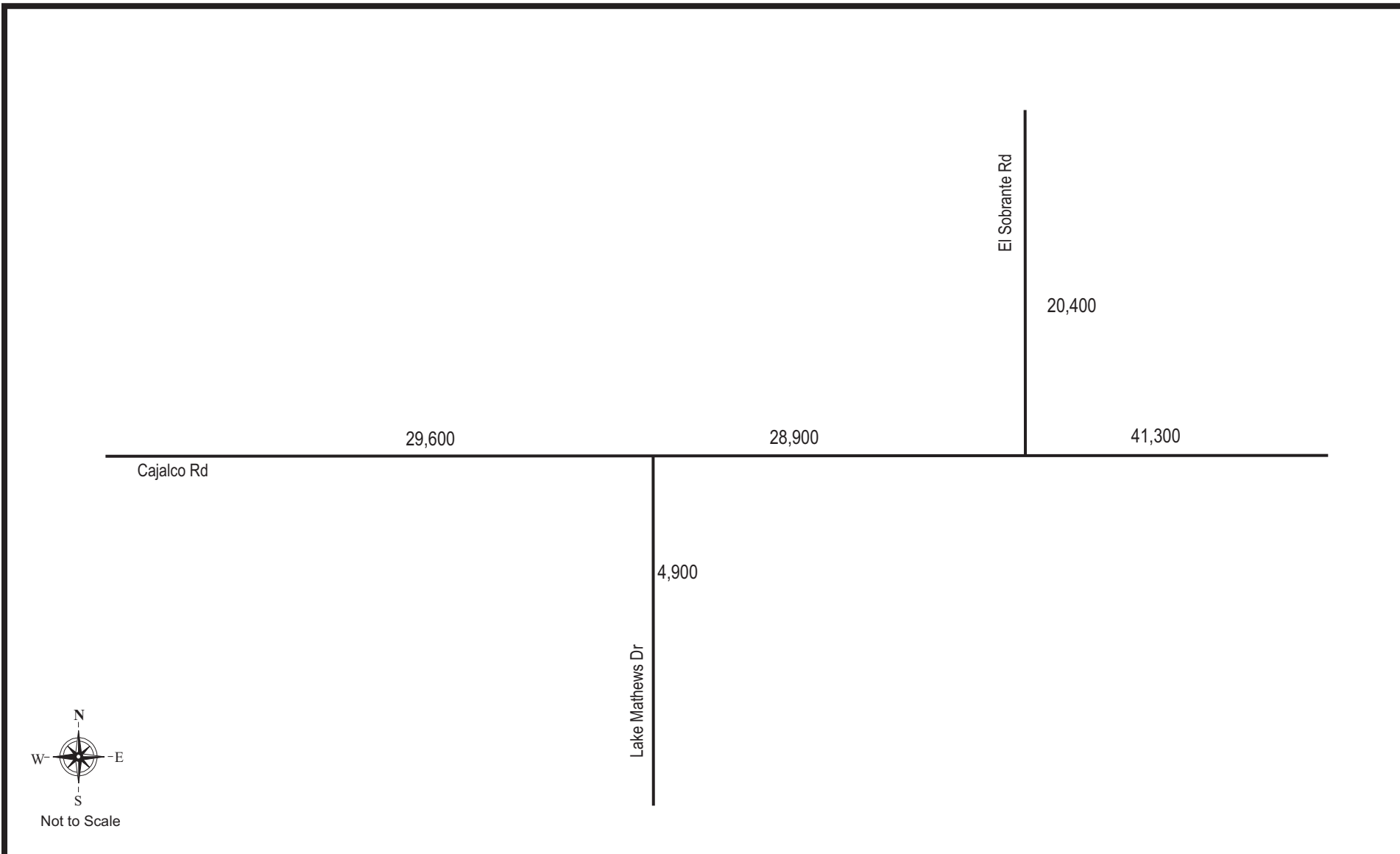

Future Year (2030) ADT - Freeway and Street Segments MCP Area - Alternative 5 Modified

Figure 9-10c

Legend:

XX,XXX Average Daily Traffic



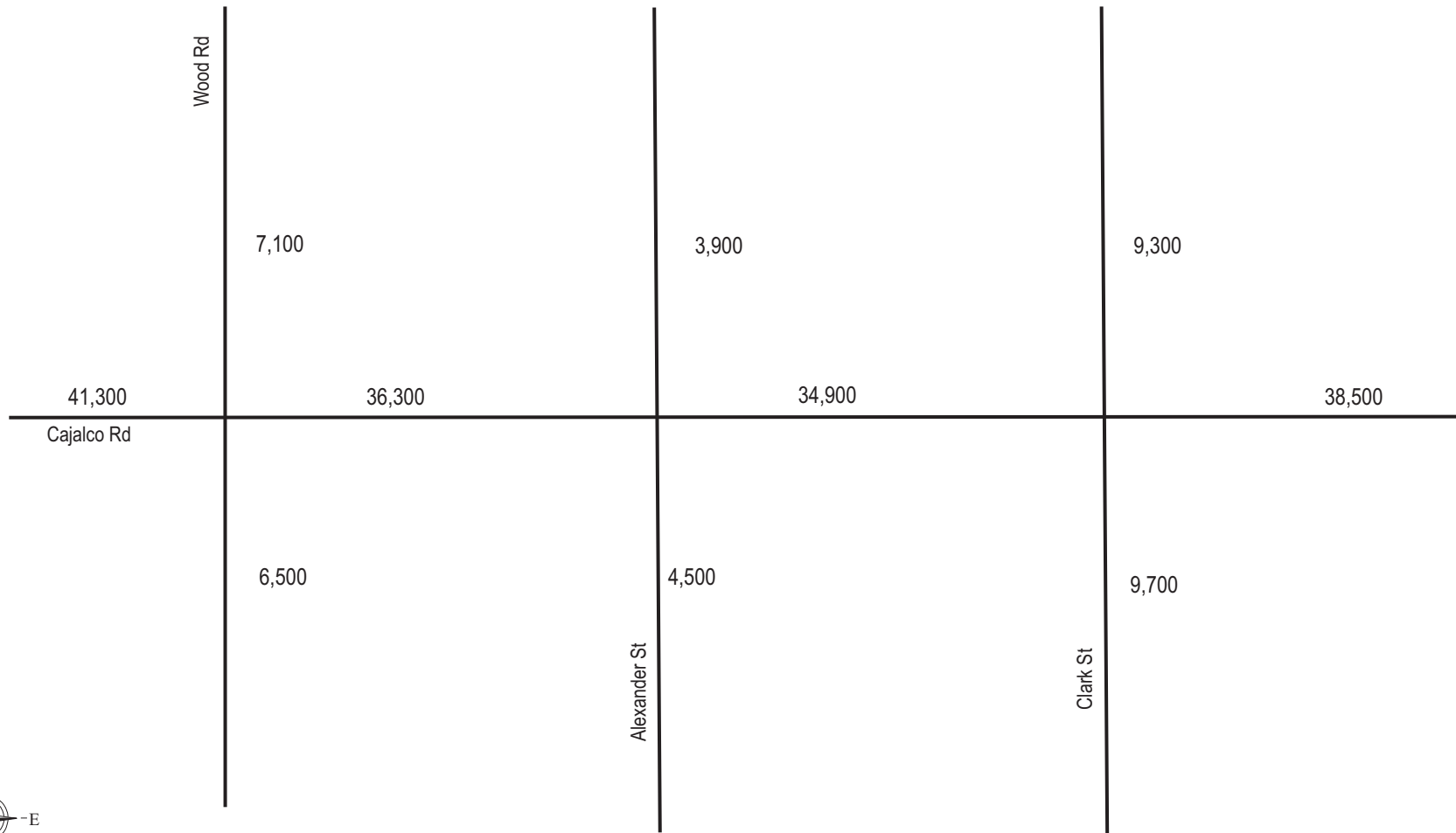

Future Year (2030) ADT - Freeway and Street Segments MCP Area - Alternative 5 Modified

Figure 9-10d

Legend:

XX,XXX Average Daily Traffic



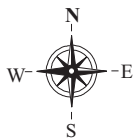
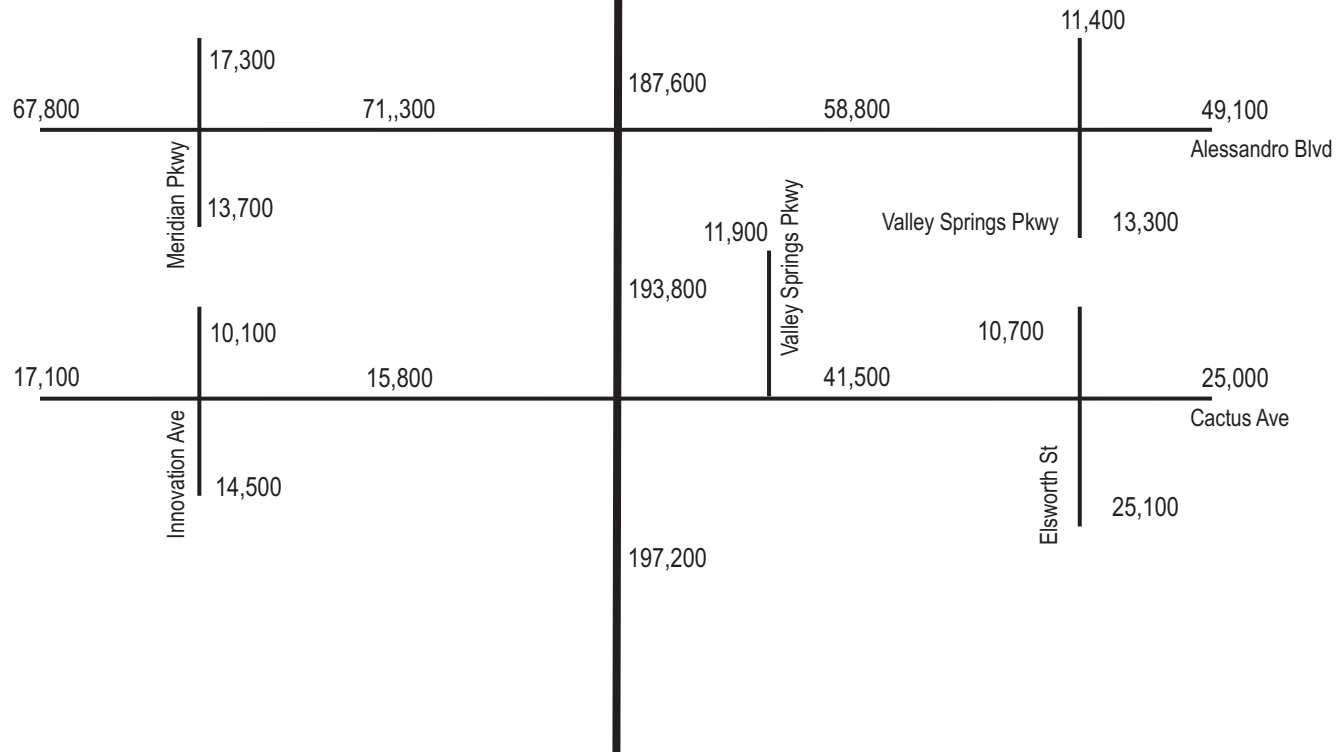

Not to Scale

Future Year (2030) ADT - Freeway and Street Segments MCP Area - Alternative 5 Modified

Figure 9-10e

Legend:

XX,XXX Average Daily Traffic





Not to Scale

Future Year (2030) ADT - Freeway and Street Segments MCP Area - Alternative 5 Modified

Figure 9-10f

Legend:

XX,XXX Average Daily Traffic



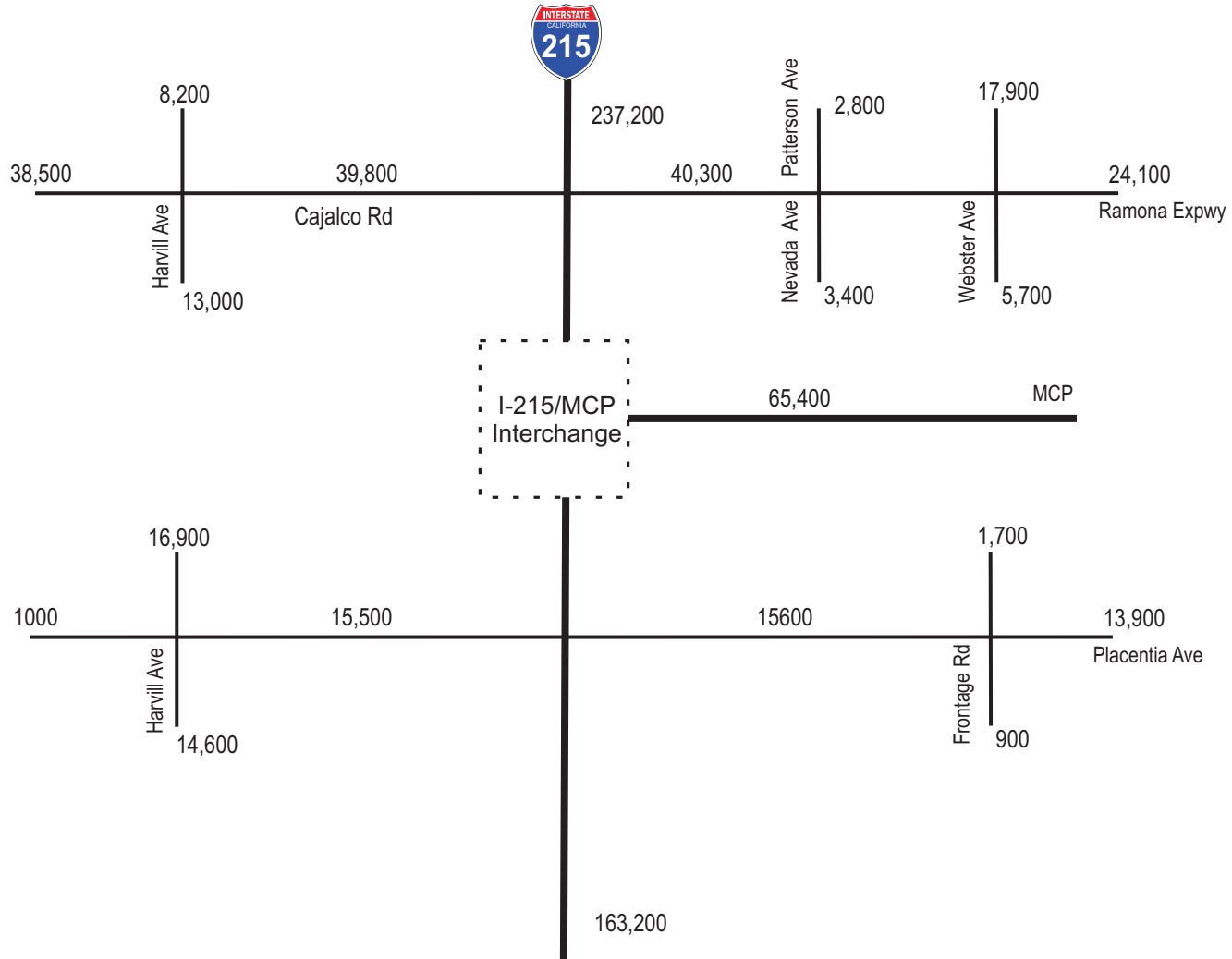

Future Year (2030) ADT - Freeway and Street Segments MCP Area - Alternative 5 Modified

Figure 9-10g

Legend:

XX,XXX Average Daily Traffic





Not to Scale

Future Year (2030) ADT - Freeway and Street Segments MCP Area - Alternative 5 Modified

Figure 9-10h

Legend:

XX,XXX Average Daily Traffic



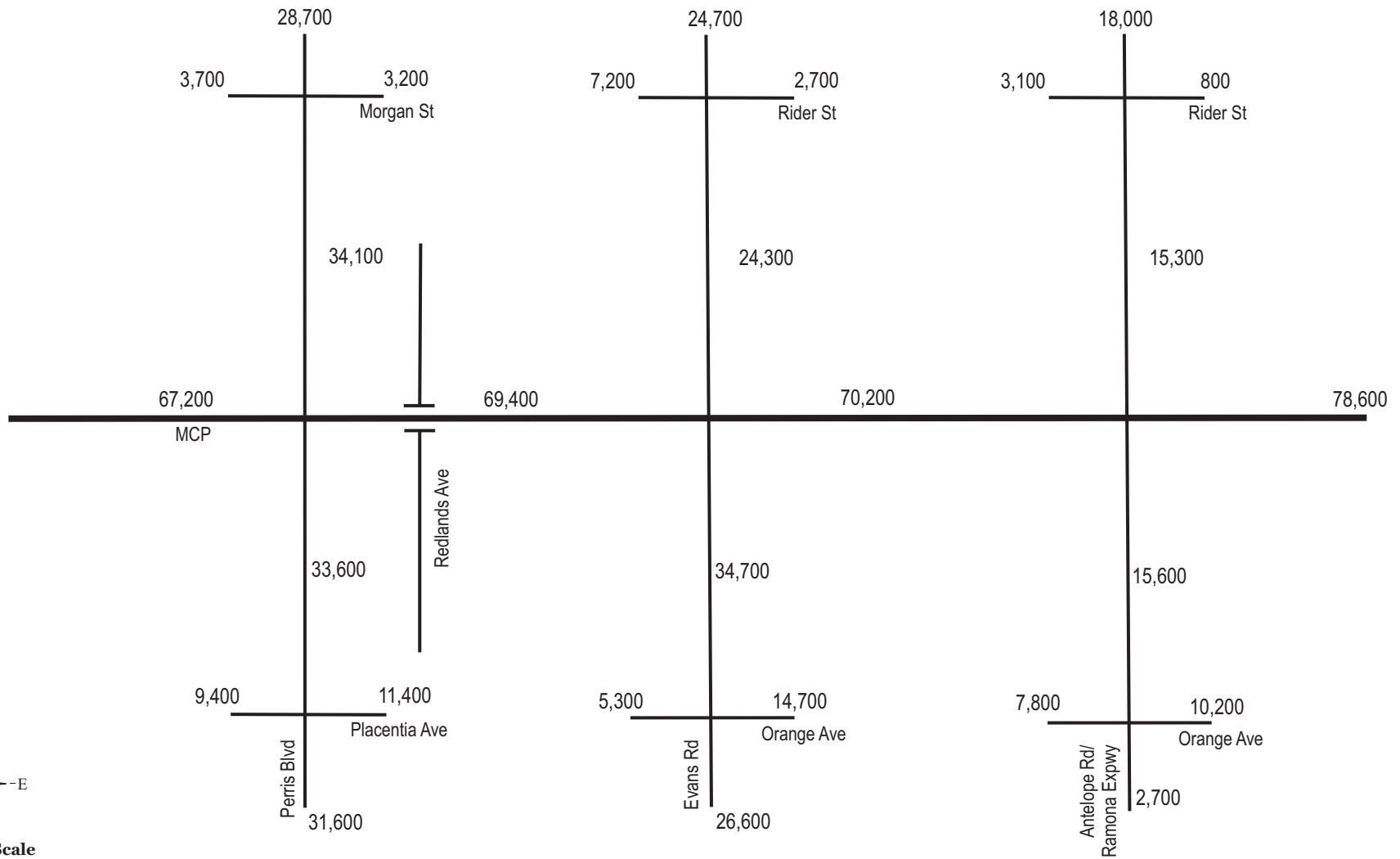

Future Year (2030) ADT - Freeway and Street Segments MCP Area - Alternative 5 Modified

Figure 9-10i

Legend:

XX,XXX Average Daily Traffic



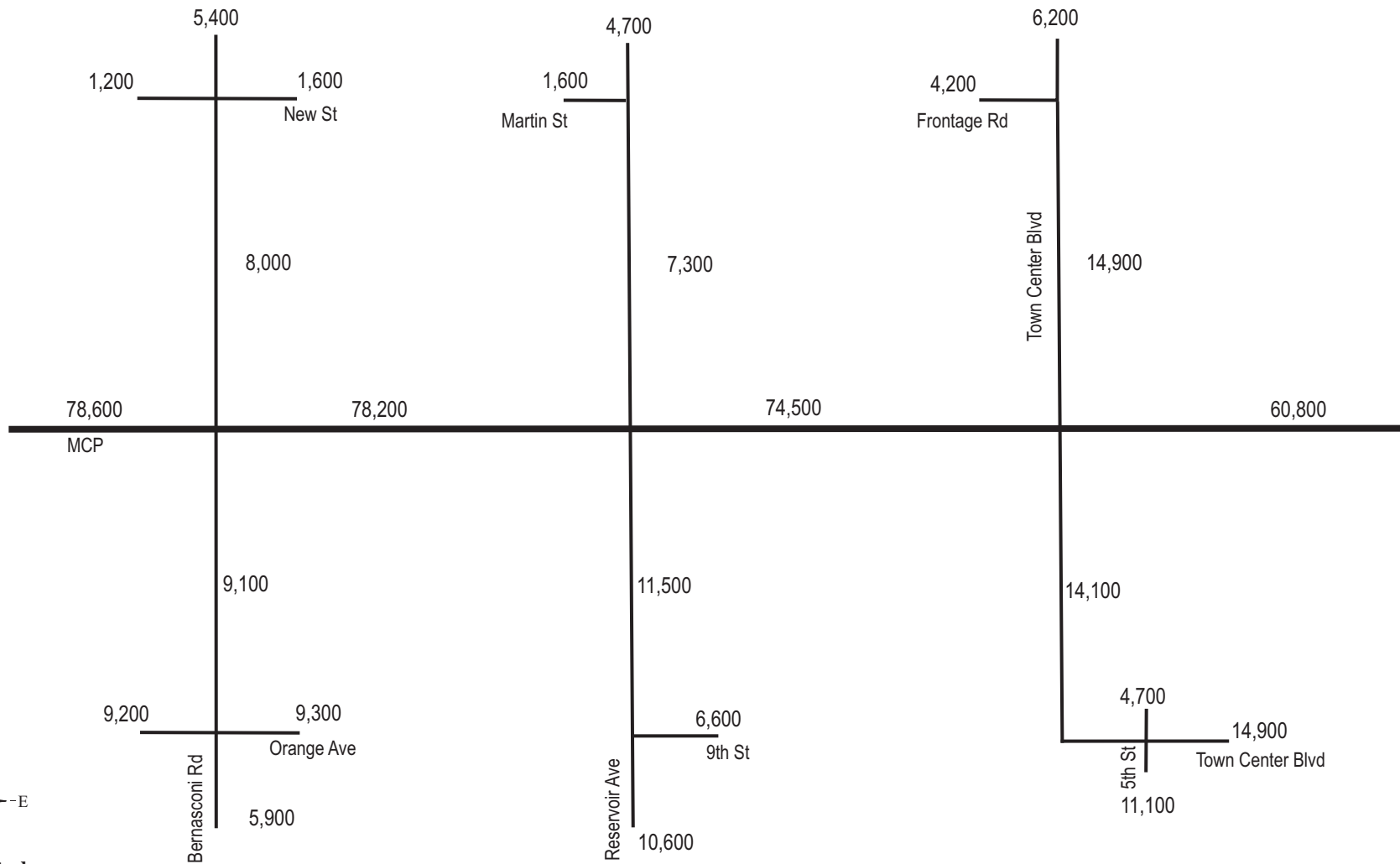

Future Year (2030) ADT - Freeway and Street Segments MCP Area - Alternative 5 Modified

Figure 9-10j

Legend:

XX,XXX Average Daily Traffic



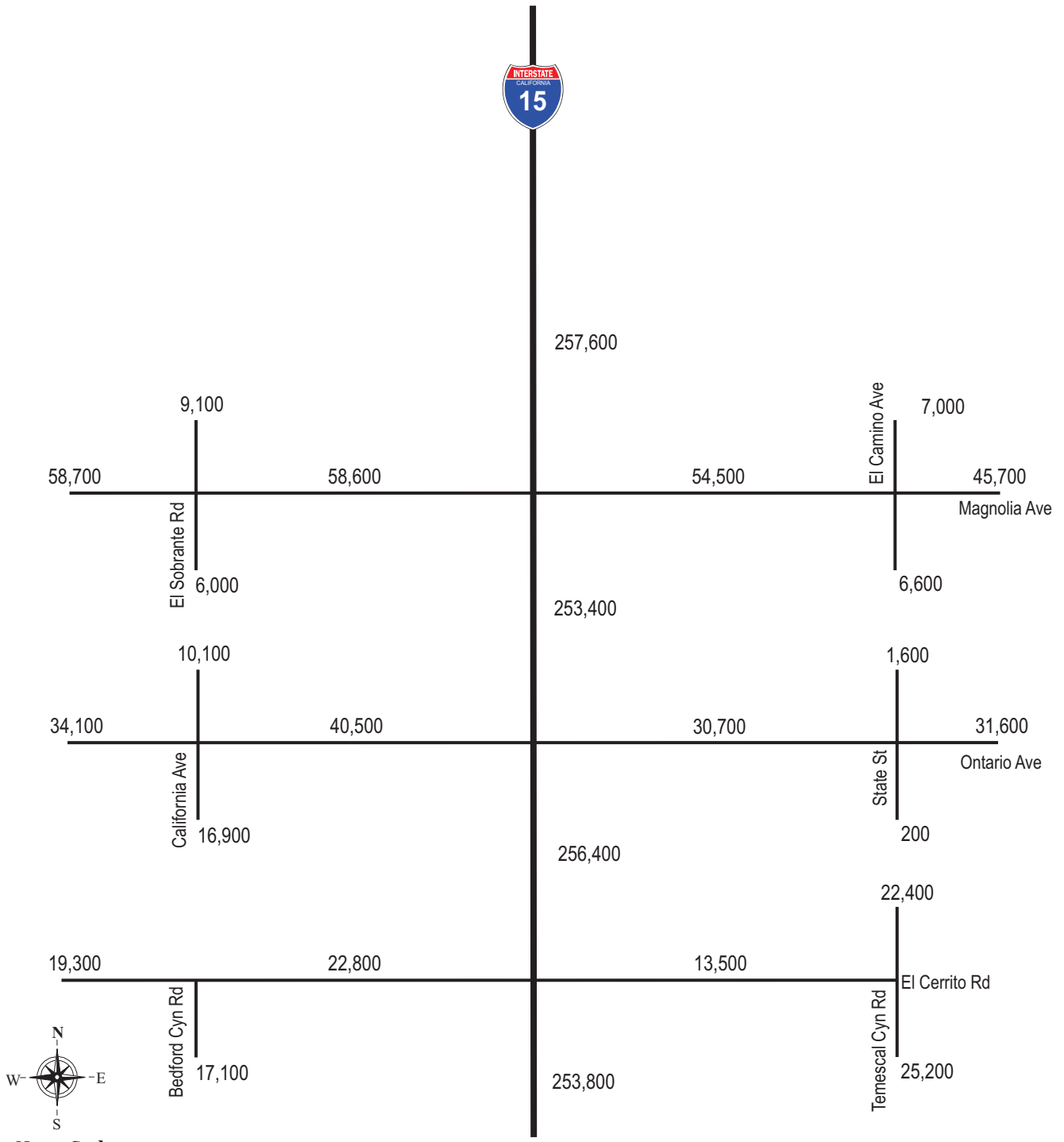

Not to Scale

Future Year (2030) ADT - Freeway and Street Segments MCP Area - Alternative 9 Modified

Figure 9-11a

Legend:

XX,XXX Average Daily Traffic



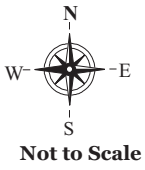
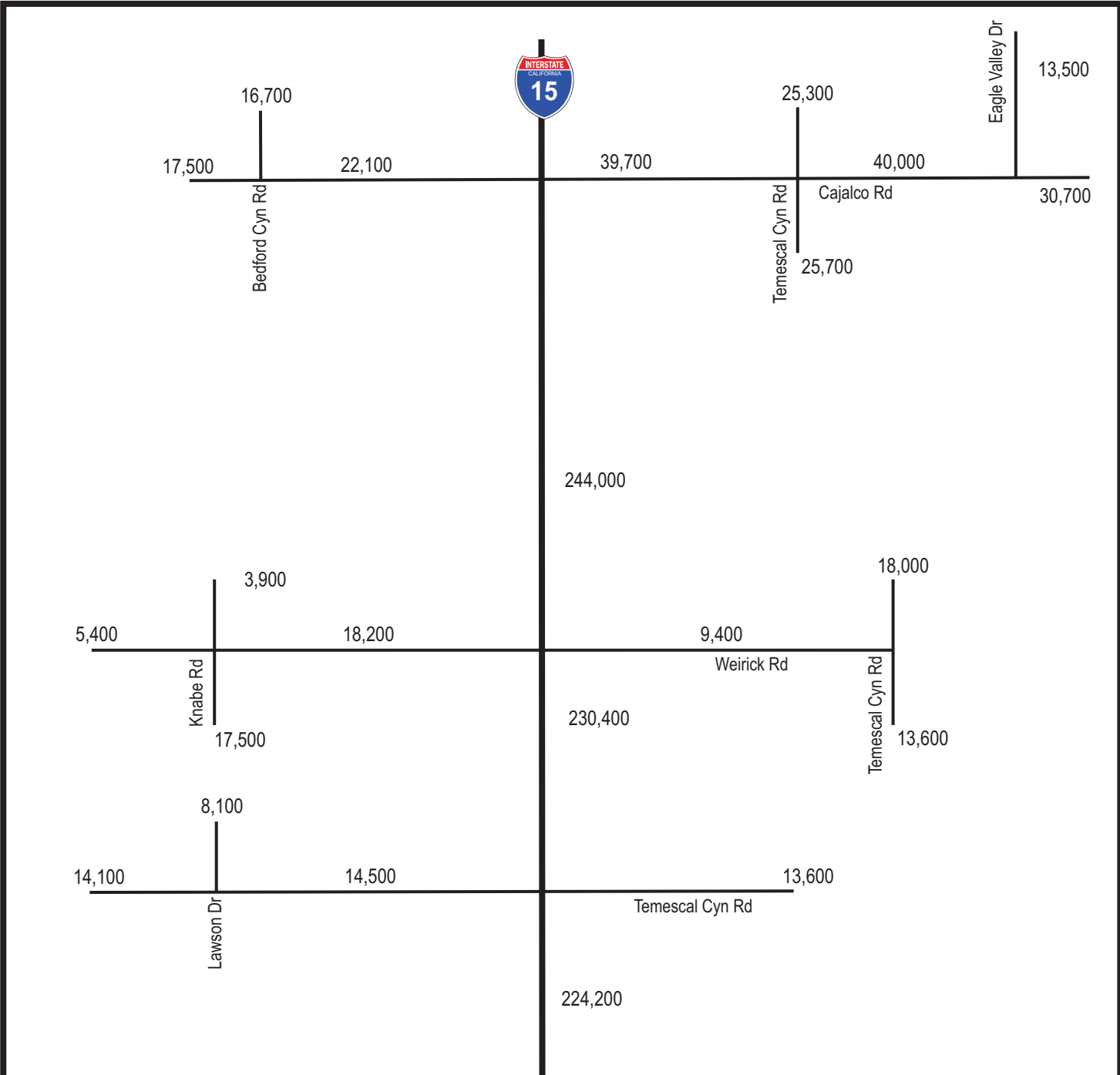

Future Year (2030) ADT - Freeway and Street Segments MCP Area - Alternative 9 Modified

Figure 9-11b

Legend:

XX,XXX Average Daily Traffic



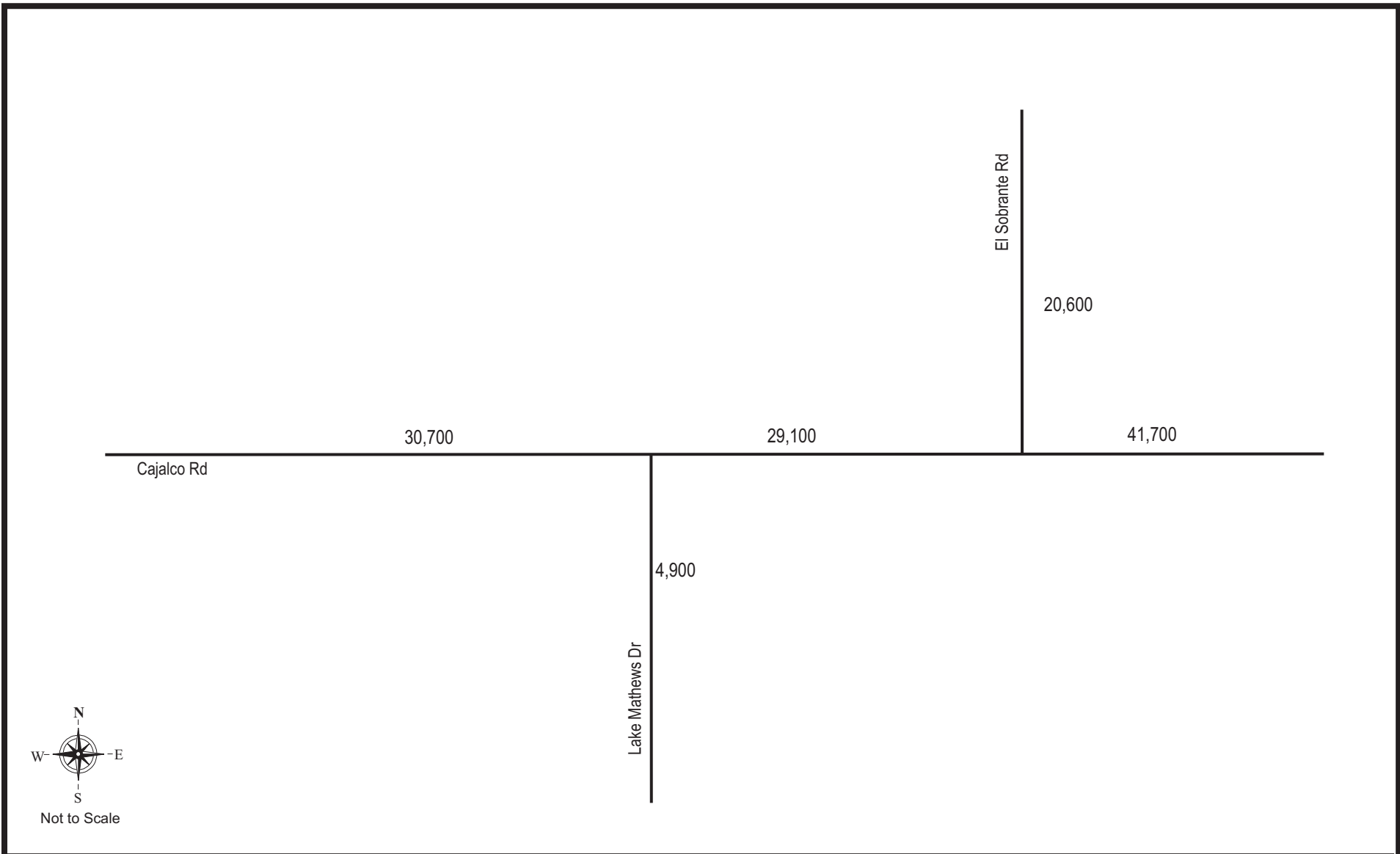

Future Year (2030) ADT - Freeway and Street Segments MCP Area - Alternative 9 Modified

Figure 9-11c

Legend:

XX,XXX Average Daily Traffic



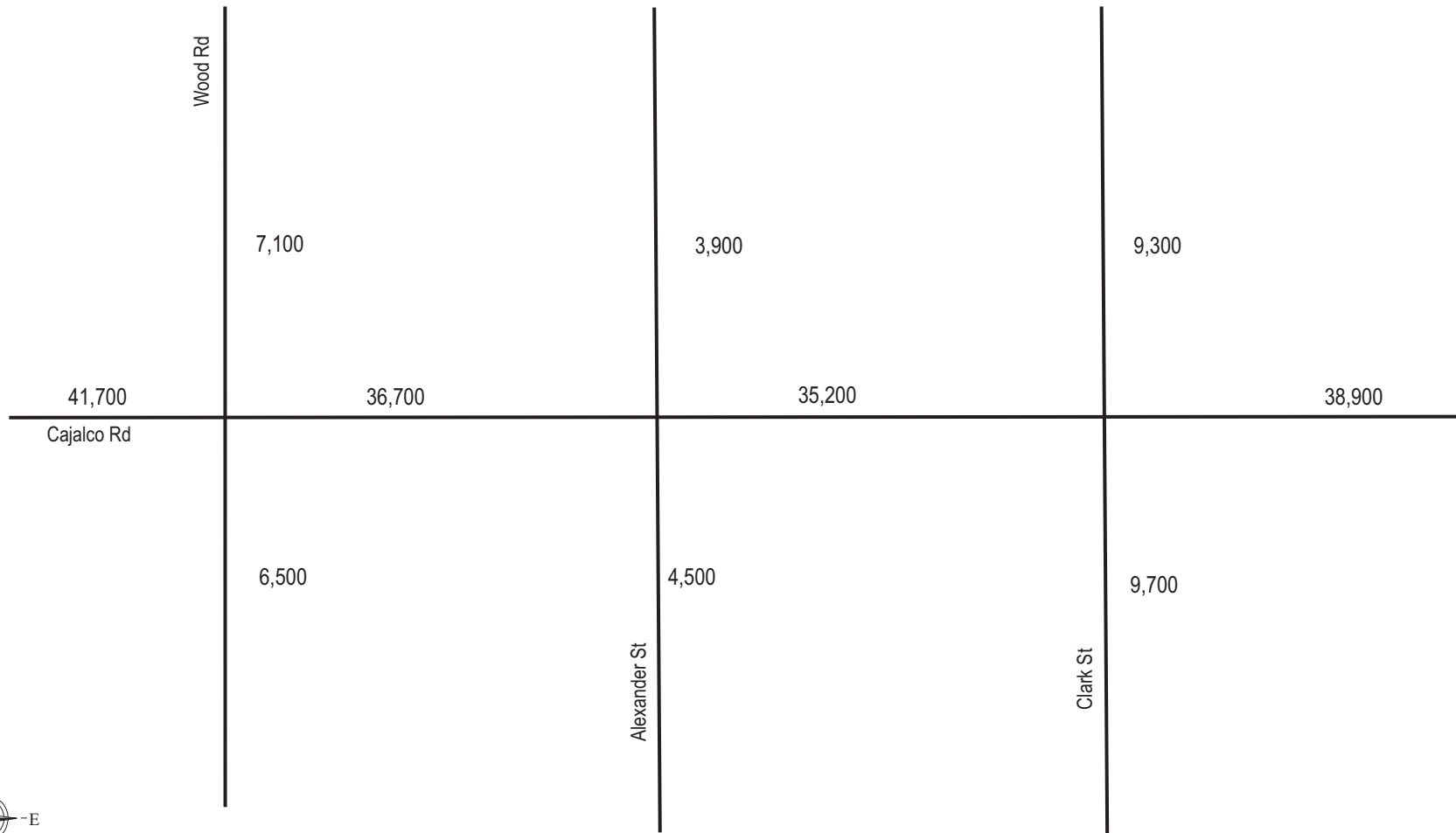

Future Year (2030) ADT - Freeway and Street Segments MCP Area - Alternative 9 Modified

Figure 9-11d

Legend:

XX,XXX Average Daily Traffic



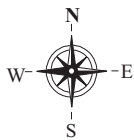
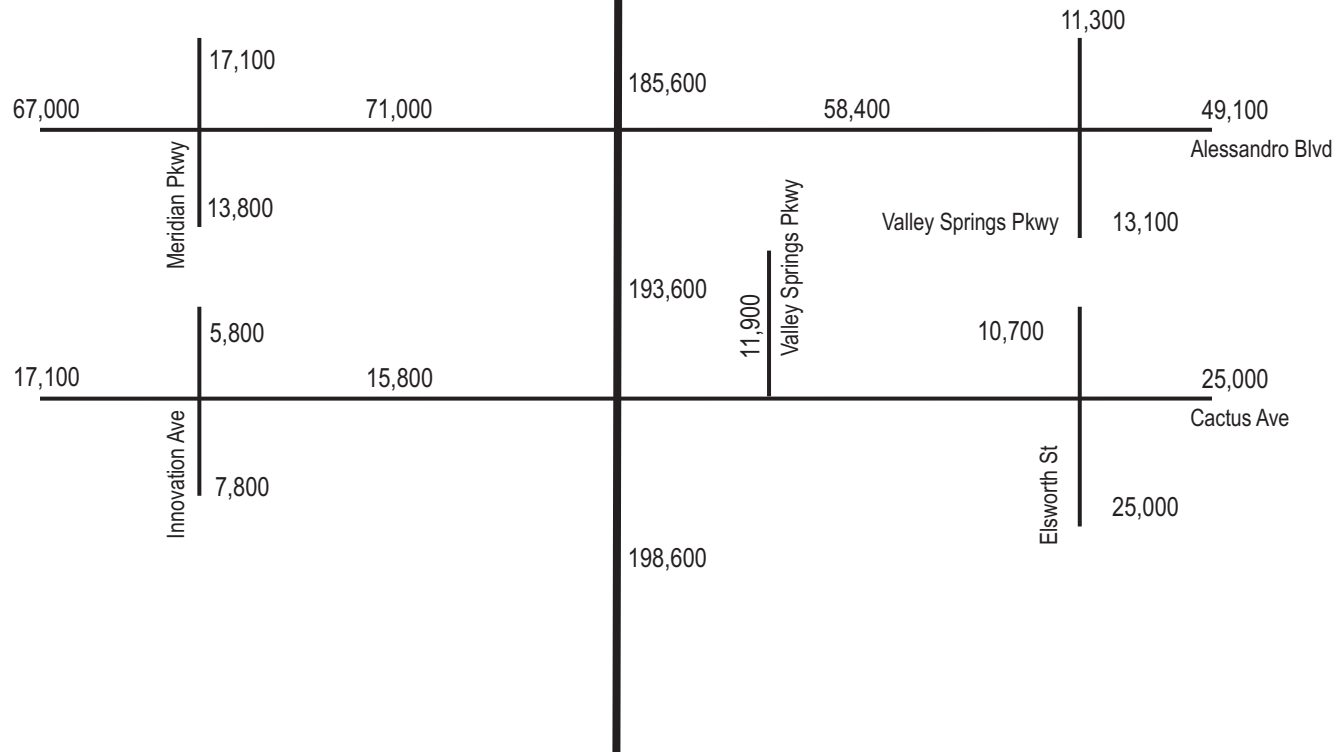

Not to Scale

Future Year (2030) ADT - Freeway and Street Segments MCP Area - Alternative 9 Modified

Figure 9-11e

Legend:

XX,XXX Average Daily Traffic





Not to Scale

Future Year (2030) ADT - Freeway and Street Segments MCP Area - Alternative 9 Modified

Figure 9-11f

Legend:

XX,XXX Average Daily Traffic



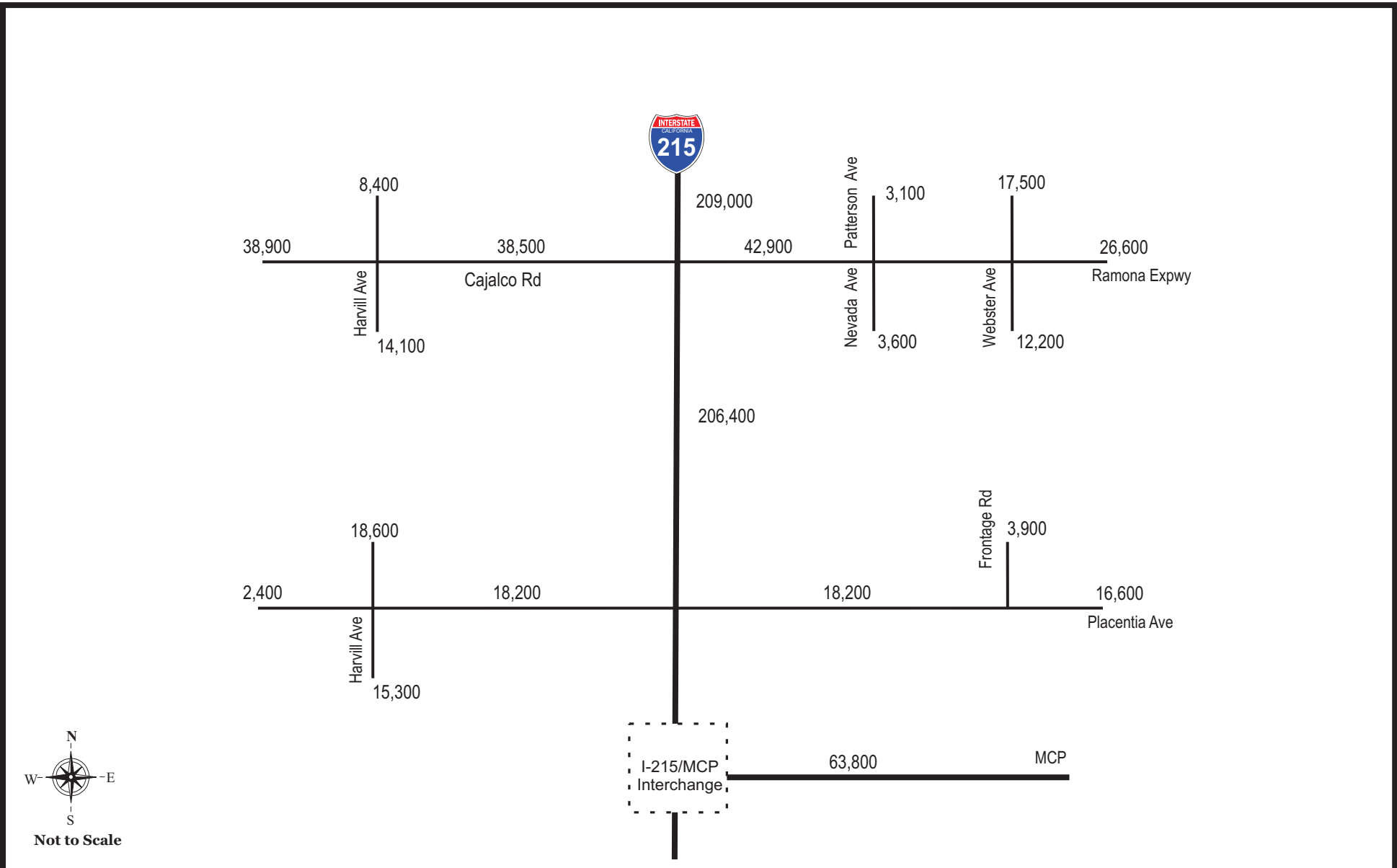

Future Year (2030) ADT - Freeway and Street Segments MCP Area - Alternative 9 Modified

Figure 9-11g

Legend:

XX,XXX Average Daily Traffic



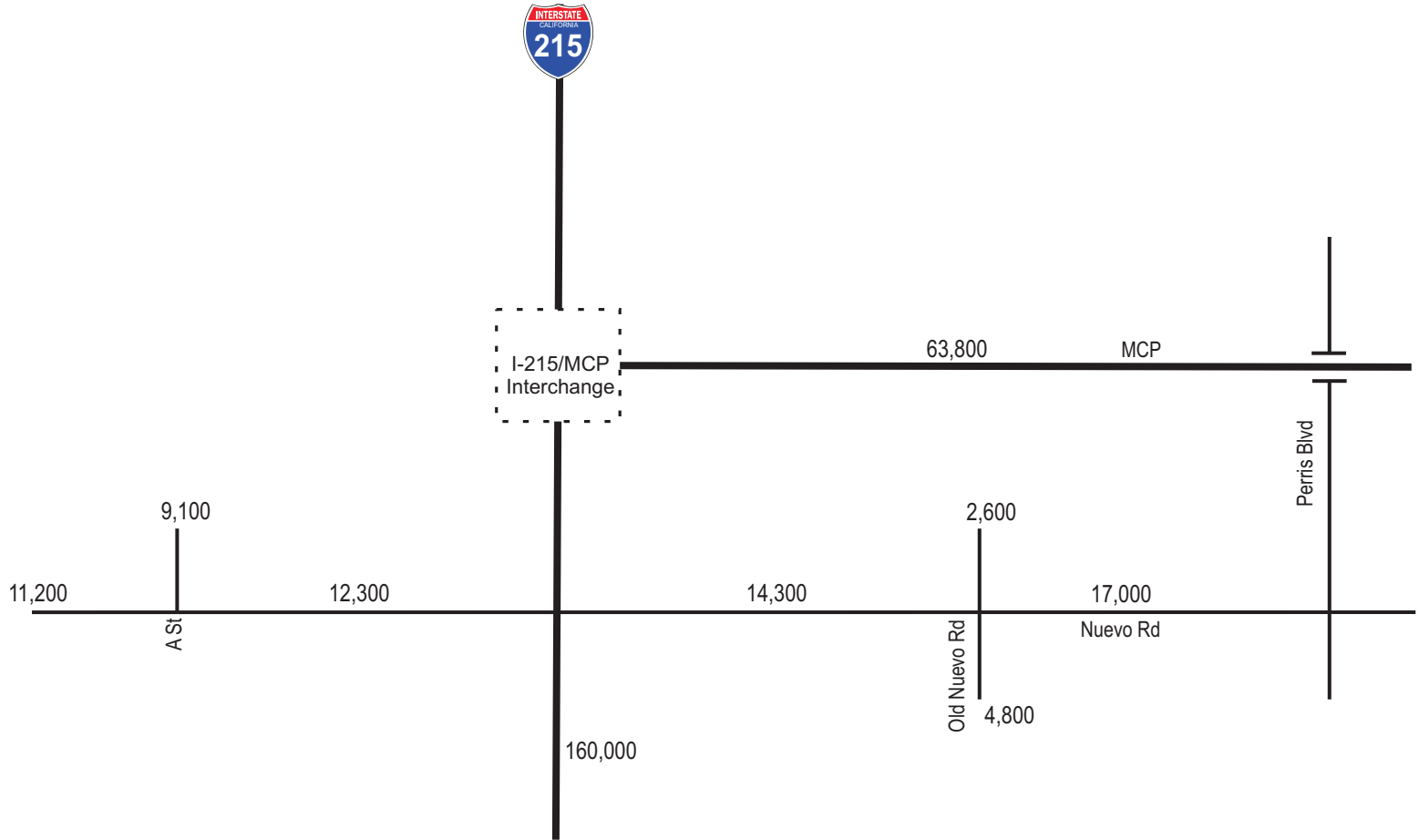

Not to Scale

Future Year (2030) ADT - Freeway and Street Segments MCP Area - Alternative 9 Modified

Figure 9-11h

Legend:

XX,XXX Average Daily Traffic



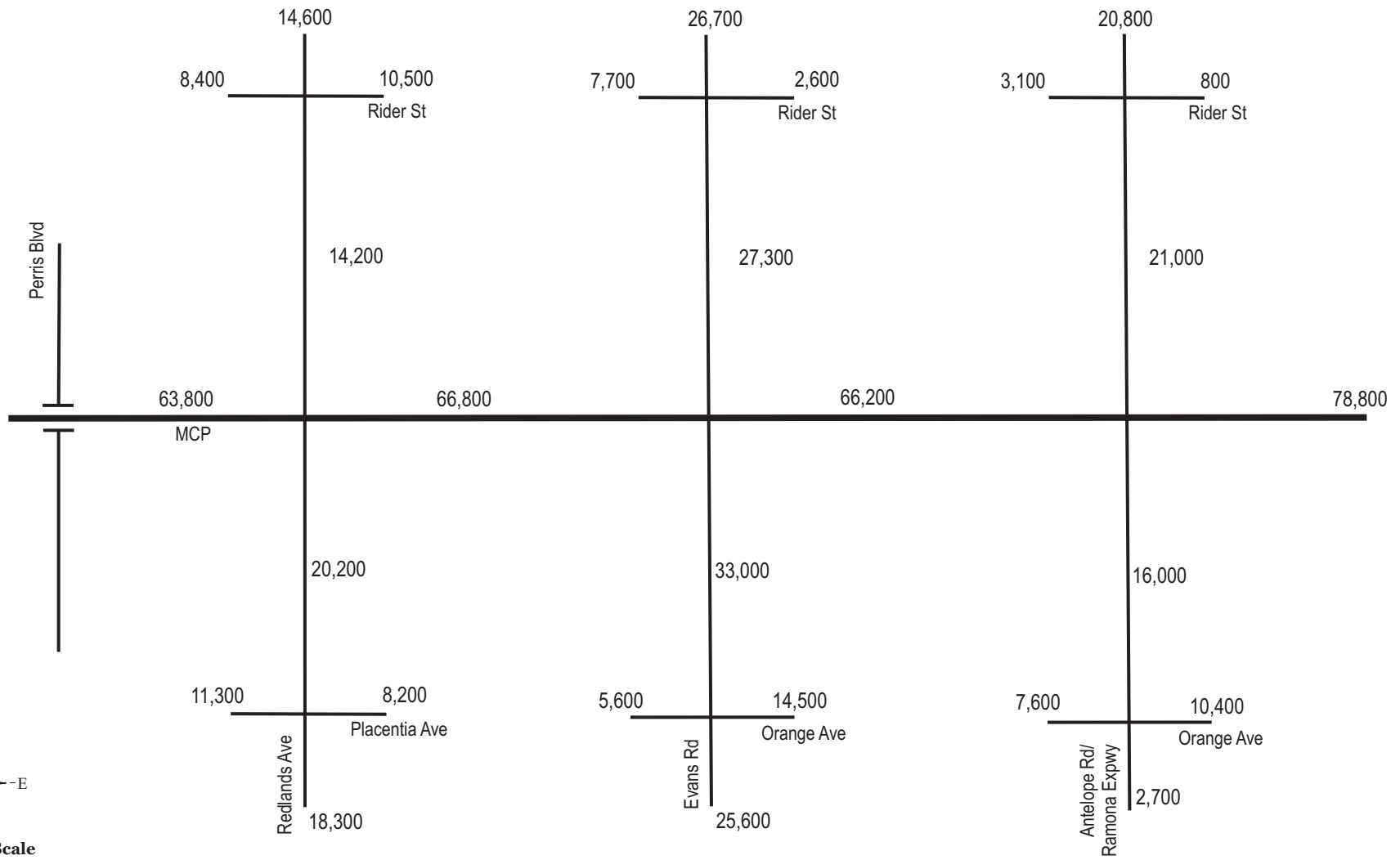

Future Year (2030) ADT - Freeway and Street Segments MCP Area - Alternative 9 Modified

Figure 9-11i

Legend:

XX,XXX Average Daily Traffic



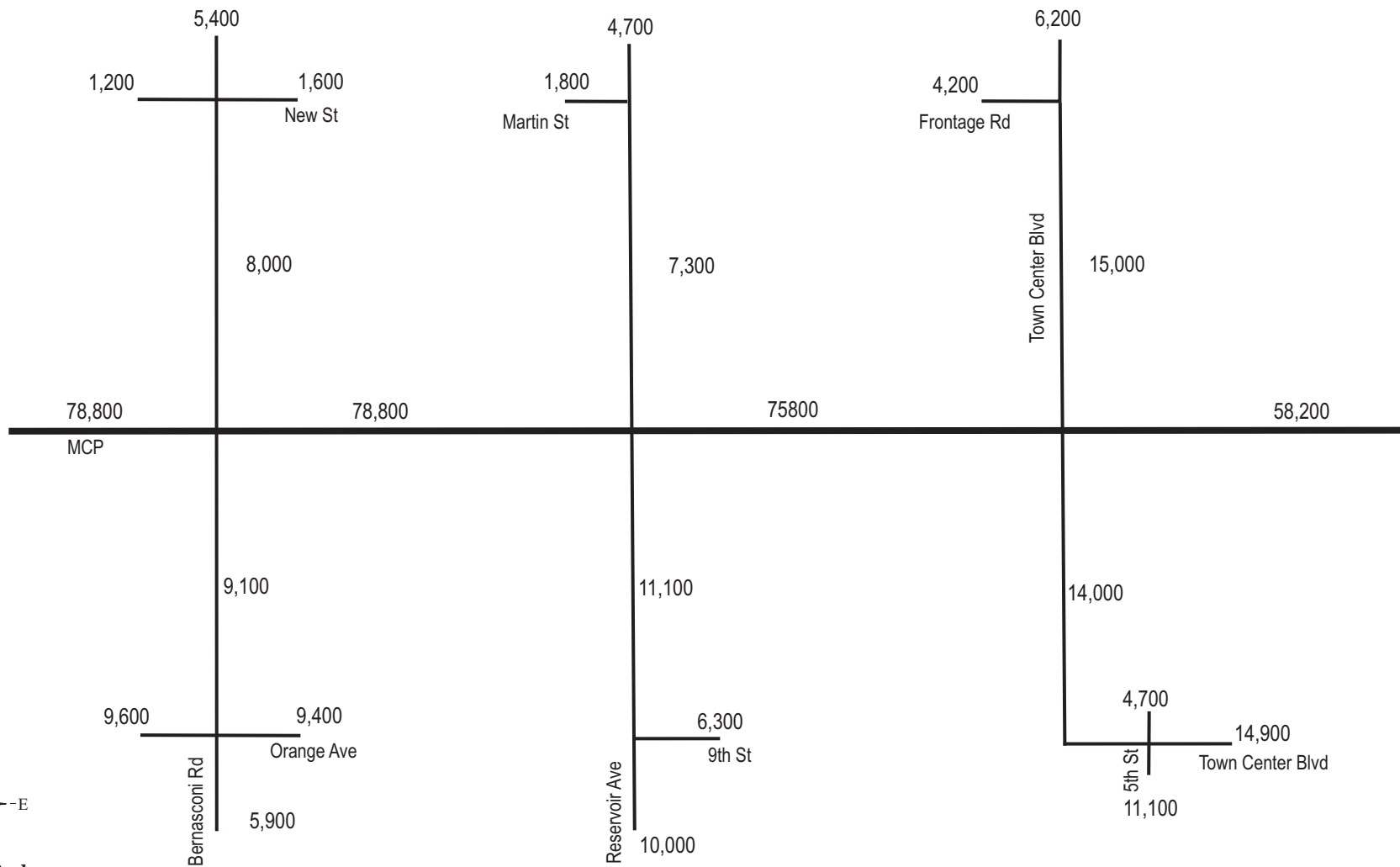

Future Year (2030) ADT - Freeway and Street Segments MCP Area - Alternative 9 Modified

Figure 9-11j

Legend:

XX,XXX Average Daily Traffic



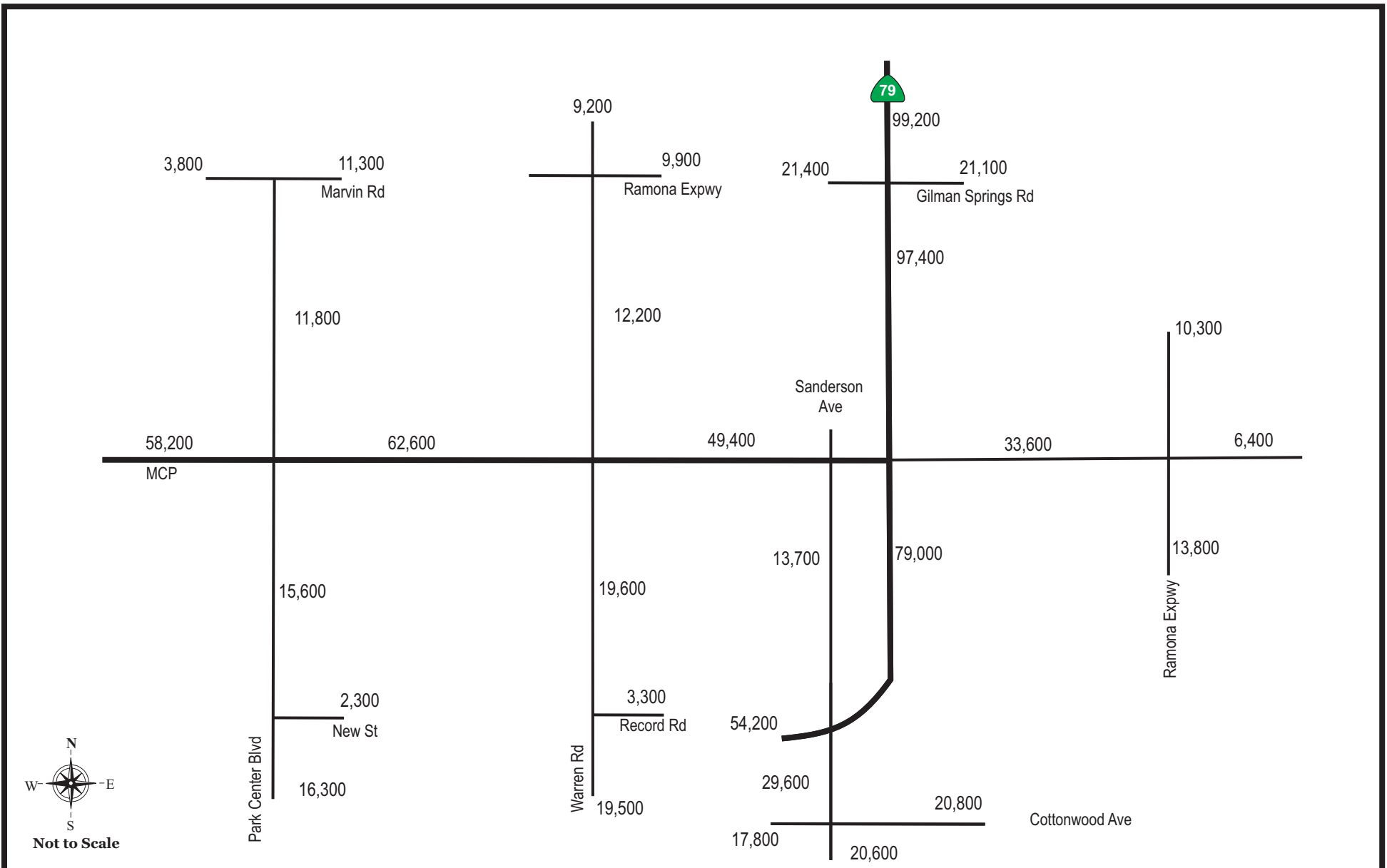

Future Year (2030) ADT - Freeway and Street Segments MCP Area - Alternative 9 Modified

Figure 9-11k

Legend:

XX,XXX Average Daily Traffic



TABLE 9-1
2030 ADT - NO BUILD
ROADWAY SEGMENT CAPACITY ANALYSIS

ROUTE	LIMITS	CLASSIFICATION	TYPICAL MAX ADT (1)	2030 ADT	V/C	LOS
Cajalco Rd	West of Bedford Cyn Rd	4 Lane Arterial	35,900	17,500	0.49	C
	Bedford Cyn Rd to I-15	4 Lane Arterial	35,900	22,100	0.62	C
	I-15 to Temescal Cyn Rd	4 Lane Arterial	53,900	38,700	0.72	C
	Temescal Cyn Rd to Eagle Valley Dr	4 Lane Arterial	35,900	39,000	1.09	F
	Eagle Valley Dr to Lake Mathews Dr	4 Lane Arterial	35,900	29,700	0.83	D
	Lake Mathews Dr to El Sobrante Rd	4 Lane Arterial	35,900	28,100	0.78	C
	El Sobrante Rd to Wood Rd	4 Lane Arterial	53,900	40,200	0.75	C
	Wood Rd to Alexander St	4 Lane Arterial	35,900	35,200	0.98	E
	Alexander St to Clark St	4 Lane Arterial	35,900	33,700	0.94	E
	Clark St to Harvill Ave	4 Lane Arterial	35,900	37,400	1.04	F
Harvill Ave to I-215	4 Lane Arterial	35,900	37,000	1.03	F	
Magnolia Ave	West of El Sobrante Rd	6 Lane Urban Arterial	53,900	58,700	1.09	F
	El Sobrante Rd to I-15	6 Lane Urban Arterial	53,900	58,600	1.09	F
	I-15 to El Camino Ave	4 Lane Arterial	35,900	54,500	1.52	F
	East of El Camino Ave	4 Lane Arterial	53,900	45,700	0.85	D
Ontario Ave	West of California Ave	6 Lane Urban Arterial	53,900	34,100	0.63	C
	California Ave to I-15	4 Lane Arterial	35,900	40,500	1.13	F
	I-15 to State St	4 Lane Arterial	35,900	30,700	0.86	D
	East of State St	6 Lane Urban Arterial	53,900	31,600	0.59	C
El Cerrito Rd	West of Bedford Cyn Rd	4 Lane Arterial	35,900	19,300	0.54	C
	Bedford Cyn Rd to I-15	4 Lane Arterial	35,900	22,800	0.64	C
	I-15 to Temescal Cyn Rd	4 Lane Arterial	35,900	13,500	0.38	C
Weirick Rd	West of Knabe Rd	2 Lane Collector	13,000	5,400	0.42	C
	Knabe Rd to I-15	4 Lane Arterial	35,900	18,200	0.51	C
	I-15 to Temescal Cyn Rd	4 Lane Arterial	35,900	9,400	0.26	C
Temescal Cyn Rd	West of Lawson Dr	4 Lane Arterial	35,900	14,100	0.39	C
	Lawson Dr to I-15	4 Lane Arterial	35,900	14,500	0.40	C
	I-15 to Weirick Rd	4 Lane Arterial	35,900	13,600	0.38	C
Eagle Valley Dr	North of Cajalco Rd	4 Lane Arterial	35,900	13,500	0.38	C
El Sobrante Rd	North of Cajalco Rd	4 Lane Arterial	35,900	20,100	0.56	C
Wood Rd	North of Cajalco Rd	4 Lane Arterial	35,900	7,100	0.20	C
	South of Cajalco Rd	4 Lane Arterial	35,900	6,500	0.18	C
Alexander St	North of Cajalco Rd	4 Lane Arterial	35,900	3,900	0.11	C
	South of Cajalco Rd	4 Lane Arterial	35,900	4,500	0.13	C
Clark St	North of Cajalco Rd	4 Lane Arterial	35,900	9,300	0.26	C
	South of Cajalco Rd	4 Lane Arterial	35,900	9,700	0.27	C

(1) Maximum capacity at level of service E
ADT = Average Daily Traffic
V/C = Volume to Capacity Ratio
LOS = Level of Service

TABLE 9-1 (continued)
2030 ADT - NO BUILD
ROADWAY SEGMENT CAPACITY ANALYSIS

ROUTE	LIMITS	CLASSIFICATION	TYPICAL MAX ADT (1)	2030 ADT	V/C	LOS
Alessandro Blvd	West of Meridian Pkwy	6 Lane Urban Arterial	53,900	67,000	1.24	F
	Meridian Pkwy to I-215	6 Lane Urban Arterial	53,900	70,500	1.31	F
	I-215 to Valley Springs Pkwy	6 Lane Urban Arterial	53,900	58,400	1.08	F
	East of Valley Springs Pkwy	6 Lane Urban Arterial	53,900	49,100	0.91	E
Cactus Ave	West of Innovation Dr	4 Lane Arterial	35,900	17,100	0.48	C
	Innovation Dr to I-215	6 Lane Urban Arterial	53,900	15,800	0.29	C
	I-215 to Elsworth St	6 Lane Urban Arterial	53,900	41,800	0.78	C
	East of Elsworth St	6 Lane Urban Arterial	53,900	25,000	0.46	C
Van Buren Blvd	West of Meridian Pkwy	6 Lane Urban Arterial	53,900	50,000	0.93	E
	Meridian Pkwy to I-215	6 Lane Urban Arterial	53,900	44,200	0.82	D
	East of I-215	4 Lane Arterial	35,900	8,800	0.25	C
Harley Knox Blvd	West of Harvill Ave	6 Lane Urban Arterial	53,900	21,200	0.39	C
	Harvill to I-215	6 Lane Urban Arterial	53,900	20,700	0.38	C
	I-215 to Western Way	6 Lane Urban Arterial	53,900	17,700	0.33	C
	East of Western Way	6 Lane Urban Arterial	53,900	22,400	0.42	C
Ramona Expwy	I-215 to Perris Blvd	6 Lane Urban Arterial	53,900	44,800	0.83	D
	Perris Blvd to Evans Rd	6 Lane Urban Arterial	53,900	44,800	0.83	D
	Evans Rd to Bernasconi Rd	6 Lane Urban Arterial	53,900	46,400	0.86	D
	Bernasconi Rd to Reservoir Ave	6 Lane Urban Arterial	53,900	48,000	0.89	D
	Reservoir Ave to Town Center Blvd	6 Lane Urban Arterial	53,900	49,400	0.92	E
	Town Center Blvd to Park Center Blvd	6 Lane Urban Arterial	53,900	35,600	0.66	C
	Park Center Blvd to Warren Rd	6 Lane Urban Arterial	53,900	40,200	0.75	C
	Warren Rd to SR-79	6 Lane Urban Arterial	53,900	28,800	0.53	C
East of SR-79	6 Lane Urban Arterial	53,900	47,400	0.88	D	
Placentia Ave	West of Harvill Ave	4 Lane Arterial	35,900	2,500	0.07	C
	Harvill Ave to I-215	4 Lane Arterial	35,900	17,900	0.50	C
	I-215 to East Frontage Rd	4 Lane Arterial	35,900	17,900	0.50	C
	East of East Frontage Rd	4 Lane Arterial	35,900	10,500	0.29	C
Nuevo Rd	West of A St	4 Lane Arterial	35,900	10,400	0.29	C
	A St to I-215	6 Lane Urban Arterial	53,900	11,500	0.21	C
	I-215 to Old Nuevo	6 Lane Urban Arterial	53,900	17,700	0.33	C
	East of Old Nuevo	6 Lane Urban Arterial	53,900	20,300	0.38	C
Perris Blvd	North of Markham St	6 Lane Urban Arterial	53,900	32,600	0.60	C
	Marham St to Ramona Expwy	6 Lane Urban Arterial	53,900	32,800	0.61	C
	Ramona Expwy to Morgan St	6 Lane Urban Arterial	53,900	29,000	0.54	C
	South of Morgan St	6 Lane Urban Arterial	53,900	30,600	0.57	C
Evans Rd	North of Marbella Gate	6 Lane Urban Arterial	53,900	26,100	0.48	C
	Marbella Gate to Ramona Expwy	6 Lane Urban Arterial	53,900	28,200	0.52	C
	Ramona Expwy to Morgan St	6 Lane Urban Arterial	53,900	29,400	0.55	C
	South of Morgan St	6 Lane Urban Arterial	53,900	33,100	0.61	C

(1) Maximum capacity at level of service E

ADT = Average Daily Traffic

V/C = Volume to Capacity Ratio

LOS = Level of Service

TABLE 9-1 (continued)
2030 ADT - NO BUILD
ROADWAY SEGMENT CAPACITY ANALYSIS

ROUTE	LIMITS	CLASSIFICATION	TYPICAL MAX ADT (1)	2030 ADT	V/C	LOS
Bernasconi Pkwy	North of New St	4 Lane Arterial	35,900	5,400	0.15	C
	New St to Ramona Expwy	4 Lane Arterial	35,900	7,400	0.21	C
	Ramona Expwy to Orange Ave	4 Lane Arterial	35,900	9,100	0.25	C
	South of Orange Ave	4 Lane Arterial	35,900	5,900	0.16	C
Reservoir Ave	North of Martin St	2 Lane Collector	13,000	4,700	0.36	C
	Martin St to Ramona Expwy	4 Lane Arterial	35,900	7,300	0.20	C
	Ramona Expwy to 9th St	4 Lane Arterial	35,900	8,500	0.24	C
	South of 9th St	4 Lane Arterial	35,900	10,000	0.28	C
Town Center Blvd	North of Frontage Rd	4 Lane Arterial	35,900	6,200	0.17	C
	Frontage Rd to Ramona Expwy	4 Lane Arterial	35,900	15,900	0.44	C
	Ramona Expwy to 5th St	4 Lane Arterial	35,900	14,000	0.39	C
	South of 5th St	4 Lane Arterial	35,900	16,900	0.47	C
Park Center Blvd	Marvin Rd to Ramona Expwy	4 Lane Arterial	35,900	10,300	0.29	C
	to Lakeview Ave	4 Lane Arterial	35,900	14,900	0.42	C
	South of Lakeview Ave	4 Lane Arterial	35,900	15,500	0.43	C
Warren Rd	North of Ramona Expwy	4 Lane Arterial	35,900	8,100	0.23	C
	Ramona Expwy to Record Rd	4 Lane Arterial	35,900	18,000	0.50	C
	South of Record Rd	4 Lane Arterial	35,900	17,500	0.49	C
Gilman Springs Rd	West of SR-79	4 Lane Arterial	35,900	27,600	0.77	C
	East of SR-79	4 Lane Arterial	35,900	17,800	0.50	C
Lyon Ave	North of Ramona Expwy	4 Lane Arterial	35,900	4,300	0.12	C
	South of Ramona Expwy	4 Lane Arterial	35,900	4,600	0.13	C
Sanderson Ave	North of SR-79	4 Lane Arterial	35,900	15,600	0.43	C
	SR-79 to Cottonwood Ave	4 Lane Arterial	35,900	26,000	0.72	C
	South of Cottonwood Ave	4 Lane Arterial	35,900	20,600	0.57	C
Cottonwood Ave	West of Sanderson Ave	4 Lane Arterial	35,900	20,700	0.58	C
	East of Sanderson Ave	4 Lane Arterial	35,900	20,200	0.56	C

(1) Maximum capacity at level of service E

ADT = Average Daily Traffic

V/C = Volume to Capacity Ratio

LOS = Level of Service

TABLE 9-1 (continued)
 2030 ADT - NO BUILD
 FREEWAY SEGMENT CAPACITY ANALYSIS

ROUTE	LIMITS	CLASSIFICATION	TYPICAL MAX ADT (1)	2030 ADT (2)	V/C	LOS
I-15	North of Magnolia Ave	8 Lane Freeway	160,500	182,600	1.14	F
	Magnolia Ave to Ontario Ave	8 Lane Freeway	160,500	178,400	1.11	F
	Ontario Ave to El Cerrito Rd	8 Lane Freeway	160,500	181,400	1.13	F
	El Cerrito Rd to Cajalco Rd	8 Lane Freeway	160,500	178,800	1.11	F
	Cajalco Rd to Weirick Rd	8 Lane Freeway	160,500	170,000	1.06	F
	Weirick Rd to Temescal Cyn Rd	8 Lane Freeway	160,500	156,400	0.97	E
	South of Temescal Cyn Rd	8 Lane Freeway	160,500	150,200	0.94	E
I-215	North of Alessandro Blvd	6 Lane Freeway	117,500	179,600	1.53	F
	Alessandro Blvd to Cactus Ave	6 Lane Freeway	117,500	186,200	1.58	F
	Cactus Ave to Van Buren Blvd	6 Lane Freeway	117,500	190,200	1.62	F
	Van Buren Blvd to Harley Knox Blvd	6 Lane Freeway	117,500	196,000	1.22	F
	Harley Knox Blvd to Ramona Expwy	6 Lane Freeway	117,500	182,800	1.67	E
	Ramona Expwy to Placentia Ave	6 Lane Freeway	117,500	168,600	1.56	F
	Placentia Ave to Nuevo Rd	6 Lane Freeway	117,500	168,600	1.56	F
	South of Nuevo Rd	8 Lane Freeway	160,500	170,000	1.06	F
SR-79	North of Gilman Springs Rd	4 Lane Freeway	76,500	98,100	1.28	F
	Gilman Spring Rd to Ramona Expwy	4 Lane Freeway	76,500	105,000	1.37	F
	Ramona Expwy to Sanderson Ave	4 Lane Freeway	76,500	70,000	0.92	E
	West of Sanderson Ave	4 Lane Freeway	76,500	54,400	0.71	C

(1) Maximum capacity at level of service E
 (2) Express Lanes on I-15 and HOV Lanes on I-215 not included
 ADT = Average Daily Traffic
 V/C = Volume to Capacity Ratio
 LOS = Level of Service

TABLE 9-2
2030 ADT - ALTERNATIVE 4 MODIFIED
ROADWAY SEGMENT CAPACITY ANALYSIS

ROUTE	LIMITS	CLASSIFICATION	TYPICAL MAX ADT (1)	2030 ADT	V/C	LOS
Cajalco Rd	West of Bedford Cyn Rd	4 Lane Arterial	35,900	17,500	0.49	C
	Bedford Cyn Rd to I-15	4 Lane Arterial	35,900	22,100	0.62	C
	I-15 to Temescal Cyn Rd	4 Lane Arterial	53,900	40,000	0.74	C
	Temescal Cyn Rd to Eagle Valley Dr	4 Lane Arterial	35,900	39,800	1.11	F
	Eagle Valley Dr to Lake Mathews Dr	4 Lane Arterial	35,900	29,600	0.82	D
	Lake Mathews Dr to El Sobrante Rd	4 Lane Arterial	35,900	29,000	0.81	D
	El Sobrante Rd to Wood Rd	4 Lane Arterial	53,900	41,500	0.77	C
	Wood Rd to Alexander St	4 Lane Arterial	35,900	36,500	1.02	F
	Alexander St to Clark St	4 Lane Arterial	35,900	35,100	0.98	E
	Clark St to Harvill Ave	4 Lane Arterial	35,900	38,700	1.08	F
Harvill Ave to I-215	4 Lane Arterial	35,900	39,900	1.11	F	
Magnolia Ave	West of El Sobrante Rd	6 Lane Urban Arterial	53,900	58,700	1.09	F
	El Sobrante Rd to I-15	6 Lane Urban Arterial	53,900	58,600	1.09	F
	I-15 to El Camino Ave	4 Lane Arterial	35,900	54,500	1.52	F
	East of El Camino Ave	4 Lane Arterial	53,900	45,700	0.85	D
Ontario Ave	West of California Ave	6 Lane Urban Arterial	53,900	35,000	0.65	C
	California Ave to I-15	4 Lane Arterial	35,900	40,500	1.13	F
	I-15 to State St	4 Lane Arterial	35,900	30,700	0.86	D
	East of State St	6 Lane Urban Arterial	53,900	31,600	0.59	C
El Cerrito Rd	West of Bedford Cyn Rd	4 Lane Arterial	35,900	19,300	0.54	C
	Bedford Cyn Rd to I-15	4 Lane Arterial	35,900	23,000	0.64	C
	I-15 to Temescal Cyn Rd	4 Lane Arterial	35,900	13,500	0.38	C
Weirick Rd	West of Knabe Rd	2 Lane Collector	13,000	5,400	0.42	C
	Knabe Rd to I-15	4 Lane Arterial	35,900	18,200	0.51	C
	I-15 to Temescal Cyn Rd	4 Lane Arterial	35,900	9,400	0.26	C
Temescal Cyn Rd	West of Lawson Dr	4 Lane Arterial	35,900	14,100	0.39	C
	Lawson Dr to I-15	4 Lane Arterial	35,900	14,500	0.40	C
	I-15 to Weirick Rd	4 Lane Arterial	35,900	13,600	0.38	C
Eagle Valley Dr	North of Cajalco Rd	4 Lane Arterial	35,900	13,500	0.38	C
El Sobrante Rd	North of Cajalco Rd	4 Lane Arterial	35,900	20,600	0.57	C
Wood Rd	North of Cajalco Rd	4 Lane Arterial	35,900	7,100	0.20	C
	South of Cajalco Rd	4 Lane Arterial	35,900	6,500	0.18	C
Alexander St	North of Cajalco Rd	4 Lane Arterial	35,900	3,900	0.11	C
	South of Cajalco Rd	4 Lane Arterial	35,900	4,500	0.13	C
Clark St	North of Cajalco Rd	4 Lane Arterial	35,900	9,300	0.26	C
	South of Cajalco Rd	4 Lane Arterial	35,900	9,700	0.27	C

(1) Maximum capacity at level of service E
ADT = Average Daily Traffic
V/C = Volume to Capacity Ratio
LOS = Level of Service

TABLE 9-2 (continued)
 2030 ADT - ALTERNATIVE 4 MODIFIED
 ROADWAY SEGMENT CAPACITY ANALYSIS

ROUTE	LIMITS	CLASSIFICATION	TYPICAL MAX ADT (1)	2030 ADT	V/C	LOS
Alessandro Blvd	West of Meridian Pkwy	6 Lane Urban Arterial	53,900	67,700	1.26	F
	Meridian Pkwy to I-215	6 Lane Urban Arterial	53,900	71,300	1.32	F
	I-215 to Valley Springs Pkwy	6 Lane Urban Arterial	53,900	58,800	1.09	F
	East of Valley Springs Pkwy	6 Lane Urban Arterial	53,900	49,000	0.91	E
Cactus Ave	West of Innovation Dr	4 Lane Arterial	35,900	17,100	0.48	C
	Innovation Dr to I-215	6 Lane Urban Arterial	53,900	15,700	0.29	C
	I-215 to Elsworth St	6 Lane Urban Arterial	53,900	41,500	0.77	C
	East of Elsworth St	6 Lane Urban Arterial	53,900	25,000	0.46	C
Van Buren Blvd	West of Meridian Pkwy	6 Lane Urban Arterial	53,900	52,900	0.98	E
	Meridian Pkwy to I-215	6 Lane Urban Arterial	53,900	44,100	0.82	D
	East of I-215	4 Lane Arterial	35,900	11,800	0.33	C
Harley Knox Blvd	West of Harvill Ave	6 Lane Urban Arterial	53,900	21,400	0.40	C
	Harvill to I-215	6 Lane Urban Arterial	53,900	21,900	0.41	C
	I-215 to Western Way	6 Lane Urban Arterial	53,900	13,500	0.25	C
	East of Western Way	6 Lane Urban Arterial	53,900	15,500	0.29	C
Placentia Ave	West of Harvill Ave	4 Lane Arterial	35,900	1,000	0.03	C
	Harvill Ave to I-215	4 Lane Arterial	35,900	15,600	0.43	C
	I-215 to East Frontage Rd	4 Lane Arterial	35,900	15,600	0.43	C
	East of East Frontage Rd	4 Lane Arterial	35,900	14,000	0.39	C
Nuevo Rd	West of A St	4 Lane Arterial	35,900	9,300	0.26	C
	A St to I-215	6 Lane Urban Arterial	53,900	11,700	0.22	C
	I-215 to Old Nuevo	6 Lane Urban Arterial	53,900	13,200	0.24	C
	East of Old Nuevo	6 Lane Urban Arterial	53,900	17,900	0.33	C
Perris Blvd	North of Rider St	6 Lane Urban Arterial	53,900	28,700	0.53	C
	Rider St to MCP	6 Lane Urban Arterial	53,900	34,100	0.63	C
	MCP to Placentia Ave	6 Lane Urban Arterial	53,900	33,600	0.62	C
	South of Placentia Ave	6 Lane Urban Arterial	53,900	35,500	0.66	C
Evans Rd	North of Rider	6 Lane Urban Arterial	53,900	25,700	0.48	C
	Rider to MCP	6 Lane Urban Arterial	53,900	26,200	0.49	C
	MCP to Orange	6 Lane Urban Arterial	53,900	30,900	0.57	C
	South of Orange Ave	6 Lane Urban Arterial	53,900	28,100	0.52	C
Antelope Rd/ Ramona Expressway	North of Rider	4 Lane Arterial	35,900	17,500	0.49	C
	Rider to MCP	4 Lane Arterial	35,900	17,600	0.49	C
	MCP to Orange	4 Lane Arterial	35,900	12,000	0.33	C
	South of Orange Ave	4 Lane Arterial	35,900	2,700	0.08	C

(1) Maximum capacity at level of service E
 ADT = Average Daily Traffic
 V/C = Volume to Capacity Ratio
 LOS = Level of Service

TABLE 9-2 (continued)
2030 ADT - ALTERNATIVE 4 MODIFIED
ROADWAY SEGMENT CAPACITY ANALYSIS

ROUTE	LIMITS	CLASSIFICATION	TYPICAL MAX ADT (1)	2030 ADT	V/C	LOS
Bernasconi Pkwy	North of New St	4 Lane Arterial	35,900	5,400	0.15	C
	New St to MCP	4 Lane Arterial	35,900	8,000	0.22	C
	MCP to Orange Ave	4 Lane Arterial	35,900	9,100	0.25	C
	South of Orange Ave	4 Lane Arterial	35,900	5,900	0.16	C
Reservoir Ave	North of Martin St	2 Lane Collector	13,000	4,700	0.36	C
	Martin St to MCP	4 Lane Arterial	35,900	7,300	0.20	C
	MCP to 9th St	4 Lane Arterial	35,900	9,500	0.26	C
	South of 9th St	4 Lane Arterial	35,900	10,600	0.30	C
Town Center Blvd	North of Marvin Rd	4 Lane Arterial	35,900	5,400	0.15	C
	Marvin Rd to MCP	4 Lane Arterial	35,900	13,600	0.38	C
	MCP to 5th St	4 Lane Arterial	35,900	14,100	0.39	C
	South of 5th St	4 Lane Arterial	35,900	14,900	0.42	C
Park Center Blvd	Marvin Rd to MCP	4 Lane Arterial	35,900	11,800	0.33	C
	MCP to New St	4 Lane Arterial	35,900	15,600	0.43	C
	South of New St	4 Lane Arterial	35,900	16,400	0.46	C
Warren Rd	North of Ramona Expressway	4 Lane Arterial	35,900	9,200	0.26	C
	Ramona Expressway to MCP	4 Lane Arterial	35,900	12,700	0.35	C
	MCP to Record Rd	4 Lane Arterial	35,900	19,700	0.55	C
	South of Record Rd	4 Lane Arterial	35,900	15,400	0.43	C
Gilman Springs Rd	West of SR-79	4 Lane Arterial	35,900	20,700	0.58	C
	East of SR-79	4 Lane Arterial	35,900	21,100	0.59	C
Ramona Expwy East	Warren Rd to MCP	6 Lane Urban Arterial	53,900	10,300	0.19	C
	South of MCP	6 Lane Urban Arterial	53,900	13,800	0.26	C
Sanderson Ave	North of SR-79	4 Lane Arterial	35,900	13,700	0.38	C
	SR-79 to Cottonwood Ave	4 Lane Arterial	35,900	29,600	0.82	D
	South of Cottonwood Ave	4 Lane Arterial	35,900	21,500	0.60	C
Cottonwood Ave	West of Sanderson Ave	4 Lane Arterial	35,900	17,800	0.50	C
	East of Sanderson Ave	4 Lane Arterial	35,900	20,800	0.58	C

(1) Maximum capacity at level of service E

ADT = Average Daily Traffic

V/C = Volume to Capacity Ratio

LOS = Level of Service

TABLE 9-2 (cont.)
2030 ADT - ALTERNATIVE 4 MODIFIED
FREEWAY SEGMENT CAPACITY ANALYSIS

ROUTE	LIMITS	CLASSIFICATION	TYPICAL MAX ADT (1)	2030 ADT (2)	V/C	LOS
I-15	North of Magnolia Ave	8 Lane Freeway	160,500	183,400	1.14	F
	Magnolia Ave to Ontario Ave	8 Lane Freeway	160,500	179,200	1.12	F
	Ontario Ave to El Cerrito Rd	8 Lane Freeway	160,500	182,200	1.14	F
	El Cerrito Rd to Cajalco Rd	8 Lane Freeway	160,500	179,600	1.12	F
	Cajalco Rd to Weirick Rd	8 Lane Freeway	160,500	170,000	1.06	F
	Weirick Rd to Temescal Cyn Rd	8 Lane Freeway	160,500	156,400	0.97	E
	South of Temescal Cyn Rd	8 Lane Freeway	160,500	150,200	0.94	E
I-215	North of Alessandro Blvd	6 Lane Freeway	117,500	147,200	1.25	F
	Alessandro Blvd to Cactus Ave	6 Lane Freeway	117,500	155,400	1.32	F
	Cactus Ave to Van Buren Blvd	6 Lane Freeway	117,500	160,400	1.37	F
	Van Buren Blvd to Harley Knox Blvd	8 Lane Freeway	160,500	174,800	1.09	F
	Harley Knox Blvd to MCP	10 Lane Freeway	200,600	168,900	0.84	D
	MCP to Placentia Ave	8 Lane Freeway	160,500	122,200	0.76	C
	Placentia Ave to Nuevo Rd	6 Lane Freeway	117,500	122,400	1.04	F
	South of Nuevo Rd	8 Lane Freeway	160,500	122,000	0.76	C
MCP	I-215 to Perris Blvd	6 Lane Freeway	117,500	64,200	0.55	C
	Perris Blvd to Evans Rd	6 Lane Freeway	117,500	69,200	0.59	C
	Evans Rd to Antelope Rd/Ramona Expwy	6 Lane Freeway	117,500	70,600	0.60	C
	Antelope Rd/Ramona Expwy to Bernasconi Rd	6 Lane Freeway	117,500	78,400	0.67	C
	Bernasconi Rd to Reservoir Ave	6 Lane Freeway	117,500	78,400	0.67	C
	Reservoir Ave to Town Center Blvd	6 Lane Freeway	117,500	75,600	0.64	C
	Town Center Blvd to Park Center Blvd	6 Lane Freeway	117,500	64,000	0.54	C
	Park Center Blvd to Warren Rd	6 Lane Freeway	117,500	62,200	0.53	C
	Warren Rd to SR-79	6 Lane Freeway	117,500	51,600	0.44	C
	SR-79 to Ramona Expwy	6 Lane Freeway	117,500	33,000	0.28	C
	East of Ramona Expwy	4 Lane Arterial	35,900	6,400	0.18	C
SR-79	North of Gilman Springs Rd	4 Lane Freeway	76,500	99,000	1.29	F
	Gilman Spring Rd to MCP	4 Lane Freeway	76,500	96,600	1.26	F
	MCP to Sanderson Ave	4 Lane Freeway	76,500	79,000	1.03	F
	West of Sanderson Ave	4 Lane Freeway	76,500	54,200	0.71	C

(1) Maximum capacity at level of service E
(2) Express Lanes on I-15 and HOV Lanes on I-215 not included
ADT = Average Daily Traffic
V/C = Volume to Capacity Ratio
LOS = Level of Service

TABLE 9-3
2030 ADT - ALTERNATIVE 5 MODIFIED
ROADWAY SEGMENT CAPACITY ANALYSIS

ROUTE	LIMITS	CLASSIFICATION	TYPICAL MAX ADT (1)	2030 ADT	V/C	LOS
Cajalco Rd	West of Bedford Cyn Rd	4 Lane Arterial	35,900	17,500	0.49	C
	Bedford Cyn Rd to I-15	4 Lane Arterial	35,900	22,100	0.62	C
	I-15 to Temescal Cyn Rd	4 Lane Arterial	35,900	39,500	1.10	F
	Temescal Cyn Rd to Eagle Valley Dr	4 Lane Arterial	35,900	39,800	1.11	F
	Eagle Valley Dr to Lake Mathews Dr	4 Lane Arterial	35,900	29,600	0.82	D
	Lake Mathews Dr to El Sobrante Rd	4 Lane Arterial	35,900	28,900	0.81	D
	El Sobrante Rd to Wood Rd	4 Lane Arterial	35,900	41,300	1.15	F
	Wood Rd to Alexander St	4 Lane Arterial	35,900	36,300	1.01	F
	Alexander St to Clark St	4 Lane Arterial	35,900	34,900	0.97	E
	Clark St to Harvill Ave	4 Lane Arterial	35,900	38,500	1.07	F
Harvill Ave to I-215	4 Lane Arterial	35,900	39,800	1.11	F	
Magnolia Ave	West of El Sobrante Rd	6 Lane Urban Arterial	53,900	58,700	1.09	F
	El Sobrante Rd to I-15	6 Lane Urban Arterial	53,900	58,600	1.09	F
	I-15 to El Camino Ave	4 Lane Arterial	35,900	54,500	1.52	F
	East of El Camino Ave	4 Lane Arterial	35,900	45,700	1.27	F
Ontario Ave	West of California Ave	6 Lane Urban Arterial	53,900	34,100	0.63	C
	California Ave to I-15	4 Lane Arterial	35,900	40,500	1.13	F
	I-15 to State St	4 Lane Arterial	35,900	30,700	0.86	D
	East of State St	6 Lane Urban Arterial	53,900	31,600	0.59	C
El Cerrito Rd	West of Bedford Cyn Rd	4 Lane Arterial	35,900	19,300	0.54	C
	Bedford Cyn Rd to I-15	4 Lane Arterial	35,900	22,800	0.64	C
	I-15 to Temescal Cyn Rd	4 Lane Arterial	35,900	13,500	0.38	C
Weirick Rd	West of Knabe Rd	2 Lane Collector	13,000	5,400	0.42	C
	Knabe Rd to I-15	4 Lane Arterial	35,900	18,200	0.51	C
	I-15 to Temescal Cyn Rd	4 Lane Arterial	35,900	9,400	0.26	C
Temescal Cyn Rd	West of Lawson Dr	4 Lane Arterial	35,900	14,100	0.39	C
	Lawson Dr to I-15	4 Lane Arterial	35,900	14,500	0.40	C
	I-15 to Weirick Rd	4 Lane Arterial	35,900	13,600	0.38	C
Eagle Valley Dr	North of Cajalco Rd	4 Lane Arterial	35,900	13,500	0.38	C
El Sobrante Rd	North of Cajalco Rd	4 Lane Arterial	35,900	20,400	0.57	C
Wood Rd	North of Cajalco Rd	4 Lane Arterial	35,900	7,100	0.20	C
	South of Cajalco Rd	4 Lane Arterial	35,900	6,500	0.18	C
Alexander St	North of Cajalco Rd	4 Lane Arterial	35,900	3,900	0.11	C
	South of Cajalco Rd	4 Lane Arterial	35,900	4,500	0.13	C
Clark St	North of Cajalco Rd	4 Lane Arterial	35,900	9,300	0.26	C
	South of Cajalco Rd	4 Lane Arterial	35,900	9,700	0.27	C

(1) Maximum capacity at level of service E
ADT = Average Daily Traffic
V/C = Volume to Capacity Ratio
LOS = Level of Service

TABLE 9-3 (continued)
2030 ADT - ALTERNATIVE 5 MODIFIED
ROADWAY SEGMENT CAPACITY ANALYSIS

ROUTE	LIMITS	CLASSIFICATION	TYPICAL MAX ADT (1)	2030 ADT	V/C	LOS
Alessandro Blvd	West of Meridian Pkwy	6 Lane Urban Arterial	53,900	67,800	1.26	F
	Meridian Pkwy to I-215	6 Lane Urban Arterial	53,900	71,300	1.32	F
	I-215 to Valley Springs Pkwy	6 Lane Urban Arterial	53,900	58,800	1.09	F
	East of Valley Springs Pkwy	6 Lane Urban Arterial	53,900	49,100	0.91	E
Cactus Ave	West of Innovation Dr	4 Lane Arterial	35,900	17,100	0.48	C
	Innovation Dr to I-215	6 Lane Urban Arterial	53,900	15,800	0.29	C
	I-215 to Elsworth St	6 Lane Urban Arterial	53,900	41,500	0.77	C
	East of Elsworth St	6 Lane Urban Arterial	53,900	25,000	0.46	C
Van Buren Blvd	West of Meridian Pkwy	6 Lane Urban Arterial	53,900	52,900	0.98	E
	Meridian Pkwy to I-215	6 Lane Urban Arterial	53,900	44,000	0.82	D
	East of I-215	4 Lane Arterial	35,900	11,900	0.33	C
Harley Knox Blvd	West of Harvill Ave	6 Lane Urban Arterial	53,900	21,400	0.40	C
	Harvill to I-215	6 Lane Urban Arterial	53,900	22,200	0.41	C
	I-215 to Western Way	6 Lane Urban Arterial	53,900	13,800	0.26	C
	East of Western Way	6 Lane Urban Arterial	53,900	15,900	0.29	C
Placentia Ave	West of Harvill Ave	4 Lane Arterial	35,900	1,000	0.03	C
	Harvill Ave to I-215	4 Lane Arterial	35,900	15,500	0.43	C
	I-215 to East Frontage Rd	4 Lane Arterial	35,900	15,600	0.43	C
	East of East Frontage Rd	4 Lane Arterial	35,900	13,900	0.39	C
Nuevo Rd	West of A St	4 Lane Arterial	35,900	9,600	0.27	C
	A St to I-215	6 Lane Urban Arterial	53,900	11,900	0.22	C
	I-215 to Old Nuevo	6 Lane Urban Arterial	53,900	13,200	0.24	C
	East of Old Nuevo	6 Lane Urban Arterial	53,900	17,900	0.33	C
Perris Blvd	North of Rider St	6 Lane Urban Arterial	53,900	28,700	0.53	C
	Rider St to MCP	6 Lane Urban Arterial	53,900	34,100	0.63	C
	MCP to Placentia Ave	6 Lane Urban Arterial	53,900	33,600	0.62	C
	South of Placentia Ave	6 Lane Urban Arterial	53,900	31,600	0.59	C
Evans Rd	North of Rider	6 Lane Urban Arterial	53,900	24,700	0.46	C
	Rider to MCP	6 Lane Urban Arterial	53,900	24,300	0.45	C
	MCP to Orange	6 Lane Urban Arterial	53,900	34,700	0.64	C
	South of Orange Ave	6 Lane Urban Arterial	53,900	26,600	0.49	C
Antelope Rd/ Ramona Expressway	North of Rider	4 Lane Arterial	35,900	18,000	0.50	C
	Rider to MCP	4 Lane Arterial	35,900	15,300	0.43	C
	MCP to Orange	4 Lane Arterial	35,900	15,600	0.43	C
	South of Orange Ave	4 Lane Arterial	35,900	2,700	0.08	C

(1) Maximum capacity at level of service E

ADT = Average Daily Traffic

V/C = Volume to Capacity Ratio

LOS = Level of Service

TABLE 9-3 (continued)
2030 ADT - ALTERNATIVE 5 MODIFIED
ROADWAY SEGMENT CAPACITY ANALYSIS

ROUTE	LIMITS	CLASSIFICATION	TYPICAL MAX ADT (1)	2030 ADT	V/C	LOS
Bernasconi Pkwy	North of New St	4 Lane Arterial	35,900	5,400	0.15	C
	New St to MCP	4 Lane Arterial	35,900	8,000	0.22	C
	MCP to Orange Ave	4 Lane Arterial	35,900	9,100	0.25	C
	South of Orange Ave	4 Lane Arterial	35,900	5,900	0.16	C
Reservoir Ave	North of Martin St	2 Lane Collector	13,000	4,700	0.36	C
	Martin St to MCP	4 Lane Arterial	35,900	7,300	0.20	C
	MCP to 9th St	4 Lane Arterial	35,900	11,500	0.32	C
	South of 9th St	4 Lane Arterial	35,900	10,600	0.30	C
Town Center Blvd	North of Marvin Rd	4 Lane Arterial	35,900	6,200	0.17	C
	Marvin Rd to MCP	4 Lane Arterial	35,900	14,900	0.42	C
	MCP to 5th St	4 Lane Arterial	35,900	14,100	0.39	C
	South of 5th St	4 Lane Arterial	35,900	14,900	0.42	C
Park Center Blvd	Marvin Rd to MCP	4 Lane Arterial	35,900	11,700	0.33	C
	MCP to New St	4 Lane Arterial	35,900	15,600	0.43	C
	South of New St	4 Lane Arterial	35,900	16,400	0.46	C
Warren Rd	North of Ramona Expressway	4 Lane Arterial	35,900	9,200	0.26	C
	Ramona Expressway to MCP	4 Lane Arterial	35,900	12,700	0.35	C
	MCP to Record Rd	4 Lane Arterial	35,900	19,800	0.55	C
	South of Record Rd	4 Lane Arterial	35,900	17,400	0.48	C
Gilman Springs Rd	West of SR-79	4 Lane Arterial	35,900	20,500	0.57	C
	East of SR-79	4 Lane Arterial	35,900	21,100	0.59	C
Ramona Expwy East	Warren Rd to MCP	6 Lane Urban Arterial	53,900	10,300	0.19	C
	South of MCP	6 Lane Urban Arterial	53,900	13,800	0.26	C
Sanderson Ave	North of SR-79	4 Lane Arterial	35,900	13,700	0.38	C
	SR-79 to Cottonwood Ave	4 Lane Arterial	35,900	29,600	0.82	D
	South of Cottonwood Ave	4 Lane Arterial	35,900	20,800	0.58	C
Cottonwood Ave	West of Sanderson Ave	4 Lane Arterial	35,900	17,800	0.50	C
	East of Sanderson Ave	4 Lane Arterial	35,900	20,800	0.58	C

(1) Maximum capacity at level of service E

ADT = Average Daily Traffic

V/C = Volume to Capacity Ratio

LOS = Level of Service

TABLE 9-3 (continued)
2030 ADT - ALTERNATIVE 5 MODIFIED
FREEWAY SEGMENT CAPACITY ANALYSIS

ROUTE	LIMITS	CLASSIFICATION	TYPICAL MAX ADT (1)	2030 ADT	V/C	LOS
I-15	North of Magnolia Ave	8 Lane Freeway	160,500	183,400	1.14	F
	Magnolia Ave to Ontario Ave	8 Lane Freeway	160,500	179,200	1.12	F
	Ontario Ave to El Cerrito Rd	8 Lane Freeway	160,500	182,200	1.14	F
	El Cerrito Rd to Cajalco Rd	8 Lane Freeway	160,500	179,600	1.12	F
	Cajalco Rd to Weirick Rd	8 Lane Freeway	160,500	170,000	1.06	F
	Weirick Rd to Temescal Cyn Rd	8 Lane Freeway	160,500	156,400	0.97	E
	South of Temescal Cyn Rd	8 Lane Freeway	160,500	150,200	0.94	E
I-215	North of Alessandro Blvd	6 Lane Freeway	117,500	147,600	1.26	F
	Alessandro Blvd to Cactus Ave	6 Lane Freeway	117,500	153,800	1.31	F
	Cactus Ave to Van Buren Blvd	6 Lane Freeway	117,500	157,200	1.34	F
	Van Buren Blvd to Harley Knox Blvd	8 Lane Freeway	160,500	174,600	1.09	F
	Harley Knox Blvd to Cajalco Rd/Ramona Expwy/MCP	8 Lane Freeway	160,500	169,000	1.05	D
	MCP/Placentia Ave to Nuevo Rd	6 Lane Freeway	117,500	123,200	1.05	F
	South of Nuevo Rd	8 Lane Freeway	160,500	118,400	0.74	C
MCP	I-215 to Perris Blvd	6 Lane Freeway	117,500	67,200	0.57	C
	Perris Blvd to Evans Rd	6 Lane Freeway	117,500	69,400	0.59	C
	Evans Rd to Antelope Rd/Ramona Expwy	6 Lane Freeway	117,500	70,200	0.60	C
	Antelope Rd/Ramona Expwy to Bernasconi Rd	6 Lane Freeway	117,500	78,600	0.67	C
	Bernasconi Rd to Reservoir Ave	6 Lane Freeway	117,500	78,200	0.67	C
	Reservoir Ave to Town Center Blvd	6 Lane Freeway	117,500	74,500	0.63	C
	Town Center Blvd to Park Center Blvd	6 Lane Freeway	117,500	60,800	0.52	C
	Park Center Blvd to Warren Rd	6 Lane Freeway	117,500	62,400	0.53	C
	Warren Rd to SR-79	6 Lane Freeway	117,500	50,000	0.43	C
	SR-79 to Ramona Expwy	6 Lane Freeway	117,500	33,600	0.29	C
	East of Ramona Expwy	4 Lane Arterial	35,900	6,400	0.18	C
SR-79	North of Gilman Springs Rd	4 Lane Freeway	76,500	99,000	1.29	F
	Gilman Spring Rd to MCP	4 Lane Freeway	76,500	96,800	1.27	F
	MCP to Sanderson Ave	4 Lane Freeway	76,500	79,000	1.03	F
	West of Sanderson Ave	4 Lane Freeway	76,500	54,200	0.71	C

- (1) Maximum capacity at level of service E
(2) Express Lanes on I-15 and HOV Lanes on I-215 not included
ADT = Average Daily Traffic
V/C = Volume to Capacity Ratio
LOS = Level of Service

TABLE 9-4
2030 ADT - ALTERNATIVE 9 MODIFIED
ROADWAY SEGMENT CAPACITY ANALYSIS

ROUTE	LIMITS	CLASSIFICATION	TYPICAL MAX ADT (1)	2030 ADT	V/C	LOS
Cajalco Rd	West of Bedford Cyn Rd	4 Lane Arterial	35,900	17,500	0.49	C
	Bedford Cyn Rd to I-15	4 Lane Arterial	35,900	22,100	0.62	C
	I-15 to Temescal Cyn Rd	4 Lane Arterial	35,900	39,700	1.11	F
	Temescal Cyn Rd to Eagle Valley Dr	4 Lane Arterial	35,900	40,000	1.11	F
	Eagle Valley Dr to Lake Mathews Dr	4 Lane Arterial	35,900	30,700	0.86	D
	Lake Mathews Dr to El Sobrante Rd	4 Lane Arterial	35,900	29,100	0.81	D
	El Sobrante Rd to Wood Rd	4 Lane Arterial	35,900	41,700	1.16	F
	Wood Rd to Alexander St	4 Lane Arterial	35,900	36,700	1.02	F
	Alexander St to Clark St	4 Lane Arterial	35,900	35,200	0.98	E
	Clark St to Harvill Ave	4 Lane Arterial	35,900	38,900	1.08	F
Harvill Ave to I-215	4 Lane Arterial	35,900	38,500	1.07	F	
Magnolia Ave	West of El Sobrante Rd	6 Lane Urban Arterial	53,900	58,700	1.09	F
	El Sobrante Rd to I-15	6 Lane Urban Arterial	53,900	58,600	1.09	F
	I-15 to El Camino Ave	4 Lane Arterial	35,900	54,500	1.52	F
	East of El Camino Ave	4 Lane Arterial	35,900	45,700	1.27	F
Ontario Ave	West of California Ave	6 Lane Urban Arterial	53,900	34,100	0.63	C
	California Ave to I-15	4 Lane Arterial	35,900	40,500	1.13	F
	I-15 to State St	4 Lane Arterial	35,900	30,700	0.86	D
	East of State St	6 Lane Urban Arterial	53,900	31,600	0.59	C
El Cerrito Rd	West of Bedford Cyn Rd	4 Lane Arterial	35,900	19,300	0.54	C
	Bedford Cyn Rd to I-15	4 Lane Arterial	35,900	22,800	0.64	C
	I-15 to Temescal Cyn Rd	4 Lane Arterial	35,900	13,500	0.38	C
Weirick Rd	West of Knabe Rd	2 Lane Collector	13,000	5,400	0.42	C
	Knabe Rd to I-15	4 Lane Arterial	35,900	18,200	0.51	C
	I-15 to Temescal Cyn Rd	4 Lane Arterial	35,900	9,400	0.26	C
Temescal Cyn Rd	West of Lawson Dr	4 Lane Arterial	35,900	14,100	0.39	C
	Lawson Dr to I-15	4 Lane Arterial	35,900	14,500	0.40	C
	I-15 to Weirick Rd	4 Lane Arterial	35,900	13,600	0.38	C
Eagle Valley Dr	North of Cajalco Rd	4 Lane Arterial	35,900	13,500	0.38	C
El Sobrante Rd	North of Cajalco Rd	4 Lane Arterial	35,900	20,600	0.57	C
Wood Rd	North of Cajalco Rd	4 Lane Arterial	35,900	7,100	0.20	C
	South of Cajalco Rd	4 Lane Arterial	35,900	6,500	0.18	C
Alexander St	North of Cajalco Rd	4 Lane Arterial	35,900	3,900	0.11	C
	South of Cajalco Rd	4 Lane Arterial	35,900	4,500	0.13	C
Clark St	North of Cajalco Rd	4 Lane Arterial	35,900	9,300	0.26	C
	South of Cajalco Rd	4 Lane Arterial	35,900	9,700	0.27	C

(1) Maximum capacity at level of service E
ADT = Average Daily Traffic
V/C = Volume to Capacity Ratio
LOS = Level of Service

TABLE 9-4 (continued)
 2030 ADT - ALTERNATIVE 9 MODIFIED
 ROADWAY SEGMENT CAPACITY ANALYSIS

ROUTE	LIMITS	CLASSIFICATION	TYPICAL MAX ADT (1)	2030 ADT	V/C	LOS
Alessandro Blvd	West of Meridian Pkwy	6 Lane Urban Arterial	53,900	67,000	1.24	F
	Meridian Pkwy to I-215	6 Lane Urban Arterial	53,900	71,000	1.32	F
	I-215 to Valley Springs Pkwy	6 Lane Urban Arterial	53,900	58,400	1.08	F
	East of Valley Springs Pkwy	6 Lane Urban Arterial	53,900	49,100	0.91	E
Cactus Ave	West of Innovation Dr	4 Lane Arterial	35,900	17,100	0.48	C
	Innovation Dr to I-215	6 Lane Urban Arterial	53,900	15,800	0.29	C
	I-215 to Elsworth St	6 Lane Urban Arterial	53,900	41,500	0.77	C
	East of Elsworth St	6 Lane Urban Arterial	53,900	25,000	0.46	C
Van Buren Blvd	West of Meridian Pkwy	6 Lane Urban Arterial	53,900	52,200	0.97	E
	Meridian Pkwy to I-215	6 Lane Urban Arterial	53,900	43,300	0.80	D
	East of I-215	4 Lane Arterial	35,900	3,700	0.10	C
Harley Knox Blvd	West of Harvill Ave	6 Lane Urban Arterial	53,900	21,400	0.40	C
	Harvill to I-215	6 Lane Urban Arterial	53,900	22,000	0.41	C
	I-215 to Western Way	6 Lane Urban Arterial	53,900	19,300	0.36	C
	East of Western Way	6 Lane Urban Arterial	53,900	16,400	0.30	C
Placentia Ave	West of Harvill Ave	4 Lane Arterial	35,900	2,400	0.07	C
	Harvill Ave to I-215	4 Lane Arterial	35,900	18,200	0.51	C
	I-215 to East Frontage Rd	4 Lane Arterial	35,900	18,200	0.51	C
	East of East Frontage Rd	4 Lane Arterial	35,900	16,600	0.46	C
Nuevo Rd	West of A St	4 Lane Arterial	35,900	11,200	0.31	C
	A St to I-215	6 Lane Urban Arterial	53,900	12,300	0.23	C
	I-215 to Old Nuevo	6 Lane Urban Arterial	53,900	14,300	0.27	C
	East of Old Nuevo	6 Lane Urban Arterial	53,900	17,000	0.32	C
Redlands Ave	North of Rider St	4 Lane Arterial	35,900	14,600	0.41	C
	Rider St to MCP	4 Lane Arterial	35,900	14,200	0.40	C
	MCP to Placentia Ave	4 Lane Arterial	35,900	20,200	0.56	C
	South of Placentia Ave	4 Lane Arterial	35,900	18,300	0.51	C
Evans Rd	North of Rider	6 Lane Urban Arterial	53,900	26,700	0.50	C
	Rider to MCP	6 Lane Urban Arterial	53,900	27,300	0.51	C
	MCP to Orange	6 Lane Urban Arterial	53,900	33,000	0.61	C
	South of Orange Ave	6 Lane Urban Arterial	53,900	25,600	0.47	C
Antelope Rd/ Ramona Expressway	North of Rider	4 Lane Arterial	35,900	20,800	0.58	C
	Rider to MCP	4 Lane Arterial	35,900	21,000	0.58	C
	MCP to Orange	4 Lane Arterial	35,900	16,000	0.45	C
	South of Orange Ave	4 Lane Arterial	35,900	2,700	0.08	C

(1) Maximum capacity at level of service E
 ADT = Average Daily Traffic
 V/C = Volume to Capacity Ratio
 LOS = Level of Service

TABLE 9-4 (continued)
2030 ADT - ALTERNATIVE 9 MODIFIED
ROADWAY SEGMENT CAPACITY ANALYSIS

ROUTE	LIMITS	CLASSIFICATION	TYPICAL MAX ADT (1)	2030 ADT	V/C	LOS
Bernasconi Rd	North of New St	4 Lane Arterial	35,900	5,400	0.15	C
	New St to MCP	4 Lane Arterial	35,900	8,000	0.22	C
	MCP to Orange Ave	4 Lane Arterial	35,900	9,100	0.25	C
	South of Orange Ave	4 Lane Arterial	35,900	5,900	0.16	C
Reservoir Ave	North of Martin St	2 Lane Collector	13,000	4,700	0.36	C
	Martin St to MCP	4 Lane Arterial	35,900	7,300	0.20	C
	MCP to 9th St	4 Lane Arterial	35,900	11,100	0.31	C
	South of 9th St	4 Lane Arterial	35,900	10,000	0.28	C
Town Center Blvd	North of Marvin Rd	4 Lane Arterial	35,900	6,200	0.17	C
	Marvin Rd to MCP	4 Lane Arterial	35,900	15,000	0.42	C
	MCP to 5th St	4 Lane Arterial	35,900	14,000	0.39	C
	South of 5th St	4 Lane Arterial	35,900	14,900	0.42	C
Park Center Blvd	Marvin Rd to MCP	4 Lane Arterial	35,900	11,800	0.33	C
	MCP to New St	4 Lane Arterial	35,900	15,600	0.43	C
	South of New St	4 Lane Arterial	35,900	16,300	0.45	C
Warren Rd	North of Ramona Expressway	4 Lane Arterial	35,900	9,200	0.26	C
	Ramona Expressway to MCP	4 Lane Arterial	35,900	12,200	0.34	C
	MCP to Record Rd	4 Lane Arterial	35,900	19,600	0.55	C
	South of Record Rd	4 Lane Arterial	35,900	19,500	0.54	C
Gilman Springs Rd	West of SR-79	4 Lane Arterial	35,900	21,400	0.60	C
	East of SR-79	4 Lane Arterial	35,900	21,100	0.59	C
Ramona Expwy East	Warren Rd to MCP	6 Lane Urban Arterial	53,900	10,300	0.19	C
	South of MCP	6 Lane Urban Arterial	53,900	13,800	0.26	C
Sanderson Ave	North of SR-79	4 Lane Arterial	35,900	13,700	0.38	C
	SR-79 to Cottonwood Ave	4 Lane Arterial	35,900	29,600	0.82	D
	South of Cottonwood Ave	4 Lane Arterial	35,900	20,600	0.57	C
Cottonwood Ave	West of Sanderson Ave	4 Lane Arterial	35,900	17,800	0.50	C
	East of Sanderson Ave	4 Lane Arterial	35,900	20,800	0.58	C

(1) Maximum capacity at level of service E

ADT = Average Daily Traffic

V/C = Volume to Capacity Ratio

LOS = Level of Service

TABLE 9-4 (continued)
2030 ADT - ALTERNATIVE 9 MODIFIED
FREEWAY SEGMENT CAPACITY ANALYSIS

ROUTE	LIMITS	CLASSIFICATION	TYPICAL MAX ADT (1)	2030 ADT	V/C	LOS
I-15	North of Magnolia Ave	8 Lane Freeway	160,500	183,600	1.14	F
	Magnolia Ave to Ontario Ave	8 Lane Freeway	160,500	179,400	1.12	F
	Ontario Ave to El Cerrito Rd	8 Lane Freeway	160,500	182,400	1.14	F
	El Cerrito Rd to Cajalco Rd	8 Lane Freeway	160,500	179,800	1.12	F
	Cajalco Rd to Weirick Rd	8 Lane Freeway	160,500	170,000	1.06	F
	Weirick Rd to Temescal Cyn Rd	8 Lane Freeway	160,500	156,400	0.97	E
	South of Temescal Cyn Rd	8 Lane Freeway	160,500	150,200	0.94	E
I-215	North of Alessandro Blvd	6 Lane Freeway	117,500	145,600	1.24	F
	Alessandro Blvd to Cactus Ave	6 Lane Freeway	117,500	153,600	1.31	F
	Cactus Ave to Van Buren Blvd	6 Lane Freeway	117,500	158,600	1.35	F
	Van Buren Blvd to Harley Knox Blvd	8 Lane Freeway	160,500	169,200	1.05	F
	Harley Knox Blvd to Cajalco Rd/Ramona Expwy	8 Lane Freeway	160,500	169,000	1.05	F
	Cajalco Rd/Ramona Expwy to MCP	10 Lane Freeway	200,600	166,400	0.83	D
	MCP to Nuevo Rd	8 Lane Freeway	160,500	115,200	0.72	C
	South of Nuevo Rd	8 Lane Freeway	160,500	120,000	0.75	C
MCP	I-215 to Perris Blvd	6 Lane Freeway	117,500	63,800	0.54	C
	Perris Blvd to Evans Rd	6 Lane Freeway	117,500	66,800	0.57	C
	Evans Rd to Antelope Rd/Ramona Expwy	6 Lane Freeway	117,500	66,200	0.56	C
	Antelope Rd/Ramona Expwy to Bernasconi Rd	6 Lane Freeway	117,500	78,800	0.67	C
	Bernasconi Rd to Reservoir Ave	6 Lane Freeway	117,500	78,800	0.67	C
	Reservoir Ave to Town Center Blvd	6 Lane Freeway	117,500	75,800	0.65	C
	Town Center Blvd to Park Center Blvd	6 Lane Freeway	117,500	58,200	0.50	C
	Park Center Blvd to Warren Rd	6 Lane Freeway	117,500	62,600	0.53	C
	Warren Rd to SR-79	6 Lane Freeway	117,500	49,400	0.42	C
	SR-79 to Ramona Expwy	6 Lane Freeway	117,500	33,600	0.29	C
	East of Ramona Expwy	4 Lane Arterial	35,900	6,400	0.18	C
SR-79	North of Gilman Springs Rd	4 Lane Freeway	76,500	99,200	1.30	F
	Gilman Spring Rd to MCP	4 Lane Freeway	76,500	97,400	1.27	F
	MCP to Sanderson Ave	4 Lane Freeway	76,500	79,000	1.03	F
	West of Sanderson Ave	4 Lane Freeway	76,500	54,200	0.71	C

(1) Maximum capacity at level of service E
(2) Express Lanes on I-15 and HOV Lanes on I-215 not included
ADT = Average Daily Traffic
V/C = Volume to Capacity Ratio
LOS = Level of Service

10.0 SUMMARY OF RESULTS AND CONCLUSIONS

This chapter provides a summary of results and conclusions. It includes a discussion of project benefits and impacts, a description of the level of service (LOS) concept, which is used in the evaluation of traffic conditions, and a summary of traffic conditions for Existing (2010) conditions, Opening Year (2020) No Build and Build conditions, and Horizon Year (2040) No Build and Build conditions.

PROJECT BENEFITS

The Mid County Parkway (MCP) project provides three primary benefits to the transportation system, as described below and summarized in Figures 10-1 through 10-3.

- ◆ **Improved Travel Times:** The MCP project would significantly improve east-west vehicle travel times along the MCP/Ramona Expressway corridor between I-215 and SR-79. Without the project, the 2040 average peak hour travel time from I-215 to SR-79 is expected to be 44.3 minutes. With the MCP, the 2040 average peak hour travel time is expected to range from 14.2 minutes to 15.9 minutes, depending on the alternative. Figure 10-1 illustrates this benefit. Appendix D includes additional information on travel time calculations.
- ◆ **Reduction in Traffic Congestion or Elimination of Traffic Congestion Along Parallel Roadways:** The primary parallel roadway that would experience traffic congestion relief from the MCP project is the Ramona Expressway. This is illustrated in Figure 10-2. In the area between I-215 and Perris Boulevard, the project would reduce 2040 Average Daily Traffic (ADT) along Ramona Expressway from 79,000 in the No Build condition to 47,000 to 52,000 depending on the alternative. In the area between Perris Boulevard and Rider Street, the project would reduce ADT from approximately 60,000 to 24,000 to 28,000 depending on the alternative. In the area from Rider Street to SR-79, the MCP would replace Ramona Expressway with a high-speed, limited-access facility that would provide improved traffic operations for travelers along this corridor. Examples of other roadways that would experience traffic congestion relief due to the MCP project would include SR-60 east of I-215 and SR-74 east of I-215. Along SR-60 east of I-215, the project would reduce 2040 ADT from 166,800 in the No Build condition to a range of 160,300 to 161,500 depending on the alternative. Along SR-74 west of SR-79, the project would reduce 2040 ADT from 25,700 in the No Build condition to a range of 22,600 to 22,900 depending on the alternative.
- ◆ **Improvement in Traffic Operations Along I-215:** The MCP is expected to add traffic to the I-215 freeway from the I-215/MCP interchange north to Van Buren Boulevard. The project also includes the construction of additional travel lanes along I-215 from Nuevo Road to Van Buren Boulevard. The improvement in traffic operations from the additional lanes outweighs the effect of the additional traffic and the net effect is an improvement in traffic operations along I-215 from Nuevo Road to Van Buren Boulevard with the project as compared to the No Build condition. This is illustrated in Figure 10-3 for 2040 conditions. The level of improvement along I-215 varies somewhat among the alternatives and for various segments of I-215. In some cases, the project improves the operating condition of I-215 from a congested situation (LOS E or F) to a non-congested situation (level of service C or D). In other

cases, traffic operations are expected to be congested with the project, but at a lesser level of traffic congestion than in the No Build condition. The end result is reduced traffic congestion and improved travel times for through traffic on I-215 with the implementation of the MCP project.

PROJECT TRAFFIC IMPACTS

Although the MCP project generally increases roadway capacity and mobility in the traffic analysis study area, there are locations where the project causes a redistribution of traffic that is expected to add traffic to a particular roadway segment. Although the project is expected to add traffic to a number of roadway segments, a detailed examination of the locations where the project is expected to add traffic to the street system has concluded that there are no locations where the project would cause a significant traffic impact. In some cases (such as I-215 from the I-215/MCP interchange and Placentia Avenue in the I-215/Placentia Avenue interchange area), the project is expected to add traffic but also add improvements to the roadway segment that would experience a traffic increase, thereby producing a net benefit to traffic operations. In other cases (such as SR-79 near the MCP/SR-79 interchange), the project would be expected to add traffic, but the roadway that would be expected to experience a traffic increase is planned to have adequate capacity to accommodate 2040 traffic with the MCP project. There is also a third type of situation where the MCP project would be expected to add traffic to another roadway, but the traffic increase would be insignificant. An example of this situation is the segment of I-15 between Cajalco Road and SR-91. Further discussion of project traffic impacts is included in the remainder of this chapter and in Chapter 8, Traffic Impacts and Mitigation.

LEVEL OF SERVICE

The summary of results and conclusions in this chapter provides an overview of the results as well as a comparison of the Build and No Build alternatives from a traffic analysis point of view. The results and conclusions are based primarily on roadway and intersection operations, expressed in terms of level of service.

Roadway and intersection operations are typically described in terms of levels of service (LOS) ranging from LOS A (light traffic, minimal delays) to LOS F (traffic congestion and substantial delays). Depending on local conditions, levels of service C, D, and E are all used as the design target for various traffic engineering applications.

For the purposes of this analysis, roadway levels of service were evaluated as follows:

- ◆ Levels of service A, B, and C were considered as an indication that there would be no traffic operational problems and that most or all drivers would be satisfied with the resulting traffic conditions. LOS C or better conditions would be considered to be the ideal LOS target for new roadway facilities (including the MCP).
- ◆ LOS D was considered to provide a reasonable level of traffic operations for peak hour conditions that would be considered satisfactory for most drivers. A roadway design concept that could achieve LOS D would be recommended where substantial cost increases or other considerations would make it difficult to achieve LOS C.

- ◆ LOS E and F were considered to indicate potential traffic congestion and were therefore considered to be undesirable. LOS E was considered to be an indication that the roadway or intersection under study would operate at or near capacity with levels of delay that would be considered unsatisfactory to most drivers. LOS F was considered to be an indication that the roadway or intersection would be over capacity. Under LOS F conditions, drivers would experience substantial delays and some drivers would choose other routes or other time periods to make their trips. Although LOS E and F conditions are considered to be undesirable, they are often an indication of a potential problem and a need for further consideration. This is particularly true for LOS E or F conditions that are predicted for the future, where plans for roadway facilities and/or land development could be modified to resolve a level or service E or F condition that is predicted in this report.

The remainder of this chapter provides an evaluation of Existing (2010) conditions and Horizon Year (2040) conditions for each of the alternatives under study.

EXISTING (2010) CONDITIONS

Existing freeways and intersections were analyzed for 2010 conditions and the results were provided in Tables 3-1 through 3-3. Within the MCP traffic analysis study area, traffic congestion currently occurs during peak periods along the entire length of I-15, several locations along I-215, and at various intersections located throughout the study area.

Following is a summary of the LOS conditions for freeway segments under 2010 conditions. It should be noted that, for the purposes of this table and similar tables, a freeway segment is defined as a one-way section of roadway between adjacent interchanges. For example, I-215 between Harley Knox Boulevard and Van Buren Boulevard includes one northbound and one southbound freeway segment. Since the various freeway segments vary in length between the scenarios, this is not considered to be an ideal comparison, but it is shown for informational purposes.

<u>Level of Service</u>	<u>Number of Freeway Segments</u>	<u>Percent</u>
A, B or C	2	7%
D	9	32%
E	8	29%
F	9	32%
Total	28	100%

Following is a summary of the LOS conditions for intersections under 2010 conditions:

<u>Level of Service</u>	<u>Number of Intersections</u>	<u>Percent</u>
A, B or C	52	69%
D	11	15%
E	5	7%
F	7	9%
Total	75	100%

The results for existing conditions indicate that traffic congestion is present in the study area. In the case of freeways, 17 of 28 freeway segments experience LOS E or F conditions. This is primarily due to traffic congestion on I-15 in the area south of SR-91. In the case of intersections, 12 of 75 intersections experience LOS E or F conditions. This is primarily due to traffic congestion at the I-15/Magnolia Avenue and I-215/Alessandro Boulevard intersections, as well as a few scattered intersections where traffic signals are desirable, but have not yet been installed.

OPENING YEAR (2020) CONDITIONS

Opening Year (2020) conditions assume that a portion of the MCP improvements would be built as part of a phased implementation of the overall project, as described in Chapter 2. The portion of the project assumed to be built by 2020 includes the following:

- ◆ New four-lane freeway from west of Reservoir Avenue to east of Park Center Boulevard, including grade-separated interchanges at Reservoir Avenue, Town Center Boulevard, and Park Center Boulevard
- ◆ Widening of Ramona Expressway from two lanes to four lanes from west of Bernasconi Road to west of Reservoir Avenue
- ◆ Widening of Ramona Expressway from two lanes to four lanes from east of Park Center Boulevard to west of Warren Road
- ◆ Widening of I-215 to add one mixed-flow lane in each direction from Nuevo Road to Van Buren Boulevard, resulting in four mixed-flow lanes in each direction.
- ◆ New interchange on I-215 at Placentia Avenue

The improvements described above for the phased implementation of the MCP are common to Alternatives 4 Modified, Alternative 5 Modified, and Alternative 9 Modified.

In general, regional roadway improvements were included in the assumptions for 2020 conditions if the proposed roadway improvement was included in the Southern California Association of Governments (SCAG's) 2008 Regional Transportation Plan (RTP), including approved amendments.

Key conclusions of the 2020 conditions traffic analysis can be summarized as follows:

- ◆ Under 2020 No Build conditions, traffic congestion is expected within the MCP traffic analysis study area along I-15, portions of I-215, portions of Ramona Expressway, and at various intersections located throughout the study area.
- ◆ As an example of the traffic reduction along Ramona Expressway in the area east of I-215, this facility would be expected to carry 49,700 vehicles per day under No Build conditions and 35,800 vehicles per day under Build conditions.
- ◆ Under 2020 Build conditions, the proposed MCP (located between Bernasconi Road and Warren Road) would be expected to carry ADT ranging from approximately 33,000 to 40,000.
- ◆ The benefits of the proposed project would include improvement of operations along Ramona Expressway to LOS D or better, reduction in traffic levels along parallel facilities, such as SR-60, improvement of traffic operations along I-215, and provision of a high-speed facility that would improve travel times for travelers in the MCP corridor.
- ◆ The proposed Mid County Parkway facility would be expected to add traffic to I-215 between the MCP and Van Buren Boulevard. However, the MCP project includes the addition of traffic lanes along I-215 between Nuevo Road and Van Buren Boulevard, as noted above. With the addition of traffic added by the MCP project and the added traffic lanes, operations on I-215 are expected to improve as compared to the 2020 No Build condition.
- ◆ The MCP is expected to add approximately 500 vehicles per day to Cajalco Road between I-215 and I-15 and approximately 400 vehicles per day to I-15 between the MCP and SR-91. However, the traffic increase contributed by the MCP project is considered to be relatively small and additional improvements along these facilities are unnecessary. Under Build conditions, Cajalco Road between I-215 and I-15 is expected to carry up to 25,500 vehicles per day, a level of traffic that can easily be accommodated by the Four-Lane Expressway that is expected to be implemented by 2020.

Mid County Parkway Traffic Technical Report

Following is a summary of the LOS conditions for freeway segments under 2020 conditions:

<u>Level of Service</u>	<u>No Build</u>		<u>Build</u>	
	<u>Segments</u>	<u>Percent</u>	<u>Segments</u>	<u>Percent</u>
A, B or C	1	4%	9	24%
D	11	39%	14	37%
E	4	14%	8	21%
F	12	43%	7	18%
Total	28	100%	38	100%

Following is a summary of the LOS conditions for intersections under 2020 conditions:

<u>Level of Service</u>	<u>No Build</u>		<u>Build</u>	
	<u>Intersections</u>	<u>Percent</u>	<u>Intersections</u>	<u>Percent</u>
A, B or C	59	72%	69	79%
D	15	18%	11	13%
E	4	5%	3	3%
F	4	5%	04	5%
Total	82	100%	87	100%

The results for 2020 conditions indicate a lessening of freeway traffic congestion with the project and essentially no change in intersection traffic congestion. In the case of freeways, there is an overall increase in the number of freeway segments experiencing LOS A,B, or C conditions due to the addition of the project freeway segments, all of which fall into this category. In addition, the number of freeway segments experiencing LOS F is reduced, due to the addition of mainline lanes on I-215 that is part of the project improvements. In the case of intersections, the project adds a number of intersections that experience LOS A, B, or C and reduces the number of intersections operating at LOS D. There is essentially no change in the number of intersections operating at levels of service E or F. The LOS E and F locations are generally locations where the traffic congestion would occur in the No Build condition and project traffic does not cause an adverse traffic impact.

HORIZON YEAR (2040) CONDITIONS

Horizon Year (2040) conditions assume the construction of the MCP and a number of regional and local roadway improvements, as described in Chapter 2. In general, regional roadway improvements were included in the assumptions for future conditions if the proposed roadway improvement was included in the SCAG's 2008 RTP (including approved amendments). Local roadway improvements were included in the assumptions for future roadway conditions if they were included in the Circulation Element of the General Plan for the appropriate local jurisdiction.

Key conclusions of the traffic analysis of 2040 conditions can be summarized as follows:

- ◆ Under 2040 No Build conditions, traffic congestion is expected within the MCP traffic analysis study area along I-215, portions of I-215, portions of Ramona Expressway, and at various intersections located throughout the study area.
- ◆ As an example of the traffic reduction along Ramona Expressway in the area east of I-215, this facility would be expected to carry 79,000 vehicles per day under No Build conditions and 47,100 to 52,700 vehicles per day under Build conditions, with some variation between the various alternatives.
- ◆ Under 2040 Build conditions, the proposed MCP facility is expected to carry ADT ranging from approximately 50,000 to 90,000 vehicles per day depending on the location and alternative.
- ◆ The benefits of the proposed project (under all Build alternatives) would include improvement of operations along Ramona Expressway to LOS D or better, reduction in traffic levels along parallel facilities, such as SR-60, improvement of traffic operations along I-215, and provision of a high-speed facility that would improve travel times for travelers in the MCP corridor.
- ◆ The proposed MCP facility would be expected to add traffic to I-215 between the MCP and Van Buren Boulevard. However, the MCP project includes the addition of traffic lanes along I-215 between Nuevo Road and Van Buren Boulevard as noted above. With the addition of traffic added by the MCP project and the added traffic lanes, operations on I-215 are expected to improve as compared to the 2040 No Build condition.
- ◆ The MCP is expected to add approximately 1,600 vehicles per day to Cajalco Road between I-215 and I-15 and approximately 1,000 vehicles per day to I-15 between the MCP and SR-91. However, the traffic increase contributed by the MCP project is considered to be relatively small and additional improvements along these facilities are unnecessary. Under Build conditions, Cajalco Road between I-215 and I-15 is expected to carry up to 59,700 vehicles per day to 59,900 vehicles per day (with some variation between the various alternatives). The traffic analysis indicates that this level of traffic can be accommodated by the Six-Lane Expressway that is expected to be implemented along Cajalco Road by 2040.
- ◆ Alternatives 4 Modified and 5 Modified would provide an interchange at Perris Boulevard, while Alternative 9 Modified would provide an interchange at Redlands Avenue instead of Perris Boulevard.

Mid County Parkway Traffic Technical Report

Under Alternative 9 Modified, access to Cajalco Road west of I-215 would be improved, since access to Cajalco Road would be provided directly using the MCP and I-215 freeways. In contrast, under Alternatives 4 Modified and 5 Modified, traffic destined for Cajalco Road west of I-215 would need to exit the MCP at Perris Boulevard and would need to travel along surface streets to access Cajalco Road.

Traffic levels along the MCP are expected to vary somewhat between the alternatives, particularly in the area east of I-215. Alternative 5 Modified would be expected to carry 77,200 vehicles per day, while Alternatives 4 Modified and 9 Modified would be expected to carry 69,800 and 76,200 vehicles per day, respectively. The highest levels of traffic are expected to occur near the center of the project between Bernasconi Road and Reservoir Avenue. In this area, Alternative 4 Modified is expected to carry 93,600, while Alternatives 5 Modified and 9 Modified are expected to carry 93,400 and 93,800 vehicles per day, respectively. At the east end of the project between Warren Road and SR-79, Alternative 4 Modified is expected to carry 59,200 vehicles per day while Alternatives 5 Modified and 9 Modified are expected to carry 55,600 and 55,000 vehicles per day.

Following is a summary of the LOS conditions for freeway segments under 2040 conditions:

Level of Service	No Build		Alt 4M		Alt 5M		Alt 9M	
	Segments	Percent	Segments	Percent	Segments	Percent	Segments	Percent
A, B or C	0	0%	19	38%	17	34%	17	40%
D	1	4%	3	12%	2	8%	3	11%
E	4	15%	5	12%	5	14%	6	15%
F	21	81%	18	38%	20	44%	18	34%
Total	26	100%	45	100%	44	100%	44	100%

Note: Alt #M means Alternative # Modified.

Following is a summary of the LOS conditions for intersections under 2040 conditions:

Level of Service	No Build		Alt 4M		Alt 5M		Alt 9M	
	Intersections	Percent	Intersections	Percent	Intersections	Percent	Intersections	Percent
A, B, C	51	63%	67	69%	70	73%	69	71%
D	15	19%	15	16%	15	16%	17	18%
E	5	6%	2	2%	2	2%	3	3%
F	10	12%	13	13%	9	9%	8	8%
Total	81	100%	97	100%	96	100%	97	100%

Note: Alt #M means Alternative # Modified.

The results for 2040 conditions indicate an increase in the number of freeway segments and intersections that experience LOS A, B, or C for all of the Build alternatives as compared to the No Build condition. This is due to the addition of project freeway segments and intersections, nearly all of which fall into this category. In addition, there is some reduction in the number of freeway segments experiencing LOS F, due to the addition of mainline lanes along I-215 which are part of the project improvements. There is essentially no change in the number of intersections operating at levels of service E or F. The LOS E and F locations are generally locations where the traffic congestion would occur in the No Build condition and project traffic does not cause an adverse traffic impact. On an overall basis, the results do not indicate any substantial difference between Alternatives 4 Modified, 5 Modified, and 9 Modified. Each alternative provides benefits, but none of the three is more or less beneficial than the others.

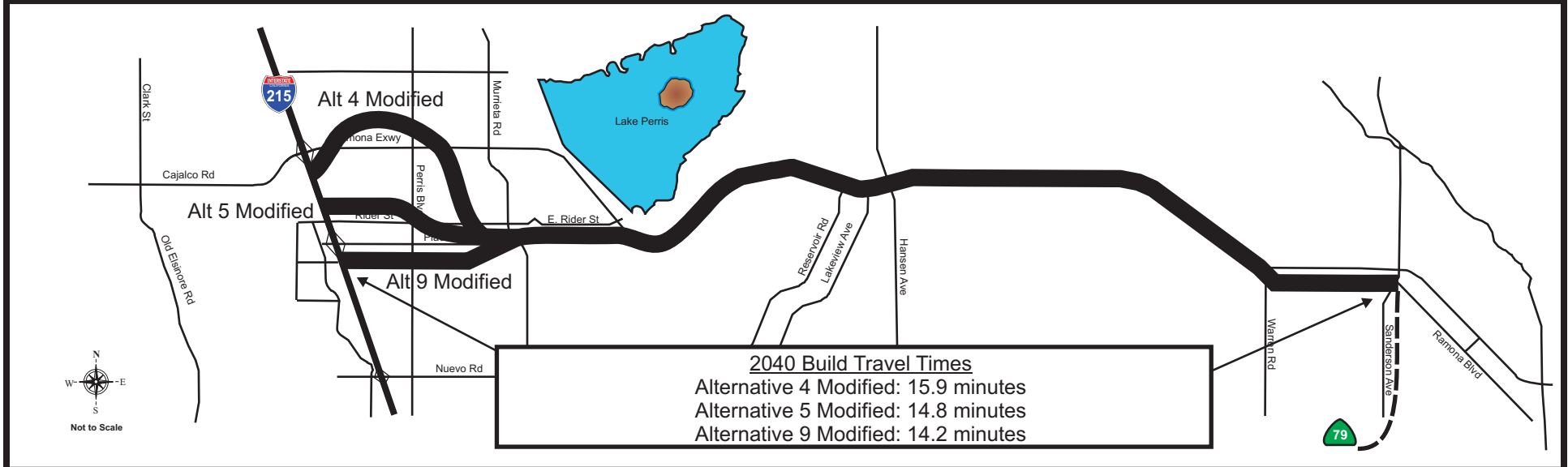
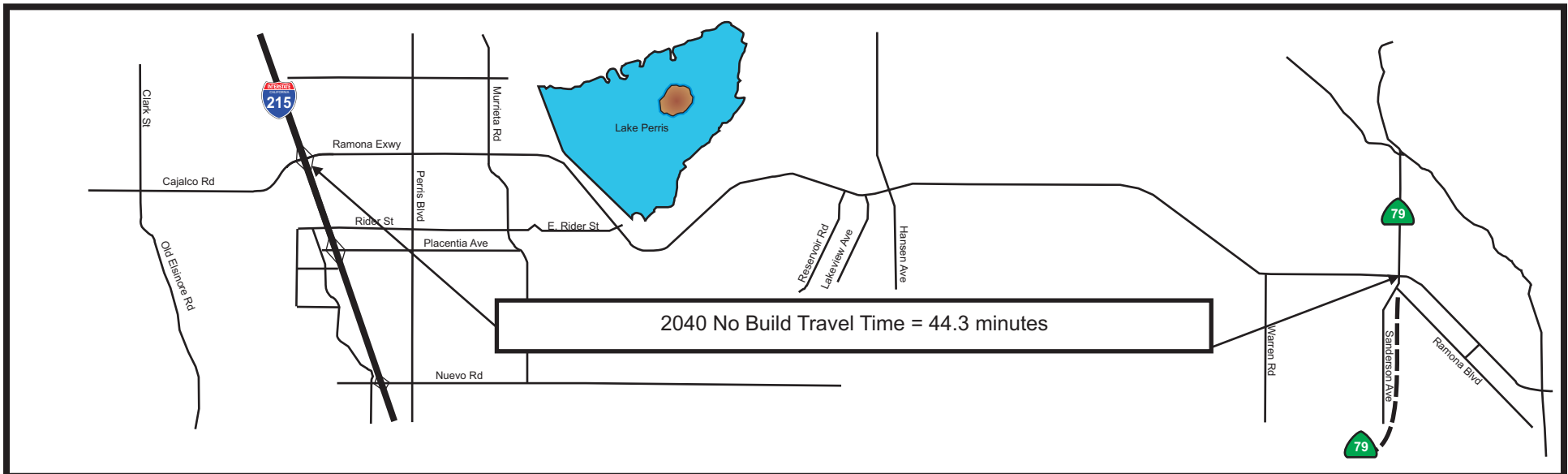

Horizon Year (2040) Vehicle Travel Time Between I-215 and SR-79

Figure 10-1

Legend

-  Proposed Mid County Parkway
-  Proposed SR-79



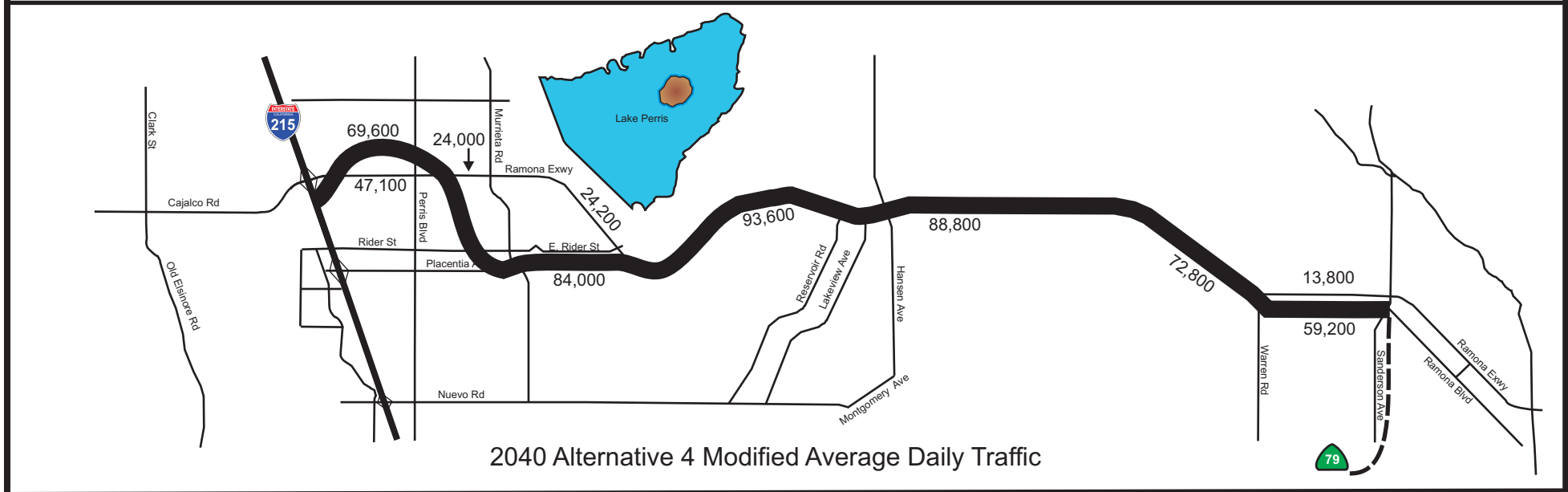
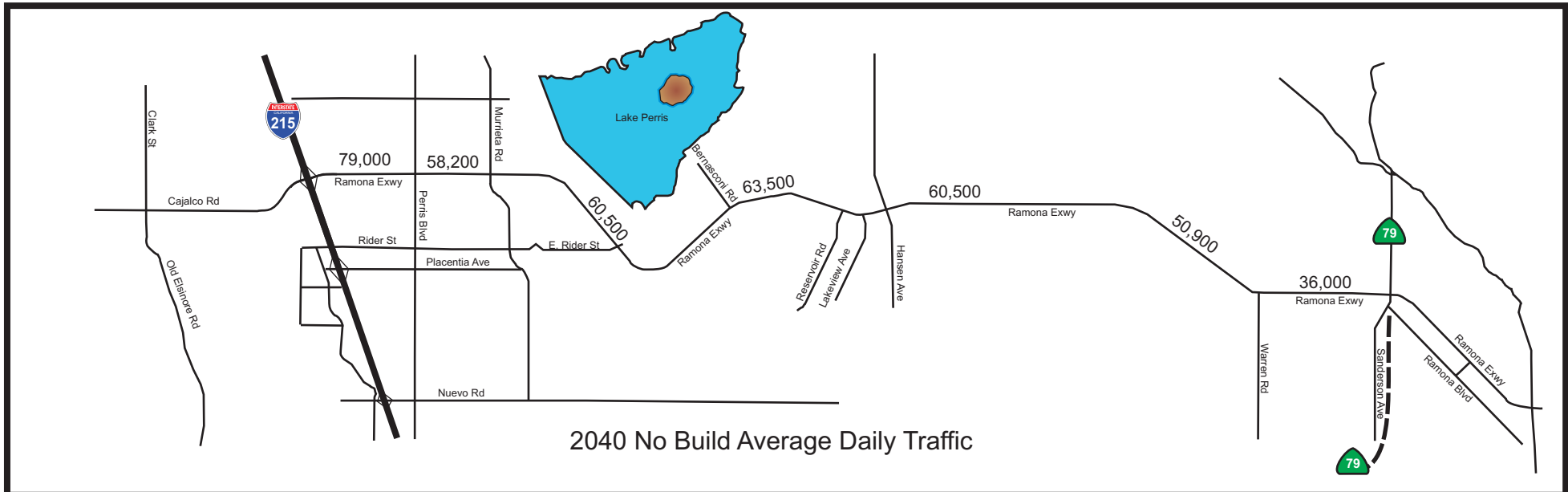

Horizon Year (2040) No Build Average Daily Traffic Compared to Build Average Daily Traffic Along Ramona Expressway and Mid County Parkway

Figure 10-2a

Legend:

- XX,XXX No Build: Average Daily Traffic
- XX,XXX Build Average Daily Traffic



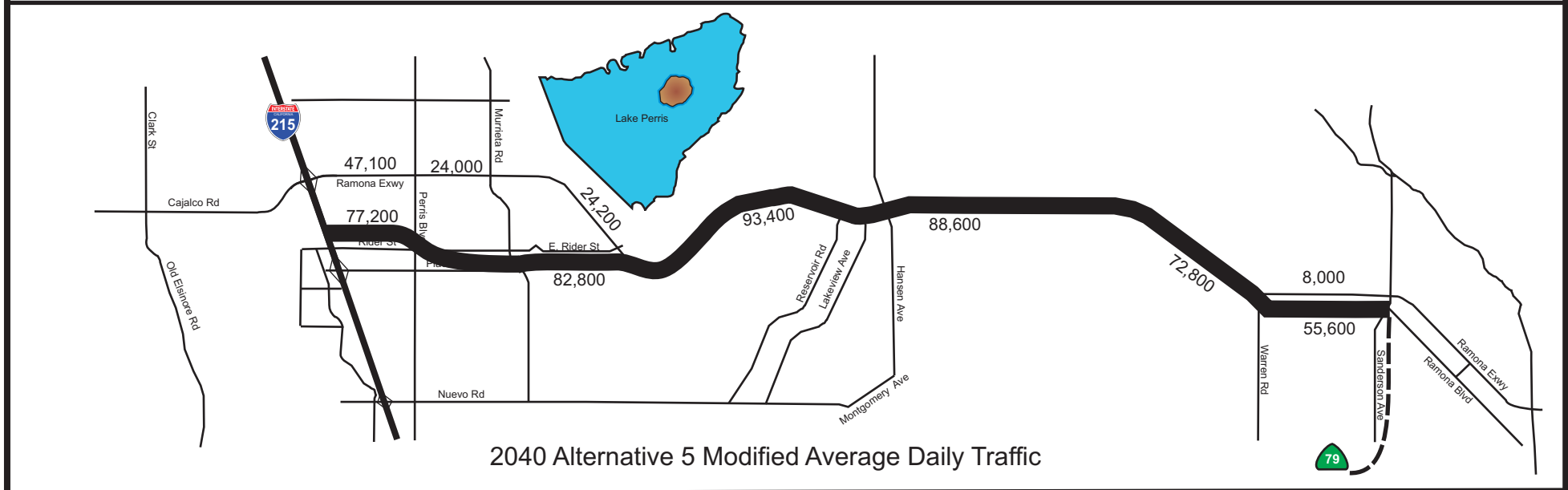
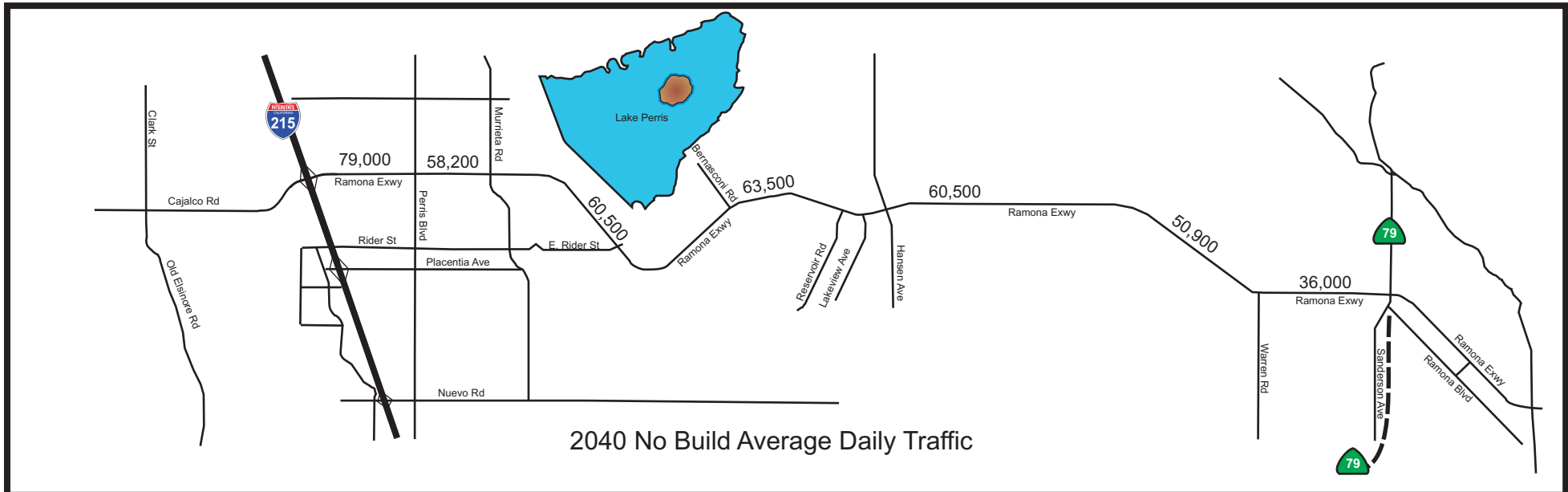

Horizon Year (2040) No Build Average Daily Traffic Compared to Build Average Daily Traffic Along Ramona Expressway and Mid County Parkway

Figure 10-2b

Legend:

- XX,XXX No Build: Average Daily Traffic
- XX,XXX Build Average Daily Traffic



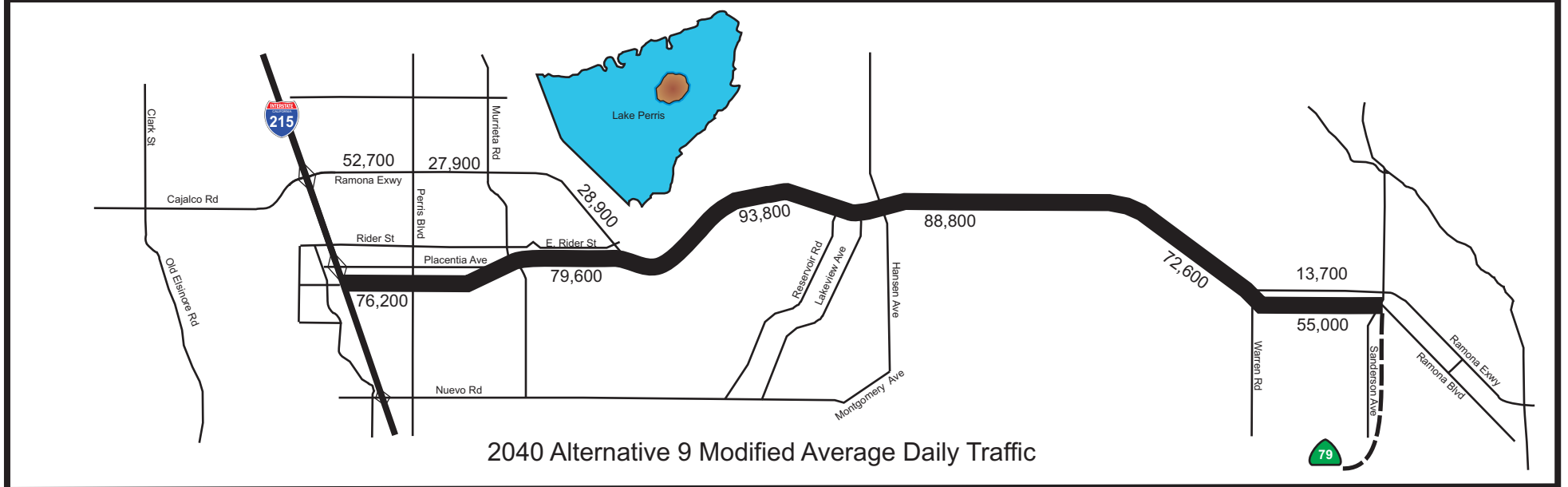
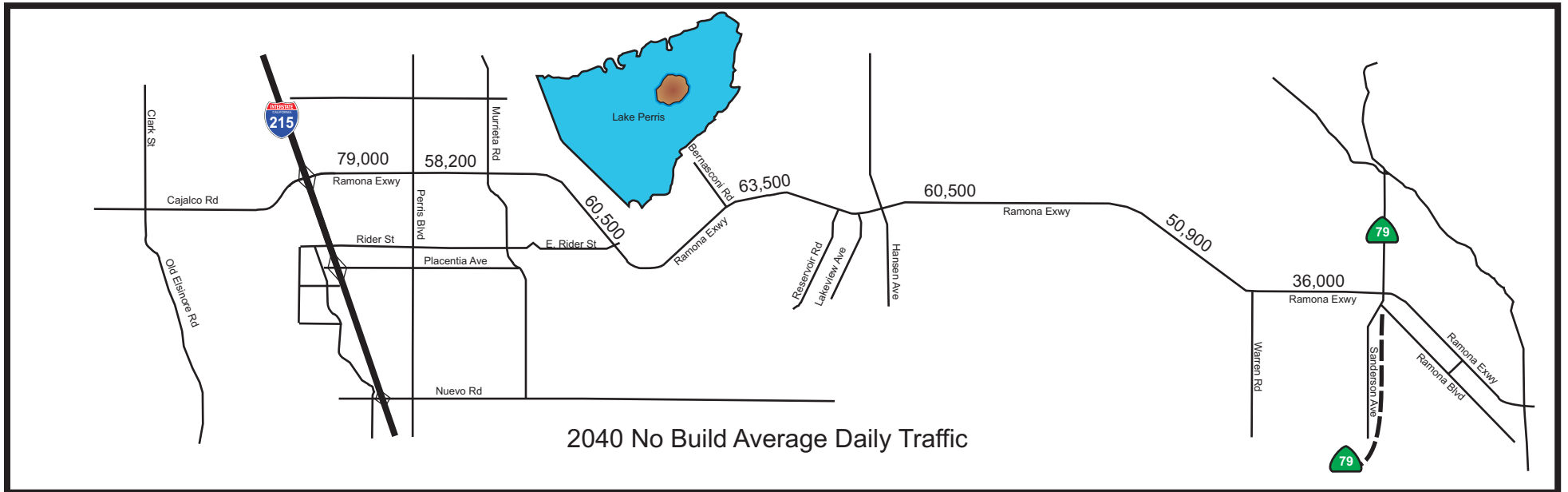

Horizon Year (2040) No Build Average Daily Traffic Compared to Build Average Daily Traffic Along Ramona Expressway and Mid County Parkway

Figure 10-2c

Legend:

- XX,XXX No Build: Average Daily Traffic
- XX,XXX Build Average Daily Traffic



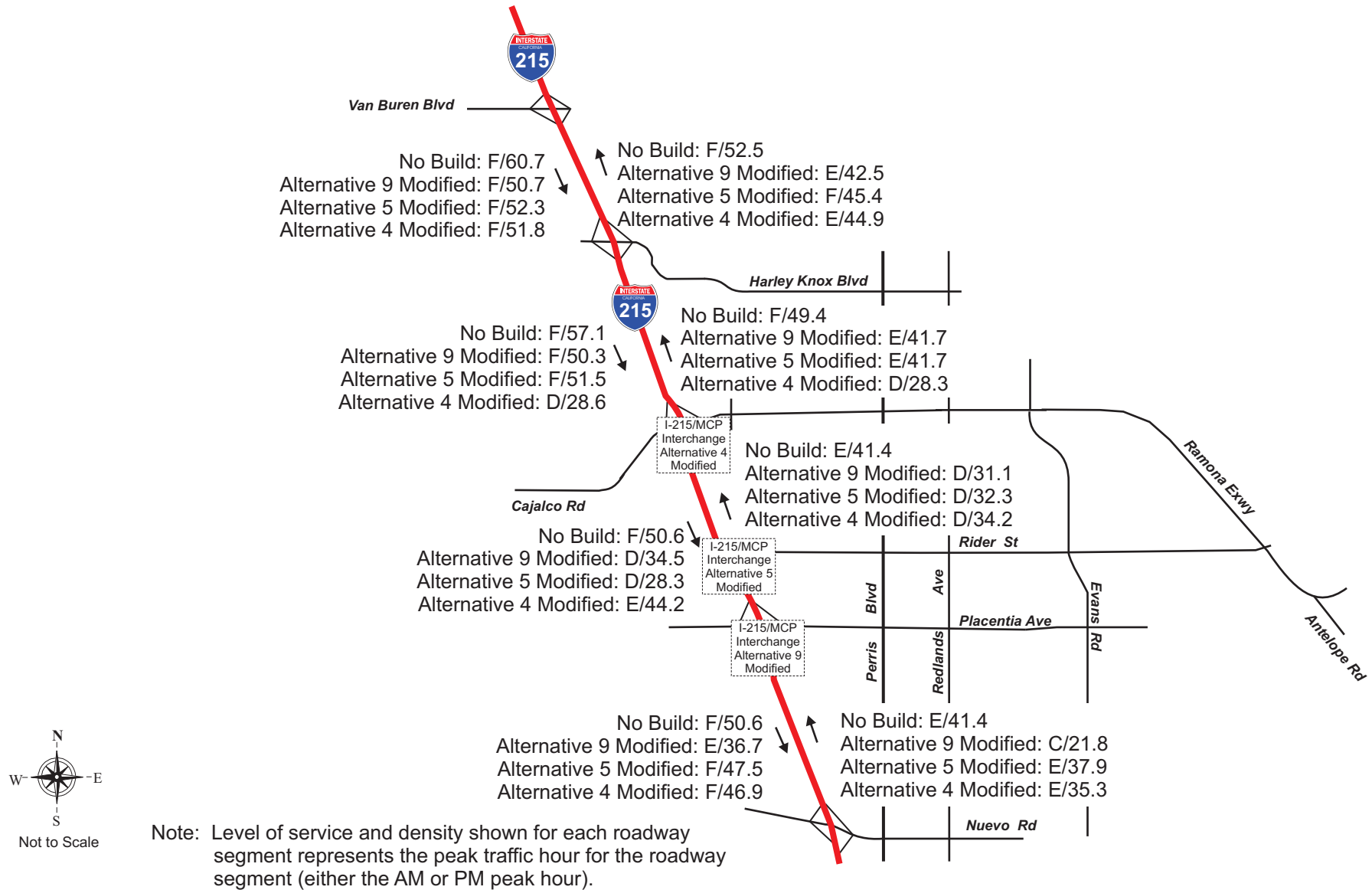

**Horizon Year (2040) I-215 Freeway Segment Operations
No Build Compared to Alternative 4, 5 and 9 Modified**

Figure 10-3

Legend:

- X/X No Build: Level of Service/Density (vehicles/mile/lane)
- X/X Alternative 9: Level of Service/Density (vehicles/mile/lane)



APPENDIX A

SCAG 2008 RTP Projects Within the MCP Study Area

SCAG 2008 RTP Projects Within MCP Study Area

Category	RTP ID	Route #	Route Name	From	To	Description	Completion Date
Arterial	3A04SH12A	79	SR-79	Domenigoni Pkwy (R15.6)	Gilman Springs Rd (M32.6)	Realignment/widening 4 to 6 lanes	2035
Auxiliary	3M0701	15	I-15	SR-79 South (3.44)	SR-79 North (6.62)	Add 1 auxiliary lane in both directions	2012
Auxiliary	3M0702	15	I-15	SR-60 (51.5)	San Bernardino County Line (52.8)	Also SBD-15-0.0/2.39 route 60 to I-10 add and extend aux lanes	2030
HOV	3M0703	5	I-5	I-215/I-15 JCT	SR-74	Build 2 HOV lanes (1 lane in each direction)	2020
Auxiliary	3M04SH11	60	SR-60	0.4 MI E/O I-15/SR-60 IC	0.2 MI E/O Main St	Add auxiliary lanes both directions	2009
IC/Ramps	3M01WT020	60	SR-60 (PM 2.53 to 3.53)	At Mission Blvd	Btwn Granite Hill Dr & Sevaine Way	Reconstruct interchange/ramps	2030
IC/Ramps	3M04MA11	91	SR91/I-15	SR91/I-15 Junction	SR91/I-15 Junction	Build connector improvements and collector distribution system at I-15	2020
IC/Ramps	3M0731	215	I-215 (PM 24.7 to 26.1)	At Ellis Ave	Btwn Perris Valley Storm Drain W/O I-215 to Dunlap Dr E/O I-215	Construct new 2 lane IC and ramps (1 lane)	2030
IC/Ramps	3M04WT009	215	I-215 (PM 23.04 to 24.04)	At SR-74 (Matthews Rd)	Btwn Case Rd & Trumble Rd	Reconstruct interchange/ramps	2030
IC/Ramps	3M04WT011	215	I-215 (PM 44.51 to 45.51)	At Center St	Between Stephens Ave and Iowa Ave	Reconstruct interchange/ramps	2030
Mixed Flow	3M04MA10	91	SR-91	Pierce Street	Orange County Line	Add 1 MF lanes each direction	2018
Toll	3HL0402	15	I-15	SR-74	San Bernardino County Line	Build HOV/HOT lanes: 2 HOV 3+/HOT each direction from SR-74 to San Bernardino County Line	2020
Toll	3HL0401	91	SR-91	Orange County Line	I-15	Build/extend 4 HOT lanes (2 in each direction) build HOT EB SR91 to SB I-15 and NB I-15 to WB SR91 connector lanes	2020
Truck Climbing	3TK04MA13	60	SR-60	Badlands Area east of Moreno Valley (near Gilman Springs Rd)	Badlands Area - west of SR-60/I-10 Jct	Add eastbound truck climbing lane	2018
HOV	3H07A	215	I-215	Nuevo Rd	Box Springs Rd	Add 1 HOV lane in each direction	2020
IC/Ramps	3A04A16	15	I-15	At Second St (Chaney Ave)	Camino Del Norte	Construct new 4 lane arterial segment connecting overcross over I-15	2035
IC/Ramps	3A04A17	15	I-15	At Riverside Dr	Between Collier Ave and Dexter Ave	Construct new 4 lane OC over I-15	2023
IC/Ramps	3A04A26	15	I-15	At Bellegrave Ave	Between Hamner Ave and Wineville Rd	Add signals and ramps	2030

IC/Ramps	3M04WT005	15	I-15 (PM 45.1 to 46.1)	At 6th St	Between Hamner Ave and Sierra Ave	Reconstruct interchange/ramps/channelization improvements	2018
IC/Ramps	3M04WT007	15	I-15 (PM 42.37 to 43.37)	At Hidden Valley Pkwy	Between Hamner Ave and beyond NB exit ramp	Reconstruct interchange/ramps/channelization improvements	2018
IC/Ramps	3M0728	15	I-15 (PM 32.60 to 33.60)	At Temescal Canyon	Near Indian Truck Trail and Glenn lvy just beyond and between ramps	Reconstruct/widen IC from 2 to 4 lanes and reconstruct ramps	2030
IC/Ramps	3M0729	15	I-15 (PM 28.36 to 29.36)	At Horsethief Canyon Rd	Just beyond and between ramps	Reconstruct/widen IC from 2 to 4 lanes and reconstruct ramps	2030
IC/Ramps	3M0733	15	I-15 (PM 43.13 to 44.13)	At 2nd St	Between Hamner Ave and Valley View Ave	Reconstruct/widen IC from 2 to 4 lanes and widen ramps	2018
IC/Ramps	3M0736	15	I-15 (PM 23.35 to 24.35)	At Nichols Rd	Between ramps	Reconstruct/widen IC from 2 to 6 lanes and reconstruct/widen ramps	2030
IC/Ramps	3M0737	15	I-15	At Lake St	Between Walker Canyon Rd and Temescal Canyon Rd	Reconstruct/widen IC from 2 to 6 lanes and reconstruct/widen ramps	2023
IC/Ramps	3A04A29	60	SR-60 (PM 9.06 to 10.06)	At Rubideaux Blvd	Between 30th and 34th St	Reconstruct/widen IC, ramps, and channelization improvements	2018
IC/Ramps	3A04A30	60	SR-60 (PM SBD 9.46 to 10.46)	At Milliken Ave	Between Harrel Ave and Iberia	Reconstruct/widen IC, ramps, and channelization improvements	2018
IC/Ramps	3M04WT017	60	SR-60 (PM 14.84 to 15.84)	At Heacock St	Between Hemlock Ave and Sunnymead Blvd	Widen/reconstruct IC, ramps, and channelization improvements; no additional lanes planned	2018
IC/Ramps	3M04WT018	60	SR-60 (PM 11.23 to 12.23)	At Main St	Between Russell St and Stoddard Ave	Reconstruct/widen IC and reconstruct/widen ramps, channelization improvements	2020
IC/Ramps	3M0712	60	SR-60 (PM 19.87 to 20.87)	At Redlands Blvd	Between Hemlock Ave and Fir Ave	Widen arterial from 2 to 6 lanes; ramp and aux lane improvements.	2020
IC/Ramps	3M0713	60	SR-60 (PM 15.85 to 16.85)	At Perris Blvd	Between Sunnymead Blvd and Ironwood	Reconstruct/widen arterial from 4 to 6 lanes and reconstruct/widen ramps (no additional lanes planned)	2018
IC/Ramps	3M0714	60	SR-60 (PM 21.60 to 22.60)	At Gilman Springs Rd	Between NB and SB on/off ramps	Widen and realign OC from 2 to 6 lanes; ramp and aux lane improvements	2020
IC/Ramps	3M0718	79	Sanderson Ave (SR-79) (PM 29.83 to 30.83)	At Ramona Expwy (SR-79)	Between N. Ramona Blvd and Ramona Expwy	Construct new 6 lane IC and ramps	2020

IC/Ramps	3M0723	79	SR-79 (Hemet Bypass)	At SR-74 (Florida Ave)	West of Hemet (between Warren Ave and 0.5 miles west of SR-79/SR-74 intersection)	Construct new 6 lane IC and ramps	2020
IC/Ramps	3M01WT021	91	SR-91 (PM 19.50 to 20.50)	At 14th St	Between Olivewood Ave and Commerce St	Reconstruct/widen IC and reconstruct/widen ramps	2018
IC/Ramps	3M01WT022	91	SR-91 (PM 15.50 to 15.70)	At Adams St	Between Diana Ave and Indiana Ave	Reconstruct/widen IC and reconstruct/widen ramps	2020
IC/Ramps	3M01WT023	91	SR-91 (PM 16.15 to 17.15)	At Madison St	Between Garden St and Indiana Ave	Reconstruct/widen IC and reconstruct/widen ramps	2020
IC/Ramps	3M01WT024	91	SR-91 (PM 10.6 to 11.6)	At Magnolia Ave	Between Merced Dr and Fillmore St	Reconstruct/widen IC and reconstruct/widen ramps	2020
IC/Ramps	3M01WT026	91	SR-91 (PM 12.9 to 13.1)	At Tyler St	Between Diana Ave and Indiana Ave	Reconstruct/widen IC and reconstruct/widen ramps	2020
IC/Ramps	3M01WT027	91	SR-91 (PM 20.02 to 20.53)	At University Ave/9th St	Between Lemon St and Vine St	Reconstruct/widen IC and reconstruct/widen ramps	2020
IC/Ramps	3M0709	91	SR-91 (PM 17.32 to 18.32)	At Arlington Ave	Between Mt Diablo to s/o EB entry ramps	Reconstruct/widen IC from 4 to 6 lanes and reconstruct/widen ramps	2018
IC/Ramps	3M0710	91	SR-91 (PM 18.36 to 19.36)	At Central Ave	Between Neva Pl and BNSF RR	Reconstruct/widen IC from 4 to 6 lanes and reconstruct/widen ramps	2018
IC/Ramps	3A04WT059	215	I-215 (PM 31.83 to 32.83)	At Oleander Ave	Between Harvill Ave and Western Way	Reconstruct/widen OC from 2 to 4 lanes and reconstruct/widen ramps	2018
IC/Ramps	3M04WT012	215	I-215 (PM 43.40 to 44.40)	At Columbia Ave	Between Primer St and Brandywine Ave	Reconstruct IC/ramps	2020
IC/Ramps	3M04WT014	215	I-215 (PM 27.38 to 28.38)	At Nuevo Rd	Between A St and E. Frontage Rd	Reconstruct IC, add channelization lanes on ramps, modify traffic signals	2018
IC/Ramps	3M04WT016	215	I-215/SR-60 (PM 40.99 to 41.99)	At University Ave	Between Iowa Ave and Canyon Crest Dr	Reconstruct IC/ramps	2020
IC/Ramps	3M0708	215	I-215 (PM 30.9)	At Ramona Expwy	Between ramps	Reconstruct/widen from 4 to 8 lanes; widen NB and SB exit ramps at I-215/Ramona Expwy IC and OC; construct dual left-turn lanes at the exit ramps termini	2018
IC/Ramps	3M0724	215	I-215 (PM 35.92 to 36.92)	At Alessandro Blvd	Between BNSF and Old 215 Frontage Rd	Widen/reconstruct IC from 4 to 6 lanes and reconstruct/widen ramps	2018
IC/Ramps	3M0725	215	I-215	At MCP	Between ramps	Construct new 6 lane IC and ramps	2020
Arterial	3A04A23		"A" Street	Nuevo Rd	4th St	Widen from 2 to 4 lanes	2012

Arterial	3A04WT0 92		11th St/Case Rd	Perris Blvd	Goetz Rd	Widen from 2 to 4 lanes	2007
Arterial	3A04WT0 86		1st St	Parkridge Ave	Hamner Ave	Widen from 2 to 4 lanes	2012
Arterial	3A04WT0 87		2nd St	River Rd	Hamner Ave	Widen from 2 to 4 lanes	2018
Arterial	3A07261		A St	San Jacinto St	4th St	Widen from 2 to 4 lanes	2030
Arterial	3A01WT0 49		Alessandro Blvd	I-215	Perris Blvd	Widen from 4 to 6 lanes	2012
Arterial	3A01WT0 50		Alessandro Blvd	Perris Blvd	Nason St	Widen from 2 to 6 lanes	2012
Arterial	3A01WT0 51		Alessandro Blvd	Nason St	Gilman Springs	Widen from 2 to 4 lanes	2012
Arterial	3A01WT1 23		Alessandro Blvd	Trautwein Rd	I-215	Widen from 4 to 6 lanes	2030
Arterial	3A01WT1 12		Arlington Ave	Magnolia Ave	Alessandro Blvd	Widen from 4 to 6 lanes	2018
Arterial	3A07047		At Graham St	Sunnymead Blvd	Hemlock Ave	Construct 4 lane OC over SR-60	2030
Arterial	3A01WT1 27		Bellevue Ave	Cantu-Galleano Ranch Rd	Van Buren Blvd	Widen from 2 to 4 lanes	2030
Arterial	3A04WT1 29		Briggs Rd	SR-74 (Pinacate Rd)	Simpson Rd	Construct 4 lane arterial	2030
Arterial	3A07144		Cactus Ave - St	Graham St	Heacock St	Widen from 4 to 6 lanes street improvement	2007
Arterial	3A04WT1 37		Cajalco Rd	Temescal Canyon Rd	Harley John Rd	Widen from 2 to 4 lanes	2030
Arterial	3A04WT1 38		Cajalco Rd	Harley John Rd	I-215	Widen from 2 to 6 lanes	2030
Arterial	3A04WT1 40		Cantu-Galleano Ranch Rd (Galena St)	Wineville Rd	Bellegrave Ave	Construct 4 lane arterial	2020
Arterial	3A07107		Canyon Crest Dr	Country Club	Century	Widen 2 to 4 lanes	2010
Arterial	3A07262		Case Rd	Goetz Rd	I-215	Widen from 2 to 4 lanes	2030
Arterial	3A07287		Cawston Ave	Esplanade Ave	Ramona Expwy	Construct 4 lanes	2030
Arterial	3A01WT1 14		Central Ave	Magnolia Ave	SR-91	Widen from 4 to 6 lanes between SR-91 and Magnolia	2018
Arterial	3A04WT1 47		Cloverdale Rd	Archibald Ave	Hamner Ave	Widen from 2 to 4 lanes	2030
Arterial	3A04WT0 88		Corydon Ave	River Rd	Norco Dr	Widen from 2 to 4 lanes	2030
Arterial	3A07288		Cottonwood Ave	Warren Rd	State St	Widen from 2 to 4 lanes	2030
Arterial	3A07263		D St	San Jacinto St	4th St	Widen from 2 to 4 lanes	2030
Arterial	3A07264		Dunlap	Orange	Ellis Ave	Widen from 2 to 4 lanes	2030
Arterial	3A04WT0 49		El Cerrito Rd	I-15	Ontario Ave	Widen from 2 to 4 lanes	2030
Arterial	3A04WT0 93		Ellis Ave	SR-74	I-215	Construct 2 lane arterial and 2 lane grade separation over BNSF RR (keep grade separation in arterial section)	2010
Arterial	3A04WT1 50		Ellis Ave	Post Rd	SR-74	Widen from 2 to 4 lanes	2030

Arterial	3A04WT2 08		Esplanade Ave	Warren Rd	State St	Widen from 2 to 4 lanes	2009
Arterial	3A01WT1 51		Ethanac Rd	SR-74	Keystone Dr	Construct 4 lane arterial	2030
Arterial	3A01WT1 52		Ethanac Rd	Sherman Rd	Matthews Rd	Widen from 2 to 4 lanes incl. Grade separation over BNSF RR	2030
Arterial	3A04WT0 52		Eucalyptus Ave	I-215	Towngate Blvd	Widen from 4 to 6 lanes	2014
Arterial	3A07162		Eucalyptus Ave	Towngate Blvd	Elsworth St	Street improvement/widening	2014
Arterial	3A01WT1 00		Evans Rd	Nuevo Rd	I-215	Construct 4 lane arterial	2010
Arterial	3A04WT0 99		Evans Rd	Placentia Ave	Nuevo Rd	Construct 4 lane arterial	2010
Arterial	3A01WT0 53		Gilman Springs Rd	SR-60	Alessandro Blvd	Widen from 2 to 6 lanes	2012
Arterial	3A01WT1 53		Gilman Springs Rd	Alessandro Blvd	Bridge St	Widen from 2 to 6 lanes	2012
Arterial	3A01WT1 54		Gilman Springs Rd	Bridge St	Sanderson Ave	Widen from 2 to 4 lanes	2030
Arterial	3A01WT1 01		Goetz Rd	Case Rd	Ethanac Rd	Widen from 2 to 4 lanes	2010
Arterial	3A04WT1 02		Goetz Rd	Lesser Ln	Ethanac Rd	Widen from 2 to 4 lanes	2010
Arterial	3A04WT0 89		Hamner	Cota St	Hamner Ave	Widen from 4 to 6 lanes	2018
Arterial	3A01WT1 58		Hamner Ave	Mission Blvd	Bellegrave Ave	Widen from 2 to 6 lanes	2030
Arterial	3A01WT1 59		Hamner Ave	Bellegrave Ave	Santa Ana River	Widen from 2 to 6 lanes	2030
Arterial	3A04WT1 60		Harley John Rd	Washington St	Cajalco Rd	Widen from 2 to 4 lanes	2030
Arterial	3A07160		Heacock St - SI	Eucalyptus	Fir	Street improvement/widening	2020
Arterial	3A07168		Heacock St - SI	Dracaea	Eucalyptus	Street improvement/widening	2020
Arterial	3A07169		Heacock St - SI	Ironwood Ave	Manzanita Ave	Street improvement/widening	2020
Arterial	3A07289		Hewitt St	Main St	South City Limit	Widen from 2 to 4 lanes	2030
Arterial	3A04WT0 90		Hillside Ave	1st St	Hidden Valley Pkwy	Construct 2 lane arterial	2030
Arterial	3A04WT1 61		Horsethief Canyon Rd	Temescal Canyon Rd	I-15	Widen from 2 to 4 lanes	2030
Arterial	3A07265		Indian Ave	North City Limit	Orange	Widen from 2 to 4 lanes	2030
Arterial	3A04WT0 55		Indian St	San Michele Rd	Oleander Ave	Widen from 2 to 4 lanes	2020
Arterial	3A07045		Indian St	Hemlock St	Sunnymead Blvd	Widen OC from 2 to 4 lanes	2030
Arterial	3A04WT1 62		Indian Truck Trail	Temescal Canyon Rd	I-15	Widen from 2 to 4 lanes	2030
Arterial	3A07290		Kirby St	Esplanade Ave	Cottonwood Ave	Widen from 2 to 4 lanes	2030
Arterial	3A04WT0 43		Lake St	I-15	Lincoln St	Widen from 2 to 6 lanes	2018

Arterial	3A01WT0 57		Lasselle St	Eucalyptus	John F Kennedy	Widen from 2 to 4 lanes	2012
Arterial	3A01WT1 63		Limonite Ave	Etiwanda Ave	Van Buren Blvd	Widen from 2 to 4 lanes	2012
Arterial	3A01WT1 64		Limonite Ave	Van Buren Blvd	Clay St	Widen from 4 to 6 lanes	2030
Arterial	3A07016		Limonite Ave	Hammer Ave	Etiwanda Ave	Widen from 2 to 4 lanes	2020
Arterial	3A04T027		Magnolia Ave	Ontario Ave	Rimpau Ave	Intersection upgrades on Magnolia Ave between Ontario and Rimpau to accommodate restriping from 4 to 6 lanes	2035
Arterial	3A04T029		Main St	SR-91	North Grand Blvd	Widen from 4 to 6 lanes	2010
Arterial	3A04WT0 30		Main St	South Grand Blvd	Ontario Ave	Widen from 2 to 4 lanes	2018
Arterial	3A07266		Mapes Ave	Goetz Rd	West City Limit	Construct 4 lanes	2030
Arterial	3A07268		Markham St	Wade	Redlands Ave	Widen from 2 to 4 lanes	2030
Arterial	3A07267		McPherson Rd	Ethanac Rd	Mapes Ave	Construct 4 lanes	2030
Arterial	3A01WT1 71		Menifee Rd	SR-74 (Pinacate Rd)	Simpson Rd	Widen from 2 to 4 lanes incl. Grade separation over RR	2030
Arterial	3A07044		MCP	Arantine Hills/Eagle	I-15	Construct new 4 lane arterial segment	2012
Arterial	3A07003		MCP	I-15	I-215	Construct 4 lane arterial (I-15 to Harley John). Construct 2 lane arterial (Harley John to I-215).	2030
Arterial	3A07013		MCP	Rider St	Warren Rd	Construct 2 lane arterial	2030
Arterial	3A01WT1 10A		MCP	I-215	Rider St	Widen from 2 to 6 lanes	2018
Arterial	3A07105		Moreno Beach Dr	Reche Canyon Rd	SR-60	Widen from 2 to 4 lanes	2020
Arterial	3A07155		Moreno Beach Dr	Cactus Ave	Automall Dr	Widen 2 to 6 lanes/street improvement	2012
Arterial	3A07269		Morgan St	Nevada	Indian Ave	Widen from 2 to 4 lanes	2030
Arterial	3A07270		Morgan St	Indian Ave	Bradley Rd	Construct 4 lanes	2030
Arterial	3A07271		Mountain Ave	McPherson	A St	Widen from 2 to 4 lanes	2030
Arterial	3A04WT1 75		Murrieta Rd	Ethanac Rd	McCall Blvd	Widen from 2 to 4 lanes	2030
Arterial	3A07272		Murrieta Rd	Case Rd	Ethanac Rd	Widen from 2 to 4 lanes	2030
Arterial	3A04WT0 70		Nason St	Ironwood Ave	Alessandro Blvd	Widen from 2 to 4 lanes	2010
Arterial	3A07101		Nason St	Iris Ave	Delphinium Ave	Construct 4 lanes	2018
Arterial	3A07119		Nason St	Cactus Ave	Alessandro Blvd	Widen 4 to 6 lanes/street improvement	2010
Arterial	3A07135		Nason St	Delphinium Ave	Cactus Ave	Construct 6 lanes	2010
Arterial	3A04A11		Nichols Rd	Collier Ave	Dexter Ave	Widen from 2 to 6 lanes	2023
Arterial	3A04WT0 91		Norco Dr	Corydon Ave	Hammer Ave	Widen from 2 to 4 lanes	2012
Arterial	3A04WT1 79		Nuevo Rd	Dunlap Dr	Menifee Rd	Widen from 2 to 4 lanes	2030
Arterial	3A04WT0 60		Oleander Ave	Western Way	Indian Ave	Widen from 2 to 4 lanes	2010
Arterial	3A07273		Orange Ave	Indian Ave	Dunlap Dr	Widen from 2 to 4 lanes	2030
Arterial	3A04WT1 17		Overlook Pkwy	Chateau Ridge Ln	Sandtrack Rd	Construct new 4 lane arterial	2010
Arterial	3A07291		Palm Ave	Esplanade Ave	Seventh St	Construct 4 lanes	2030
Arterial	3A07292		Palm Ave	Seventh St	Ramona Blvd	Widen from 2 to 4 lanes	2030

Arterial	3A01WT0 61		Perris Blvd	Cactus Ave	Oleander Ave	Widen from 2 to 6 lanes	2010
Arterial	3A01WT1 05		Perris Blvd	Ramona Expwy	Nuevo Rd	Widen from 4 to 6 lanes	2012
Arterial	3A01WT1 06		Perris Blvd	Nuevo Rd	11th St	Widen from 2 to 4 lanes	2018
Arterial	3A07140		Perris Blvd	Ironwood Ave	Sunnymead Blvd	Widen from 4 to 6 lanes	2020
Arterial	3A07170		Perris Blvd	Dracaea	Fir	Widen from 4 to 6 lanes/street improvement	2020
Arterial	3A01WT1 07		Placentia Ave	Indian Ave	Evans Rd	Widen from 2 to 4 lanes	2012
Arterial	3A04WT0 32		Railroad St	Sherman Ave	Main St (at Grand)	Widen from 2 to 4 lanes	2010
Arterial	3A07293		Ramona Blvd	Seventh St	San Jacinto Ave	Widen from 2 to 4 lanes	2030
Arterial	3A01WT1 08		Ramona Expwy	I-215 East Ramps	Perris Blvd	Widen from 4 to 6 lanes	2018
Arterial	3A01WT1 09		Ramona Expwy	Perris Blvd	Evans Rd	Widen from 4 to 6 lanes	2018
Arterial	3A01WT1 10B		Ramona Expwy	Evans Rd	Rider St	Widen from 2 to 6 lanes	2018
Arterial	3A01WT1 82		Ramona Expwy	Rider St	Pico Ave	Widen from 4 to 6 lanes	2030
Arterial	3A01WT1 83		Ramona Expwy	Pico Ave	Bridge St	Widen from 2 to 6 lanes	2030
Arterial	3A01WT2 06		Ramona Expwy	Bridge St	Warren Rd	Widen from 2 to 6 lanes	2030
Arterial	3A01WT2 10		Ramona Expwy	Sanderson Ave	State St	Widen from 2 to 6 lanes	2009
Arterial	3A07274		Redlands Blvd	Oleander Ave	Placentia Ave	Construct 4 lanes	2030
Arterial	3A07275		Redlands Blvd	Placentia Ave	Ellis Ave	Widen from 2 to 4 lanes	2030
Arterial	3A01WT0 67		Redlands Blvd	Locust Ave	Alessandro Blvd	Widen from 2 to 4 lanes	2014
Arterial	3A07156		Redlands Blvd	Cactus Ave	SR-60	Widen 2 to 4 lanes/street improvement	2012
Arterial	3A07276		Rider St	Nevada	Ramona Expwy	Widen 2 to 4 lanes	2030
Arterial	3A04A35		Riverside Dr	Hamner Ave	Etiwanda Ave	Widen 2 to 4 lanes	2030
Arterial	3A04A36		Riverside Dr at Day Creek	Wineville Rd	Etiwanda Ave	Widen 2 to 4 lanes	2030
Arterial	3A07277		San Jacinto Ave	West City Limit	Navajo	Widen from 2 to 6 lanes	2030
Arterial	3A07278		San Jacinto Ave	Navajo	A St	Construct 4 lanes	2030
Arterial	3A07279		San Jacinto Ave	A St	Redlands Ave	Widen from 2 to 4 lanes	2030
Arterial	3A07280		San Jacinto Ave	Redlands Ave	Dunlap Dr	Widen from 2 to 6 lanes	2030
Arterial	3A04WT0 68		San Michele Rd	Heacock St	Indian Ave	Widen from 2 to 4 lanes	2010
Arterial	3A01WT1 85		Sanderson Ave (SR-79)	Gilman Springs Rd (at SR-79)	Ramona Expwy	Widen from 4 to 6 lanes	2030
Arterial	3A04WT1 87		Schleisman Rd	Harrison Ave	Cleveland Ave	Construct 4 lane arterial	2030
Arterial	3A04WT1 88		Schleisman Rd	Cleveland Ave	68th St	Widen from 2 to 4 lanes	2030

Arterial	3A04WT1 89	Schleisman Rd	68th St	I-15	Construct 6 lane arterial	2018
Arterial	3A07014	Schleisman Rd	I-15	Arlington Ave	Construct 4 lane arterial	2030
Arterial	3A07294	Seventh St	Warren Rd	Cawston Ave	Construct 4 lanes	2030
Arterial	3A07295	Seventh St	Cawston Ave	Ramona Expwy	Widen from 2 to 4 lanes	2030
Arterial	3A04WT0 37	SR-74	Winchester Rd (SR-79)	Warren Rd	Widen from 4 to 6 lanes	2009
Arterial	3A04WT1 91	SR-74	I-15	Ethanac Rd	Widen from 4 to 6 lanes	2020
Arterial	3A07260	SR-74	Navajo	I-215	Widen from 2 to 4 lanes	2030
Arterial	3A04WT1 90	SR-74 (Ethanac)	Matthews Rd	SR-79 (Winchester)	Widen from 2 to 4 lanes (Matthews to Briggs). Widen from 4 to 6 lanes (Briggs to SR-79)	2020
Arterial	3A04WT0 47	SR-74 (Riverside Dr/Collier Ave)	I-15	Lakeshore Dr	Widen from 2 to 6 lanes	2010
Arterial	3A01WT2 13	SR-79	North Ramona Blvd	7th St	Widen from 2 to 4 lanes	2018
Arterial	3A01WT1 96	SR-79 (Eastern Bypass)	SR-79 (Winchester Rd near Scott Rd)	I-15	Construct 4 lane arterial	2020
Arterial	3A01WT1 92	SR-79 (Gilman Springs)	Sanderson Ave	State St	Widen from 2 to 4 lanes	2030
Arterial	3A01WT0 39	State St	Johnston Ave	Florida Ave (SR-74)	Widen from 2 to 4 lanes	2008
Arterial	3A01WT2 14	State St	Gilman Springs Rd	Quandt Ranch Rd	Widen from 2 to 4 lanes	2018
Arterial	3A04WT1 97	Temescal Canyon Rd	Ontario Ave	Indian Truck Trail	Widen from 2 to 4 lanes	2030
Arterial	3A04WT1 98	Temescal Canyon Rd	Indian Truck Trail	Lake St	Widen from 2 to 4 lanes	2030
Arterial	3A07281	Trumble Rd	Mapes Ave	Ellis Ave	Widen from 2 to 4 lanes	2030
Arterial	3A04WT1 18	Tyler St	Wells Ave	Arlington Ave	Widen from 2 to 4 lanes	2020
Arterial	3A04WT2 24	Valley Way	Armstrong Rd	Mission Blvd	Widen from 2 to 4 lanes	2018
Arterial	3A01WT1 99	Van Buren Blvd	Mockingbird Canyon Rd	Wood Rd	Widen from 4 to 6 lanes	2018
Arterial	3A01WT2 01	Van Buren Blvd	SR-60	Santa Ana River	Widen from 4 to 6 lanes	2030
Arterial	3A07007	Van Buren Blvd	Orange Terrace Pkwy	I-215	Widen from 4 to 6 lanes	2030
Arterial	3A07315	Van Buren Blvd	Jackson St	Garfield	Widen from 4 to 6 lanes	2014
Arterial	3A01WT0 41	Warren Rd	Esplanade Ave	Domenigoni Pkwy	Widen from 2 to 4 lanes	2030
Arterial	3A01WT2 15	Warren Rd	Ramona Expwy	Esplanade Ave	Widen from 2 to 4 lanes	2012
Arterial	3A04WT1 20	Washington St	Victoria Ave	Hermosa Dr	Widen from 2 to 4 lanes	2018
Arterial	3A04WT2 02	Washington St	Hermosa Dr	Harley John Rd	Widen from 2 to 4 lanes	2030

Arterial	3A07282		Watson	A St	McPherson Rd	Construct 4 lanes	2030
Arterial	3A07283		Webster Ave	Oleander Ave	Markham	Construct 6 lanes	2030
Arterial	3A07284		Webster Ave	Markham	Ramona Expwy	Widen from 2 to 6 lanes	2030
Arterial	3A07285		Webster Ave	Ramona Expwy	Rider St	Widen from 2 to 4 lanes	2030
Arterial	3A04WT1 21		Wood Rd	John F Kennedy Dr	Van Buren	Widen from 2 to 4 lanes	2012
Arterial	3A04WT2 03		Wood Rd	Krameria Ave	Cajalco Rd	Widen from 2 to 4 lanes	2030

APPENDIX D

Mid County Parkway Travel Time Analysis

MEMORANDUM

TO: Cathy Bechtel, Riverside County Transportation Commission
FROM: Erik Ruehr, VRPA Technologies
DATE: October 11, 2011
RE: Mid County Parkway
Travel Time Analysis

This memorandum provides an analysis of travel time along the Mid County Parkway (MCP) corridor for various alternatives of future roadway development. The alternatives correspond to the alternatives currently under study for the MCP project.

Following are estimates for the Year 2040 of the time required to travel between State Route 79 (SR 79) to Interstate 215 (I-215) along the Mid County Parkway corridor for various Mid County Parkway alternatives:

- ◆ No Build/County General Plan: 44.3 minutes
- ◆ Alternative 4 Modified: 15.9 minutes
- ◆ Alternative 5 Modified: 14.8 minutes
- ◆ Alternative 9 Modified: 14.2 minutes

These travel time estimates were prepared using the following assumptions:

- ◆ Average speed on the Mid County Parkway was assumed to be 61.5 mph, corresponding to level of service D conditions and a 70 mph free flow speed.
- ◆ For No Build/County General Plan conditions, an average travel speed of 21 mph was assumed. This speed was based on level of service D conditions for an arterial street (Class I), using the Urban Streets methodology of the 2000 Highway Capacity Manual. The assumption is that Riverside County (and cities along the corridor) will provide necessary widening to achieve level of service D operating conditions in order to meet the goals of their Circulation Elements.

If you have any questions, I can be reached by email at eruehr@vrpatechnologies.com or by phone at 858/566-1766.